

Manual

EN

Appendix

Transfer Switch

Copyrights © 2008 Victron Energy B.V.
All Rights Reserved

This publication or parts thereof may not be reproduced in any form, by any method, for any purpose.

For conditions of use and permission to use this manual for publication in other than the English language, contact Victron Energy B.V.

VICTRON ENERGY B.V. MAKES NO WARRANTY, EITHER EXPRESSED OR IMPLIED, INCLUDING BUT NOT LIMITED TO ANY IMPLIED WARRANTIES OF MERCHANTABILITY OR FITNESS FOR A PARTICULAR PURPOSE, REGARDING THESE VICTRON ENERGY PRODUCTS AND MAKES SUCH VICTRON ENERGY PRODUCTS AVAILABLE SOLELY ON AN "AS IS" BASIS.

IN NO EVENT SHALL VICTRON ENERGY B.V. BE LIABLE TO ANYONE FOR SPECIAL, COLLATERAL, INCIDENTAL, OR CONSEQUENTIAL DAMAGES IN CONNECTION WITH OR ARISING OUT OF PURCHASE OR USE OF THESE VICTRON ENERGY PRODUCTS. THE SOLE AND EXCLUSIVE LIABILITY TO VICTRON ENERGY B.V., REGARDLESS OF THE FORM OF ACTION, SHALL NOT EXCEED THE PURCHASE PRICE OF THE VICTRON ENERGY PRODUCTS DESCRIBED HERE IN.

Victron Energy B.V. reserves the right to revise and improve its products as it sees fit. This publication describes the state of this product at the time of its publication and may not reflect the product at all times in the future.

1. Introduction

The TRANSFER SWITCH is designed to take over automatic switching between different power sources: between a generator and the shore, or between an inverter and a generator, or between an inverter and the shore. The TRANSFER SWITCH has two inputs and one output and automatically transfers the available AC power to output. It can be used with any Victron Energy inverter, depending on the capacity.

Operation

The TRANSFER SWITCH is situated between a generator or shore and inverter. If the voltage level or the frequency of the generator or the shore varies (input 1), then the TRANSFER SWITCH switches to the inverter (input 2). Once the generator or the shore supply has remained continuously stable, the TRANSFER SWITCH switches back (input 1) with a delay of approximately 10 seconds. This way, the appliances are protected against damage from voltage drops. During transfer between one of the power sources (input 1 or input 2), the appliances are not supplied with power for a short time. Because of this, computers, electronic devices etc. connected to this group might lose data. The TRANSFER SWITCH can be used with any type of inverter but the best results, however, are obtained with an inverter from Victron Energy.

1.1 Installation

- **WARNING!** Be sure that all AC power sources are switched off or disconnected during installation.
- Install the TRANSFER SWITCH in a dry, well ventilated area. The front of the casing is attached using the four supplied screws. The TRANSFER SWITCH may be mounted on the wall, using the four holes in the rear of the casing.
- The input cables from the mains/generator and the inverter, and output cables to the appliances should be connected according to the wiring diagram (see figure 1). Use the provided cable-glands to pass the cables through the casing. The correct wire cross section must be applied for a safe installation. Under sized cables can cause overheating of the cables.
- Tighten all connections well in order to limit transition resistance as far as possible. Loose connections can cause dangerous overheating of the terminals.
- Adjustment of the TRANSFER SWITCH is not recommended. After correct installation the TRANSFER SWITCH is ready for use. However specific circumstances may require adjustment of the switch on delay time of input 1. Use a small flat blade screw driver to adjust the delay time.
- The wiring to the AC-inputs and outputs must be protected by fuses or miniature circuit breakers which are suitable for the applied wire cross section. External earth leakage switches(RCD, RCCB) must also be integrated in the wiring
- All ground connections of the power sources and power consumers must be connected to the central ground connection of the ship.
- Auxiliary contact 1 and 2 of relay K2 (NO) must be connected with a screw connector on the back of Digital Multi Control panel (DMC) when an external transfer switch is used with VE MultiPlus and DMC (picture on page 7). When the auxiliary contact is open the current limit is controlled by the knob on the front of the DMC. When the auxiliary contact is closed the DMC sends the present generator current to connected devices. The auxiliary contact is normally controlled by the TRANSFER SWITCH.

2. Specifications

VE TRANSFER SWITCH	COS 0 - 5kVA	COS 0 - 10kVA
Nominal voltage	200 - 250V AC, Single phase	
Nominal frequency	50 – 60 Hz	
Input 1, Nom. current	20 A	40 A
Input 2, Nom. current	20 A	40 A
Output, Nom. current	20 A	40 A
Max. motor (airco) power	1,3 kW	8 kW
Power consumption Input 1	6 VA	6 VA
Power consumption Input 2	0 VA	0 VA
Transfer time by closing contacts	10 – 20 msec.	10 – 20 msec.
Transfer time by opening contacts	5 – 20 msec.	5 – 20 msec.
Transfer time by closing contacts	10 – 20 msec.	10 – 20 msec.
Contacts delay Input 1	Approximately 10 sec. (adjustable)	
Auxiliary contact	200 - 240V AC; 20 A, cos φ =1	
GENERAL		
Operating temperature	-5°C to + 60°C	
Humidity (non-condensing)	Max. 95%	
Miniature circuit breaker (MCB)	Not included – installation dependent	
Earth leakage breakers (RCD)	Not included – installation dependent	
ENCLOSURE		
Protection category	IP 54	
Colour	RAL 7035	
Dimension h x w x d (mm)	175 x 215 x 120	175 x 215 x120
Weight (kg)		



APPENDIX A: Electrical & installation diagrams, outline drawings COS 0 - 5kVA

**INPUT 1
(Generator)**

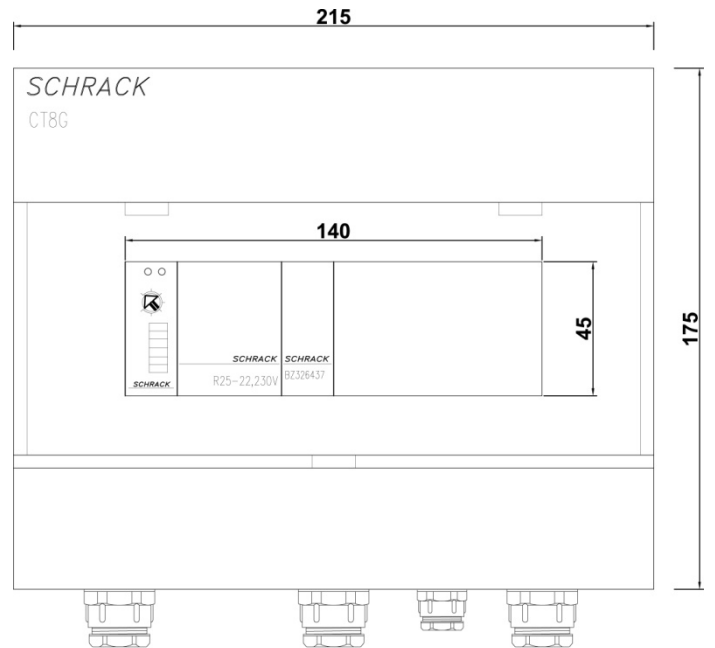
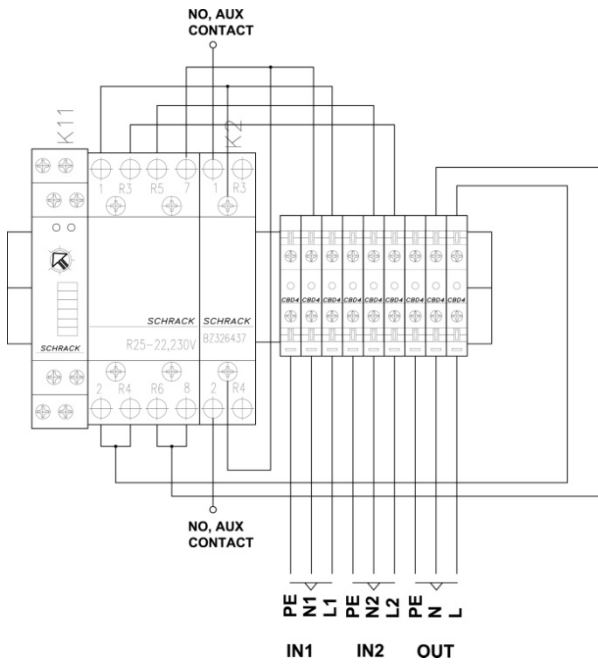
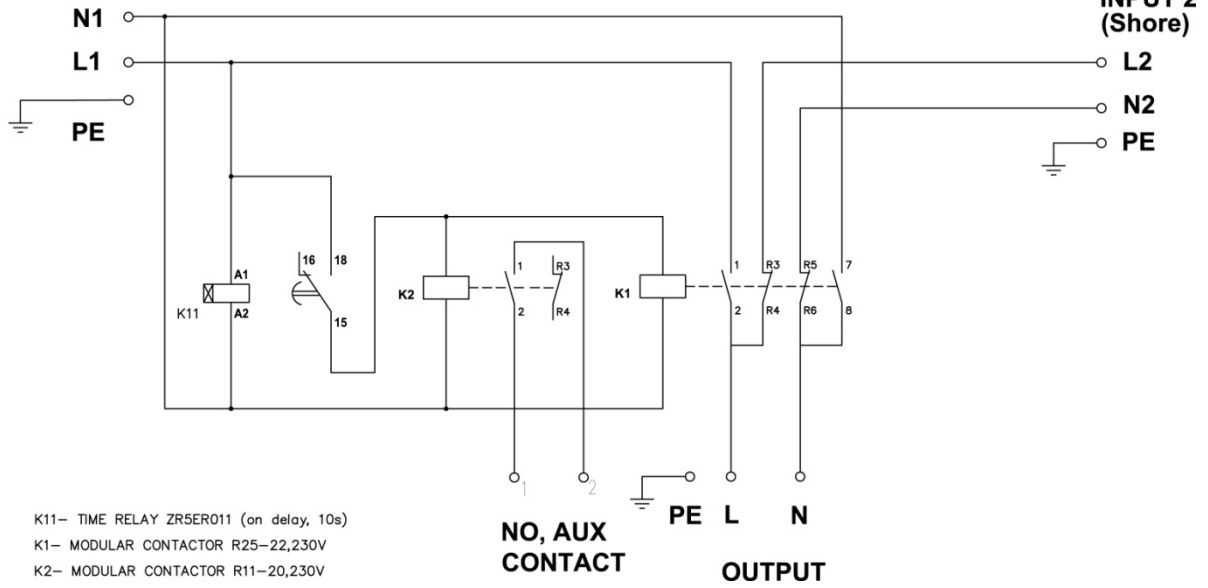

All dimensions are in mm!

Appendix B: Electrical & installation diagrams - COS 0 - 10kVA

**INPUT 1
(Generator)**

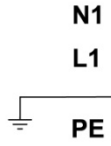

**INPUT 2
(Shore)**

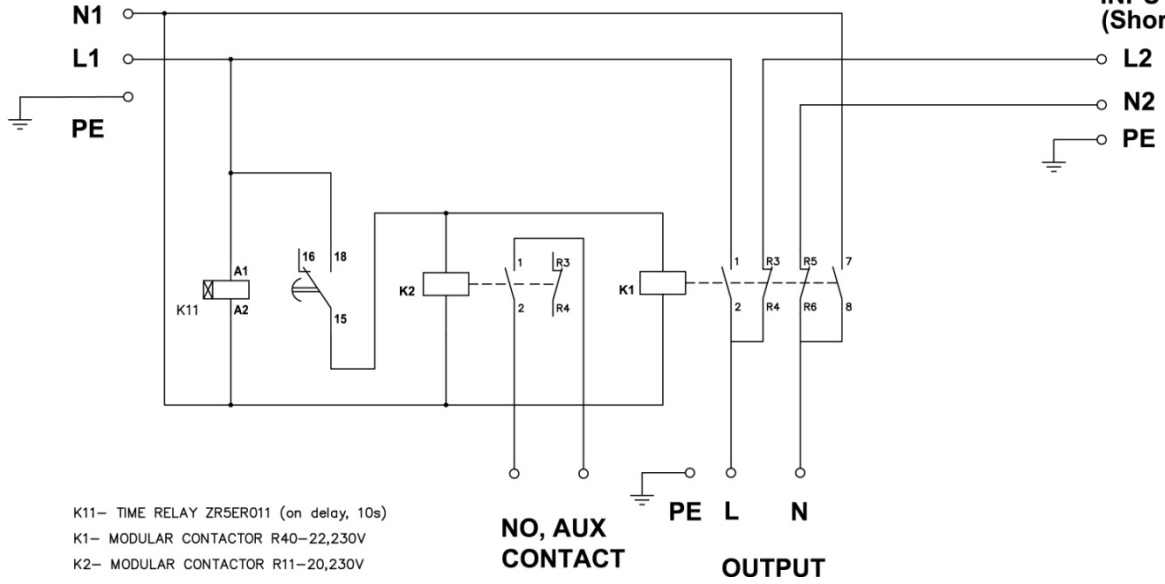
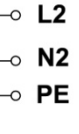

- K11- TIME RELAY ZR5ER011 (on delay, 10s)
- K1- MODULAR CONTACTOR R40-22,230V
- K2- MODULAR CONTACTOR R11-20,230V

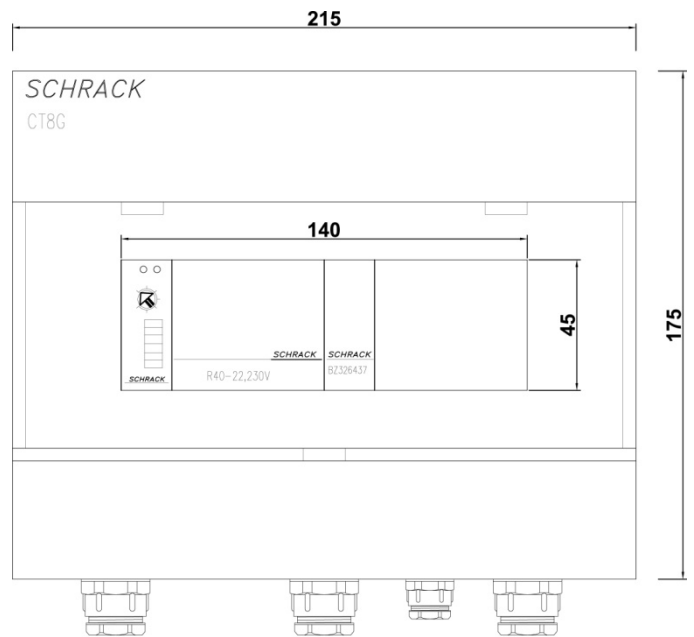
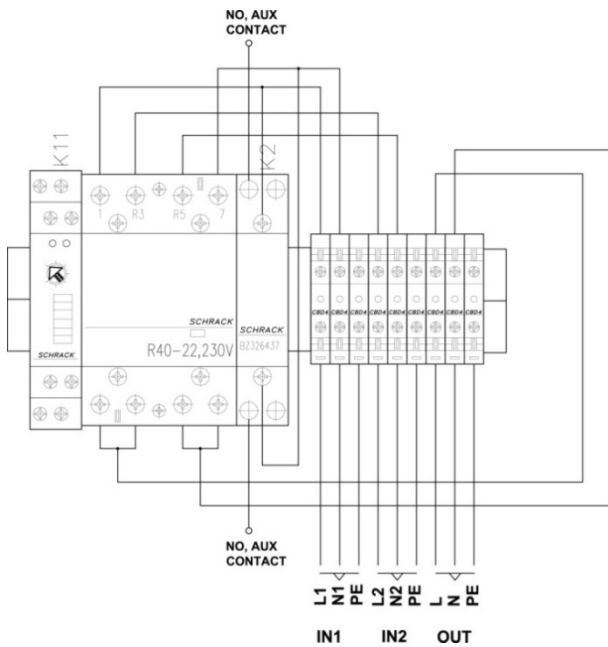

All dimensions are in mm!

Appendix E: wiring with Digital Multi Control panel (DMC)

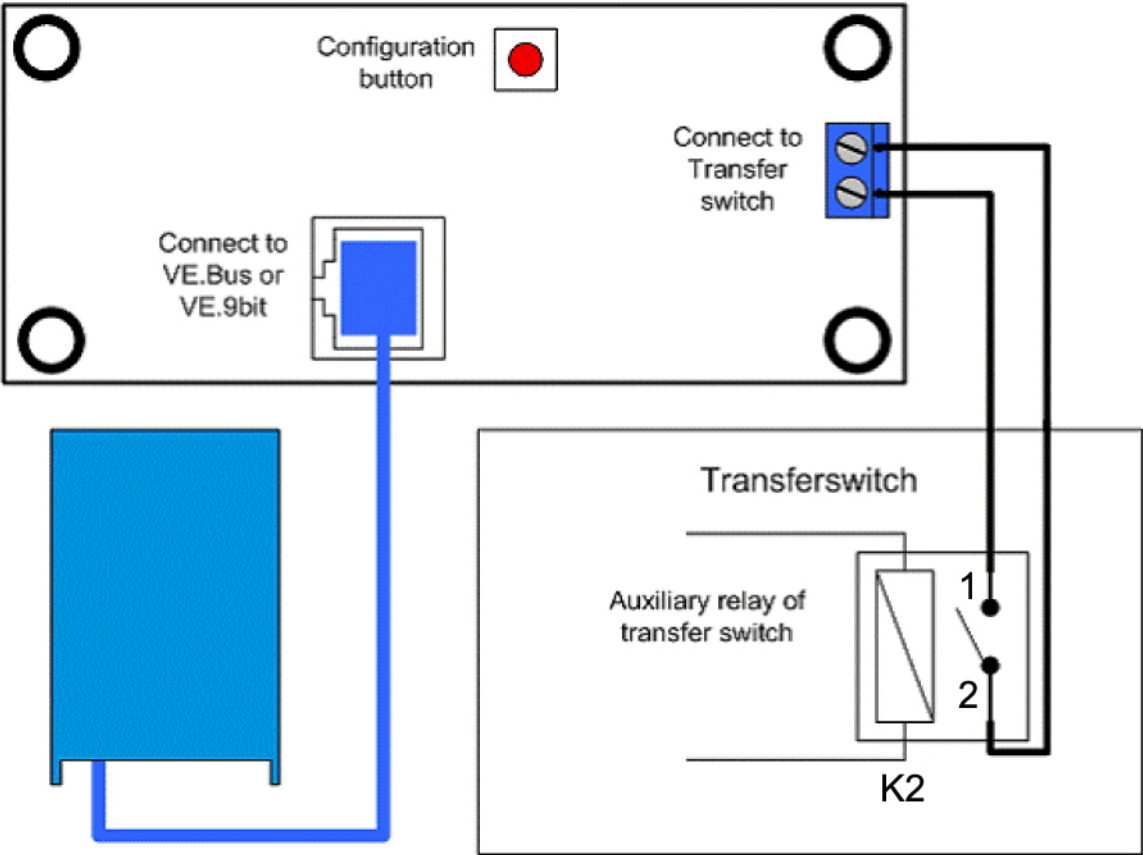

Victron Energy Blue Power

Distributor:

Serial number:

Version : 02
Date : April 21st, 2017

Victron Energy B.V.
De Paal 35 | 1351 JG Almere
PO Box 50016 | 1305 AA Almere | The Netherlands

General phone : +31 (0)36 535 97 00
Fax : +31 (0)36 535 97 40

E-mail : sales@victronenergy.com

www.victronenergy.com