

# Lynx Smart BMS

# Table of Contents

<b>1. Introduction</b>	<b>1</b>
1.1. The Lynx Smart BMS	1
<b>2. Features</b>	<b>2</b>
2.1. Battery Management System	2
2.2. Contactor	2
2.3. Built-in pre-charge circuit	2
2.4. Battery Monitor	2
2.5. Programmable relay	2
2.6. AUX terminal	2
<b>3. Communication and interfacing</b>	<b>3</b>
<b>4. System Design considerations and examples</b>	<b>4</b>
4.1. Integration into the Lynx Distributor System	4
4.2. System sizing	5
4.2.1. Current rating Lynx Smart BMS	5
4.2.2. Fusing	5
4.2.3. Cabling	5
<b>5. Installation</b>	<b>6</b>
5.1. Safety Precautions	6
5.1.1. Safety Warnings Lynx Distribution System	6
5.2. Mechanical connections	6
5.2.1. Lynx Smart BMS connection features	6
5.2.2. Mounting and interconnecting Lynx modules	7
5.3. Electrical connections	7
5.3.1. Connect DC wires	7
5.3.2. Connect RJ10 cable(s)	8
5.3.3. Connect BMS cables	8
5.3.4. Connect the Multi connector	9
5.3.5. Connect ATC/ATC controlled loads and chargers	9
5.3.6. Wiring a Remote on/off switch	10
5.3.7. Programmable relay wiring	10
5.3.8. Connect the GX device	11
5.4. System examples in detail	11
5.4.1. Lynx Smart BMS, 2x Lynx Distributor and lithium batteries	11
5.4.2. Lynx Smart BMS, 1x Lynx Distributor and lithium batteries	12
5.4.3. Lynx Smart BMS only	13
<b>6. Configuration and settings</b>	<b>14</b>
6.1. Power up for the first time	14
6.2. Update firmware	14
6.3. Lynx Smart BMS settings	14
6.4. Lynx Distributor settings	16
<b>7. Commissioning and Operation of the Lynx Smart BMS</b>	<b>18</b>
7.1. Commissioning the Lynx Smart BMS	18
7.2. Powering up	18
7.3. BMS operating modes	20
7.4. Lynx Smart BMS trigger	21
7.5. Battery monitor operation	21
7.6. Battery care	21
7.7. VictronConnect-Remote (VC-R) support*	22
7.8. VictronConnect Instant readout*	22
<b>8. Troubleshooting and Support</b>	<b>23</b>
8.1. How to recover from OFF mode when no charge voltage was detected	23
8.2. Lynx Smart BMS does not power up	23
8.3. Lynx Smart BMS operational issues	24

8.4. BMS issues .....	25
8.4.1. The BMS frequently disables the battery charger .....	25
8.4.2. The BMS is prematurely turning loads off .....	25
8.4.3. The pre-alarm setting is missing in VictronConnect .....	25
8.4.4. BMS is displaying alarm while all cell voltages are within range .....	25
8.4.5. How to test if the BMS is functional .....	26
8.4.6. System in OFF mode .....	26
8.4.7. ATC/ATD is missing .....	27
8.5. Battery monitor issues .....	27
8.5.1. Incomplete current reading .....	27
8.5.2. Incorrect state of charge reading .....	27
8.5.3. State of charge does not increase/decrease fast enough or too fast when charging/discharging. ....	27
8.5.4. Synchronisation issues .....	27
8.6. VictronConnect issues .....	28
8.7. GX device issues .....	28
<b>9. Warranty .....</b>	<b>29</b>
<b>10. Technical specifications .....</b>	<b>30</b>
<b>11. Appendix .....</b>	<b>31</b>
11.1. LED indications, warnings, alarm and error codes .....	31
11.2. Supported NMEA 2000 PGNs .....	34
11.3. List of battery monitor settings .....	34
11.4. Multi connector pin-out and overview .....	35
11.5. Lynx Smart BMS related menu structure of the GX device .....	35
11.6. Enclosure dimensions .....	37

# 1. Introduction

## 1.1. The Lynx Smart BMS

The Lynx Smart BMS is a dedicated Battery Management System for [Victron Lithium Smart Batteries](#). There are multiple BMS-es available for our Smart Lithium series of batteries, and the Lynx Smart BMS is the most feature rich and complete option. Its main features are:

- Built-in 500A contactor used as a fallback safety mechanism and also suitable as a remote controllable main system switch.
- Battery monitor, indicating state of charge percentage and more data.
- Pre-alarm signal: provide a warning before the system shuts down due to a low cell voltage.
- Bluetooth for use with our [VictronConnect App](#), for setup, monitoring and diagnostic.
- Local and remote monitoring using a Victron GX device, for example the [Cerbo GX](#) and our [VRM portal](#).

The Lynx Smart BMS integrates seamlessly into [our Lynx Distributor system](#).

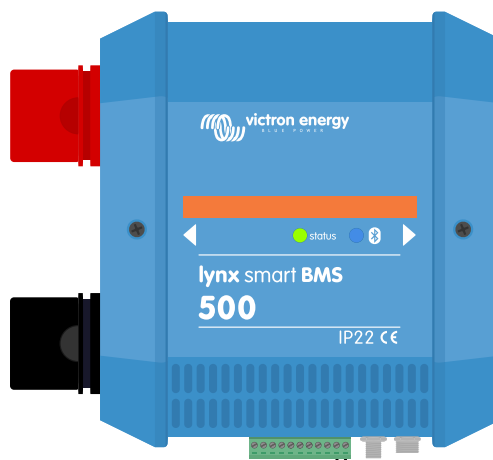

Lynx Smart BMS

## 2. Features

### 2.1. Battery Management System

The BMS is used to monitor, control and protect your Victron Lithium Batteries Smart. It detects the state of charge and protects against deep discharge and overcharging.

It's main features are:

- **Pre-alarm mode** configurable via the programmable relay
- **ATC/ATD ports** to control chargers and loads
- **DVCC support** for compatible Victron inverter/charger and MPPTs via a connected GX device
- **Discharge floor** used to set the minimum SoC to determine how far the battery is allowed to be discharged. (requires VictronConnect v5.70 or later)

A configurable pre-alarm warns with a minimum delay of 30 seconds of an imminent shutdown of the loads as a result of an impending low cell voltage. By reacting quickly on the pre-alarm, for example by reducing the load or starting a generator to charge the batteries, the shutting down of the loads can be prevented.

The ATC contact is opened to stop charging at high cell voltage or low temperature, while the ATD contact is opened to stop discharging at a low cell voltage.

DVCC controls compatible devices via Lynx Smart BMS and a connected GX device. Charging current and voltages are set automatically, thus Bulk, Absorption and Float algorithms are no longer used. Charging or discharging are stopped at low or high cell voltage or low temperature.

### 2.2. Contactor

The built-in contactor serves two purposes:

1. It acts as a secondary safety system to protect the battery in case the primary controls (ATC and ATD contacts as well as DVCC) fail to disable the loads and/or chargers when required.
2. It can be used as a remote controlled main system on/off switch via the VictronConnect app, a GX device (only Standby and On), as well as using the Remote on/off terminals.

### 2.3. Built-in pre-charge circuit

The built-in pre-charge circuit pre-charges capacitive loads such as inverters or inverter/chargers before the contactor closes to prevent high inrush current.

### 2.4. Battery Monitor

The Lynx Smart BMS battery monitor operates in a similar fashion as the other [Victron Energy battery monitors](#). It contains a shunt and battery monitor electronics. Readout of the battery monitor data is via Bluetooth using the VictronConnect App or a GX device and the VRM portal.

### 2.5. Programmable relay

The Lynx Smart BMS has a programmable relay that can be used as an alarm relay (combined with the pre-alarm) or to shut down an alternator via its external regulator (ignition wire).

### 2.6. AUX terminal

The Lynx Smart BMS is equipped with an auxiliary power supply. This supply outputs the same voltage as the system battery voltage and is rated at a maximum continuous current rating of 1.1A.

The purpose of the auxiliary power supply is to keep certain systems powered, for example a GX device, after the BMS has turned off loads in case of a low cell voltage event.



It is recommended that the system includes a GX device powered by the AUX port. This keeps the GX device supplied with power until the AUX port is finally switched off (max. 2 hours after a low cell voltage event) to preserve energy.

### 3. Communication and interfacing

The Lynx Smart BMS communicates with other devices and services via a variety of interfaces. The following list provides an overview of the most important interfaces:

- **Bluetooth:** to change settings and monitor the Lynx Smart BMS via [our VictronConnect App](#).  
Note that Bluetooth can be disabled via VictronConnect or a GX device, but can only be re-enabled from a GX device.
- **VE.Can:** to connect a GX device to the Lynx Smart BMS. The GX device will show all measured parameters, operational state, battery SoC and alarms and make them available to be controlled via our remote monitoring [VRM portal](#).
- **Lynx Distributor fuse monitoring:** via our VictronConnect app and a connected GX device. Communication with the Lynx Distributors is via it's RJ10 connectors. The Lynx Smart BMS can be used to read out the Lynx Distributors, generate alarms in case a fuse is blown or communication is lost. Fuse status communication requires Lynx Distributor with serial number HQ1909 or later.
- **NMEA 2000 via VE.Can:** Communication to an NMEA 2000 network can be established via VE.Can using a [VE.Can to NMEA2000 micro-C cable](#). See the [Appendix for supported PGNs \[34\]](#).

## 4. System Design considerations and examples

### 4.1. Integration into the Lynx Distributor System

The Lynx Smart BMS integrates seamlessly with the [Lynx Distributor](#) system, which is not mandatory for operation, but highly recommended due to its ease of installation.

It is important to note that the battery must always be connected to the left side of the Lynx Smart BMS (in normal position), while all loads and chargers are connected to the right side.

The example below shows the Lynx Smart BMS in a system with two Lynx Distributors. Together they form a continuous busbar with fused battery connections, battery monitor, BMS system, contactor and fused load connections.

The Lynx modules can be mounted in any orientation. Should they be mounted upside down, so that the text on the front of the units is upside down as well, use the special stickers are included with each Lynx module, so that the text is orientated the correct way.

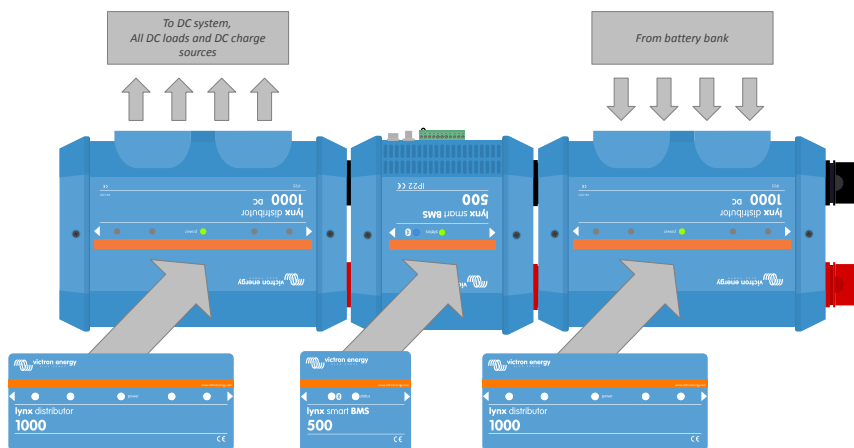
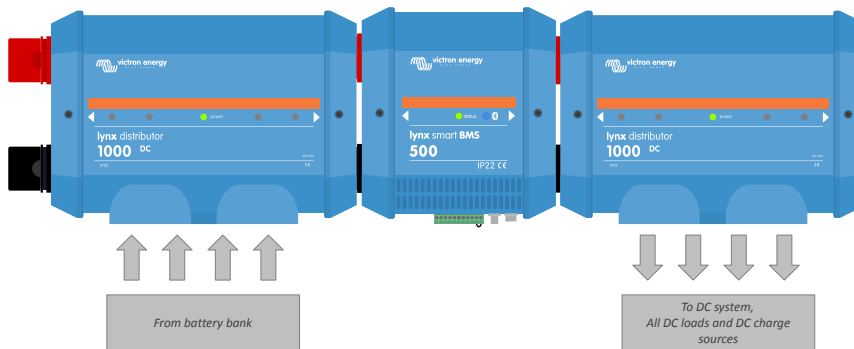
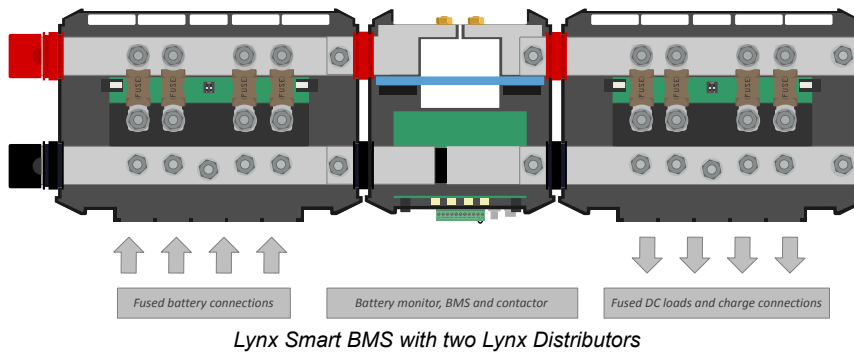

It is important to note that the battery is always connected to the left side of the Lynx Smart BMS (in normal position), while all loads and chargers go to the right side.

## 4.2. System sizing

### 4.2.1. Current rating Lynx Smart BMS

The main safety contactor of the Lynx Smart BMS has a continuous current rating of 500A and a peak current rating of 600A for a duration of 5 minutes. Even if the Lynx Smart BMS has an overcurrent protection, make sure that the current rating is not exceeded.

The following happens in the event that the peak current limit or the 5 minute interval has been exceeded:

- an overcurrent alarm will be generated
- ATC or ATD (depending on current direction) is disabled after a 30s delay

It is not possible to parallel multiple Lynx Smart BMS modules. Only a single Lynx Smart BMS can be used per system.

The table below gives an idea of how much power a Lynx Smart BMS is rated for at different voltages. This will give you an indication how big the connected inverter/charger system can be. Keep in mind that if inverters or inverter/chargers are used, both the AC and the DC system will be powered from the batteries.

Voltage vs. Current	12V	24V	48V
500A	6kW	12kW	24kW

### 4.2.2. Fusing

The Lynx Smart BMS is not a system fuse. It only warns when the current is too high. Fusing needs to be done externally, for example by connecting Lynx Distributor modules to the Lynx Smart BMS or by using [external fuse holders and fuses](#).

Always use fuses with the correct voltage and current rating. Match the fuse rating to the maximum voltages and currents that potentially can occur in the fused circuit. For more information on fuse ratings and fuse current calculations see the [Wiring Unlimited book](#).



The total value of the fuses of all circuits should not be more than the current rating of the Lynx module, or the Lynx model with the lowest current rating in case of multiple Lynx modules are used.

### 4.2.3. Cabling

The current rating of the wires or cables used to connect the Lynx Smart BMS to batteries and/or the DC loads, has to be rated for the maximum currents that can occur in the connected circuits. Use cabling with a sufficient core surface area to match the maximum current rating of the circuit.

For more information on cabling and cable thickness calculations see our book, [Wiring Unlimited](#).



## 5. Installation

### 5.1. Safety Precautions

#### 5.1.1. Safety Warnings Lynx Distribution System



- Installation must strictly follow the national safety regulations in compliance with the enclosure, installation, creepage, clearance, casualty, markings and segregation requirements of the end-use application.
- Installation must be performed by qualified and trained installers only.
- Do not work on live busbars. Ensure that the busbar is unpowered by disconnecting all positive battery poles prior to removing the Lynx front cover.
- Work on batteries should be carried out by qualified personnel only. Observe the battery safety warnings as listed in the battery manual.
- Store this product in a dry environment. The storage temperature should be  $-40^{\circ}\text{C}$  to  $+65^{\circ}\text{C}$ .
- No liability can be accepted for damage in transit, if the equipment is not transported in its original packaging.

### 5.2. Mechanical connections

#### 5.2.1. Lynx Smart BMS connection features

- The Lynx Smart BMS cover can be opened up by unscrewing the two cover screws.
- Removable rubber sleeves to protect the busbar ends.

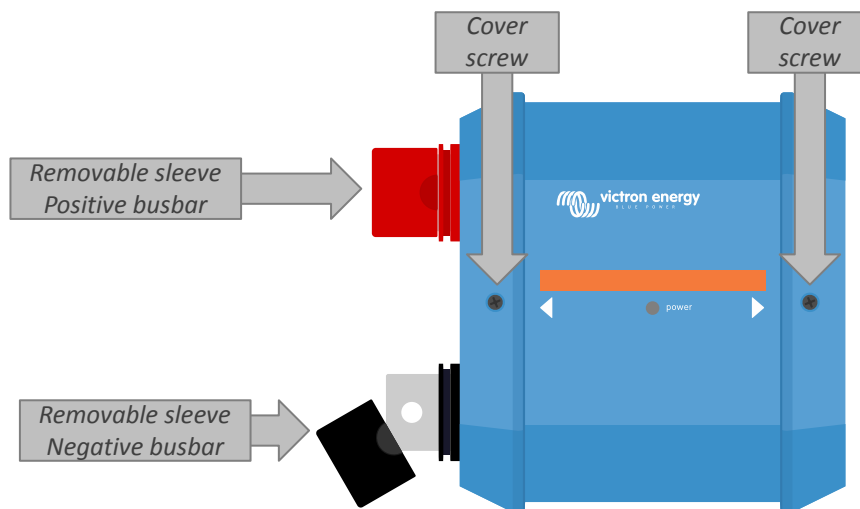

Location of front cover screws and the removable sleeves

## 5.2.2. Mounting and interconnecting Lynx modules

This paragraph explains how to attach several Lynx modules to each other and how to mount the Lynx assembly into its final location. These are the points to take into consideration when interconnecting and mounting Lynx modules:

- If Lynx modules are going to be connected to the right and if the Lynx module is fitted with a plastic barrier on the right side, remove the black plastic barrier. If the Lynx module is located as the most right module, leave the black plastic barrier in place.
- If Lynx modules are going to be connected to the left, remove the red and black rubber sleeves. If the Lynx module is located as the most left module, leave the red and black rubber sleeves in place.
- Remember that for a Lynx Smart BMS, the left side is the battery side and the right side is the DC system side.
- Connect all Lynx modules to each other using the M8 holes and bolts on the left and right. Take care that the modules correctly slot into the rubber joiner recesses.
- Place the washer, spring washer and nut on the bolts in the correct order and tighten the bolts to a **torque of 14Nm**.
- Mount the Lynx assembly in its final location using the 5mm mounting holes.

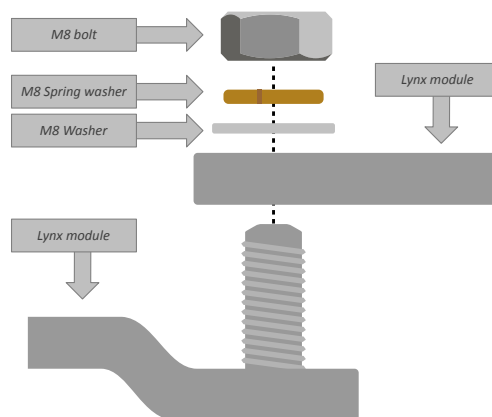

Connection sequence when connecting two Lynx modules

## 5.3. Electrical connections

### 5.3.1. Connect DC wires

For all DC connections the following applies:

- All cables and wires connected to the Lynx module need to have been fitted with M8 cable lugs.
- Pay attention to the correct placement and order of the cable lug, washer, spring washer and nut on each bolt when attaching the cable to the bolt.
- Tighten the nuts with a **torque of 14Nm**.

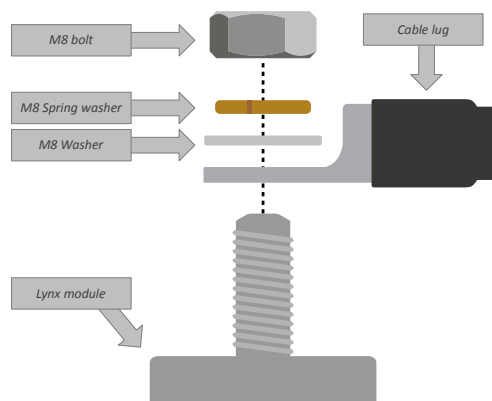

Correct placement of the M8 Cable lug, washer, spring washer and nut

### 5.3.2. Connect RJ10 cable(s)

These instructions only apply, if the system contains Lynx Distributor(s).

There are two RJ10 connectors in each Lynx module, one on the left and one on the right. See below drawing.

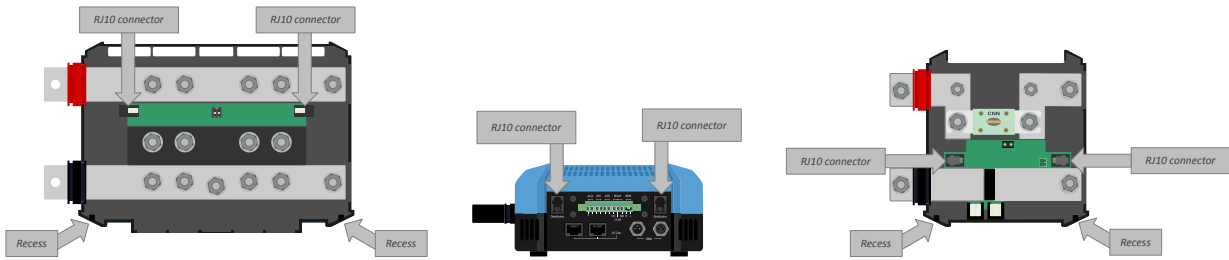

Locations of the RJ10 connectors and RJ10 cable recesses on the Lynx Distributor, Lynx Smart BMS and the Lynx VE.Can

To connect the RJ10 cables between the Lynx Smart BMS and Lynx Distributor, do the following:

- Plug one side of the RJ10 cable in the RJ10 connector of the Lynx Distributor, with the retainer clip of the RJ10 connector facing away from you.
- Feed the RJ10 cable through the recess at the bottom of the Lynx Distributor, see above picture.
- Plug the RJ10 cable into the RJ10 connector at the bottom of the Lynx Smart BMS.

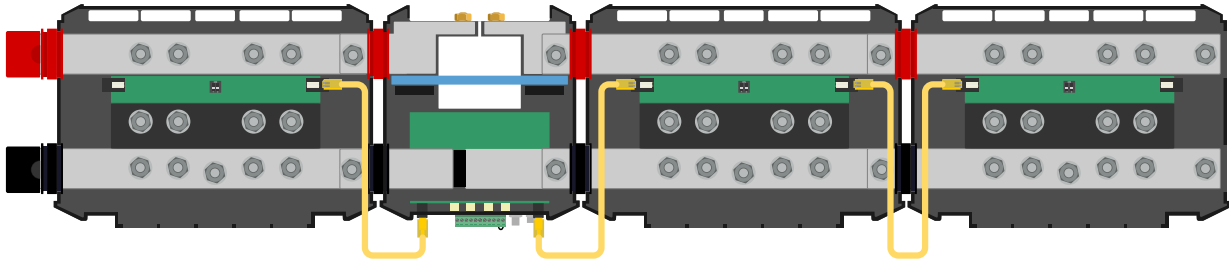

Connection example Lynx Smart BMS system - RJ10 cables indicated in yellow

### 5.3.3. Connect BMS cables

Connect the BMS cables from the lithium battery to the BMS connectors on the Lynx Smart BMS.

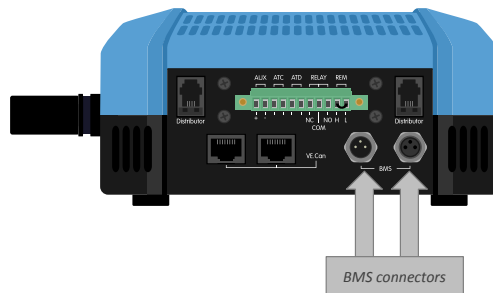

Location of the BMS cable connectors

In case multiple batteries (up to 26 batteries can be connected to the BMS) are used, first interconnect the battery BMS cables and then connect the BMS cable from the first and last battery to the BMS connectors on the Lynx Smart BMS.

If the BMS cables are too short, use [BMS extension cables](#).

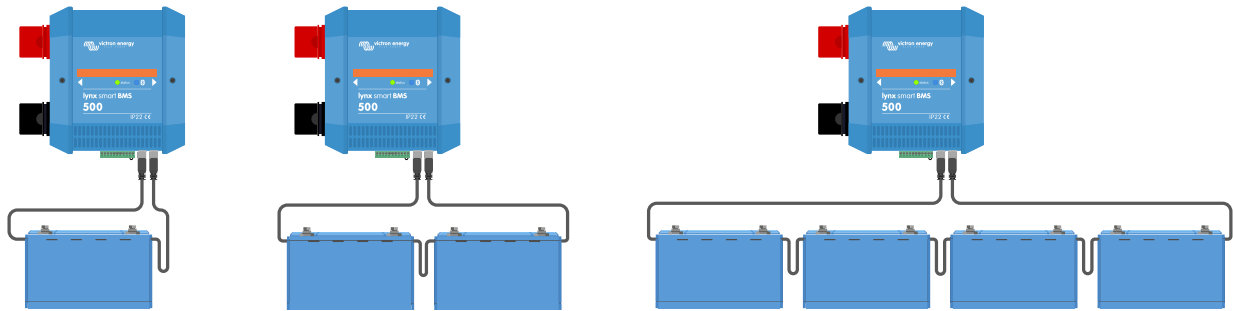

Lynx Smart BMS battery BMS cable connection examples

### 5.3.4. Connect the Multi connector

The multi connector is the green connector on the bottom of the Lynx Smart BMS. The connector has 11 pins, numbered from left to right starting with pin 1 and ending with pin 11.

See the Appendix for a [table with pin-out and description \[35\]](#).

The multi connector's screw terminal can be pulled out of the Lynx Smart BMS, allowing for easy wiring.

The Remote on/off (pin 10 and 11) of the terminal are interconnected with a wire loop by default. If the Remote on/off connection is used with a simple on/off switch, remove the loop and wire as desired.

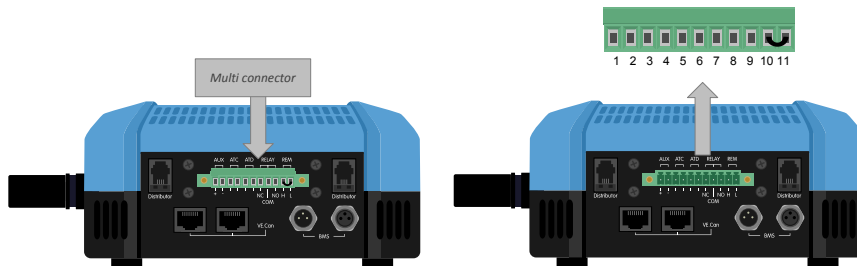

Multi connector location

### 5.3.5. Connect ATC/ATD controlled loads and chargers

The ATC (allow-to-charge) and ATD (allow-to-discharge) are potential free dry contacts of the multi connector that can control chargers and loads in the system, provided they have a remote on/off connector and are wired appropriately. They can be used in several ways.

A common example is by providing +12V wired from AUX + (equal to system voltage) to pin 3 and pin 5. An active high signal is then delivered to the connected remote H ports of the chargers and loads via pin 4 respectively pin 6. In case of a low cell voltage, ATD opens the contact between pin 5 and pin 6. The load is then switched off and further discharge is prevented. If the temperature is too low to charge, the ATC contact between pin 3 and pin 4 opens and switches off the chargers.

Instead of using system voltage on AUX +, system minus can be used on AUX - to generate an active L signal. The functionality is the same as described above, except that the low signal ensures that the loads and chargers are switched off. This active L signal then can be connected to the remote L terminals of a charger or load. In contrast to the H signal, System minus is also present in case the contactor opens and the Lynx Smart BMS goes into OFF mode.

Another option is to use the ATC and ATD contacts as remote switches, for example to control a Smart BatteryProtect to turn off loads in the event of low cell voltage or a charger in the event of low temperature.

See below examples for wiring:

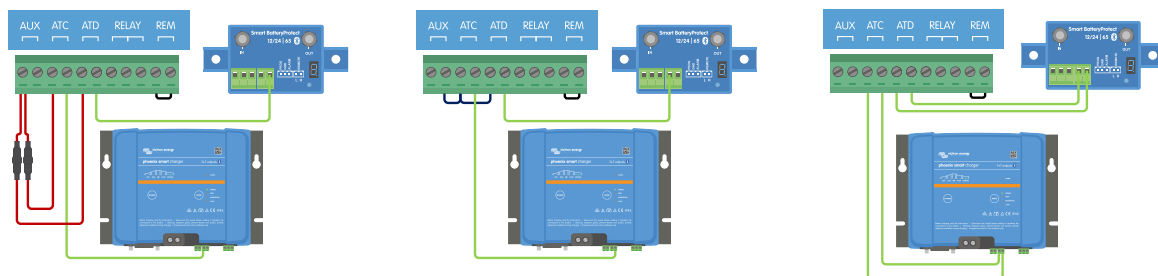

 For the system to operate correctly, it is essential that all loads and chargers are able to be controlled by either DVCC or the ATC and ATD signals. Ideally wire the ATC and ATD signals to a devices remote on/off connector, or, if that is not available, a [Smart BatteryProtect](#) or [Cyrix-Li](#) can be used.

**5.3.6. Wiring a Remote on/off switch**

Instead of the pre-installed wire loop between pin 10 and pin 11, a simple on/off switch can be wired to remotely turn the Lynx Smart BMS on and off.

See below example for correct wiring:

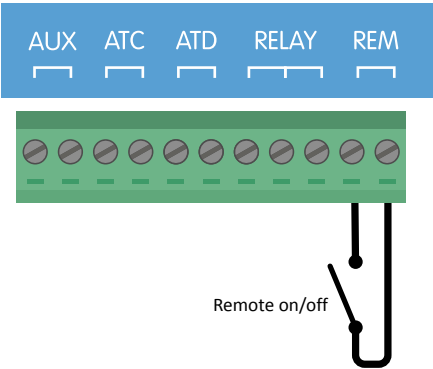

*Simple Remote on/off switch wired between pin 10 and pin 11*

 For the Lynx Smart BMS to operate, the contact between pin 10 and pin 11 must be closed.

**5.3.7. Programmable relay wiring**

The programmable relay is an SPDT relay (Single Pole, Double Throw) with 3 contacts:

- Common (COM)
- Normally Open (NO)
- Normally Closed (NC)

The relay makes contact between COM and NC when the relay is not active, while COM and NO makes contact when the relay is activated.

Depending on the Relay mode setting (Alarm relay or Alternator ATC) in the VictronConnect app, an audible (buzzer or external speaker) or visible device (LED signal) or the signal line (usually the ignition wire) for the ATC signal of an external alternator regulator can be connected.

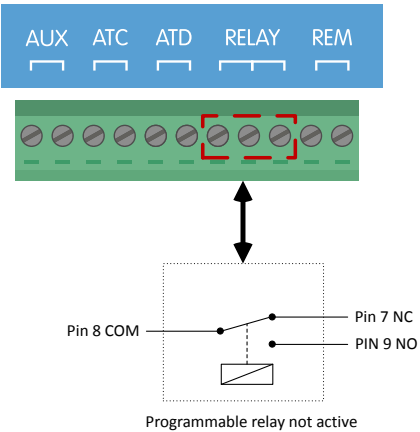

*Pinout for the programmable relay*

### 5.3.8. Connect the GX device

Connect the Lynx Smart BMS VE.Can port to the GX device VE.Can port using a RJ45 cable.

Multiple VE.Can devices can be daisy chained, but make sure that the first and the last VE.Can device both have a VE.Can RJ45 terminator installed.

Power the GX device from the AUX + and AUX – terminal of the Lynx Smart BMS.

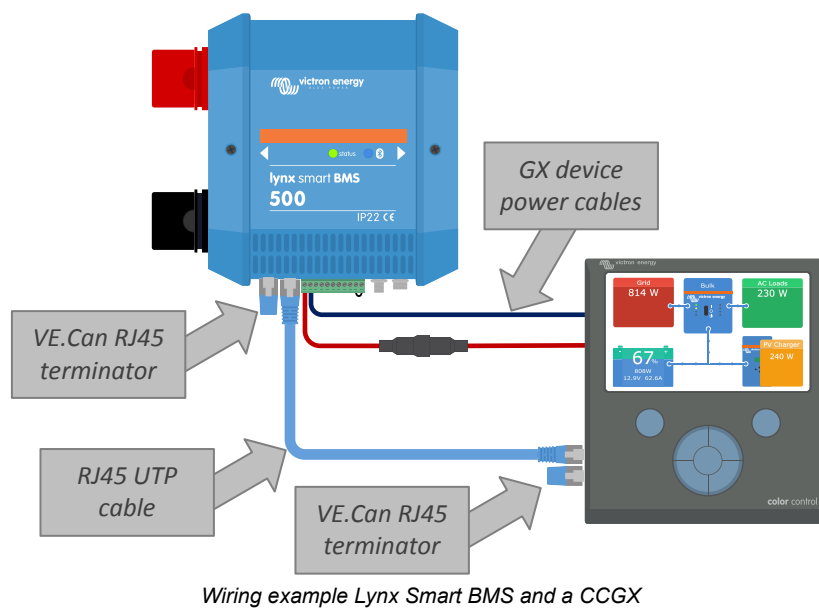
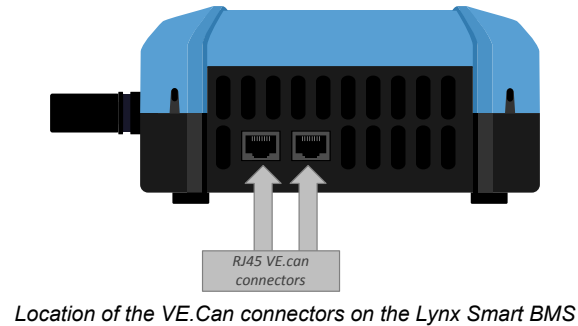

## 5.4. System examples in detail

### 5.4.1. Lynx Smart BMS, 2x Lynx Distributor and lithium batteries

A Lynx Smart BMS with two Lynx distributors and a Cerbo GX with GX touch panel form the heart of this system. They continuously monitor the batteries, fuses, connected loads, chargers and inverter/charger(s).

A typical system can contain the following components:

- Lynx Smart BMS with built-in contactor and battery monitor.
- Lynx Distributor with 2 fused paralleled lithium batteries and identical cable lengths for each battery (up to 5 paralleled series strings can be used per system).
- Lynx Distributor with fused connections for chargers, inverter/charger(s) and loads.
- A Cerbo GX (or other GX device).

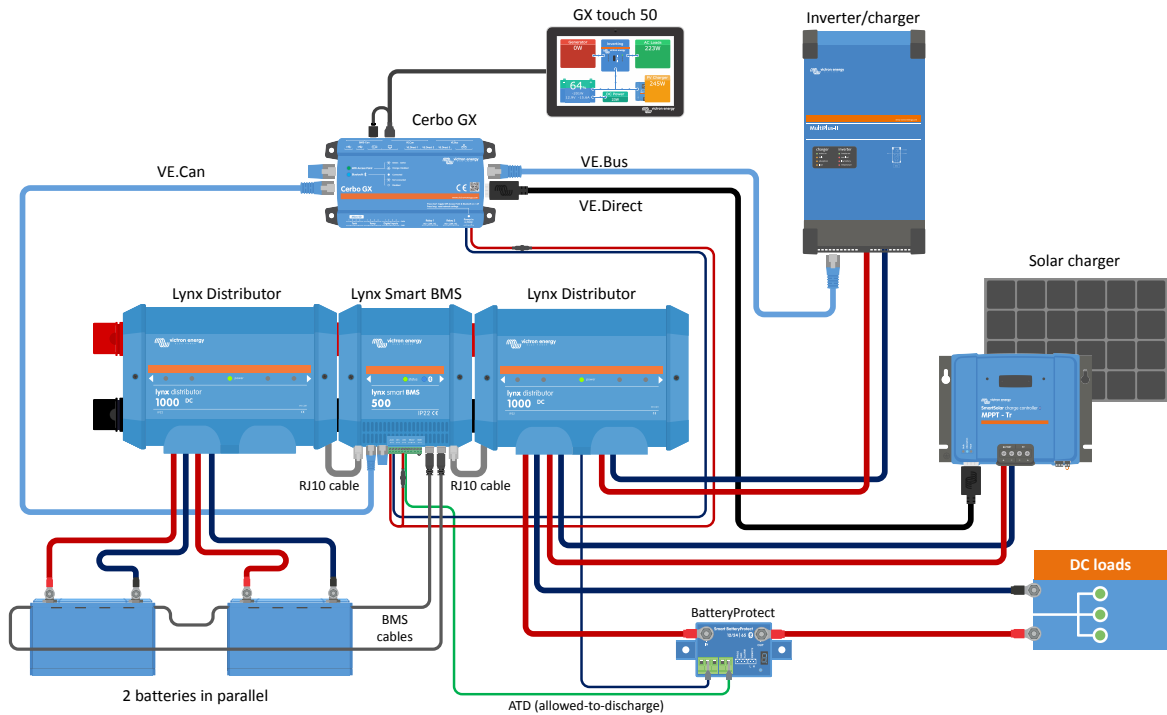

System with Lithium batteries, Lynx Smart BMS and two Lynx Distributors

#### 5.4.2. Lynx Smart BMS, 1x Lynx Distributor and lithium batteries

The same as before, but this time with a single Lynx Distributor on the load side of the Lynx Smart BMS and the lithium battery connected directly to the input of the Lynx Smart BMS. This is useful if only a single lithium battery or a single series string of lithium batteries is used. Otherwise the same components are used.

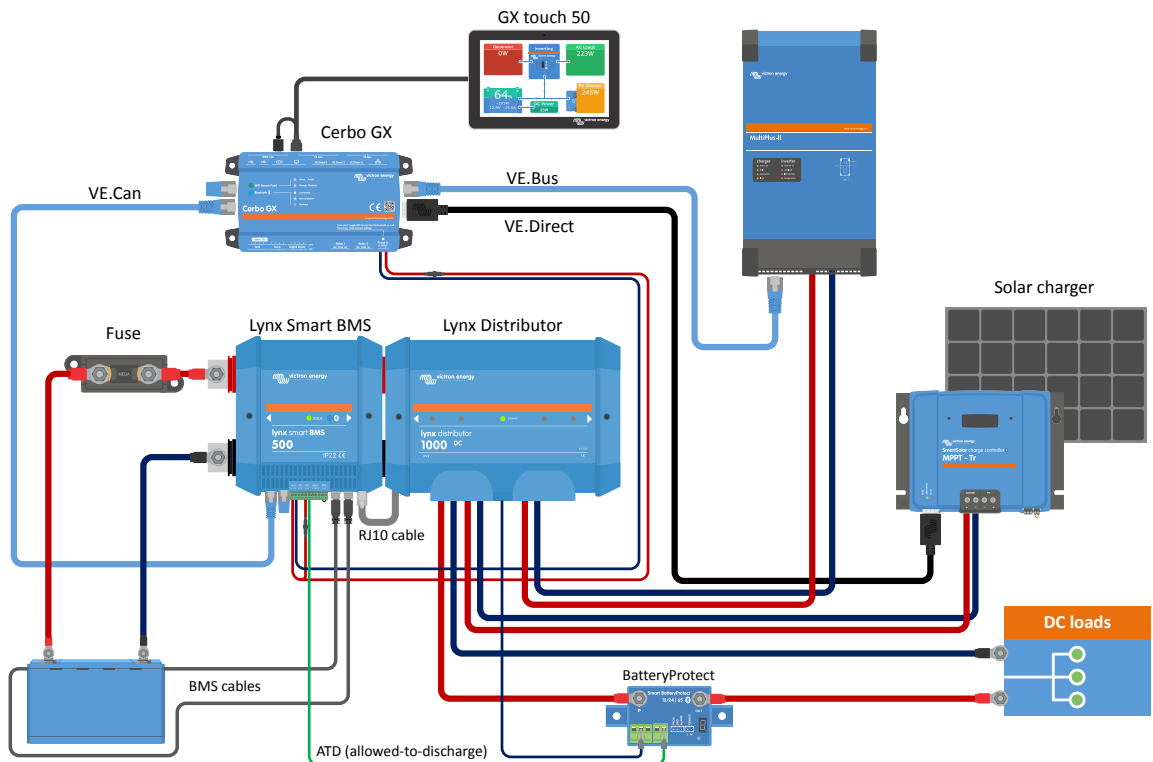

System with a Lynx Smart BMS and a single Lynx Distributor

### 5.4.3. Lynx Smart BMS only

For a very slim line system, the Lynx Smart BMS can be used just by itself. This is useful if the system contains a single lithium battery or a single series string of lithium batteries together with a simple DC system.

Please also note that no GX device is used. It is not absolutely necessary for the operation of the Lynx Smart BMS. However, without GX device it is not possible to control compatible inverter/chargers and MPPTs via DVCC.

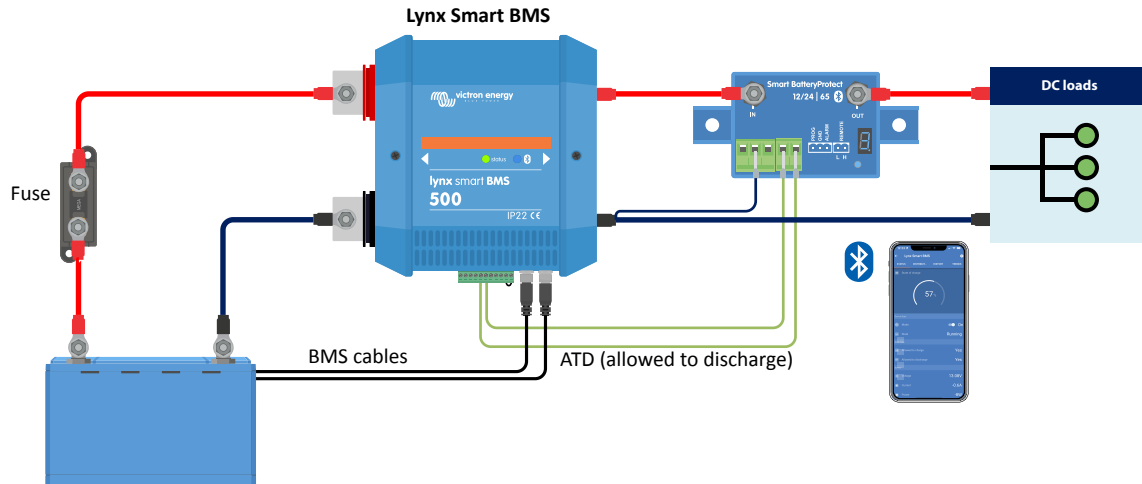

System with a Lynx Smart BMS, without other Lynx modules and GX device.



## 6. Configuration and settings

### 6.1. Power up for the first time

The Lynx Smart BMS will power up when a battery is connected and the wire loop is placed in between pin 10 and 11 of the multi connector or the Remote on/off switch is switched on.

On first power up and after a "Reset to defaults" (via VictronConnect app), the Lynx Smart BMS automatically determines and sets these settings:



- System voltage, 12, 24 or 48V, by measuring the battery voltage.
- Pre-alarm support in the batteries.

The settings can also be reviewed and changed manually.

### 6.2. Update firmware

On a new install, it is recommended to update the firmware of the Lynx Smart BMS. If there is a newer firmware version available, the VictronConnect app will notify you of this as soon as a connection with the Lynx Smart BMS is made.

To check if the firmware is up to date or to manually update firmware, connect to the Lynx Smart BMS using the VictronConnect app and follow below steps:

1. Navigate to the product settings by clicking the cogwheel  icon in the top right hand corner of the product status screen.
2. Click on the 3 dots  icon in the top right hand corner of the settings screen.
3. Select "Product info" from the pop-up menu.
4. The firmware version will be displayed. It is mentioned whether this is the latest firmware version. If a newer firmware version is available, an "UPDATE" button will appear.
5. To update the firmware, press the "UPDATE" button.

The firmware update is even easier via the [VRM: Remote firmware update](#) feature (requires a GX device in the system and internet connection).

In case of a new installation, it is also recommended to check and update the firmware of each connected lithium battery. This is done via Bluetooth using the VictronConnect app in a similar manner to that outlined above.



Updating the firmware always starts a new full charging cycle despite the SoC threshold setting, which means that the charge voltage limit (CVL) is automatically adjusted from 13.5V to 14.2V (for a 12V system).

### 6.3. Lynx Smart BMS settings

Once powered up, use the VictronConnect app to configure the BMS settings.

#### Check the Battery voltage setting (12, 24 or 48V):

- This will have been detected automatically, double check it.

#### Set the Battery capacity setting:

- Enter the total battery bank capacity of the connected battery. Caution, for batteries connected in series, do not add the capacity of each battery to determine the total capacity of the bank.
- Check out our book [Wiring Unlimited](#) section 3.1 to learn how to determine battery capacity.



If the battery capacity input is incorrect, the SoC will also be incorrectly calculated. Make sure the battery capacity calculation is correct.

#### Set the Number of batteries in parallel :

- Enter the number of paralleled batteries in the system.



The wrong number of parallel batteries will lead to a miscalculation of the balancing algorithm. Make sure this value is entered correctly.

#### Check the Pre-alarm mode setting:

This setting is automatically configured upon initial power-up and after a "Reset to defaults". It is enabled by default.

- enabled: recommended setting. A visual or audible device linked to the programmable relay is activated in case of a pre-alarm.
- disabled: If disabled, it will ignore the discharge current limit at pre-alarm setting.



Older Victron Lithium Batteries Smart manufactured before 2019/2020 do not have the pre-alarm signal. Nevertheless, the Lynx Smart BMS also generates the pre-alarm signal for these batteries with the restriction that the threshold for this is derived from the undervoltage alarm setting (in the battery) of 2.6V - 2.8V. The undervoltage alarm then occurs with a fixed delay of 30 seconds after pre-alarm.

#### Set the Relay setting:

The programmable relay has two operation modes: Alarm relay and Alternator ATC.

- When set to Alarm relay mode, the Alarm relay setting becomes active and continuous or intermittent operation can be selected. In intermittent operation the relay switches on and off every 0.8 seconds.
- When configured for Alternator ATC mode, the relay will only activate when the contactor is closed. Before the contactor is opened, Alternator ATC is opened first and 2 seconds later the contactor. These 2 seconds ensure that the alternator is switched off before the battery is disconnected from the system.

#### DVCC settings:

DVCC is forced on and cannot be turned off. However, a few settings can be changed, which are described below.

Please note that these settings only affect compatible DVCC devices such as Victron inverter/chargers and Solar MPPT chargers.

- **Discharge Current Limit at pre-alarm** (default "No"): if set to "Yes", the discharge current limit is already set to 0A in the event of a pre-alarm, while the ATC contact remains closed. In this way it's possible to save some battery power for essential DC loads, for example on boats such as lighting, bilge pump and navigation.
- **Absorption time:** is set to 2 hours by default. This can be adjusted if necessary.
- **Repeated absorption interval:** in days at which a new full charging cycle is started, if the battery SoC does not fall below the SoC threshold. The default is every 30 days and can be adjusted if required.
- **SoC threshold:** is set by default to 70%. This is the threshold at which the Lynx Smart BMS starts a new full charging cycle. This can be adjusted if required.

A new charge cycle means that the CVL (charge voltage limit) is increased from 13.5V (for a 12V battery) to 14.2V.

In addition to the SoC threshold, a new charging cycle is started after a firmware update, when the battery voltages are below 12V/24V/48V (3V per cell) or when a low cell voltage is detected.

#### Battery monitor settings:

Unlike other battery monitors, the Lynx Smart BMS battery monitor settings are mostly fixed settings and are not customisable. The reason for this is that the Lynx Smart BMS is always used together with Victron Lithium Batteries Smart and a lot of battery monitor parameters are therefore known because they relate to the battery type.

The following settings are adjustable. A full list of all settings used can be found in the [Appendix section 10.3. \[34\]](#)

- **Charged voltage:** the voltage at above which the battery monitor synchronises and resets the SoC to 100%. For synchronisation to happen, the tail current and charged detection time conditions need to have been met as well. The default is set to 14.0V and can be adjusted if necessary. In case the system voltage setting is changed, the charged voltage setting needs to be adjusted as well.
- **Tail current:** the current at below which the battery monitor synchronises and resets the SoC to 100%. For synchronisation to happen, the charged voltage and charge detection time conditions need to have been met as well. The default is set to 4% and can be adjusted if needed.
- **Charged detection time:** is the time passed after which the battery monitor synchronises and resets the SoC to 100%. For synchronisation to happen, the charged voltage and tail current conditions need to have been met as well. The default is set to 3 minutes and can be adjusted if necessary.
- **Discharge floor:**\* this parameter has two functions:
  - Its primary use is to set the minimum SoC to determine how far you want to discharge the battery.
 

A limited depth of discharge is good for battery health, but also provides backup power to keep the system running, e.g. until sunrise for solar systems.

Loads are disabled via ATD or DVCC when the set discharge level is reached, but the contactor remains closed, AUX remains ON and the ATC contact remains closed as well to allow recharging the battery. At the same time, a Low SoC alarm is issued.

Setting the discharge floor to zero (not recommended), disables this feature.



The discharge floor prevents full discharge and should be chosen so that there is enough energy to keep the Lynx Smart BMS powered for 24 hours to provide sufficient time to recharge the battery.

If the battery is not recharged after the discharge floor has been reached, the battery will continue to be discharged through self consumption until a low cell voltage event occurs, at which point the Lynx Smart BMS will go into OFF mode with a delay of 2 hours to prevent deep discharge.

- It is used in the calculation for the 'Time remaining' or 'Time-to-go' value displayed in the VictronConnect app, a connected GX device or on the VRM portal. The battery monitor uses the actual discharge current to calculate the time it takes to reach the set discharge floor.
- **Low SoC warning level:**\* the level at which a warning is issued before the discharge floor has been reached.
- **State of charge:**\* manually set the current state of charge.
- **Synchronise SoC to 100%:**\* manually synchronise SoC to 100%.

\* requires VictronConnect v5.70 or later and Venus OS v2.90 or later

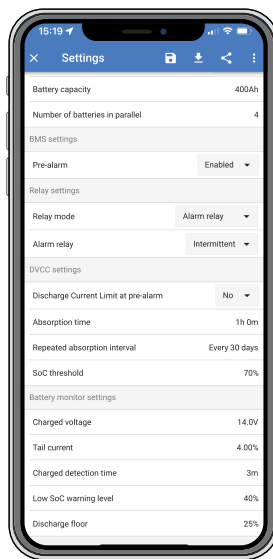

*VictronConnect settings Lynx Smart BMS*

## 6.4. Lynx Distributor settings

These instructions only apply if the system contains one or more Lynx Distributors.

Each Lynx distributor must be addressed and set to A, B, C or D. This is done via a 2-way dip switch located inside the Lynx Distributor. Refer to [chapter 6.1.3. Addressing Lynx Distributor](#) in the Lynx distributor manual.

Use the VictronConnect app to give each fuse a custom name (maximum 16 characters). If the fuse name is empty (0 characters), the fuse will be disabled and ignored for monitoring.

1. Navigate to the Settings page by clicking the cog wheel icon at the top right hand corner.
2. On the Settings page scroll down to the Lynx Distributor settings.
3. Tap on a distributor name. A new menu opens with all 4 fuses.
4. Tap on a fuse to assign a custom name and/or to disable the fuse manually from monitoring.

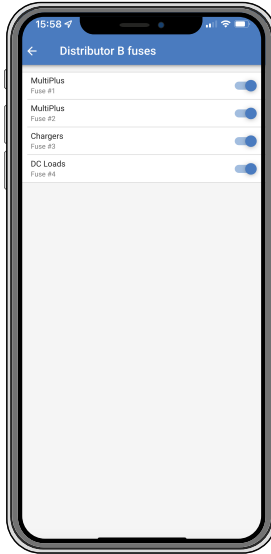
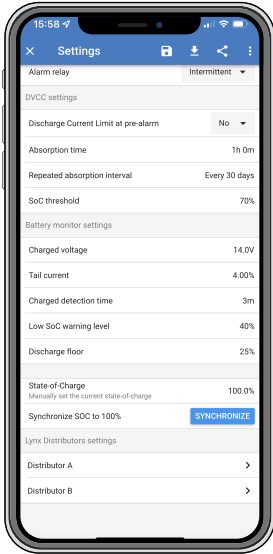

## 7. Commissioning and Operation of the Lynx Smart BMS

### 7.1. Commissioning the Lynx Smart BMS

Commissioning sequence:

- Check polarity of all battery cables.
- Check cross sectional area of all battery cables.
- Check that each battery has the most up to date firmware.
- Check that if batteries have been connected in series, that each battery has been fully pre-charged (refer to battery manual).
- Check if all battery cable lugs have been crimped correctly. Check if all battery cable connections are tight (don't exceed maximum torque). Tug slightly on each battery cable and see if the connections are tight.
- Check all BMS cable connections and make sure the connector screw rings are screwed all the way down.
- Check if each paralleled battery is fused or that each paralleled battery series string is fused.
- If a GX device is used, check if the VE.Can cables and terminator have been placed and the device is powered from the AUX voltage output of the Lynx Smart BMS.
- Power the Lynx Smart BMS by connecting the battery supply or placing the battery fuses and, if applicable, by switching the remote on/off switch to "on".
- Check that the load pre-charge is complete, the contactor is closed, and the loads are energised.
- Connect to VictronConnect and make sure the Lynx Smart BMS has the latest firmware and that all settings have been made, in particular that the battery capacity and the number of paralleled batteries is set correctly.
- Check that the system voltage has been set correctly.
- Check if the fuse names of the Lynx Distributor (if applicable) are correctly named.
- If a GX device is connected, check that it is powered from the Lynx Smart BMS AUX terminals.
- Check that the Lynx Smart BMS displays correctly on the GX device.
- Disconnect a random BMS cable and verify that the BMS is turning off all charge sources and all loads. Reconnect the BMS cable.
- Turn on a load and check that the current is a negative current displayed on the GX device or the VictronConnect app.
- Charge batteries fully and check that a 100% state of charge is displayed

### 7.2. Powering up

The Lynx Smart BMS will power up when a battery is connected to the battery terminals and the Remote on/off switch is turned on (or the wire loop is placed in the remote on/off terminal).

The power up sequence follows these steps:

- **System check:** A self-test that checks the internal and external voltages and contactor.
- **Pre-charge loads:** The pre-charge circuit will pre charge capacitive loads such as inverters or inverter/ chargers before the contactor closes to prevent very high inrush current.
- **Contactor closes:** The Lynx Smart BMS is operational and the power to the Lynx Distributor(s) is turned on.

#### Operational

Once powered up, the contactor is closed. The green status LED together with the blue Bluetooth LED on the Lynx Smart BMS and the green power LED on Lynx Distributor(s) are illuminated.

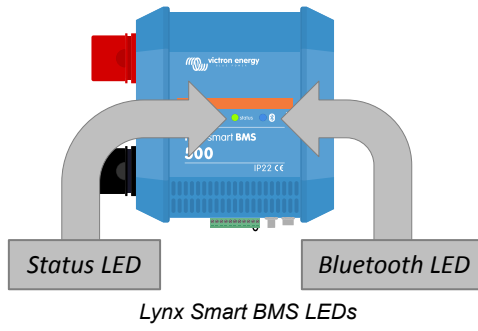

### 7.3. BMS operating modes

The BMS in the Lynx Smart BMS communicates with the batteries and will safeguard them against low or high cell voltage as well as low or high temperatures. Such events are reported by the battery to the Lynx Smart BMS to take necessary action by turning off loads and/or inverter/chargers and chargers and either turning the Lynx Smart BMS off or on again, fully automatically or manually.

The Lynx Smart BMS has 3 modes of operation:

#### ON

This is the normal operating mode. All interfaces are operational, and the contactor is closed. If the Lynx Smart BMS was off due to low cell voltage, it will exit OFF mode and return to ON mode when

- it detects a charge voltage 0.5V higher than the battery voltage on the system side or
- when all cell voltages are higher than 3.2 V or
- when it is turned back on via the Remote on/off switch or
- when it is turned back on via the VictronConnect app.

The mode is also ON for a duration of 2 hours with no charge voltage supplied when a Low Cell Voltage alarm was issued.

#### OFF

Lowest power mode. All interfaces are off, and the contactor is opened. This mode is used to prevent damaging batteries by draining them too low.

OFF is the mode the LSB will enter when using the Remote on/off switch or the soft switch in the VictronConnect App.

In addition, the Lynx Smart BMS goes into OFF mode (to prevent further discharge)) with a 2 hour delay if one or more cells fall below 2.8V (adjustable in battery) and no charging voltage was detected during that time.

#### Standby

The Lynx Smart BMS can be put into Standby mode via the soft switch in the VictronConnect app or via the GX device and is used when the boat is docked or the RV is parked to prevent accidental discharging and charging from sources on the system side. All systems will be shut down, except for equipment powered by the AUX power port from which we recommend for powering the GX device. This mode is not intended to be used when the boat or RV is in storage for a longer period. Therefore, when a low cell voltage is detected, the Lynx Smart BMS will automatically switch to OFF mode to prevent further battery discharge.



The basic requirement for the soft switch to work in VictronConnect or in the GX device is that the contact between pins 10 and 11 of the multi connector is bridged with either a wire loop or a remote on/off switch.

See below tables for an overview of all 3 operating modes, how to switch them manually and the status of the interfaces:

Mode	Main contactor	ATC	ATD	AUX power output	VE.Can port	Bluetooth	Intended use
On	Closed	On	On	Powered	Functional	On	Normal operating mode. All interfaces are operational.
Standby	Open	Off	Off	Powered	Functional	On	All systems will be shut down, except for equipment powered by the AUX power port from which we recommend for powering the GX device.
Off	Open	Off	Off	Off	Off	On	Lowest power mode. All interfaces are off, and the contactor is opened.

Lynx Smart BMS device modes and status of the interfaces

Mode	Soft switch VictronConnect app	Soft switch GX device	Hard wired Remote on/off switch
ON	Yes	Yes*	Yes
Standby	Yes	Yes	No
* Only possible from Standby mode			

Mode	Soft switch VictronConnect app	Soft switch GX device	Hard wired Remote on/off switch
OFF	Yes	No	Yes
* Only possible from Standby mode			

*How to manually switch device modes*

## 7.4. Lynx Smart BMS trigger

This section describes the behavior of the Lynx Smart BMS in case the pre-alarm threshold is reached or either a low or high cell voltage or low temperature event is triggered.

The limits for the pre-alarm threshold, low cell voltage and low temperature are set in the battery.

### Pre-alarm

If a cell voltage drops and reaches the pre-alarm threshold, the programmable relay will activate, if configured to Alarm relay mode. This will give an advanced warning of an impending low cell voltage and before the loads are disabled. Pre-alarm is indicated by the red LED flashing 3 times every 4 seconds. The Lynx Smart BMS ensures a minimum delay of 30 seconds between enabling the pre-alarm and switching off the loads.

### Low cell voltage cut off

If the cell voltage gets too low and has reached the low cell voltage threshold, the ATD contact opens and turns off all loads. If the Lynx Smart BMS is connected to a GX device, DVCC compatible inverters connected to the same GX device are also turned off.

### Low temperature or high cell voltage cut off

If a cell voltage becomes too high and has reached the high cell voltage threshold (3.75V hard coded in battery), or if the low temperature threshold (adjustable in battery) has been reached, the ATC contact opens and will turn off all chargers. If the Lynx Smart BMS is connected to a GX device, DVCC compatible chargers that are connected to the same GX device will be turned off as well.

## 7.5. Battery monitor operation

The Lynx Smart BMS has a built-in battery monitor. It measures battery voltage and current. Based on these measurements it calculates state of charge, time to go and keeps track of historical data, such as deepest discharge, average discharge and number of cycles.

## 7.6. Battery care

Once the Lynx Smart BMS is in operation, it is important to take care of the batteries.

These are the basic guidelines:

- Avoid total discharge of the battery at all times and use the discharge floor setting to prevent this.
- Familiarize yourself with the pre-alarm feature and act when pre-alarm is active to prevent a DC system shutdown.
- Charge your batteries as soon as possible when the pre-alarm is active or the BMS has deactivated loads.
- Minimize the time the batteries spend in a deeply discharged state as much as possible.
- **The batteries need to spend at least 2 hours in absorption charge mode each month to ensure sufficient time in balancing mode.**
- When leaving the system unattended for some time, make sure to either keep the batteries charged during that time or make sure the batteries are (almost) full and then disconnect the DC system from the battery. Do this by disconnecting the positive battery pole.



## 7.7. VictronConnect-Remote (VC-R) support\*

VictronConnect-Remote functionality enables the Lynx Smart BMS to be accessed remotely through a GX product, via the VRM portal.

This powerful feature allows full product configuration (except Bluetooth) and monitoring from practically anywhere in the world using the VictronConnect app. The user interface experience is just like the Lynx Smart BMS were connected locally using Bluetooth.

1. Open the VictronConnect app and tap on the VRM button.
2. Click on the installation that includes the Lynx Smart BMS.
3. Click on the Devices button. A list with all available VE.Direct and VE.Can devices will show up.
4. Tap on the Lynx Smart BMS. The Lynx Smart BMS status screen is now displayed as if it were connected locally using Bluetooth

\*Requires VictronConnect v5.70 or later and Venus OS v2.90 or later

## 7.8. VictronConnect Instant readout\*

Battery voltage, current, state of charge and remaining running time at a glance. See what you want to know in seconds in the VictronConnect app Device list.

The advantage is that the data is available much faster, together with data from other Bluetooth smart devices, and the range exceeds that of a normal Bluetooth connection.

To enable Instant readout:

1. Open the VictronConnect app and tap on the entry for your Lynx Smart BMS.
2. Tap on the cog wheel icon in the top right hand corner.
3. Tap on the 3 dots icon in the top right hand corner. The Product info screen opens.
4. Enable Instant readout by tapping on the slider. Be careful not to disable Bluetooth.
5. Go back to the local device list. Instant readout is now visible to the Lynx Smart BMS.

\* Requires VictronConnect v5.70 or later

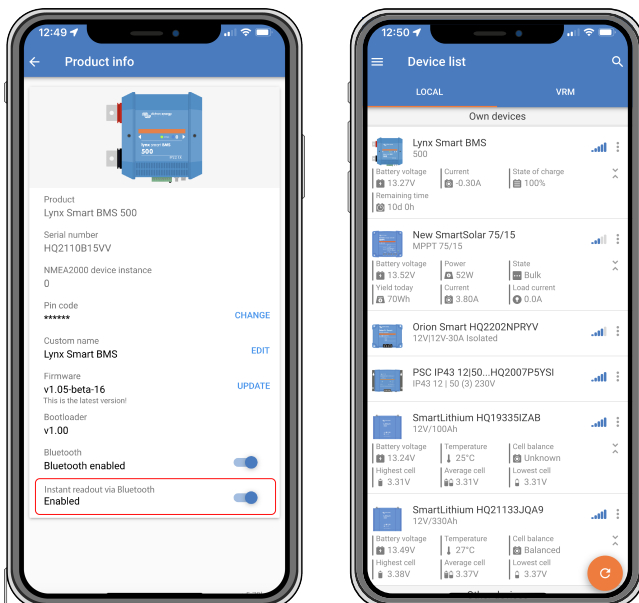

## 8. Troubleshooting and Support

Consult this chapter in case of unexpected behaviour or if you suspect a product fault.

The correct troubleshooting and support process is to first consult the common issues as described in this chapter and the [Appendix section 10.1. LED indications, warnings, alarm and error codes \[31\]](#).

Should this fail to resolve the issue, contact the point of purchase for technical support. If the point of purchase is unknown, refer to the [Victron Energy Support webpage](#).

### 8.1. How to recover from OFF mode when no charge voltage was detected

This chapter explains how to turn on the BMS (thereby activating the system again) after the BMS has switched to OFF mode when no charge voltage has been detected for 2 hours after a low cell voltage event.

#### Background:

If, after a low cell voltage event, the BMS does not detect a charge voltage within 2 hours, the BMS will enter OFF mode. In OFF mode, the ATC and ATD contacts are open and all interfaces except Bluetooth are turned off to conserve energy. When the ATC and ATD contacts open, all chargers and loads turn off. If, at a later stage, the chargers in the system are powered by the grid or a generator, they still will remain off, because the BMS is not generating the ATC signal.

#### There are two ways to make the BMS leave the OFF state so that the system will power up:

- Connect an external charger to the system. The BMS will resume normal operation and close the contactor, when it detects a charge voltage on the system side of the BMS.
- Use the Remote on/off switch or the soft switch in the VictronConnect app as described in [Force the BMS out of OFF mode](#) down below.

#### Force the BMS out of OFF mode:

To force the BMS to out of OFF mode, switch the BMS Remote on/off switch or the soft switch in the VictronConnect app off for 5 seconds and then switch it back on or unplug the 11-pin multi connector from its socket and reinsert it after 5 seconds.

The BMS will activate and close its contactor so that the battery is again connected to the system, even though the battery voltage might be too low. The BMS will close the ATC and ATD contacts, providing that the battery allows this. However, in case of an empty battery, the ATD contact will stay open and only the ATC contact will close.

As soon as the ATC contact is closed, the chargers in the system will reactivate and start to charge the battery.

Once the battery is sufficiently charged, the ATD contact will close and the loads will reactivate.



Please note that the above procedure is not required when DVCC controlled chargers are present in the system. They will charge for a few minutes or MPPT chargers will stay on regardless of whether the GX device and/or ATC status is off.

### 8.2. Lynx Smart BMS does not power up

This can be caused by one of the following reasons:

#### No battery supply

No LEDs are illuminated on the Lynx Smart BMS. Check the battery supply voltage into the Lynx Smart BMS. Check cables and fuses on the battery side. It could also be that the Lynx Smart BMS is in OFF mode. For more info on that see paragraph [Powering up \[29\] \[18\]](#).

#### Reverse battery supply

Check the polarity of the supply voltage into the Lynx Smart BMS. If reverse polarity, correct polarity mistake. Unit should now power up.

#### No charging current detected for 2 hours after a low cell voltage or low temperature event

Make sure that a charger is connected and switched on. Ensure that the battery temperature is above the set threshold (default 5°C, adjustable in battery).

#### Remote on/off switched off or wire loop missing

The Remote on/off switch must be turned on or a wire loop must be inserted between pin 10 and pin 11 of the multi connector. Check that the multi connector is correctly seated.

#### Soft Switch turned off in VictronConnect App

Switch the system to ON mode using the soft switch in the VictronConnect app.

### System in Standby mode

Switch the system to ON mode using the soft switch in the VictronConnect app or a connected GX device.

### Battery voltage issues

The Lynx Smart BMS, on first install, will auto detect the battery voltage and set to either 12V, 24V or 48V. Each set voltage has a specific battery voltage range (threshold). If the Lynx Smart BMS measures a voltage that is outside this threshold, one of these alarms will be generated:

- Probably wrong system voltage - red LED flashing 7 times every 4 seconds.
- Battery voltage not allowed - red LED flashing 14 times every 4 seconds.

To fix, check the battery settings or check the battery voltage.

This table indicates the voltage thresholds for each system voltage:

System voltage	Voltage threshold
12V	9V - 15V
24V	16V - 30V
48V	32V - 60V

### Pre-charge errors

There are two specific errors that can be generated during the pre-charge process:

- Pre-charge high current – red LED flashing 6 times every 4 seconds. The pre-charged energy or current has been exceeded.
- Pre-charge timeout – red LED flashing 5 times every 4 seconds. It has taken too long for the pre-charge process to complete.

Pre-charge faults are mostly caused by:

- A short circuit on the load output – potentially caused by a malfunctioning load or if there is a wiring issue like a short circuit.
- Loads with a too high capacitance or too low resistance (less than 20 Ohm) have been connected to the load output.

To fix these errors, turn off or remove some loads or chargers and rule out wiring problems or shorts.

### Internal error

Contact your Victron supplier if one of the following errors are occurring:

- Internal supply error - Red LED flashing 12 times every 4 seconds
- Initialization error - Red LED flashing 9 times every 4 seconds
- Contactor failure - Red LED flashing 10 times every 4 seconds
- Hardware error - GX device alarm calibration lost - GX device alarm

## 8.3. Lynx Smart BMS operational issues

### High discharge current

A high current alarm is given when the current is more than 600A for more than 5 minutes. The red LED flashing 8 times every 4 seconds. Reduce the loads connected to the Lynx Smart BMS so that the current through the Lynx Smart BMS will be below 500A.

### High charge current

A high current alarm is issued when the current exceeds 600A for more than 5 minutes. The red LED flashing 8 times every 4 seconds. Turn chargers off so that the current through the Lynx Smart BMS will be below 500A.

### Contactor (relay) issues

The Lynx Smart BMS is equipped with 3 guards to protect the contactor.

- Over current protection: an alarm is generated when the current exceeds 600A for 5 minutes.
- Contactor voltage monitoring: an alarm is generated when the voltage over the contactor is higher than 0.5V. A high voltage indicates high resistance and high power dissipation, indicating a bad contactor.
- Electrical/mechanical protection: there are 2 thermal switches mounted on the busbar. The contactor opens and an alarm is generated when the temperature of the busbars becomes higher than 130°C.

### High BMS temperature

Check ambient temperature and check if the two built-in fans are running. Reduce the ambient temperature.

#### **Settings invalid**

Settings data is corrupt. Reset to factory defaults.

## **8.4. BMS issues**

### **8.4.1. The BMS frequently disables the battery charger**

A well-balanced battery does not disable the charger, even when the batteries are fully charged. But when the BMS frequently disables the charger, this is an indication of cell imbalance.

In case of moderate or large cell imbalance it is an expected behaviour that the BMS frequently disables the battery charger. This is the mechanism behind this behaviour:

As soon as one cell reaches 3.75V, the BMS disables the charger due to high cell voltage. Whilst the charger is disabled, the cell balancing process still continues, moving energy from the highest cell into adjacent cells. The highest cell voltage drops and as soon as it falls below 3.6V, the charger is activated again. This cycling typically takes between one and three minutes. The voltage of the highest cell will rise again quickly (this can be in a matter of seconds), after which the charger will be disabled again and so forth. This does not indicate a problem with the battery or the cells and will continue with this behaviour until all cells are fully charged and balanced. This process might take several hours, depending on the level of imbalance. In case of serious imbalance this process can take up to 12 hours. Balancing will continue throughout this process and balancing even takes place when the charger is disabled. The continued enabling and disabling of the charger can appear strange, but rest assured that there is no problem. The BMS is merely protecting the cells from over voltage.

### **8.4.2. The BMS is prematurely turning loads off**

This could be because of a cell imbalance.

If a cell voltage falls below the "Allowed-to-Discharge cell voltage" setting in the battery (default 2.8V), the BMS will turn the loads off.

Check the cell voltages of all batteries that are connected to the BMS using the VictronConnect app. Also check if all batteries have the same "Allowed-to-Discharge cell voltage" settings.

Once the loads have been turned off due to low cell voltage, the cell voltage of all cells needs to be 3.2V or higher before the BMS will turn the loads back on.

### **8.4.3. The pre-alarm setting is missing in VictronConnect**

Pre-alarm is only available if the battery supports it. The current battery models all support it, but older batteries do not have the hardware required for the pre-alarm feature.

### **8.4.4. BMS is displaying alarm while all cell voltages are within range**

A possible cause is a loose or damaged BMS cable or connector. Check all BMS cables and their connections.

Also consider that once there has been a cell under voltage alarm, the cell voltage of all cells need to be increased to 3.2V before the battery clears the under voltage alarm.

A way to rule out if a fault is originating from a faulty BMS or from a faulty battery is to check the BMS using one of the following BMS test procedures:

#### **Single battery and BMS check:**

- Disconnect both BMS cables from the BMS.
- Connect a single BMS extension cable between both BMS cable connectors. The BMS cable should be connected in a loop, as in below diagram. The loop tricks the BMS in thinking that there is a battery connected without any alarms.
- If the alarm is still active after the loop has been placed, the BMS is faulty.
- If the BMS cleared the alarm after the loop has been placed, the battery is faulty and not the BMS.

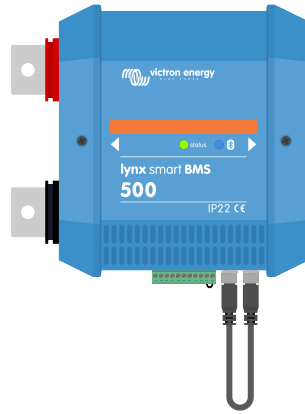

Testing a Lynx Smart BMS by connecting a single BMS extension cable to both BMS cable connections

**Multiple batteries and BMS check:**

- Bypass one of the batteries by disconnecting both its BMS cables.
- Connect the BMS cables of the neighbouring batteries (or battery and BMS) to each other, effectively bypassing the battery.
- Check if the BMS has cleared its alarm.
- If the alarm has not been cleared, repeat this for the next battery.
- If the alarm is still active after all batteries have been bypassed, the BMS is faulty.
- If the BMS cleared its alarm when a particular battery was bypassed, that particular battery is faulty.

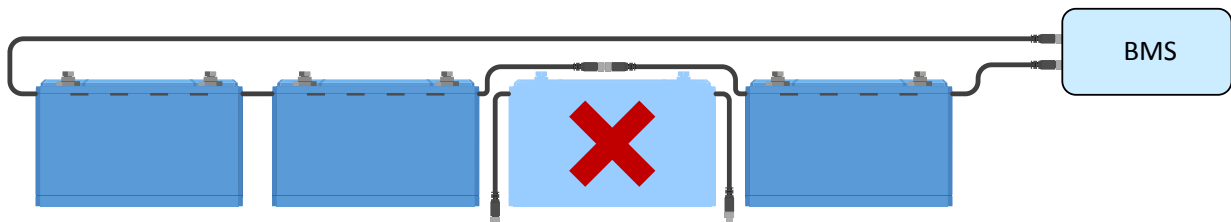

Eliminating a BMS error by bypassing a suspect battery

**8.4.5. How to test if the BMS is functional**

To test if the BMS is functional, disconnect one of the battery BMS cables and see if the BMS will go into alarm mode.

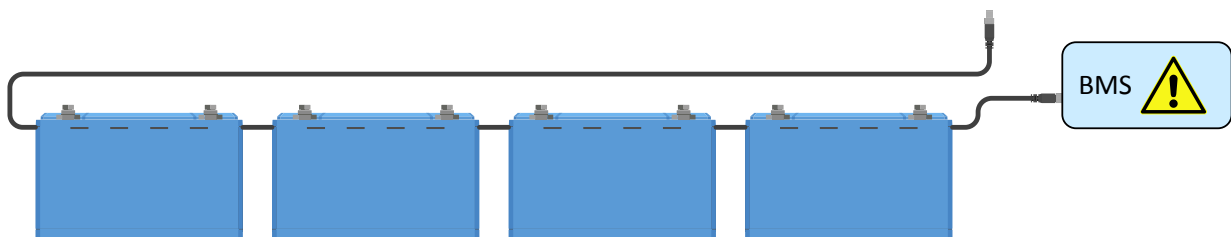

Check BMS functionality by deliberately loosening a BMS cable

**8.4.6. System in OFF mode**

This is indicated by the status LED off and the Bluetooth LED flashing every 3 seconds.

The Lynx Smart BMS goes into OFF mode once a low cell voltage event occurred and no charge voltage has been detected for 2 hours to conserve as much power as possible. Bluetooth is still active, but other non-essential interfaces are turned off, including the power to the Lynx Distributor(s).

Check the cell voltages of the connected batteries and if they are low, charge the batteries. As soon as the Lynx Smart BMS sees a charge voltage, it will automatically reactivate and close its contactor to allow for battery charging.

### 8.4.7. ATC/ATD is missing

Error #36 (ATC/ATD error) occurs when discharge current > 1.5A while ATD is disabled or when charge current > 1A while ATC is disabled.

This can be caused by loads or chargers that are not controlled by ATC/ATD.

Make sure all loads and chargers are controlled by ATC/ATD (if not controlled by DVCC).

## 8.5. Battery monitor issues

### 8.5.1. Incomplete current reading

The negatives of all loads and charge sources in the system must be connected to the system minus side of the shunt, which is the right side of the BMS in normal position.

If the negative terminal of a load or charging source is connected directly to the battery negative terminal or the "battery negative" side of the shunt, its current will not flow through the battery monitor. It will therefore not be taken into account and results in a wrong SoC reading.

### 8.5.2. Incorrect state of charge reading

An incorrect state of charge can be caused by a variety of reasons.

#### Incorrect battery settings

The following parameter(s) will have an effect on the state of charge calculations if they have been set up incorrectly:

- Battery capacity

Double check via VictronConnect app that the Battery capacity settings of the Lynx Smart BMS is correct.

#### Incorrect state of charge due to a synchronisation issue:

The synchronisation process is automatic and is performed each time the battery is fully charged. The battery monitor determines that the battery is fully charged when all 3 "charged" conditions have been met. The "charged" conditions are:

- Charged voltage (Voltage)
- Tail current (% of battery capacity)
- Charge detection time (minutes)

Practical example (default battery monitor settings and a 12.8V 200Ah lithium battery) for the conditions that must be met before synchronisation takes place:

- The battery voltage has to be above 14.0V.
- The charge current has to be less than  $0.04 \times \text{battery capacity (Ah)}$ . For a 200Ah battery this is  $0.04 \times 200 = 8\text{A}$
- Both above conditions have to be stable for 3 minutes

If the battery is not fully charged or if the automatic synchronisation does not happen, the state of charge value will start to drift and will eventually not represent the actual state of charge of the battery.

The SoC can also be synchronised and set manually via the VictronConnect app (requires VictronConnect v5.70 or later).

### 8.5.3. State of charge does not increase/decrease fast enough or too fast when charging/ discharging.

This can happen when the battery monitor thinks the battery is bigger or smaller than in reality. Check if the battery capacity has been set correctly.

### 8.5.4. Synchronisation issues

If the battery monitor does not synchronise automatically, one possibility could be that the battery never reaches a fully charged state. Fully charge the battery and see if the state of charge eventually indicates 100%.

Another possibility is that the Charged voltage setting should be lowered and/or the Tail current setting should be increased.

It is also possible that the battery monitor synchronises too early. This can happen in solar systems or in systems that have fluctuating charge currents. If this is the case, try to decrease the Charged voltage, Tail Current and Charged detection time settings slightly.

## 8.6. VictronConnect issues

### Interrupted firmware update

This is recoverable. Just try to update the firmware again.

## 8.7. GX device issues

This chapter only describes the most common issues. If this chapter does not solve your issue, consult the manual of the GX device.

### Incorrect CAN-bus profile selected

Check that VE.Can is set to use the correct CAN-bus profile. On your GX device navigate to Settings/Services/VE.Can port and check if it is set to "VE.Can & Lynx Ion BMS (250kbit/s)".

Also make sure that the Lynx Smart BMS is connected to the VE.Can port of your GX device and not the BMS-Can port (e. g. on a Cerbo GX).

### RJ45 terminator or cable issue

VE.Can devices connect in "daisy chain" to each other and a [RJ45 terminator](#) needs to be used with the first and last device in the chain.

When connecting VE.Can devices, always use "manufactured" [RJ45 UTP cables](#). Do not manufacture these cables yourself. Many communication and other seemingly unrelated product issues are caused by faulty home made cables.

## 9. Warranty

This product has a 5-year limited warranty. This limited warranty covers defects in materials and workmanship in this product and lasts for five years from the date of original purchase of this product. To claim warranty the customer must return the product together with the receipt of purchase to the point of purchase. This limited warranty does not cover damage, deterioration or malfunction resulting from alteration, modification, improper or unreasonable use or misuse, neglect, exposure to excess moisture, fire, improper packing, lightning, power surges, or other acts of nature. This limited warranty does not cover damage, deterioration or malfunction resulting from repairs attempted by anyone unauthorized by Victron Energy to make such repairs. Non-compliance with the instructions in this manual will render the warranty void. Victron Energy is not liable for any consequential damages arising from the use of this product. The maximum liability of Victron Energy under this limited warranty shall not exceed the actual purchase price of the product.



## 10. Technical specifications

Power	
Supply voltage range	9 – 58Vdc
Supported system voltages	12, 24 or 48V
Reverse polarity protection	No
Main safety contactor continuous current rating	500A continuous
Main safety contactor peak current rating	600A for 5 minutes
Power consumption OFF mode	0.50mA for all system voltages
Power consumption in Standby mode	Approximately 0.6W ( 50mA at 12V)
Power consumption in ON mode	Approximately 2.6W (217mA at 12V) depending on the state of the relays
Minimum load resistance for pre-charging	10Ω and above for 12V systems 20Ω and above for 24V and 48V systems
AUX output maximum current rating	1.1A continuous, protected by resettable fuse
Allow-to-charge port maximum current rating	0.5A at 60Vdc, protected by resettable fuse
Allow-to-discharge port maximum current rating	0.5A at 60Vdc, protected by resettable fuse
Programmable relay (SPDT) maximum current rating	2A at 60Vdc

Connections	
Busbar	M8
VE.Can	RJ45 and RJ45 terminator
I/O	Screw terminals
Battery BMS cables	Male and female circular 3-pole connector with M8 screw ring. Up to 26 batteries can be connected to the BMS by daisy chaining them
Lynx Distributor (up to 4 modules)	RJ10 (cable ships with each Lynx Distributor)

Physical	
Enclosure material	ABS
Enclosure dimensions (h x w x d)	190 x 180 x 80mm
Unit weight	1.9 kg
Busbar material	Tinned copper
Busbar dimensions (h x w)	8 x 30mm

Environmental	
Operating temperature range	-40°C to +60°
Storage temperature range	-40°C to +60°
Humidity	Max. 95% (non-condensing)
Protection class	IP22

## 11. Appendix

### 11.1. LED indications, warnings, alarm and error codes

#### LEDs

The Lynx Smart BMS is equipped with two LEDs, the Bluetooth LED and the Status LED. These LEDs will indicate the operation mode and the fault mode in case there is a fault.

Bluetooth LED	Description
Off	No system power or Bluetooth disabled in VictronConnect app. Bluetooth can be disabled in both, VictronConnect and a GX device, but only enabled from a GX device.
Blue on	A Bluetooth device is connected to the Lynx Smart BMS
Blue flashing	Bluetooth is active but no device is connected
Blue flashing at 3 seconds interval	The Lynx Smart BMS is in OFF mode but is still accessible over Bluetooth

Status LED	Description
Off	The Lynx Smart BMS is in OFF mode
Orange on	Initializing or shutdown
Orange blinking	Delayed shutdown due to cooling down the pre-charge circuit
Green on	Running, the contactor is closed
Green blinking	Pre-charging
Green flashing at 3 seconds interval	The Lynx Smart BMS is in Standby mode
Green and red alternating	System in bootloader mode (updating firmware)
Red flashing 1 time every 4 seconds	Warning, see VictronConnect for more information
Red flashing 2 times every 4 seconds	Battery communication error, check battery BMS cables
Red flashing 3 times every 4 seconds	High/low cell voltage or high/low temperature detected
Red flashing 4 times every 4 seconds	High BMS temperature detected
Red flashing 5 times every 4 seconds	Pre-charge time out
Red flashing 6 times every 4 seconds	Pre-charge high current
Red flashing 7 times every 4 seconds	Probably wrong system voltage
Red flashing 8 times every 4 seconds	Contactor current too high
Red flashing 9 times every 4 seconds	Initialization error
Red flashing 10 times every 4 seconds	Safety contactor failure
Red flashing 12 times every 4 seconds	Internal supply error
Red flashing 14 times every 4 seconds	Battery voltage not allowed

#### Warning, alarm and error codes

Warning, alarm and error codes are also reported via the VictronConnect app or a connected GX device and VRM.

A warning indicates a problem that, if not corrected, will result in a system shutdown, while an alarm indicates the reason for the system shutdown.

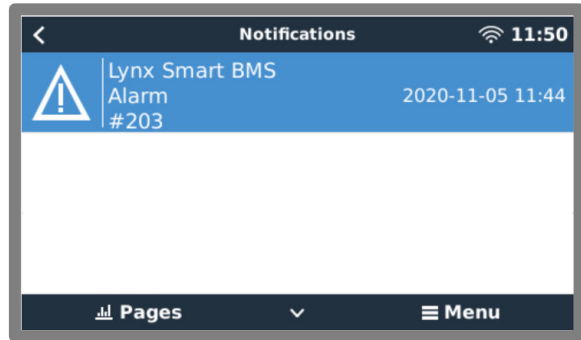
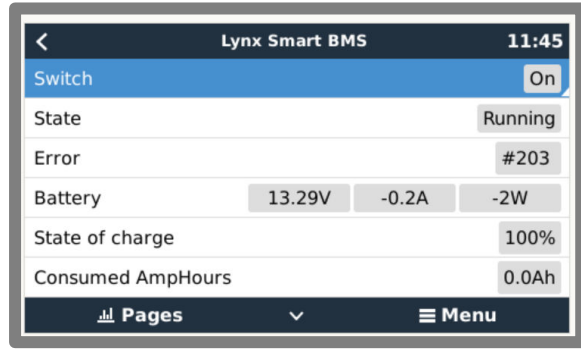
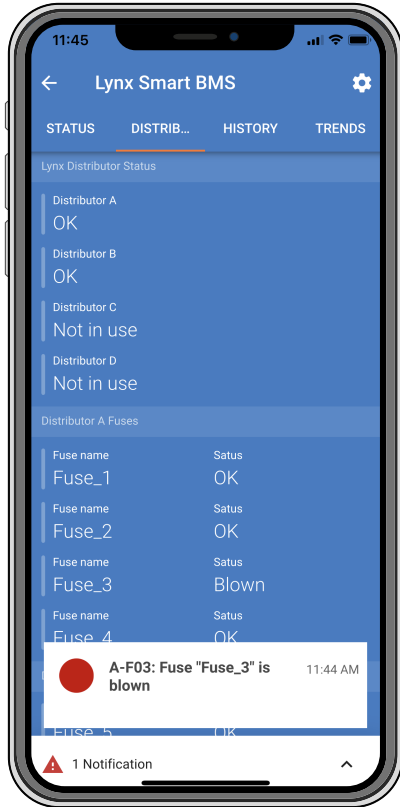

Lynx Smart BMS alarms on the VictronConnect App and a GX device

The following tables list all warning, alarm and error codes:

**Warning codes**

VictronConnect warning code	GX device warning code	Message	Instructions / remarks
W-B01	Low cell voltage	Low cell voltage	Charge the battery or reduce the load to prevent an imminent system shutdown.
W-B02	#105 or #106	High current	Reduce the current to prevent an imminent system shutdown. Do this by reducing the load or by turning loads off.
W-B03	#101	High BMS temperature	Check the ambient temperature and check if the BMS fans are running. If the fans are running, reduce the ambient temperature. If the fans are not running, contact your Victron dealer.
W-B04	#112	Warning bad contactor	Reduce the current to prevent an imminent system shutdown. Do this by reducing the load or by turning loads off. Contact your Victron dealer.
W-B06	-	Load will disconnect	The loads will be turned off in 30 seconds if fault is not resolved. For example low battery voltage. This warning is always in combined the reason why the load will disconnect. The loads are turned off via the ATD contact and/or via the GX device.
W-B07	-	Low SoC	Charge battery or reduce load to prevent imminent system shutdown.
W-D01	#221	Communication with distributor A lost	Check the cable between BMS and Distributor.
W-D02	#222	Communication with distributor B lost	Check the cable between BMS and Distributor.

VictronConnect warning code	GX device warning code	Message	Instructions / remarks
W-D03	#223	Communication with distributor C lost	Check the cable between BMS and Distributor.
W-D04	#224	Communication with distributor D lost	Check the cable between BMS and Distributor.

#### Alarm codes

VictronConnect alarm code	GX device alarm code	Message	Instructions / remarks
A-B01	#103	Low cell voltage	Charge battery. The system will turn the loads back on when the battery is sufficiently charged.
A-B02	#105 or #106	High current	Reduce charging current or turn off some loads. The system will try to re-enable chargers or loads in 5 minutes.
A-B06	-	Load disconnected	The loads have been turned off via the ATD contact and/or via the GX device. Resolve this alarm by charging the battery. If not resolved, eventually the contactor will open and the DC system will be disconnected.
A-B07	-	Low SoC	Charge battery. The system will turn the loads back on when the battery is sufficiently charged.

#### Error codes

VictronConnect error code	GX device error code	Message	Instructions / remarks
E-B09	#09	Battery voltage not allowed	The battery voltage is too high or too low. Check the battery voltage and check the battery settings in the VictronConnect app. This error occurs when the battery voltage is outside all system voltage ranges ( $9V > V_{bat} > 60V$ )
E-B11	#11	Hardware error	Contact your Victron dealer.
E-B25	#25	Pre-charge error	The load resistance is too low to pre-charge the loads. Disconnect or reduce some DC loads.
E-B26	#26	Contactor error	Contact your Victron dealer.
E-B34	#34	Wrong system voltage	Check battery voltage settings in the VictronConnect app.
E-B35	#35	Pre-charge timeout	The load capacity is too high to pre-charge. Disconnect some DC loads.
E-B36	#36	ATC/ATD failure	Check ATC/ATD wiring and make sure that all loads and chargers are controlled by ATC or ATD.
E-B119	#119	Settings data lost	Settings data is corrupt. Go to the settings page and reset to defaults.

#### Alarm codes Lynx Distributor related

VictronConnect alarm code	GX device alarm code	Message	Instruction / remarks
A-F01	#201	Fuse "Fuse_1" is blown	Fuse is blown. Replace fuse.
A-F02	#202	Fuse "Fuse_2" is blown	
A-F03	#203	Fuse "Fuse_3" is blown	
A-F04	#204	Fuse "Fuse_4" is blown	
A-F05	#205	Fuse "Fuse_5" is blown	
A-F06	#206	Fuse "Fuse_6" is blown	
A-F07	#207	Fuse "Fuse_7" is blown	
A-F08	#208	Fuse "Fuse_8" is blown	
A-F09	#209	Fuse "Fuse_9" is blown	
A-F10	#210	Fuse "Fuse_10" is blown	
A-F11	#211	Fuse "Fuse_11" is blown	
A-F12	#212	Fuse "Fuse_12" is blown	
A-F13	#213	Fuse "Fuse_13" is blown	
A-F14	#214	Fuse "Fuse_14" is blown	
A-F15	#215	Fuse "Fuse_15" is blown	
A-F16	#216	Fuse "Fuse_16" is blown	

## 11.2. Supported NMEA 2000 PGNs

Description	PGN
Product Information	126996
DC detailed Status	127506
DC/Battery Status	127508
Switch Bank Status	127501
<ul style="list-style-type: none"> <li>Status 1: Contactor</li> <li>Status 2: Alarm</li> <li>Status 3: Battery voltage low</li> <li>Status 4: Battery voltage high</li> <li>Status 5: Programmable relay status</li> </ul>	

Class and function:

- N2K device class: Electrical generation
- N2K device function: Battery

For more information see the [NMEA2000 & MFD integration guide](#).

## 11.3. List of battery monitor settings

Description	default value	adjustable	fixed	automatic
Battery capacity	200Ah	Yes	No	No
Charged voltage	14.0V/28.0V/56.0V*	Yes	No	No
Tail current	4%	Yes	No	No
Zero current calibration	---	No	No	Yes (at power up)
Peukert exponent	1.05	No	Yes	No

Description	default value	adjustable	fixed	automatic
Charge efficiency factor	99%	No	Yes	No
Current threshold	0.05A	No	Yes	No
Low SoC warning level	15%	Yes	No	No
Discharge floor	10%	Yes	No	No
Delta T	1	No	Yes	No
SoC Cycle end	90%	No	Yes	No
SoC Cycle	65%	No	Yes	No
SoC full discharge	5%	No	Yes	No

\* for a 12V/24V/48V system

## 11.4. Multi connector pin-out and overview

Pin	Name	Type	Function
1	AUX voltage output +	System voltage positive	The positive connection to power auxiliary devices, like a GX device.
2	AUX voltage output -	System voltage negative	The negative (ground) connection to power auxiliary devices, like a GX device.
3	Allow to charge	Potential free contact	Turns chargers on or off via a wired signal. Pin 3 can be used as the signal input for pin 4 and wired e. g. from AUX + or AUX -. See system examples for correct wiring.  When charging is allowed, the contacts are closed and when not allowed, the contacts are open.
4			
5	Allow to discharge	Potential free contact	Turns loads on or off via a wired signal. Pin 5 can be used as the signal input for pin 6 and wired e. g. from AUX + or AUX -. See system examples for correct wiring.  When discharging is allowed, the contacts are closed and when not allowed, the contacts are open.
6			
7	Programmable relay NC	Potential free contact	The programmable relay is used to either control an alternator or as an alarm relay. For details see chapter <a href="#">Programmable relay wiring [10]</a> .
8	Programmable relay COM	Potential free contact	
9	Programmable relay NO	Potential free contact	
10	Remote on/off H	Pull-up resistor	To remotely turn the Lynx Smart BMS on or off. For full functionality see chapter <a href="#">Wiring a Remote on/off switch [10]</a> .
11	Remote on/off L	Pull-down resistor	

## 11.5. Lynx Smart BMS related menu structure of the GX device

This is an overview of the Lynx Smart BMS related menu structure of the GX device. To see all menu items shown here, Venus OS v2.90 or later is required.

Menu item	Default value / unit	Description and / or possible values
<b>Lynx Smart BMS</b>		Shows SoC, voltage and current in the device list
Switch	On	Soft switch to manually switch the Lynx Smart BMS to Standby or On mode
State	Running	Possible states: Initialising, Pre-charging, Running, Shutdown, Standby

Menu item	Default value / unit	Description and / or possible values
Error	#0 - No error	Error state
Battery	Voltage, current, power	Shows current battery monitor data
State of charge	%	State of charge in percent
Consumed AmpHours	Ah	Displays the consumed AH since the battery was last fully charged
Time-to-go	Days / Hours	Displays the estimated time, based on the current load and discharge floor setting
<b>Alarms</b>		
High internal temperature	Ok	
Low cell voltage	Ok	
Low SoC	Ok	
<b>History</b>		
Deepest discharge	Ah	The deepest discharge since last history reset
Total charge cycles	0	Number of charge cycles since last history reset
Number of full discharges	0	A full discharge is accounted for after SoC falls below 5%
Cumulative Ah drawn	Ah	Cumulative Ah drawn since last history reset
Minimum voltage	V	Minimum voltage since last history reset
Maximum voltage	V	Maximum voltage since last history reset
Synchronisation count	0	Cumulative number of battery monitor synchronisations
Discharged energy	kWh	Cumulative number of discharged energy since last history reset
Charged energy	kWh	Cumulative number of charged energy since last history reset
Clear history	Press to clear	Clears all history data
<b>Diagnostics</b>		
Diagnostics		Shows last known errors
<b>Fuses</b>		
Distributor A	Ok	Possible states: Ok, Fuse blown
Fuse 1..4	Ok	Possible states: Ok, Not used, Blown
Distributor B	Ok	Possible states: Ok, Fuse blown
Fuses 1..4	Ok	Possible states: Ok, Not used, Blown
<b>IO</b>		
System switch	Enabled	Status of the system switch
Allow to charge	Yes	Status of the ATC signal
Allow to discharge	Yes	Status of the ATD signal
<b>Device</b>		
Device related parameters and custom name setting		
<b>Parameters</b>		
Charge Voltage Limit (CVL)	V	Shows the voltage target send to DVCC compatible chargers (for a 12V battery: 13.50V or 14.20V)
Charge Current Limit (CCL)	A	Maximum allowed charge current limit send to DVCC compatible chargers
Discharge Current Limit (DCL)	A	Maximum allowed discharge current limit

## 11.6. Enclosure dimensions

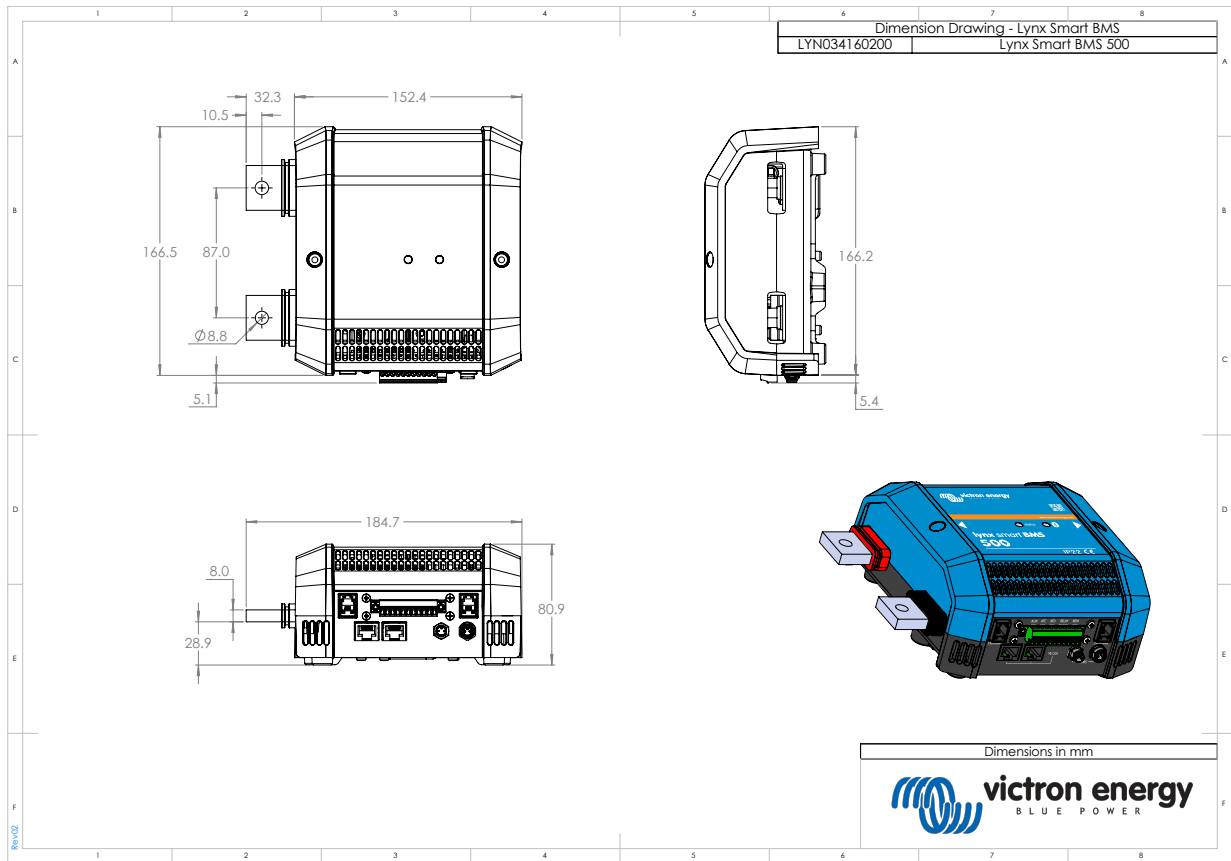

Lynx Smart BMS enclosure dimensions