

VERSION HISTORY	NOTES
#	DATE
5.01	08-SEP-16
	ORIGINAL



THIRD ANGLE PROJECTION

TITLE  
**MOTOR INSERTS**  
SHEET  
**OVERVIEW**  
FIASCOCASES.COM

DATE  
**08-SEP-16**  
DESIGNED  
**MARTIN KAUBITZSCH**  
PROJECT MANAGER  
**JOE BRADFORD**

SCALE | 1:10  
PAPER | A4  
FILE | MOTOR INSERTS A4.dwg  
PLOT | 03/11/2020 01:29 PM  
SHEET | 1 OF 1

VERSION



OUTPUT CHAIN FLOW-PATH OPTIMISED FOR EASY CHAIN RUN-THROUGH

CHAIN HOOK HANGS ON DIVIDER - CAPTURED WHEN LID CLOSED

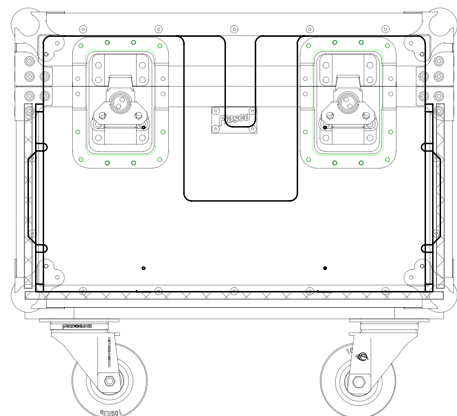

600 MOTOR INSERT INSTALLED IN 600 SHORT CASE

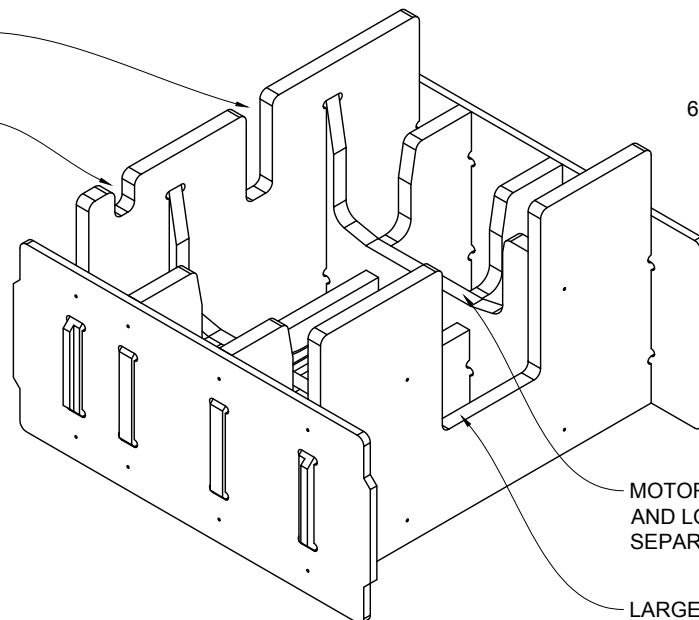

600 MOTOR INSERT

MOTOR FULLY SUPPORTED AND LOOSE CHAIN SEPARATED

LARGE DIVIDER OPENING ALLOWS CHAIN BAG TO REMAIN RIGGED TO MOTOR

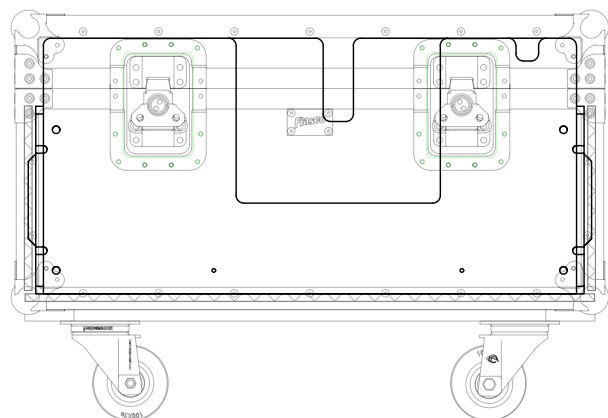

800 MOTOR INSERT INSTALLED IN 800 SHORT CASE

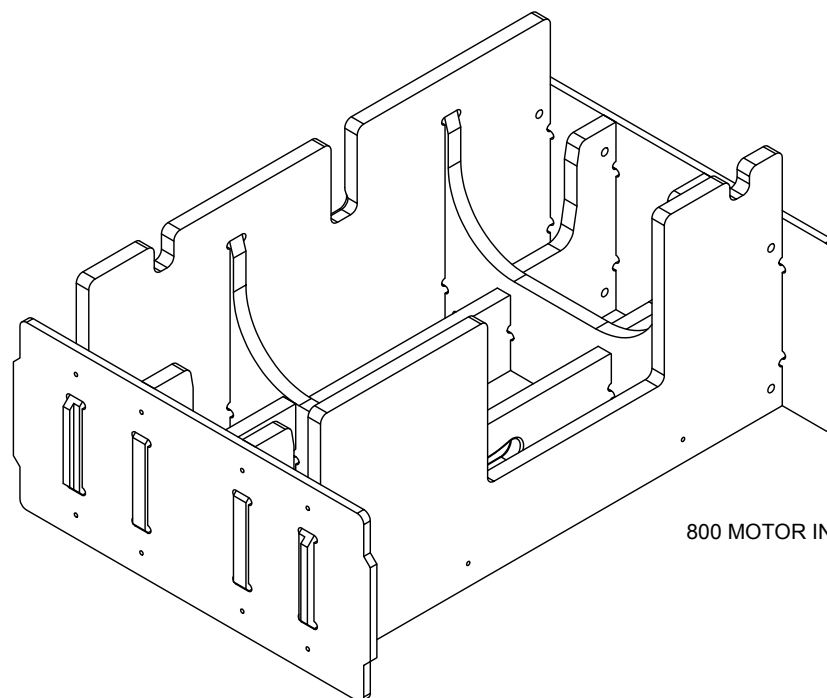

800 MOTOR INSERT