

↑ EXTERNAL VIEW ↑
↓ INTERNAL VIEW ↓

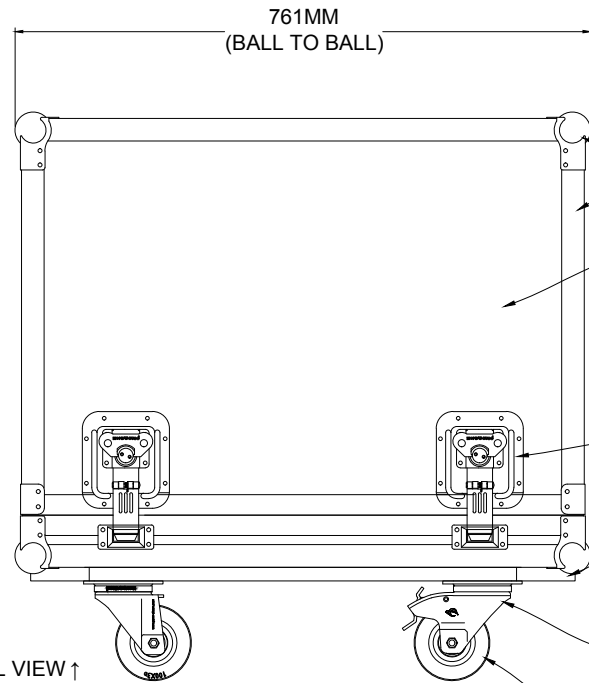

penn-celcom EXTRUSION & ZINC PLATED HARDWARE

ULTRA LIGHTWEIGHT HONEYCOMB STRUCTURED POLYPROPYLENE FLIGHT PANEL
40% LIGHTER THAN PLYWOOD

FLIP OVER LATCHES MAKE THE LID IDEAL FOR STACKING

18MM PLY WHEEL-BOARD WITH FINGER CUT-OUTS FOR LOW LIFTING

TWO BRAKED WHEELS

penn-celcom
250KG BLUE WHEELS

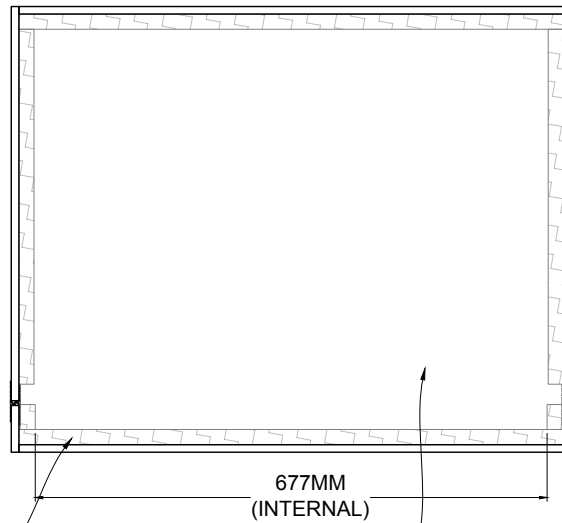
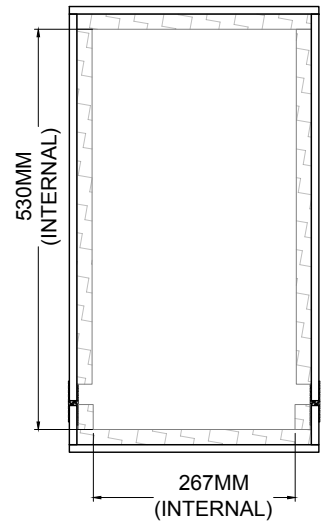

DURABLE SOFT FOAM LINING

INTERNAL CAPACITY: 87L
SHIPPING VOLUME: 0.20M³

LOW PROFILE BASE DOES NOT INTERFERE WITH SPEAKER OUTPUT

#	DATE	NOTES
4.5	25-OCT-14	ORIGINAL
4.51	9-JUN-15	CHANGED FOAM TO XPE AND UPDATED TO V4.51
4.6	26-SEP-15	REDESIGNED WITH HONEYCOMB STRUCTURED POLYPROPYLENE FLIGHT PANEL HARDWARE CUT-OUTS. CHANGED WHEELBOARD FOR STACKING.
5.0	12-OCT-18	CHANGED FOAM TO EVA, 10MM HONEYCOMB STRUCTURE AND NEW WHEELBOARD

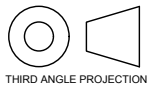

TITLE
FENDER TWIN CASE

SHEET
OVERVIEW

FIASCOCASES.COM

DATE
12-OCT-2018

DESIGNED
ASH ALGIE

PROJECT MANAGER
JOE BRADFORD

SCALE | 1:10
PAPER | A4
FILE | FENDER-TWIN CASE V5.0.dwg
PLOT | 03/10/2019 12:22 PM
SHEET | 1 OF 1

VERSION

