

↑ EXTERNAL VIEW ↑
↓ INTERNAL VIEW ↓

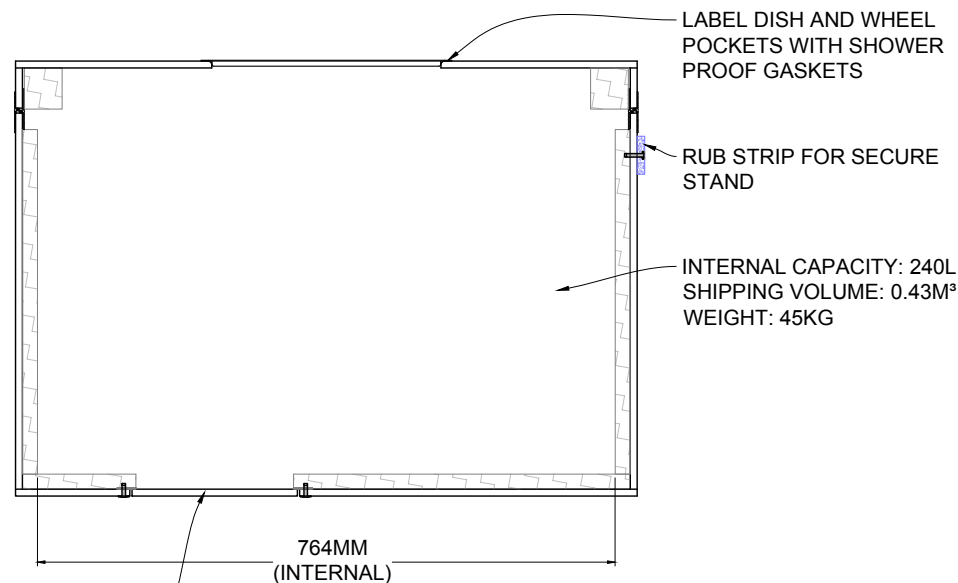

HATCH FOR EASY ACCESS
TO INPUTS ON BACK SIDE

VERSION HISTORY	NOTES
#	DATE
4.6	10-DEC-15 ORIGINAL
5.0	10-AUG-18 UPDATE TO V5.0 STANDARDS

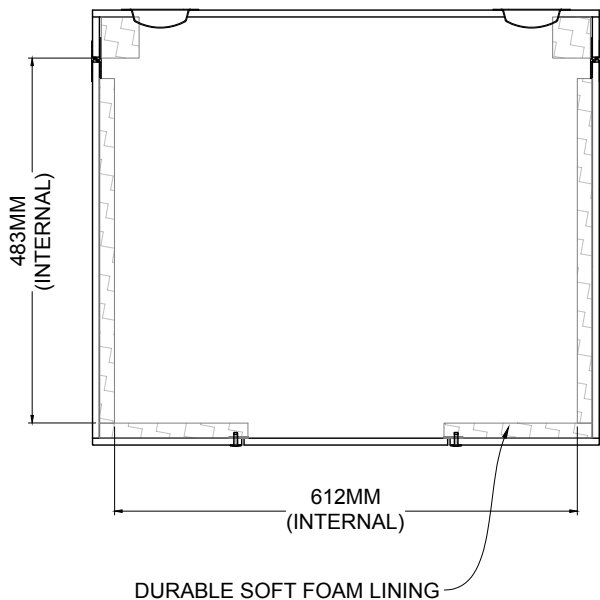

TITLE
AMPEG SVT-410HLF

SHEET
OVERVIEW

FIASCOCASES.COM

DATE
10-AUG-18

DESIGNED
MATT WATERHOUSE

PROJECT MANAGER
JOE BRADFORD

SCALE | 1:10
PAPER | A4
FILE | AMP CASE AMPEG SVT-410HLF
PLOT | 04/10/2019 11:24 AM
SHEET | 1 OF 1

VERSION

5.0