

↑ EXTERNAL VIEW ↑
↓ INTERNAL VIEW ↓

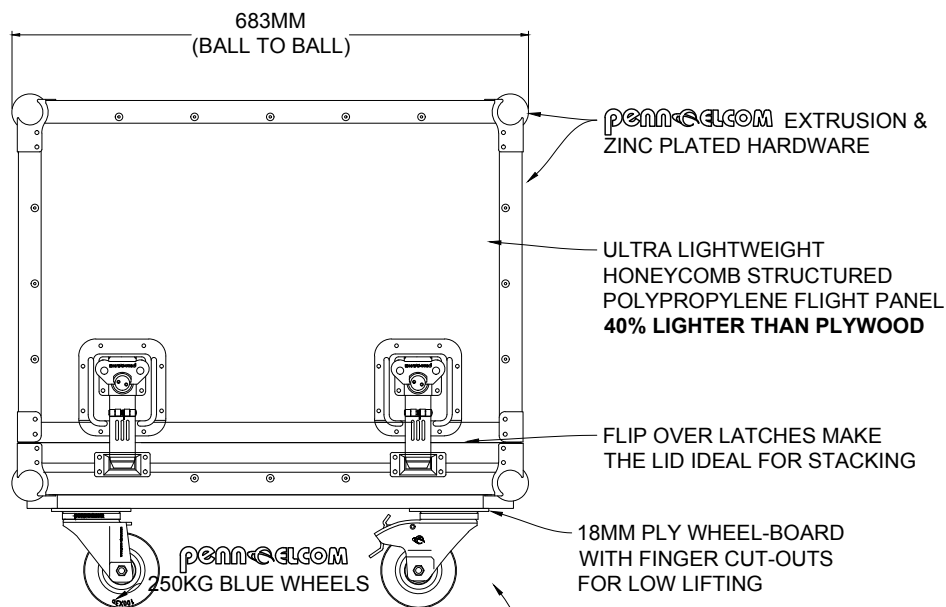

TWO BRAKED WHEELS

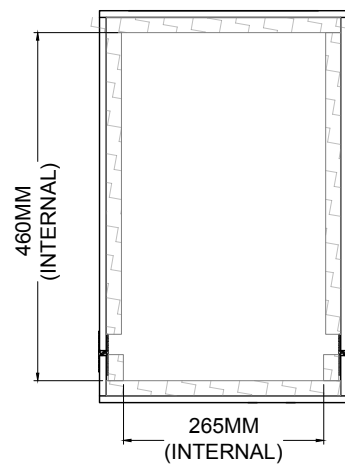

DURABLE SOFT FOAM LINING

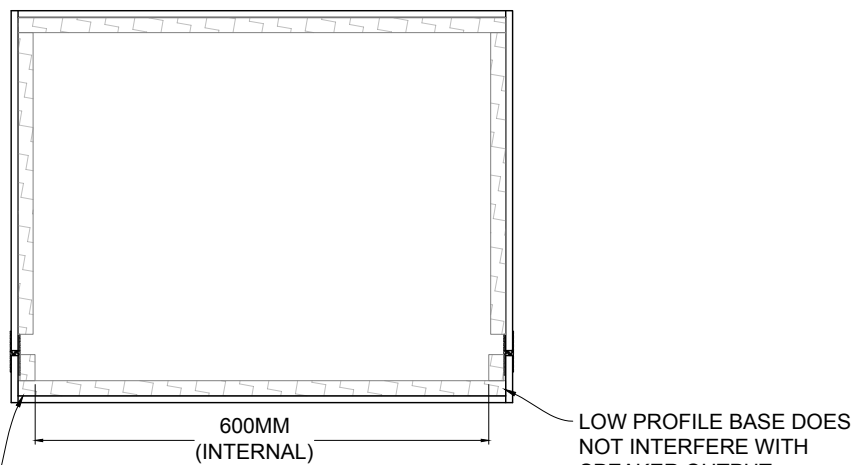

VERSION HISTORY	
#	DATE
5.00	06-FEB-18
	ORIGINAL



THIRD ANGLE PROJECTION

TITLE
AMP CASE AC15

SHEET
OVERVIEW

FIASCOCASES.COM

DATE
06-FEB-18

DESIGNED
MARTIN KAUBITZSCH

PROJECT MANAGER
JOE BRADFORD

SCALE | 1:10
PAPER | A4
FILE | AMP CASE AC15 V5.00.dwg
PLOT | 24/09/2019 03:46 PM
SHEET | 1 OF 1

VERSION

