



LET US **STEEL** YOUR HEART

1telluria



TELLURIA, let us **STEEL** your heart

We deem layout and comfort to be paramount in our homes. So why not in the garden too? It's all possible with our **TELLURIA** storage unit. Lend your garden the touch of elegance it deserves.

All photographs in this brochure may vary from the actual products

The storage unit is a win-win solution, and is a real eye-catcher to boot. The storage unit is available in different sizes. There is a choice between 3 colours (white, light-grey and anthracite).

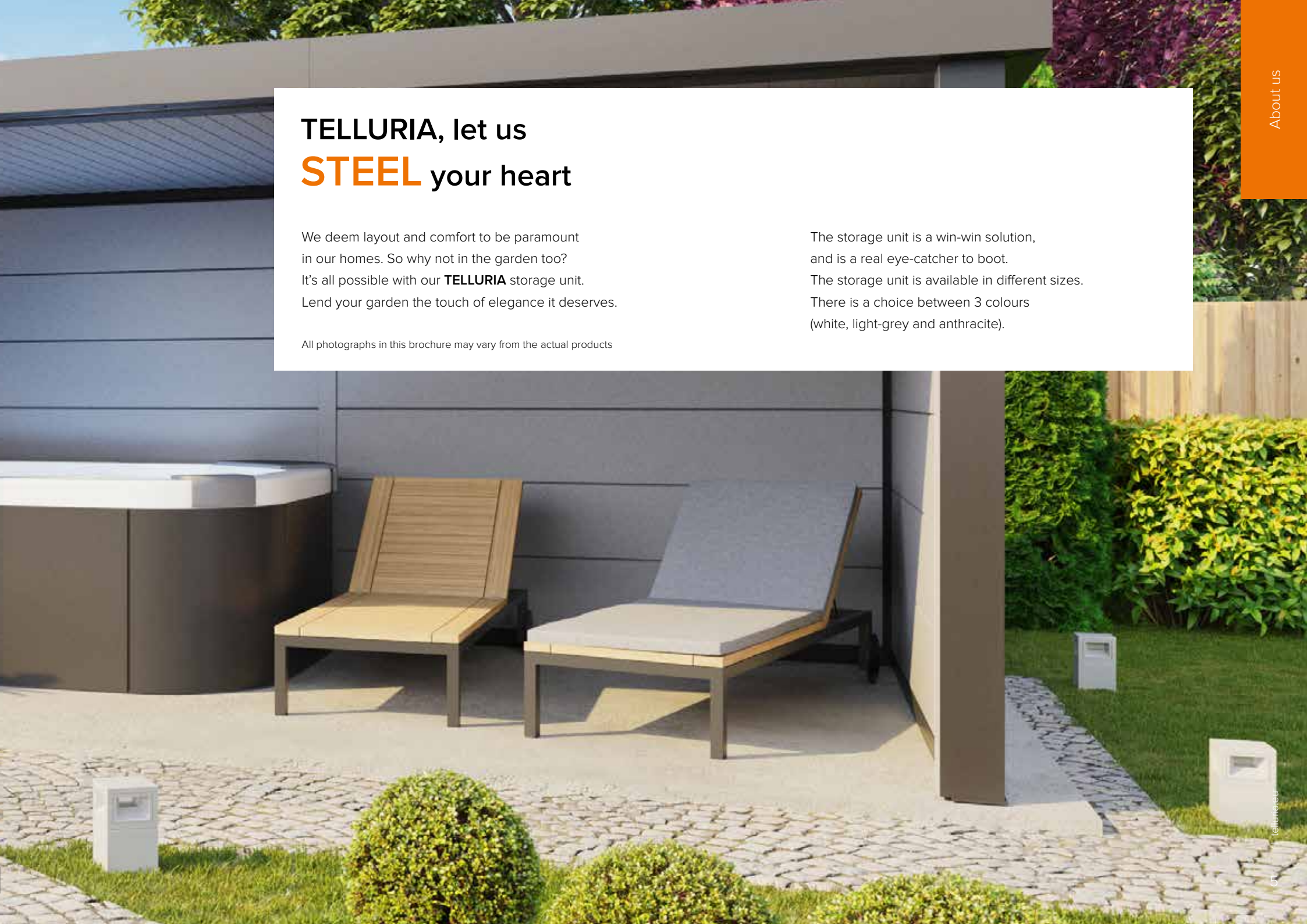

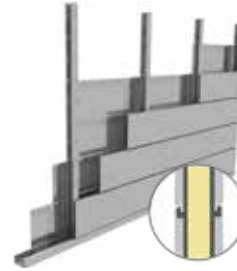

With the free space in between the inner and outer wall, insulation and utilities can be easily integrated!



STRONG AND DURABLE

The galvanised supporting structure guarantees longevity. Steel is the **material of the future**.



QUICK AND EASY ASSEMBLY

The system is made up of prefabricated components that are **easy to assemble**. Brief instruction or a concise manual is all that is needed for quick assembly.



NO MAINTENANCE

Do it the easy way with an Eleganto garden building. A steel construction requires **less maintenance than a timber one**. Touching up the paintwork is superfluous as the garden building always looks as good as new.



SECURE

Using steel means safer construction, less maintenance, fewer foundation issues and **no need for heavy construction** equipment.



CONTEMPORARY LOOK&FEEL

TELLURIA offers a range of finish options **for a contemporary, functional look&feel** that dovetails effortlessly with most building styles and settings.



ECOLOGICAL FOOTPRINT

The constructions are **100% recyclable and can be re-used**. Being lightweight in construction, Telluria can be transported very efficiently. The constructions are supplied in kit format. Accordingly, there is no waste or surplus consumption of energy, water or other resources.

Standard features:

- Door with plexi opaque glass (clear)
- Cylinder door lock
- The eaves and the door are in anthracite
- The corners are in anthracite or white
- The eaves are 10cm/15 wide
- The external sheets are made of hot-dipped galvanised steel (0.9mm)
- Roof pitch: 2°
- The roof is made up of insulated sandwich panels (4cm)
The underside of the roof is always white
- Integrated gutter with outlet
- Ventilated



Colours:

WHITE

Similar to RAL 9003

Corners also available
in white

ANTHRACITE

Similar to RAL 7043

LIGHT-GREY

Similar to RAL 7001

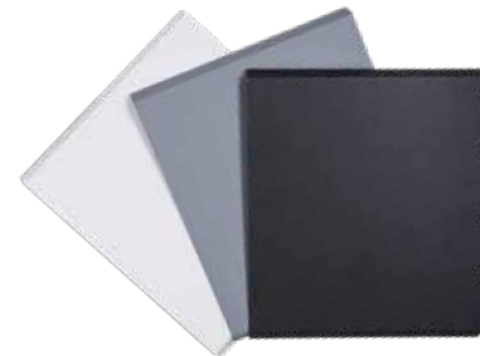

ELEGANTO

GIVE YOUR GARDEN THE ELEGANCE IT DESERVES



Eleganto 30 series

Height: 219cm.

Door opening - double door: 177x198cm.

3024: External dimensions: 298x238cm - Internal dimensions: 270x210cm.

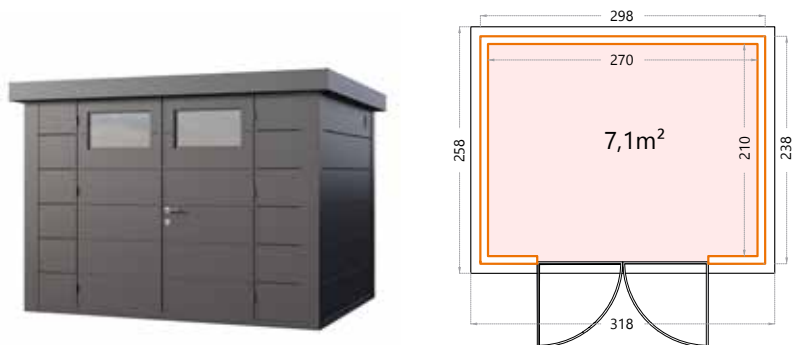

Height: 219cm.

Door opening - double door: 177x198cm.

3030: External dimensions: 298x298cm - Internal dimensions: 270x270cm.

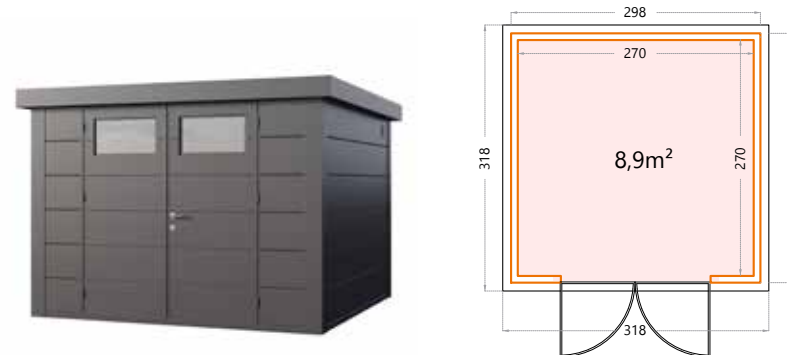

Eleganto 33 series

Height: 219cm.

Door opening - double door: 177x198cm.

3330: External dimensions: 328x298cm - Internal dimensions: 300x270cm.

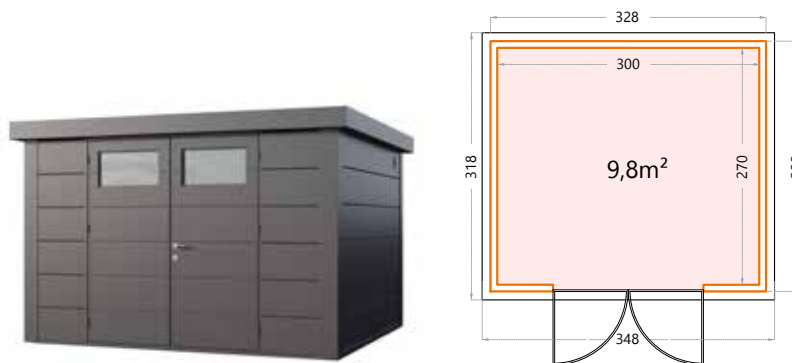

ELEGANTO PLUS

JUST THAT LITTLE BIT EXTRA



Eleganto 3930 PLUS

Height: 260cm.

Door opening - double door: 177x198cm.

3930 Plus: External dimensions: 388x298cm - Internal dimensions: 360x270cm.

Window: fixed

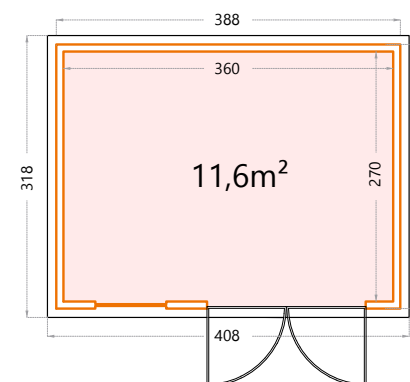

Eleganto 5436 PLUS

Height: 265cm.

Door opening - double door: 177x198cm.

5436 Plus: External dimensions: 538x358cm - Internal dimensions: 510x330cm.

Windows: tilt

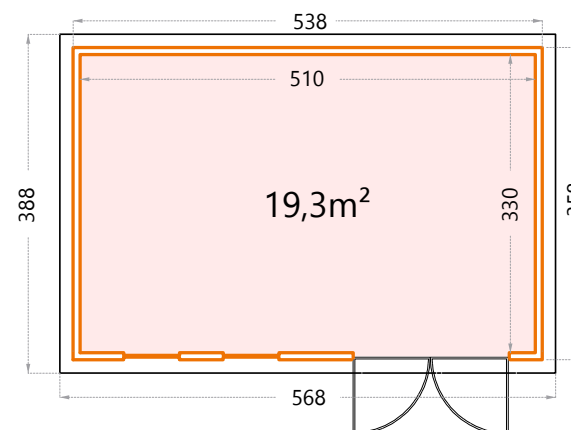

LUMINATO

CREATE YOUR UNIQUE PLACE



Luminato

Height: 219cm.

Door opening - single door: 87x198cm.

2424: External dimensions: 238x238cm - Internal dimensions: 210x210cm.

Windows: tilt

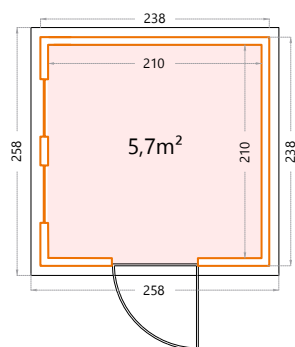

Height: 219cm.

Door opening - double door: 177x198cm.

3030: External dimensions: 298x298cm - Internal dimensions: 270x270cm.

Windows: tilt

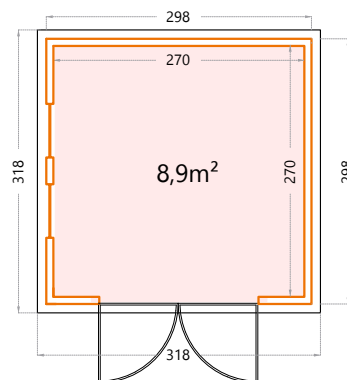

Height: 265cm

Door opening - double door: 177x198cm.

5436: External dimensions: 538x358cm - Internal dimensions: 510x330cm.

Windows: tilt

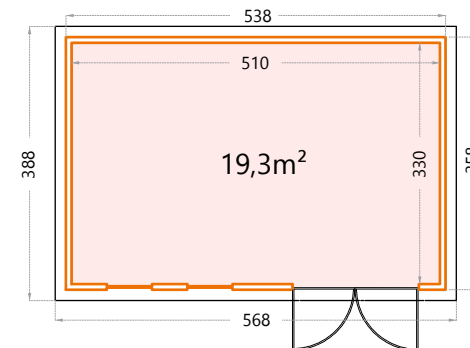



Steel is a sustainable construction material

All profiles are made of galvanised (hot-dipped) steel. The steel plates have a 275g/m² zinc layer, ensuring an Eleganto garden building never rusts.

TELLURIA only uses high-grade steel delivered by European suppliers.

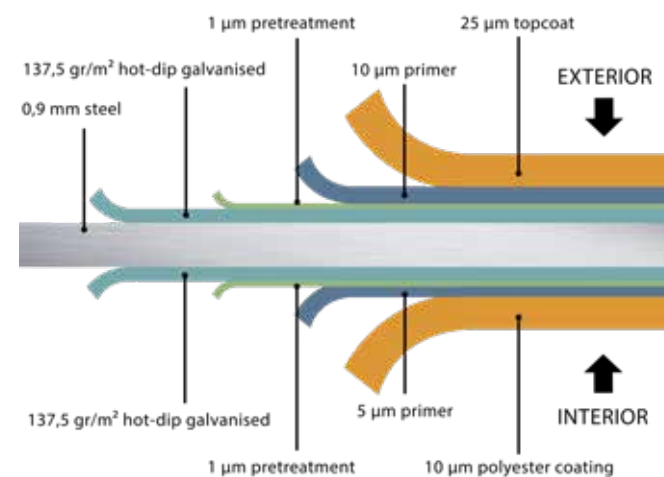

These suppliers produce steel using state-of-the-art, efficient processes, from raw material to the finished product. This means we can guarantee you optimum product procurement for in your garden.

Revolutionary STEEL construction system



Visit our website
www.telluria.eu

STEEL OF LIFE

TELLURIA is an easy to install steel construction system. The countless benefits of steel mean this system will play a vital role in the future; with its flexibility the system inspires the realisation of people's dream constructions.

ON-SITE PRODUCTION

All TELLURIA components are of European origin, produced at our site in Belgium. Our fully standardised and automated production process is continuously monitored, resulting in premium products. The components and constructions are comprehensively and stringently tested, using only high-grade materials. As a result they can cope with extreme conditions (they are fire-resistant, can withstand high winds ...).



**PRODUCED IN
BELGIUM**
(TONGEREN)

↑telluria

LET US STEEL YOUR HEART

TELLURIA

Steel of Life
+32 (0)12 33 90 00
info@telluria.eu

Produced by Telluria NV

Eastern industrial zone – No. 5 Michielenweg
3700 TONGEREN | Belgium