



ST-3000.1D

ST-4500.1D

ST-5500.1D

ST-500.4

Before You begin installation

Before you begin , you will need tools, supplies and adapters. It is best to make sure you have everything you need before you start.

Amplifier Location

Allow air circulation around the amplifier.

The amplifier's compact design allows greater flexibility in mounting. it can be mounted under the seat and in the trunk.

When selecting a location, remember that amplifiers generate heat. Select a location where air can circulate around the amplifier.

Do not cover the amplifier with carpets or enclose it behind interior trim panels.

Every installation will be a bit different based upon vehicle design, check all locations and placements carefully before making any cuts or connections.

Disconnect Battery

Before you begin, always disconnect the battery negative terminal.



Important:

If wiring connections are made incorrectly the unit will not operate properly and could be damaged. Follow the installation instructions carefully or have the amplifier installed by an authorized dealer.

Things to remember when installing your STEALTH SERIES amplifiers.

The design philosophy of **STEALTH SERIES** amplifiers and mode of regulation requires that proper installation and load impedance instructions be adhered to at all times.

Minimum impedance recommended for ST-3000.1D, ST-4500.1D and ST-5500.1D are 1ohm.

For master/slave link operation, the minimum impedance for ST-3000.1D, ST-4500.1D and ST-5500.1D are 2ohm. Each master amplifier must be paired up with a exact same model as slave amp.

Minimum impedance for ST-500.4 is 2ohm stereo or 4ohm mono.

All Stealth series amplifiers are not equipped with fuses. Pls use external fuses for all stealth series amplifiers. External fuse ratings are 120A for ST-3000.1D, 150A for ST-4500.1D, 200A for ST-5500.1D and 120A for ST-500.4.

These fuse ratings should be sufficient under normal working conditions. However, if the amplifiers are overloaded (see minimum impedance above) fuses may blow.

Therefore, please try to avoid operating the amplifiers under these conditions.

1. Mount the amplifiers where air flow is the best.
2. Mount the amplifiers to a solid surface away from vibration, as these amplifiers are heavy and the vibration can damage the amplifiers.
3. Take extreme caution when mounting the amplifiers, so as not to damage the chassis with a drill or screwdriver.
4. Run 4AWG (ST-3000.1D, ST-4500.1D and ST-500.4) or 0AWG (ST-5500.1D) wire from the battery, using fuses with 12" of the positive battery terminal.

The fuse is to protect the car and your car audio system from the fire that could be caused by a short circuit.

INSTALLATION



5. Run 4AWG (ST-3000.1D, ST-4500.1D and ST-500.4) or 0AWG (ST-5500.1D) ground wire as short as possible, to the closest chassis ground point. Be sure to remove the paint around the chassis ground point to provide a more solid electrical connection.
6. Run a 16 AWG (or larger) wire to the remote turn-on lead of the headunit.
7. Connect the speakers as per wiring diagrams in the manual.
12AWG or larger speaker wire is recommended.
8. Mount remote level control in the car where it can be easily reached from the driver's seat, if desired.
9. Using rca interconnect cables, connect all line inputs per the wiring diagrams which follow.
If possible, keep rca cables away from the 12V power and ground wire.
10. Set the controls as described on following pages.

Power, Remote, Ground Connection.

Power Terminal (+12V)

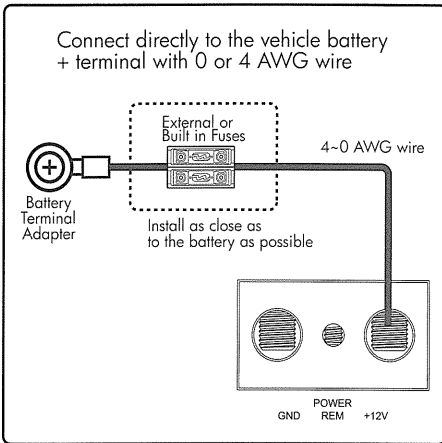

Ground Terminal (GND)

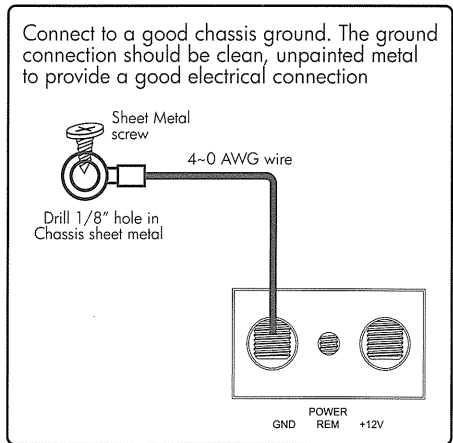

Remote / Turn on Terminal

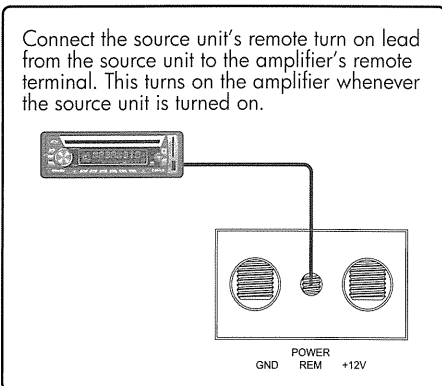

Fuses

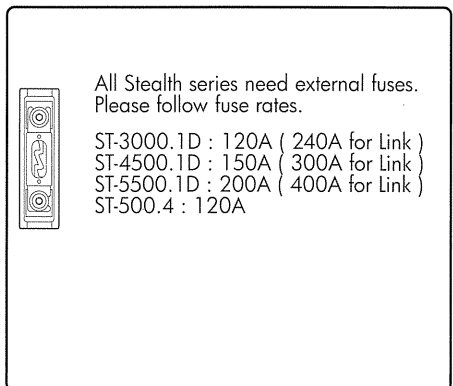

DIGITAL MONOBLOCK INPUT & OUTPUT CONNECTION

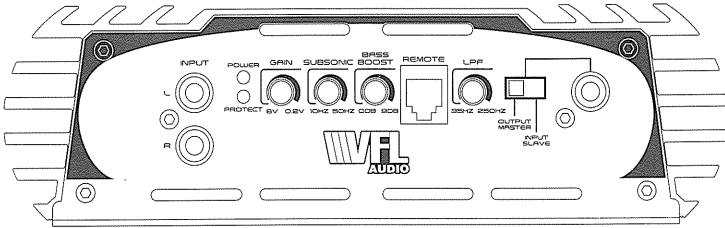

RCA INPUTS

The RCA inputs ensure the highest quality contacts and the lowest noise in your audio system.

POWER & PROTECT INDICATORS -

When the unit is powered on and operating correctly the power LED illuminates. When the unit is malfunctional or protected, then protect LED is turned on.

GAIN (6V - 0.2V)

This adjusts the normal operating level of the amplifier by matching the level from the headunit.

SUBSONIC FILTER (10Hz - 50Hz)

This allows you to tune the response of the amplifier at very low frequencies.

BASS BOOST (0 - 9dB)

This allows you to tune amplifier response with up to 9dB of boost centered at 45Hz

REMOTE CONTROL

Use this to control level of the amplifier from your driver's seat.

LOW PASS FILTER (35Hz - 250Hz)

This allows you to tune the response of the amplifier at higher bass frequencies to roll off for a seamless integration into your midbass.

MASTER/SLAVE (LINK) CONNECTION

Using one amplifier set this to Output Master. Second amp is set to Input Slave
In Strappable mode, minimum impedance is 2ohm
Subwoofer speakers impedance should be checked very carefully to prevent any damages to subwoofers and the amplifiers.

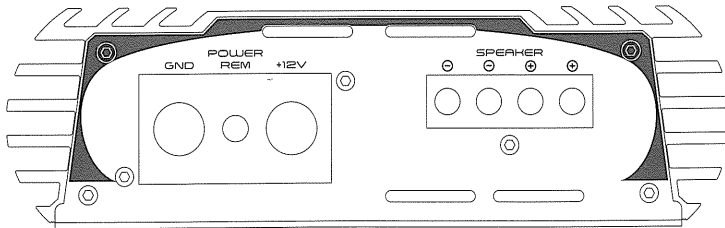

GROUND (GND) & POWER (+12V)

The power and ground will accommodate 0 or 4 AWG wire. Use high quality pure copper wire only.

REMOTE (REM)

REM connector will accept wire sizes from 12 to 18 AWG. This terminal is used to remotely turn-on and turn-off the amplifier when +12V DC is applied.

SPEAKER TERMINAL BLOCK

Connect speaker cables from speaker terminal block to subwoofers. Subwoofers impedance should be checked carefully.

DIGITAL MONOBLOCK POWER CONNECTION

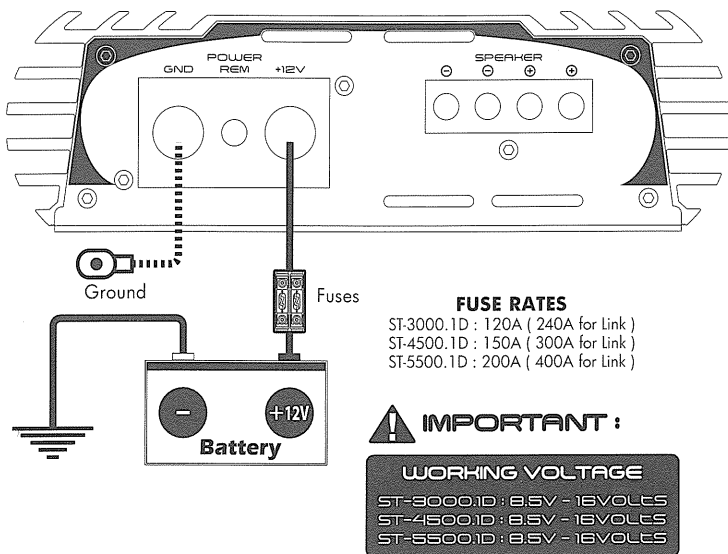

DIGITAL MONOBLOCK SPEAKER CONNECTION

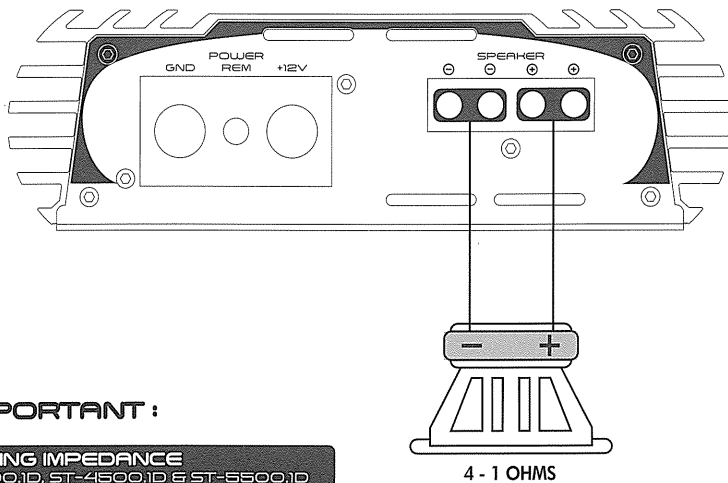

MASTER / SLAVE (LINK) INPUT CONNECTION

INPUT CONNECTION STEPS ;

- Step 1. Set output master / input slave switch to **OUTPUT MASTER** on master amplifier.
- Step 2. Set output master / input slave switch to **INPUT SLAVE** on slave amplifier.
- Step 3. Connect **RCA JACK** on master amp to **RCA JACK** on slave amp.

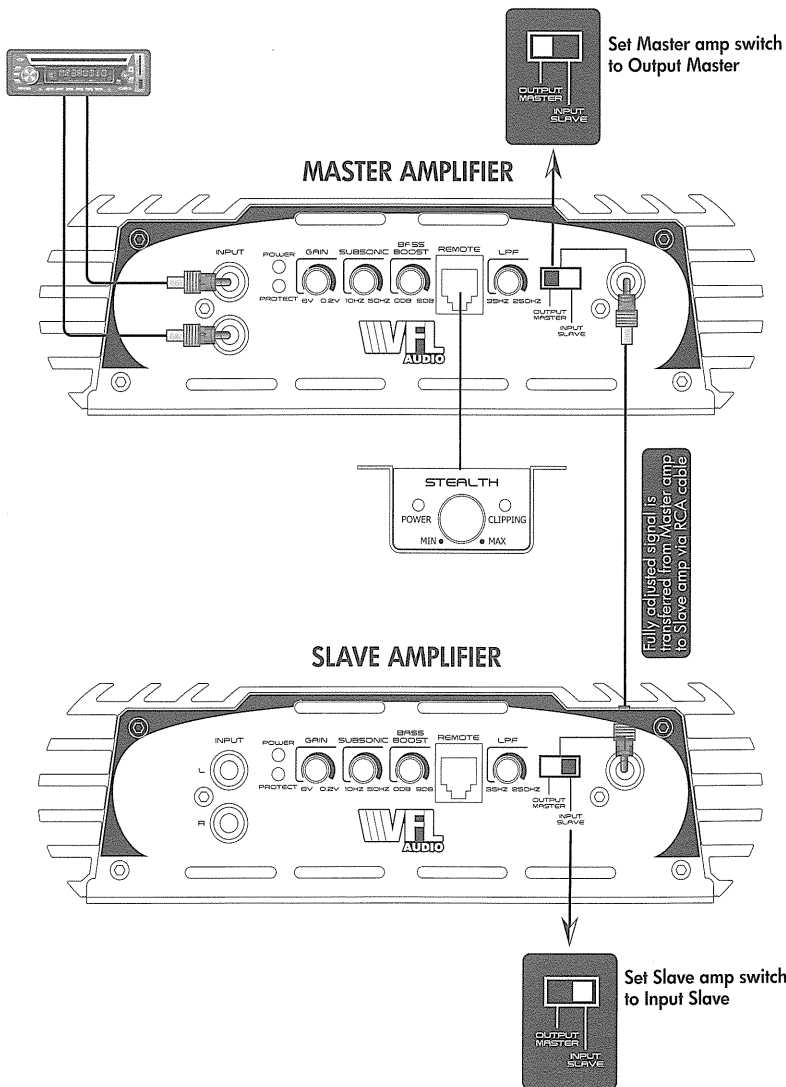

MASTER / SLAVE (LINK) SPEAKER OUTPUT CONNECTION

SPEAKER OUTPUT CONNECTION STEPS ;

- Step 1. Connect speaker cable (+) on master amplifier to subwoofer (+)
- Step 2. Connect speaker cable (+) on slave amplifier to subwoofer (-)
- Step 3. Connect speaker cable (-) on master amplifier to speaker cable (-) on slave amplifier

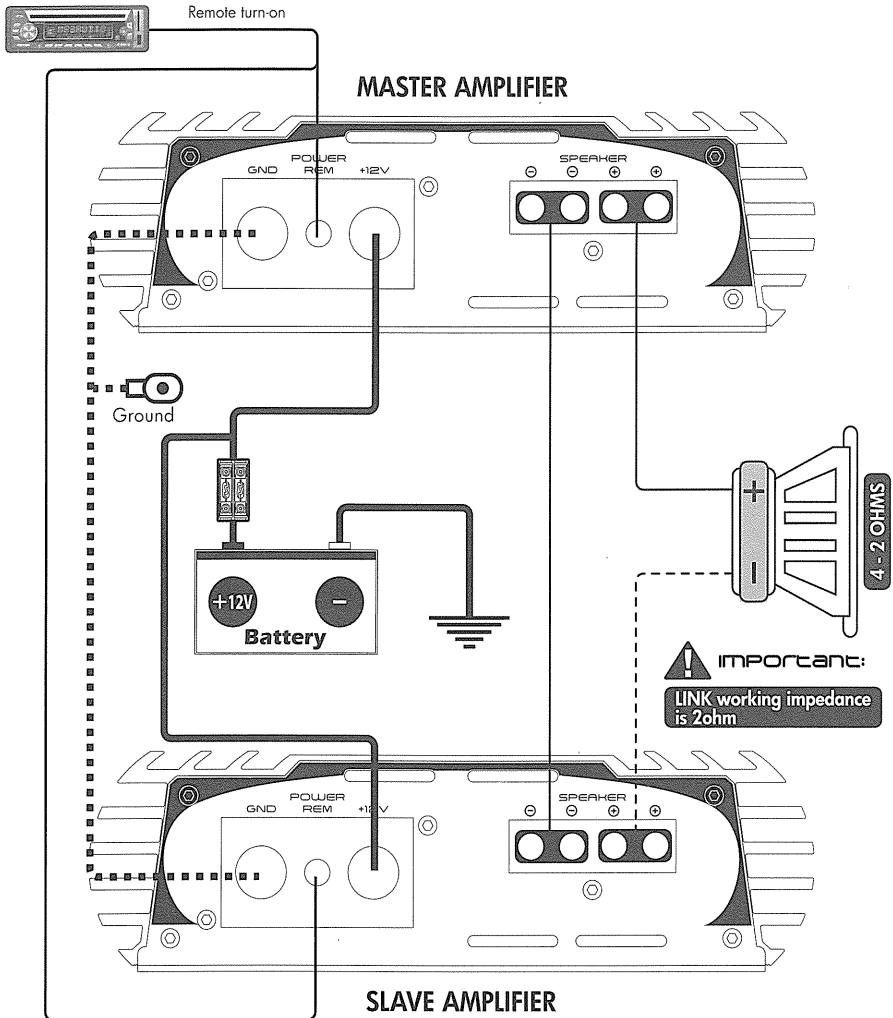

ST-500.4 4CHANNEL INPUT & OUTPUT CONNECTION

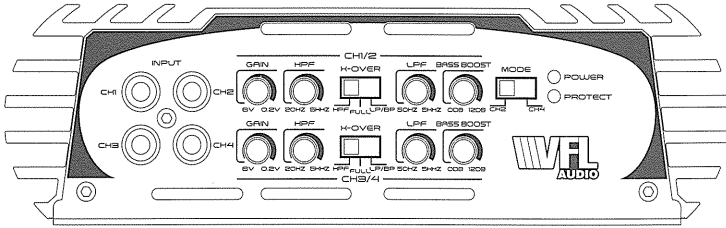

RCA INPUTS

The RCA inputs ensure the highest quality contacts and the lowest noise in your audio system.

GAIN (6V - 0.2V)

This adjusts the normal operating level of the amplifier by matching the level from the headunit.

HIGH PASS FILTER (20Hz - 5KHz)

Controls the high pass cutoff point for the speaker outputs. HPF can be selected with X-over switch located next to it.

X-OVER (HPF/ FULL /LP-BP)

At HPF, High pass filter is activated
At FULL, It is bypass.

At LP-BP, Low pass and band pass filter are activated. Pls set HPF frequency at minimum for band pass filter activated.

LOW PASS FILTER (50Hz - 5KHz)

Controls the low pass cutoff point for the speaker outputs. LPF can be selected with X-over switch located next to it.

BASS BOOST (0 - 12dB)

This allows you to tune amplifier response with up to 12dB of boost centered at 45Hz.

MODE (CH2 / CH4)

MODE switch selects its input connection.

POWER & PROTECT INDICATORS -

When the unit is powered on and operating correctly the power LED illuminates.

When the unit is malfunctional or protected, then protect LED is turned on.

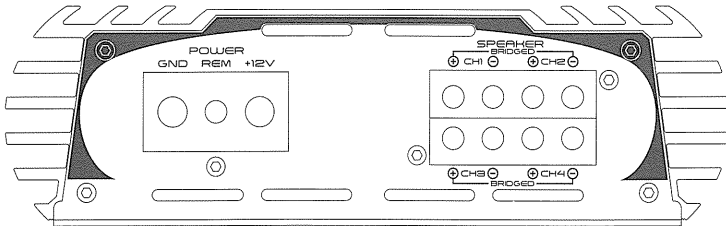

GROUND (GND) & POWER (+12V)

The power and ground will accommodate 4 AWG wire
Use high quality pure copper wire only.

REMOTE (REM)

REM connector will accept wire sizes from 12 to 18 AWG.
This terminal is used to remotely turn-on and turn-off the amplifier when +12V DC is applied.

SPEAKER TERMINAL BLOCK

Connect speaker cables from speaker terminal block to speakers.

Speakers impedance should be checked carefully. They are 2ohm stereo stable or 4ohm mono.

ST-500.4 SPEAKER OUTPUT CONNECTION

4CHANNEL WIRING MODE

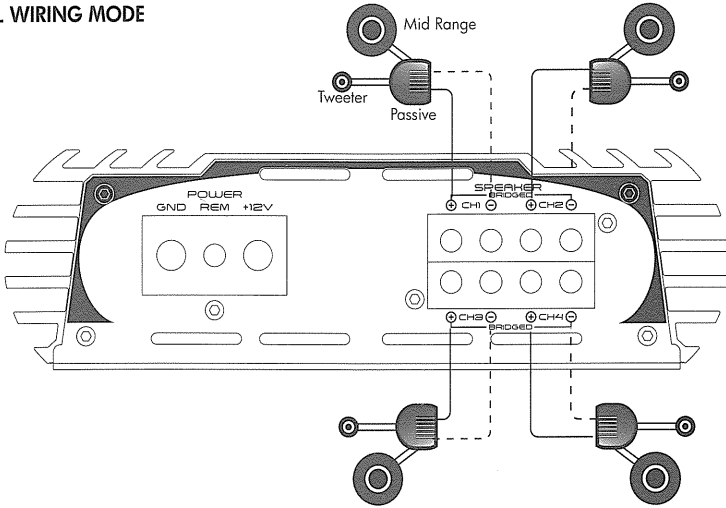

5CHANNEL WIRING MODE

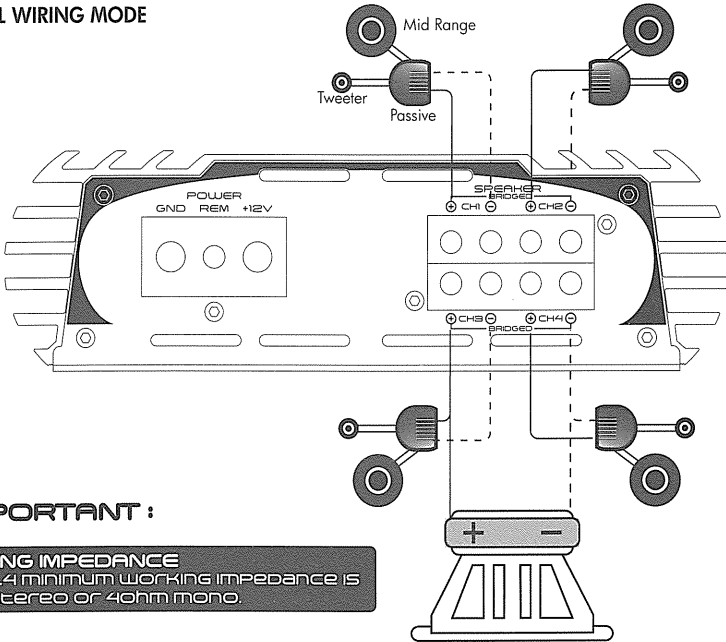

! IMPORTANT :

WORKING IMPEDANCE
ST-500.4 minimum working impedance is 2ohm stereo or 4ohm mono.

TROUBLE SHOOTING**NO POWER LED ON, NO OUTPUT**

- Check +12V and GND connection
- Check remote signal +12V
- Check the external fuses or built-in.

POWER LED ON, NO OUTPUT

- Check source unit for output
- Check input gain control
- Check RCA cable
- Check speaker and wiring for shorts
- Check for damaged speakers

NO SOUND ON ONE CHANNEL

- Swap left/right input to check source
 - ... If sound swaps too, source or signal cable is bad
- Swap left/right speaker to check speakers
 - ... If sound does not swap, speaker or speaker wiring is bad
 - ... In any case, consult authorized dealer

AMPLIFIER GOES IN PROTECTION MODE AT HIGHER GAIN

- Check speaker impedance (ST-3000.1D, ST-4500.1D and ST-5500.1D are 1ohm for single unit and 2ohm for link connection. ST-500.4 is 2ohm stereo or 4ohm mono)
- Check working voltages (8.5V - 16Volts)
- Check speaker wiring for short circuit

ENGINE OR ALTERNATOR WHINE NOISE

- Check wiring. make sure RCA cables are not run parallel on same side of vehicle as power cable.
- Check any preamps or black boxes in the signal path between source unit and amplifier
- Make sure ground pin (shield or outer barrel of rca cables) have not lost connection and that source unit has good reference ground.

Features

DIGITAL MONOBLOCK AMPLIFIER

- ⊙ Digital linkable/dual mono block amplifier
- ⊙ Dual MOS-FET PWM power supply
- ⊙ Fully stable into 1ohm (2ohm for link)
- ⊙ Variable Subsonic filter
- ⊙ Variable Low pass filter
- ⊙ Variable Bass boost
- ⊙ Wired Remote control with Clipping indicator
- ⊙ Surface Mount Technology
- ⊙ Multi-way protection circuitry
(DC, Speaker Short, Thermal and Voltage)

MULTI-CHANNEL AMPLIFIER

- ⊙ 2ohm stereo stable Class AB
- ⊙ Variable High pass filter
- ⊙ Variable Low pass filter
- ⊙ Band-pass capable
- ⊙ Variable Bass Boost
- ⊙ Surface Mount Technology
- ⊙ PCB mounting fan cooling
- ⊙ Double sided printed circuit board
- ⊙ Multi-way protection circuitry
- ⊙ (DC, Speaker Short, Thermal and Voltage)

Specifications

STEALTH-SERIES	ST-3000.1D	ST-4500.1D	ST-5500.1D	ST-500.4
No of Channels	1CH	1CH	1CH	4CH
Congiguration	Digital Mono	Digital Mono	Digital Mono	Class AB
Frequency Response	15Hz - 270Hz	15Hz - 270Hz	15Hz - 270Hz	10Hz - 50KHz
Signal to Noise Ratio	85dB	85dB	85dB	105dB
Efficiency @ 4ohm	Over 90%	Over 90%	Over 90%	Over 70%
Damping Factor	150 <	150 <	150 <	150 <
Input Sensitivity	6V - 0.2V	6V - 0.2V	6V - 0.2V	6V - 0.2V
Subsonic Filter	10Hz - 50Hz	10Hz - 50Hz	10Hz - 50Hz	na
Low Pass Filter	35Hz - 250Hz	35Hz - 250Hz	35Hz - 250Hz	50Hz - 5KHz
High Pass Filter	na	na	na	20Hz - 5KHz
Bass Boost @45Hz	0dB - 9dB	0dB - 9dB	0dB - 9dB	0dB - 12dB
THD @ 4ohm	< 0.1%	< 0.1%	< 0.1%	< 0.1%
Fuse Rating	120A	150A	200A	120A
(Link Fuse Rating)	240A	300A	400A	na
Dimensions (L inches)	11.81 inches	13.78 inches	17.72 inches	19.69 inches
7.87W x 2.22H inches				

All features are subject to change in the continuing efforts to improve the products without notice.



www.americanbassusa.com