

Assembling is a "Skill". Let's make you learn a new skill today if you haven't known already.

## **NEWYORK SUPERB High Back Chair**



**Task Type: Easy to Moderate**



**Time required: 20 Minutes (approx)**



**Required Tools: Available in the box**



**Person Required: 1 (2 would be great)**



**Benefits: A Great Ergonomic Chair (self assembled)**

**Visit [www.greensoul.online](http://www.greensoul.online) for more information**





## Available Components

**A.**

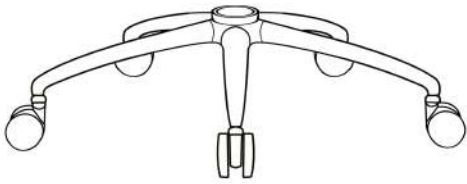

**Base Stand  
with Wheels**

**B.**



**Base Cover**

**C.**



**Hydraulic  
Gas Lift**

**D.**

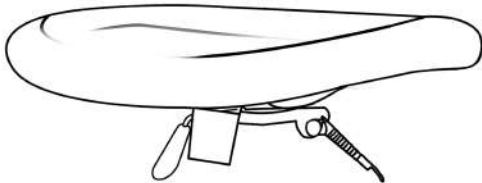

**Seat**  
(Mechanism attached)

**E.**

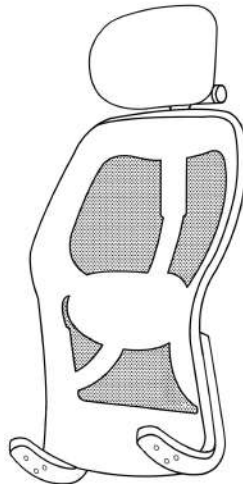

**Back**  
(Headrest attached)

**F.**

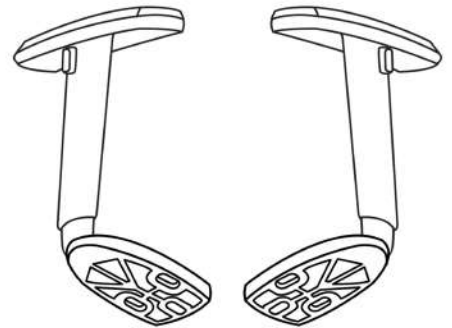

**Armrests**

**G.**



**Allenkey**

**Check if you have received all the parts  
or else contact us immediately by  
Phone or Whatsapp:-**

**+91 844-8444-695**



# Let's Start Assembling

## Step 1 :- Gas Lift Fitting

### Required Parts

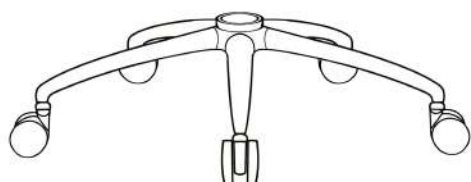

**A.**



**B.**



**C.**

### Process

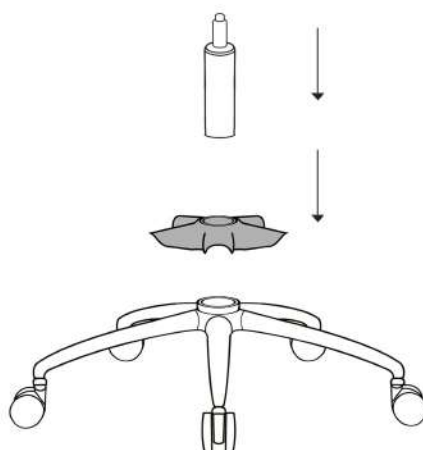

**After Connecting  
(It should look like this)**

**Base for the Chair is ready**

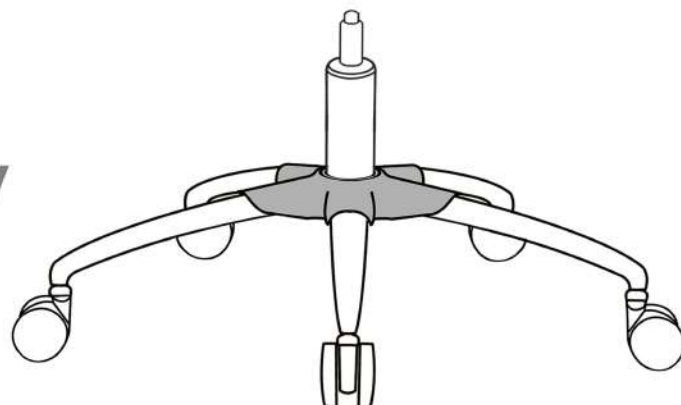

**Good Job!**

**25% Done**





# Step 2 :- Connecting Seat & Back

## Required Parts

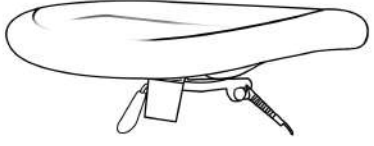

D.

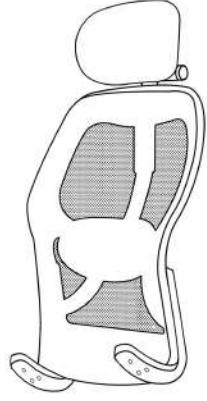

E.



G.

## Process

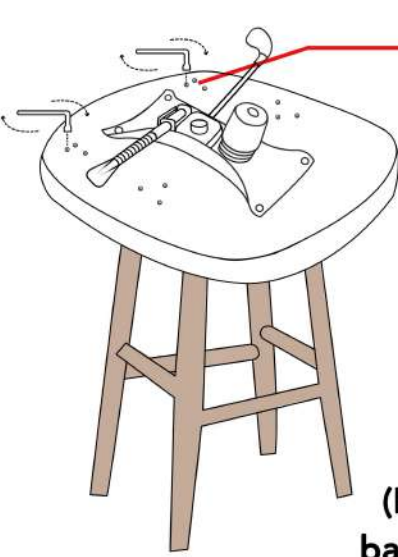

**Remove the 6 screws**  
(Pre attached with back, 3 on each side)

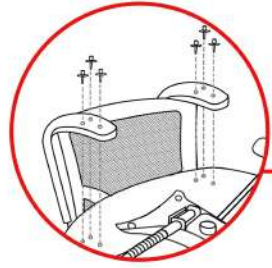
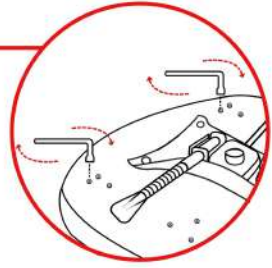

**Connect back and seat with the same 6 screws**  
(The chair is placed on some random stool)

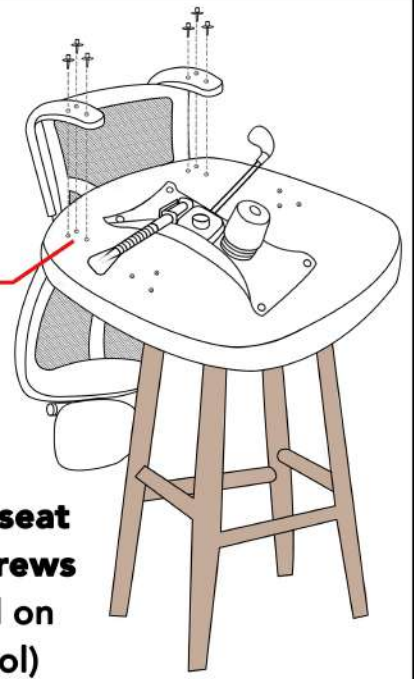

## After Connecting (It should look like this)

Upperbody of the Chair is almost ready.  
(Just armrests needs to fixed)

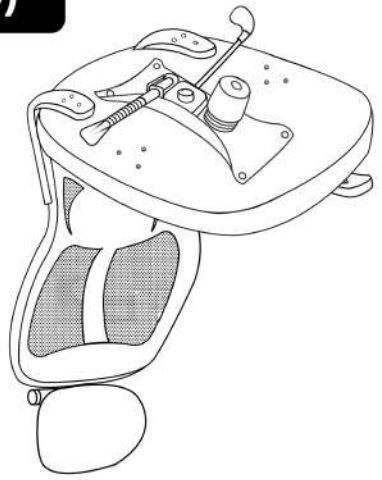

Wonderful



50% Done



# Step 3 :- Fitting the Armrests

## Required Parts

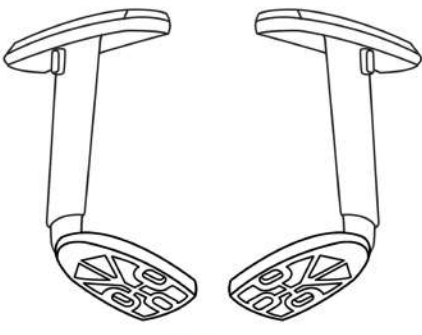

F.



G.



Upper Body  
(without armrests)

## Process

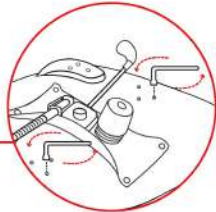
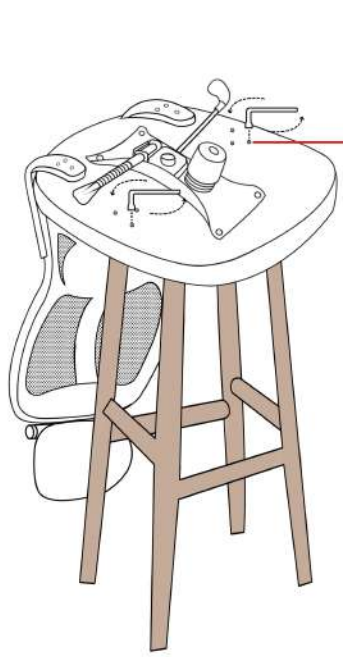

Remove the 6 screws attached to the seat. (3 each side)

Attach the Armrests with the seat using the same 6 screws

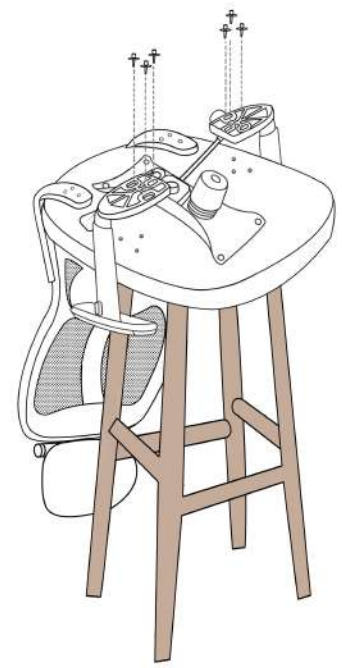

## After Connecting (It should look like this)

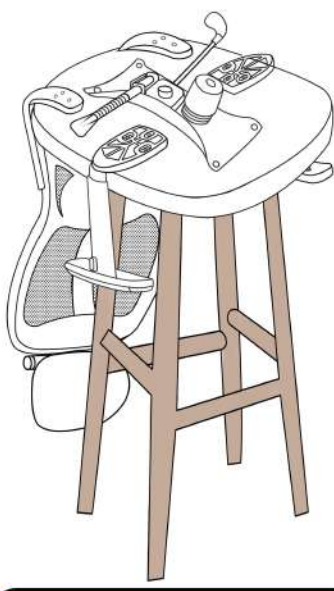

Upperbody of the Chair is ready.

Almost there



75% Done



## Step 4 :- Connecting the Upperbody and Base

### Required Parts

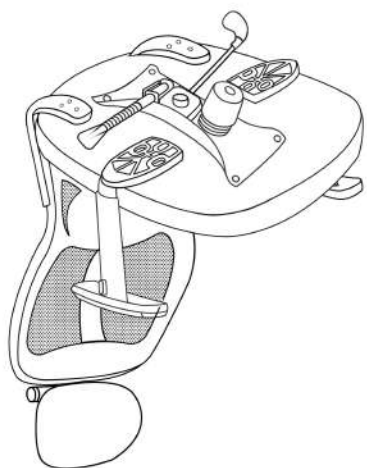

UpperBody

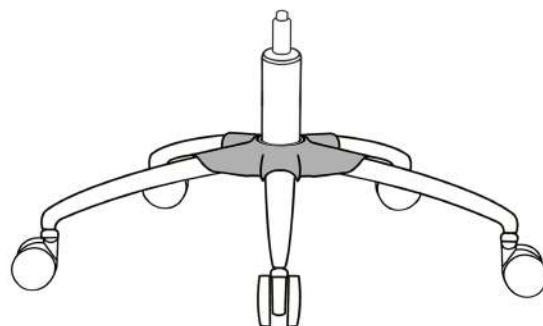

Bottom Base

### Process

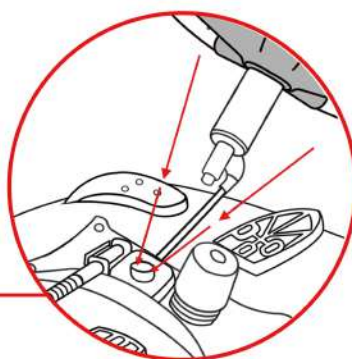
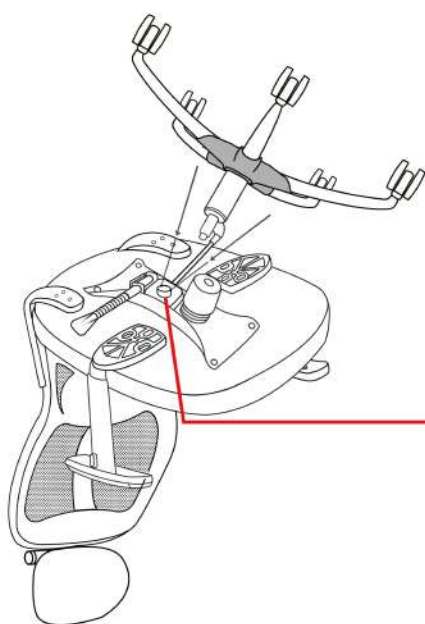

Connect Upperbody  
with the Bottom

After Connecting  
(It should look like this)



You have assembled the chair,  
and now you can start using the same.

**Congratulations!**

**100% Done**



# Adjustments

## 1. Adjusting the Seat Height:

To raise your seat, vacate the seat & pull up the lever placed below the seat.

To lower the seat, pull up the control handle while you're seated.



## 2. Backrest Locking:

To relax, lock at any position between 90° to 135° using the left side lever.



## 3. Backrest Tension Control:

Turn the tilt knob clockwise to make it harder to rock your chair backwards.

Turn the tilt knob anti-clockwise to make it easier to rock your chair backwards.



Note: If your chair won't tilt back, pull out the right side control handle

# Cleaning and Maintenance

- Periodically clean the seat cover using a vacuum cleaner. Use the correct attachment for vacuuming upholstery. Use the setting for upholstery (low suction).
- Use a dry sponge to remove dirt.
- If required, use a slightly damp cloth to clean heavily soiled areas, then wipe dry using a dry cloth.
- Occasionally, thoroughly wipe the frame using a slightly damp cloth. Then dry the frame using a dry cloth.
- Do not use strong cleaning agents or abrasives.
- Do not use the chair unless all screws are securely tightened. Screws and joints should be re-tightened regularly.



## Safety and Compliance

- Use care when handling.
- Assemble the chair on carpet to prevent scratching the chair.
- Do not use power tools.

**Item Code:-**

**NewYork-Superb\_HB\_Black\_V1\_297**

In case of any manufacturing defects, please contact us at  
+91 844-8444-695 | [info@greensoul.online](mailto:info@greensoul.online)

Monday to Saturday: 9:30 AM - 6 PM