

Assembling is a "Skill". Let's make you learn a new skill today if you haven't known already.



Task Type: Easy to Moderate



Time required: 15 Minutes (approx)



Required Tools: Available in the box



Person Required: 1 (2 would be great)



Benefits: A Great Ergonomic Chair (self assembled)

Visit www.greensoul.online for more information

CRYSTAL V2 Mid Back Chair





Available Components

A.

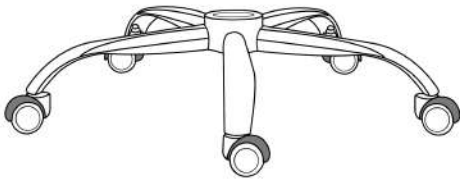

**Base Stand
with Wheels**

B.



Base Cover

C.



**Hydraulic
Gas Lift**

D.

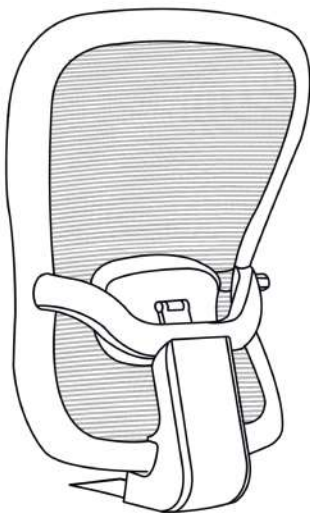

Back

E.

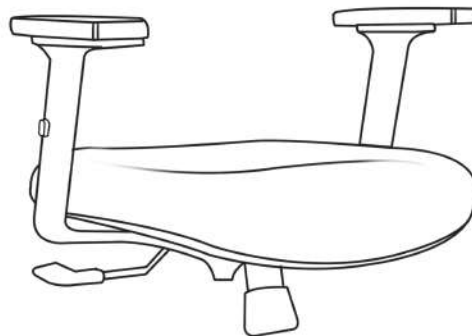

Seat
(Armrests and
Mechanism attached)

F.



Allen key

**Check if you have received all the parts
or else contact us immediately by
Phone or Whatsapp:-**

+91 844-8444-695



Let's Start Assembling

Step 1 :- Gas Lift Fitting

Required Parts



A.



B.



C.

Process

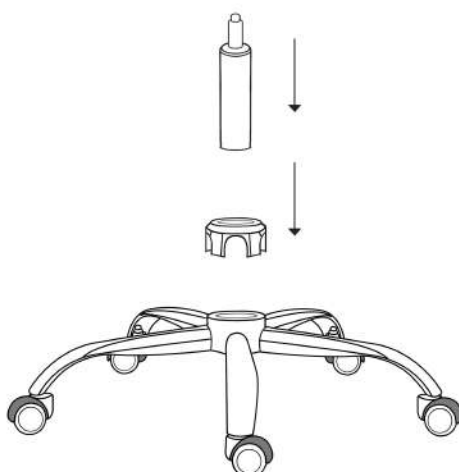

After Connecting
(It should look like this)

Base for the Chair is ready

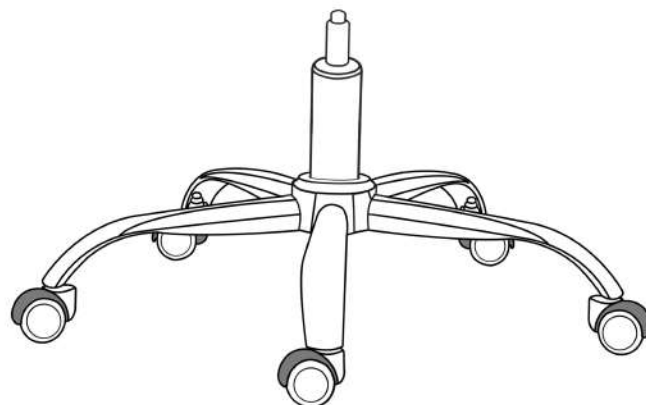

Good Job!

33% Done



Step 2 :- Connecting Seat & Back

Required Parts

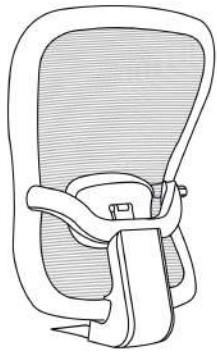

D.

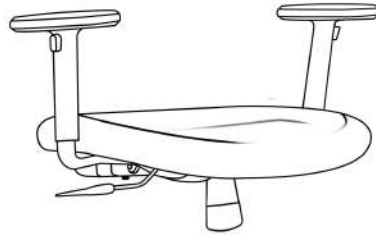

E.



F.

Process

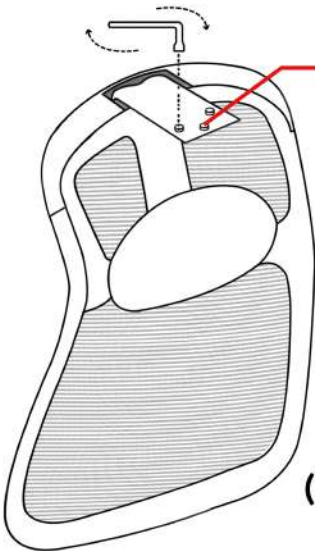

Remove the 3 screws
(Pre attached with back)

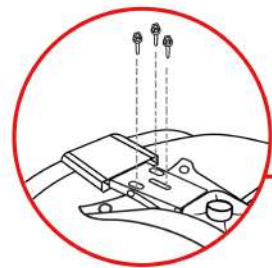
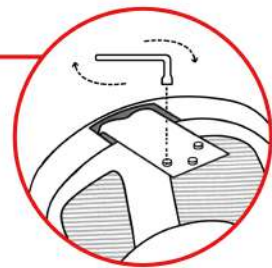

Connect back and seat
with the same 3 screws
(The chair is placed on
some random stool)

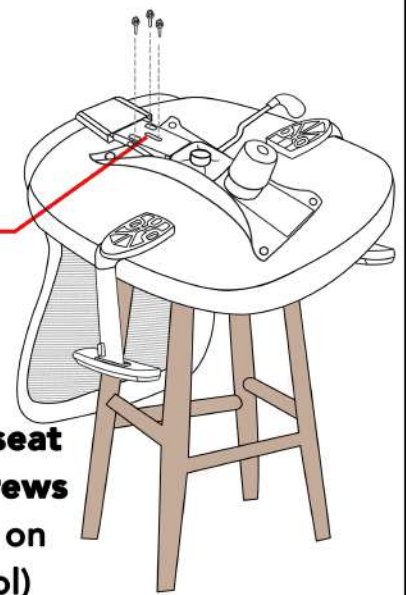

After Connecting (It should look like this)

Upperbody of the Chair is ready

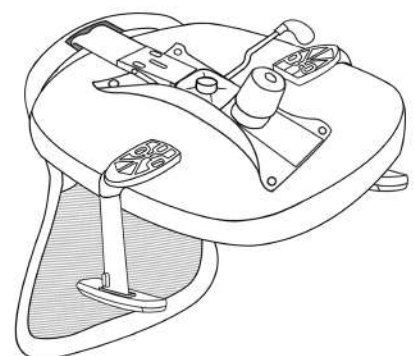

Almost there



66% Done



Step 3 :- Connecting the Upperbody and Base

Required Parts

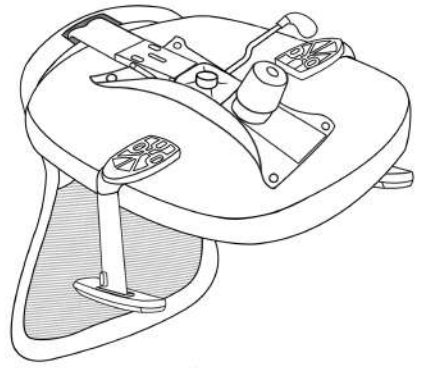

UpperBody

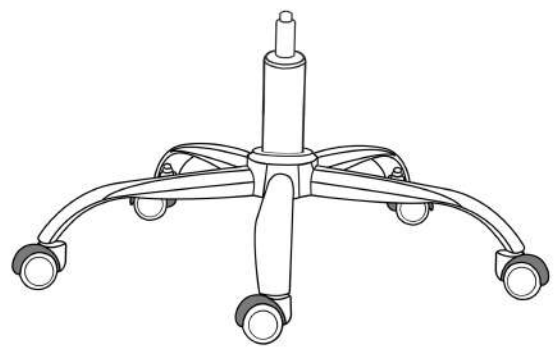

Bottom Base

Process

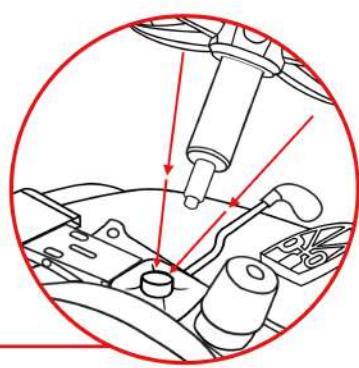
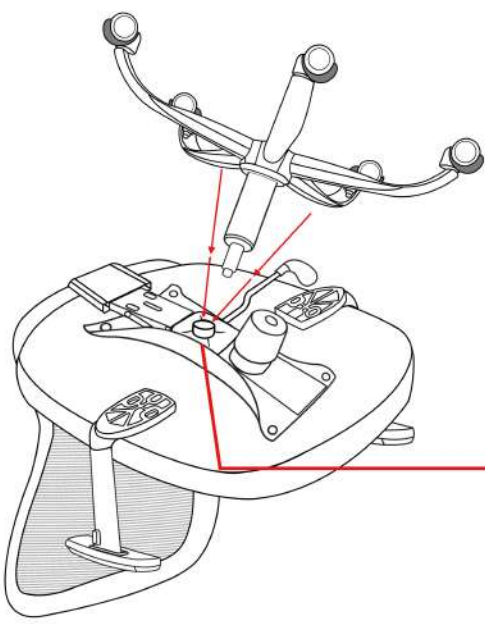

Connect Upperbody with the Bottom

After Connecting (It should look like this)



You have assembled the chair, and now you can start using the same.

Congratulations!



100% Done



Adjustments

1. Adjusting the Seat Height:

To raise your seat, vacate the seat & pull up the lever placed below the seat.

To lower the seat, pull up the control handle while you're seated.



2. Backrest Locking:

To let your chair tilt back, pull the control handle out.

To stop your chair from tilting, sit forward, then push the control handle in.



3. Backrest Tension Control:

Turn the tilt knob clockwise to make it harder to rock your chair backwards.

Turn the tilt knob anti-clockwise to make it easier to rock your chair backwards.



Note: If your chair won't tilt back, pull out the control handle



Adjustments

4. 2D Adjustable Armrest

To adjust the height of the armrest, press the button on the side of the arm support and move the arm up or down. Release the button to lock.

Forward and Backward



5. Adjustable Lumbar Support:

Pull up or down manually to adjust to preferred lumbar support height.

You can also flip the lumbar support backward and forward.



Safety and Compliance

- Use care when handling.
- Assemble the chair on carpet to prevent scratching the chair.
- Do not use power tools.

Cleaning and Maintenance

- Periodically clean the seat cover using a vacuum cleaner. Use the correct attachment for vacuuming upholstery. Use the setting for upholstery (low suction).
- Use a dry sponge to remove dirt.
- If required, use a slightly damp cloth to clean heavily soiled areas, then wipe dry using a dry cloth.
- Occasionally, thoroughly wipe the frame using a slightly damp cloth. Then dry the frame using a dry cloth.
- Do not use strong cleaning agents or abrasives.
- Do not use the chair unless all screws are securely tightened. Screws and joints should be re-tightened regularly.



Item Code:-

Crystal_MB_Black_VDR22_301

In case of any manufacturing defects, please contact us at

+91 844-8444-695 | info@greensoul.online

Monday to Saturday: 9:30 AM - 6 PM