

This Product Must Not Be Modified | Approx Install Time : 4Hrs

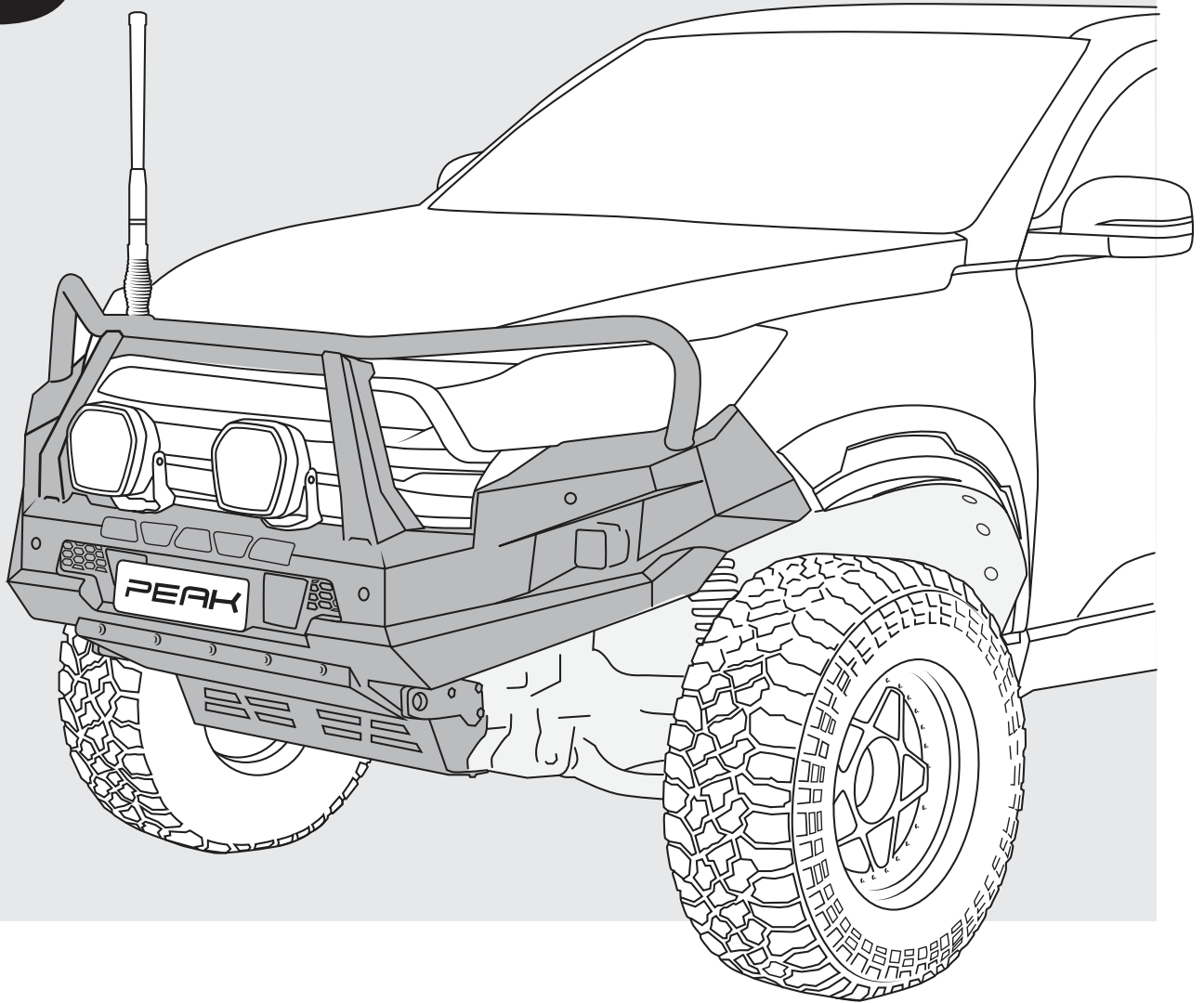

# PEAK M1 NIGHTHAWK

## Installation Manual

SSANGYONG MUSSO Q200/Q201/Q215/Q250/Q261

No Loop SYPEAK0419S / Single Loop SYPEAK0423S / Triple Loop SYPEAK0427S

**IMPORTANT :**

Bull Bar installations should only be done by a qualified person and it is the responsibility of this person to ensure correct fitment

# DISCLAIMER

## **Important Notice Regarding Installation and Warranty**

Thank you for choosing the PEAK M1 NightHawk. This manual contains essential instructions for proper installation and usage. It is of utmost importance that you carefully read and follow these guidelines. Additionally, we want to emphasize the critical role of experience and expertise in installing this bull bar correctly.

## **Experienced Installation**

Installing a bull bar requires a certain level of technical skill and knowledge. We strongly recommend that the installation be carried out by a qualified professional who has experience with vehicle modifications and bull bar installation. Incorrect installation can lead to safety hazards and vehicle damage.

## **Voidance of Warranty**

Please be aware that improper installation, use of unauthorized parts, or installation by unqualified individuals can void the warranty of the bull bar and associated components. Any damage resulting from improper installation or use will not be covered under warranty.

## **Liability and Responsibility**

We, the manufacturer, cannot be held responsible for any damage, injury, or loss caused by improper installation, modification, or usage of this product. It is the responsibility of the installer and the vehicle owner to ensure that installation is conducted according to the instructions provided in this manual.

## **Safety First**

Your safety and the safety of others on the road are paramount. If you are not confident in your ability to install the bull bar correctly, or if you lack experience in vehicle modifications, we strongly recommend seeking assistance from a certified professional.

## **Professional Installation Recommended**





To ensure optimal performance, safety, and warranty coverage, we strongly advise having your bull bar installed by a qualified technician who is knowledgeable about bull bar installations and adheres to industry standards.

By proceeding with the installation of this bull bar, you acknowledge that you have read and understood this disclaimer, and you accept full responsibility for the installation process and its outcomes.

If you have any questions or concerns, please contact our customer support team before proceeding.

Thank you for choosing our product, and we appreciate your commitment to safety and quality installation.

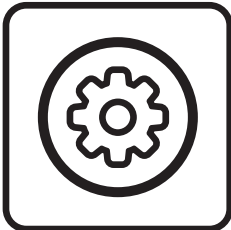
# SAFETY PPE

 <p><b>Ear Protection</b></p>	<p>Always wear ear protection when using power tools.</p>
 <p><b>Safety Glasses</b></p>	<p>Ensure eye protection is always worn when cutting or drilling.</p>
 <p><b>Manual Handling</b></p>	<p>Do not attempt to lift bar assemblies or rock sliders on your own.</p> <p>Always use two people to lift or use mechanical Lifting aid such as hydraulic lifting trolley.</p>
 <p><b>Vehicle Support</b></p>	<p>Always ensure vehicle is properly supported when working on it. Do not attempt to fit products whilst suspension work is being carried out. Do not work under a vehicle supported only by a jack.</p>

# TOOLS

Hacksaw	Ratchet	Socket Set	Spanner Set	Masking Tape
Soldering Iron	Side Cutters	Wire Strippers	Philips-head Screw Driver	Rust Resistant Paint

# SUPPLIED HARDWARE

**Bull Bar**
**x 01**

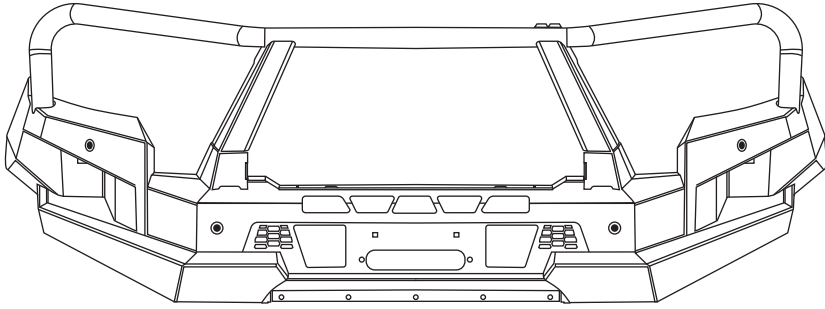

M12x40mm (6 Pieces)

**Compliance Plate**
**x 01**



Noah Industries Pty Ltd  
ACN: 649 230 53  
www.peak-4x4.com.au

Name: Peak M1 Nighthawk  
Part No: SYFEAK04195 / 04235 / 04275 /  
Name: Peak R1 Nighthawk  
Part No: SYFEAK0225 / 03235 / 05275 /

For Vehicles: Saang/Yong Musso (2018 Onwards) -SYFEAK04195 -SYFEAK04235 -SYFEAK04275	Saang/Yong Reinton (2018 Onwards) -SYFEAK0225 -SYFEAK0325 -SYFEAK0275
--	--

For Vehicles equipped with SRS Airbags  
When installed in accordance with the instruction, this front protection bar does not affect compliance to ADR69/00 and operation of SRS Airbag.  
This product or its fitting must not be modified. Warranty void if label is removed.  
No accessory or fitting shall project forward of the product's forward profile. Do not use this product on any other vehicle for which it is not designed.

**Warning Plate**
**x 02**

**WARNING**

PEAK RECOVERY POINT - WLL 5000KG  
8000KG MAX SNATCH STRAP  
4.75t MAX SHACKLE RATING

- INCORRECT USE MAY RESULT IN VEHICLE DAMAGE, PERSONAL INJURY OR DEATH.
- ALWAYS USE RECOVERY POINTS AS A MATCHED PAIR WITH AN EQUALISING BRIDLE.
- RECOVERY ON SIDE ANGLES REDUCES THE RATING OF THE RECOVERY POINT.

### Cassis Mount

x 02

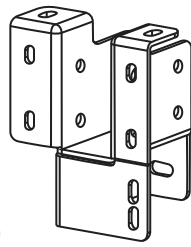

M12x120mm (10 Pieces)  
Crush Tube Small (4 Pieces)  
Crush Tube Large (2 Pieces)

### Recovery Points

x 02

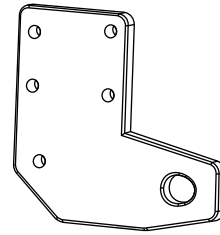

### Centre Cradle

x 01

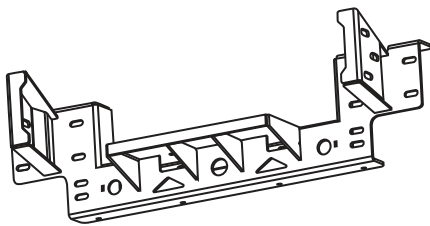

M10x40mm (16 Pieces)

### Bash Plate 01

x 01

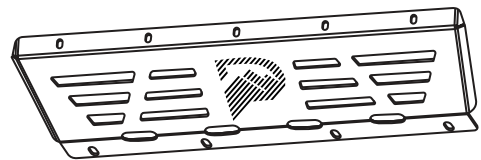

M8x30mm (9 Pieces)

### Bash Plate 02

x 02

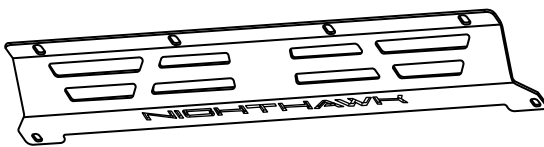

M8x30mm (2 Pieces)

### Bash Plate 03

x 01

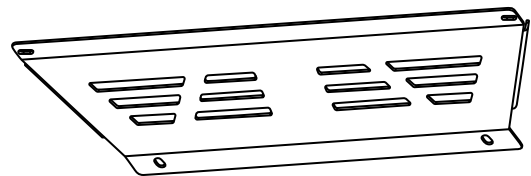

M8x30mm (2 Pieces)

### Wing Support

x 02

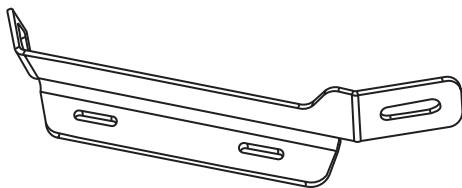

M10x40MM (2 Pieces)

### Front Grill Bracket

x 02



**Number Plate Mount**

**x 01**

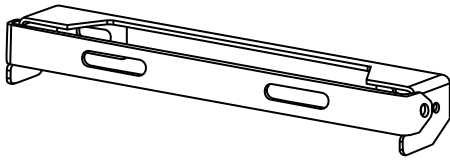

M6 Cage nuts (2 Pieces)  
M6x35mm (4 Pieces)

**STEDI C4 Cube Flood Light**

**x 02**

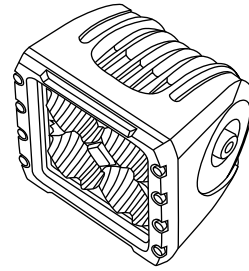

**Leather Key Case**

**x 01**

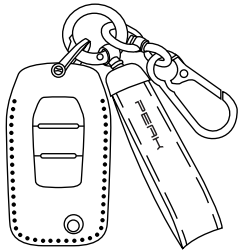

**Fog Light Adapter**

**x 02**

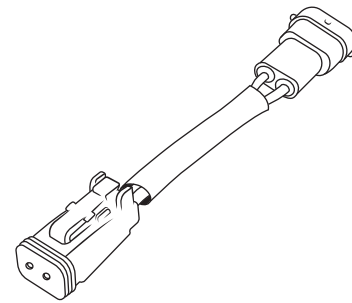

**Sensor Wire Extensions**

**x 02**



**Cable Ties**

**x 10**

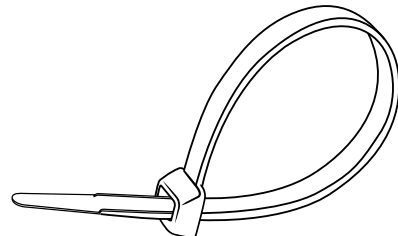

**SENSOR MOUNTING KIT**

**x 01**

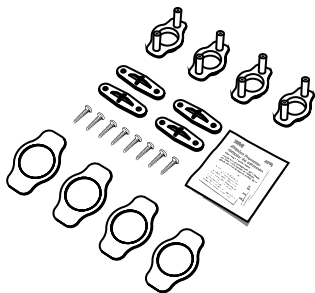

# Part 1

## Removal of Original Bar & Components

1. Open bonnet and remove all screw pins holding on the front cowling in engine bay. Fold back on the rubber seal and place up the engine bay out of the way.

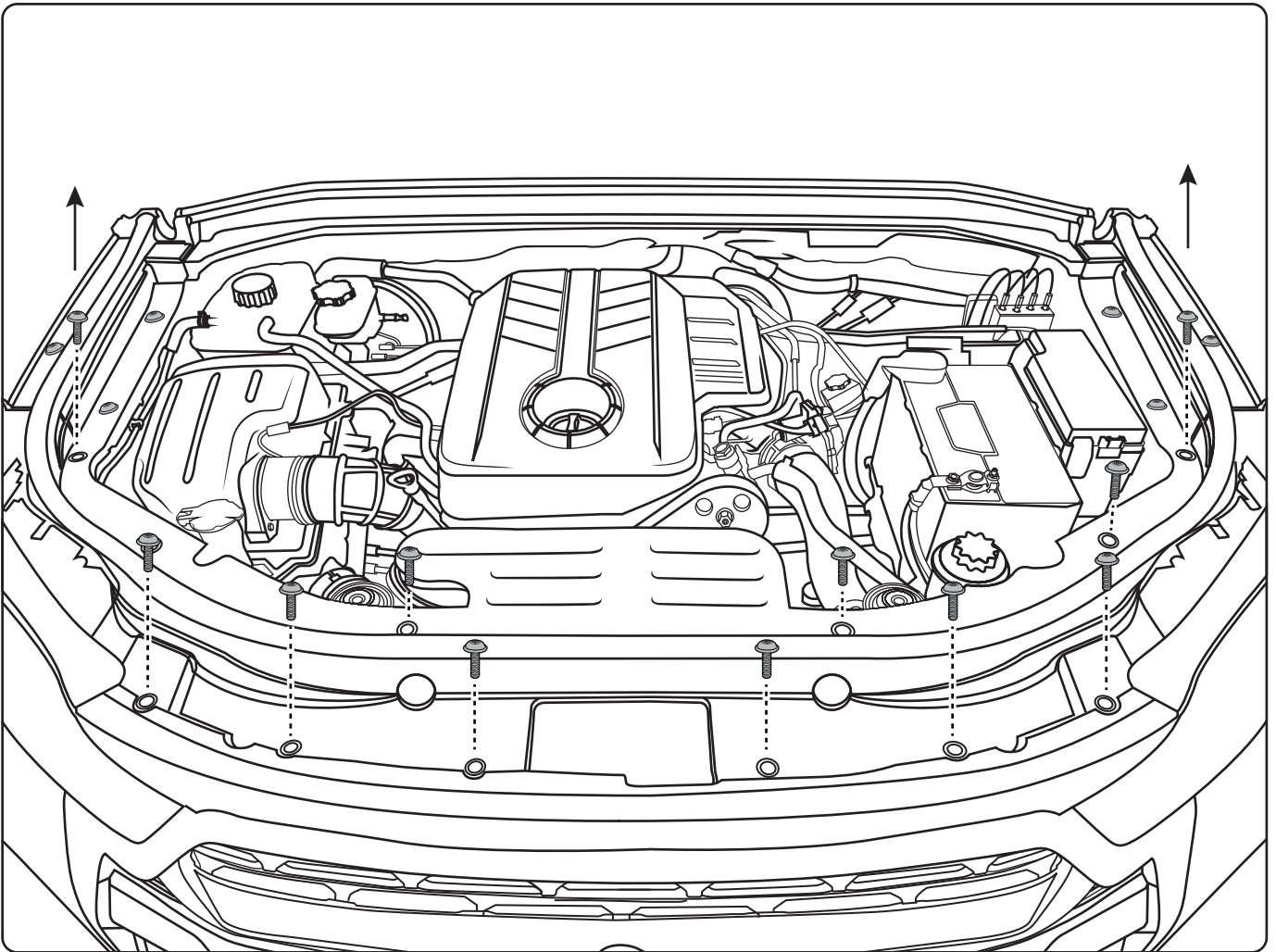

Make sure to retain all original screws & bolts as some are to be re purposed for the install of this product.

**2.** Remove screws a top of the grill.  
(Under cowling).

**3.** Moving to the front wheel arch, remove screws from the inner splash guard on the bumper portion down the inside of the wheel arch and underneath. Repeat for other side.

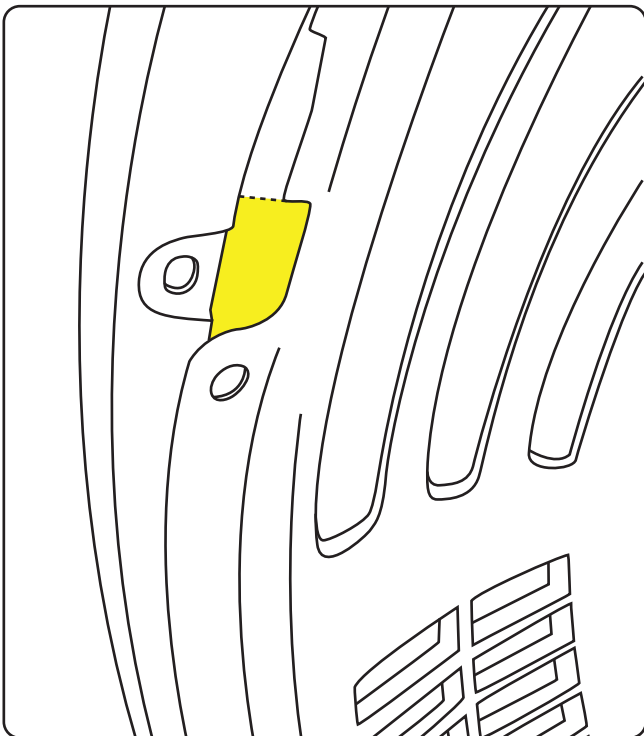
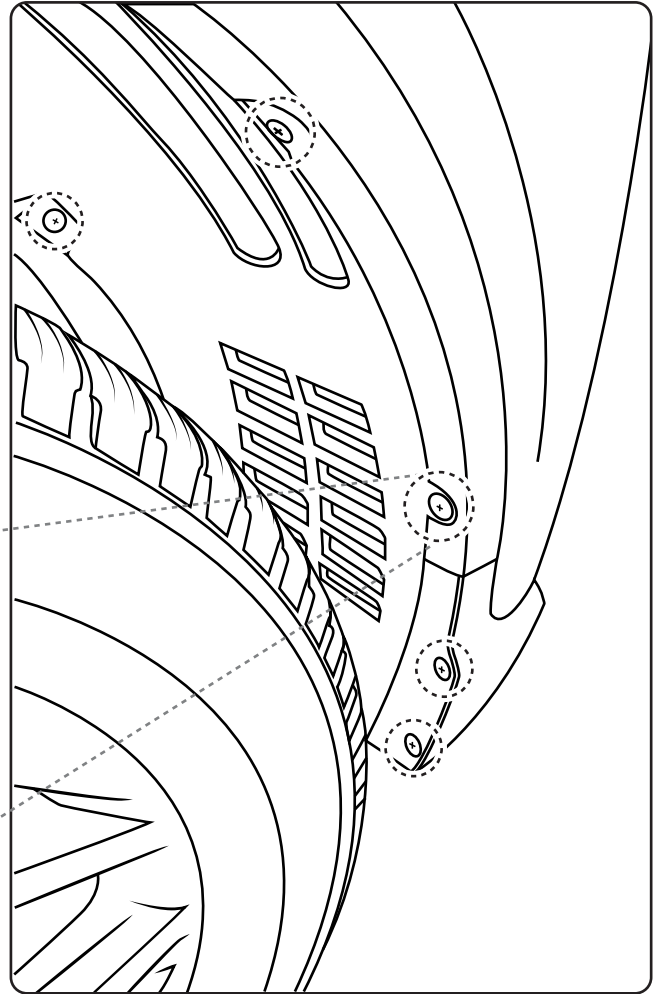
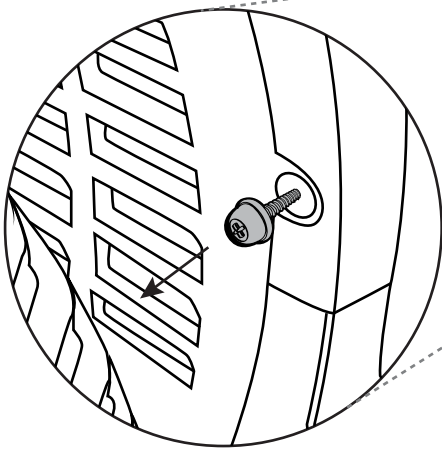

**4.** Locate the hole in the splash guard where the quarter panel and the bumper meet. Using a Philips head, remove the vertically positioned retainer screw. Repeat for other side.

**5.** Remove factory bash plates.



**6.** Once all screws are removed pull bumper off starting from one side. Once bar releases itself, keep close as the wiring harness is still connected. Unclip the front bar wiring loom connection located on the passenger side. Remove the front bar from the front of the car and place on a stand.

**7.** Once bumper bar is removed from the vehicle unclip wiring harness from the bar and set aside.

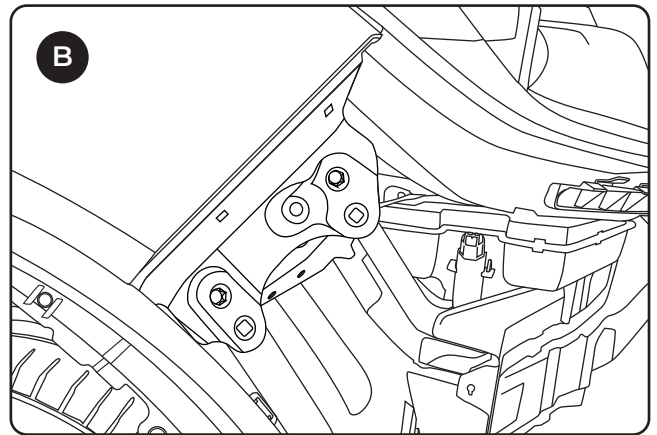
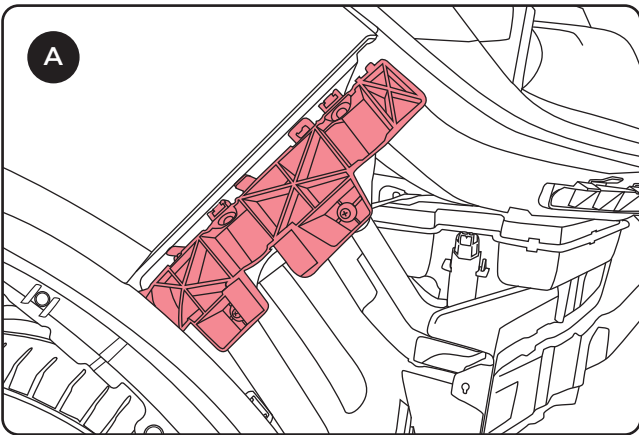

**8.** Using a Phillips head screwdriver remove plastic bumper retaining brackets from the quarter panels on both sides.

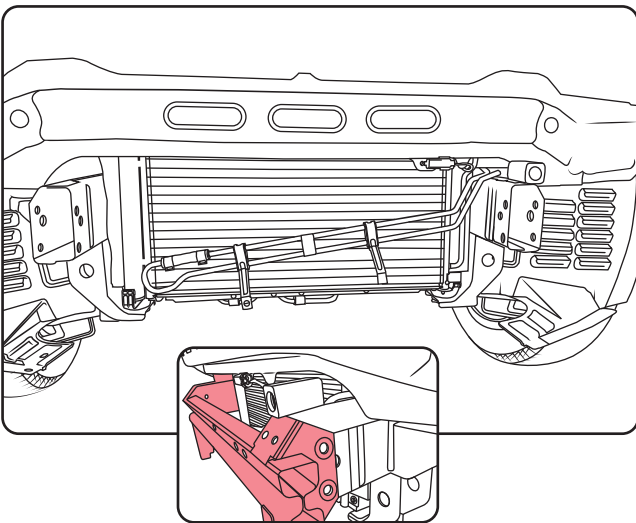

**9.** Unbolt power steering cooler lines from center reinforcement.

**10.** Unbolt and remove center reinforcement.

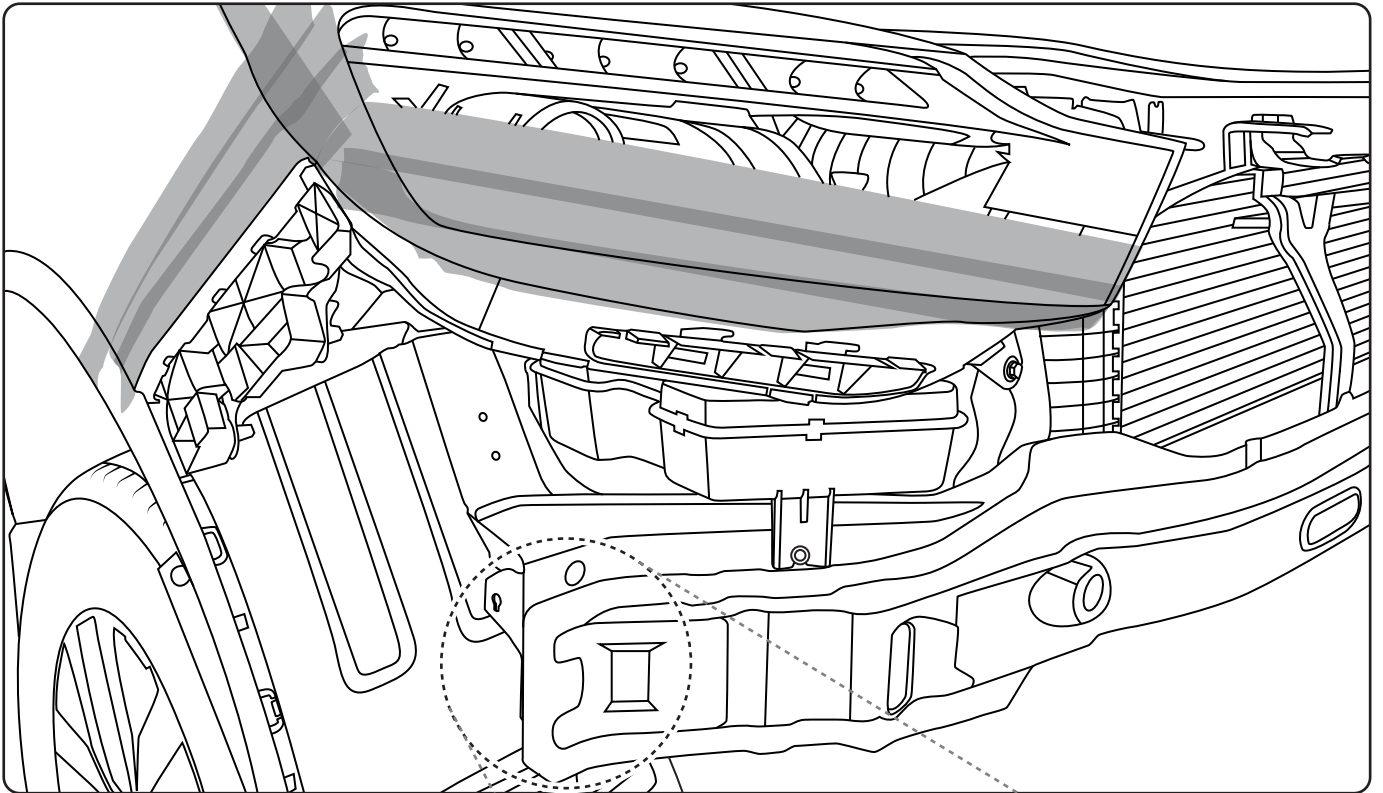

**11.** To prevent any damage during the bar installation, take precautionary measures by taping up the headlights and quarter panels.

**12.** Trim body panel as per photo and cover exposed areas with epoxy based rust resistant paint.

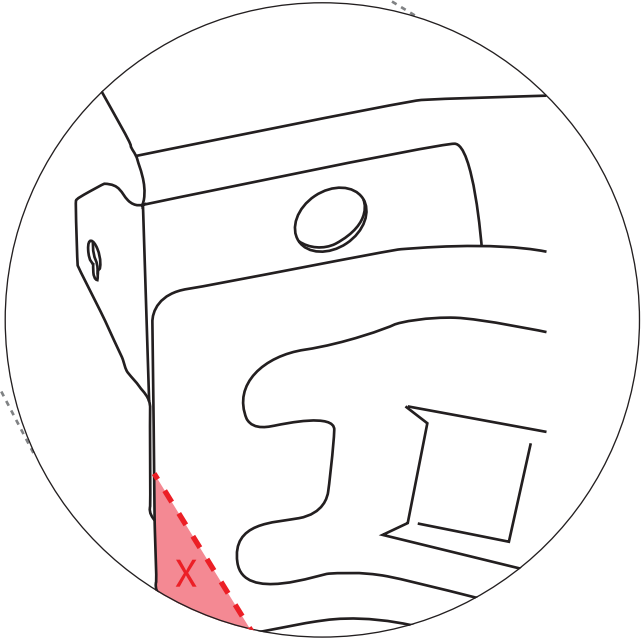

**13.** Remove all 4 sensors from their cradles and set aside.

**14.** Unclip grill from bumper bar and tape up along cut line.

Cut Line - - -

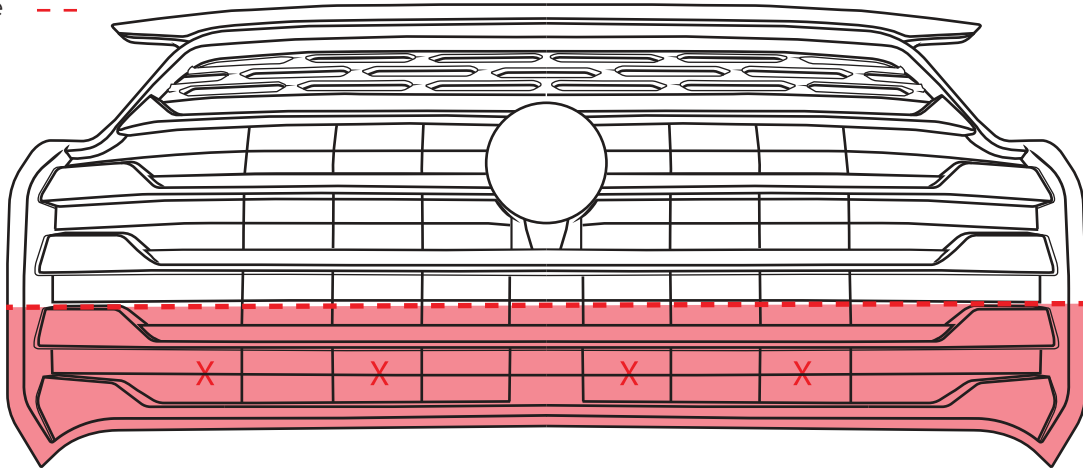

Cut Line - - -

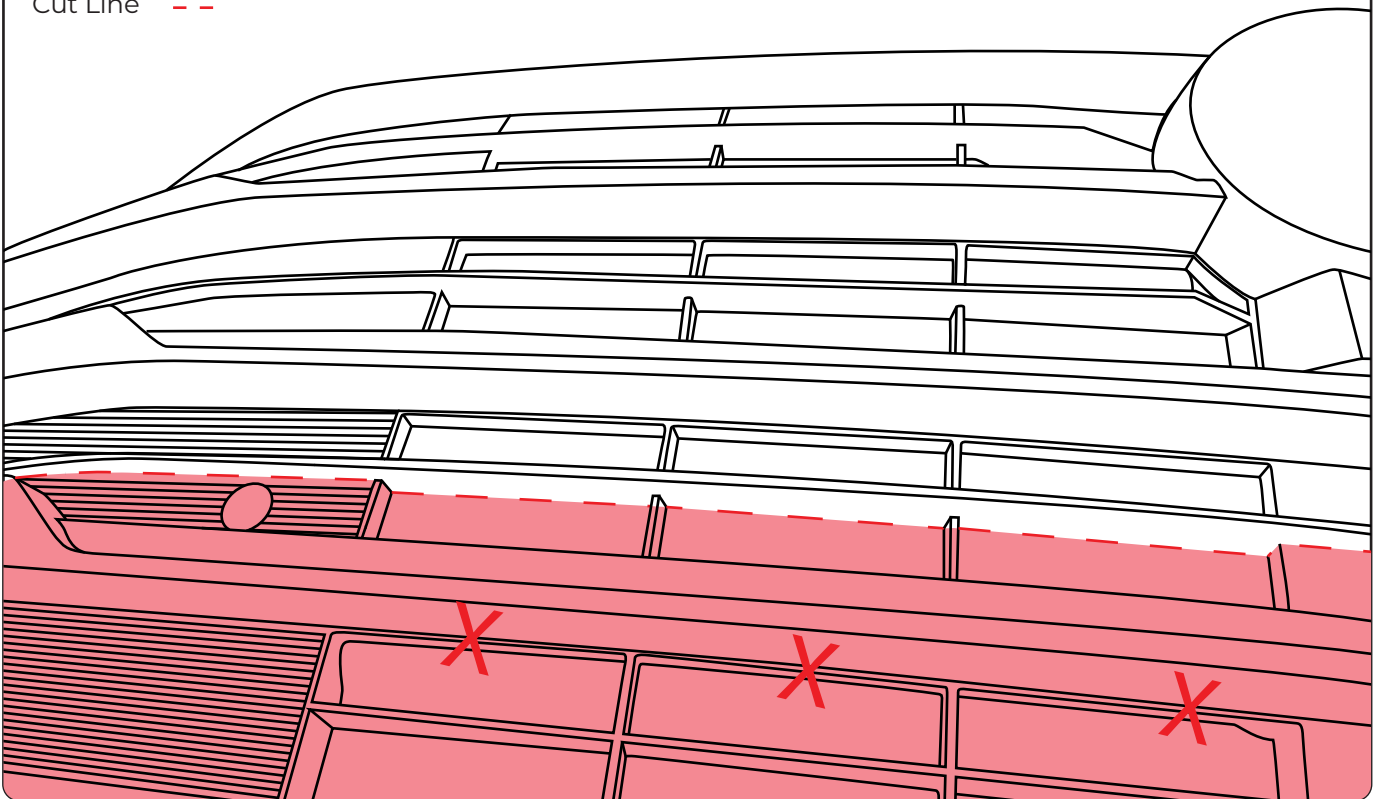

**15.** Cut grill along cut line with air hacksaw and clean up all cut edges.

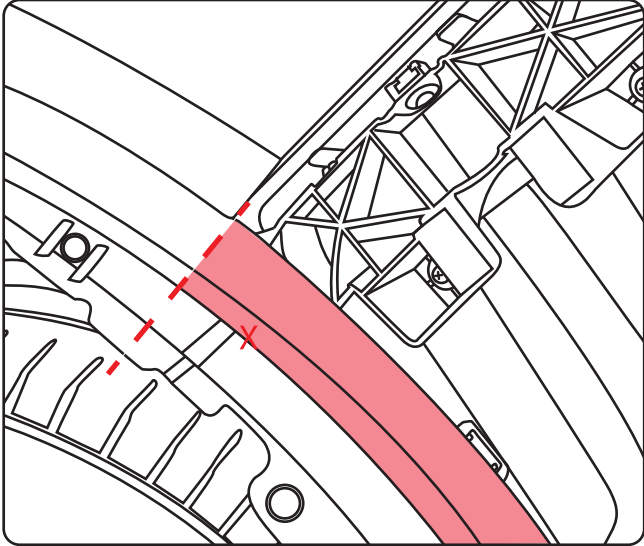

**16.** Tape up plastic wheel arch garnish and trim flush with the end of the quarter panel.



Consider painting the quarter panel and the lower section of the headlights black in order to conceal the gap between the panel and the bumper.

# Part 2

## Bull Bar Preparation

### 1. Affix

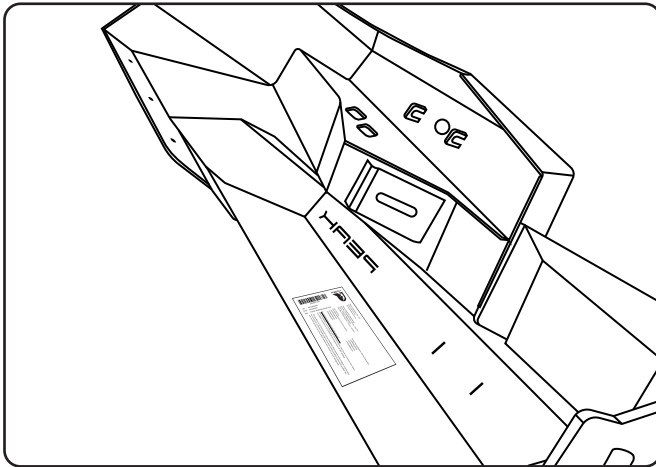

1x Compliance plate on the passenger side bottom panel inside the bull bar. Note serial number and keep for your records.

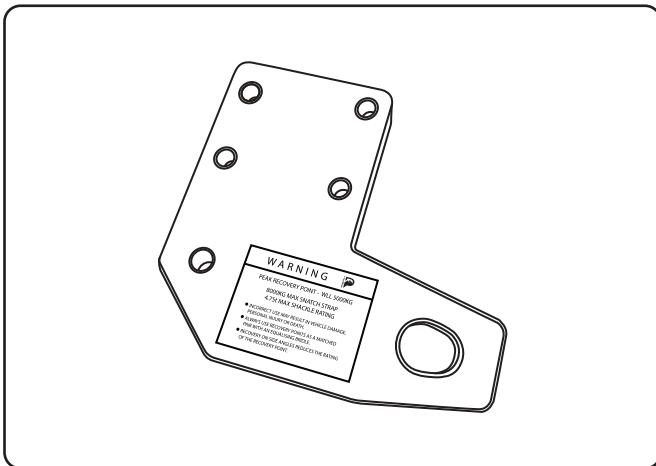

2x recovery point warning labels on the outer side of each recovery point.



Warning will be voided immediately if the compliance plate & two warning labels are not correctly applied and installed in their designated positions.

2. Install STEDI fog lights to bar. Please refer to diagram for correct bolt placement.

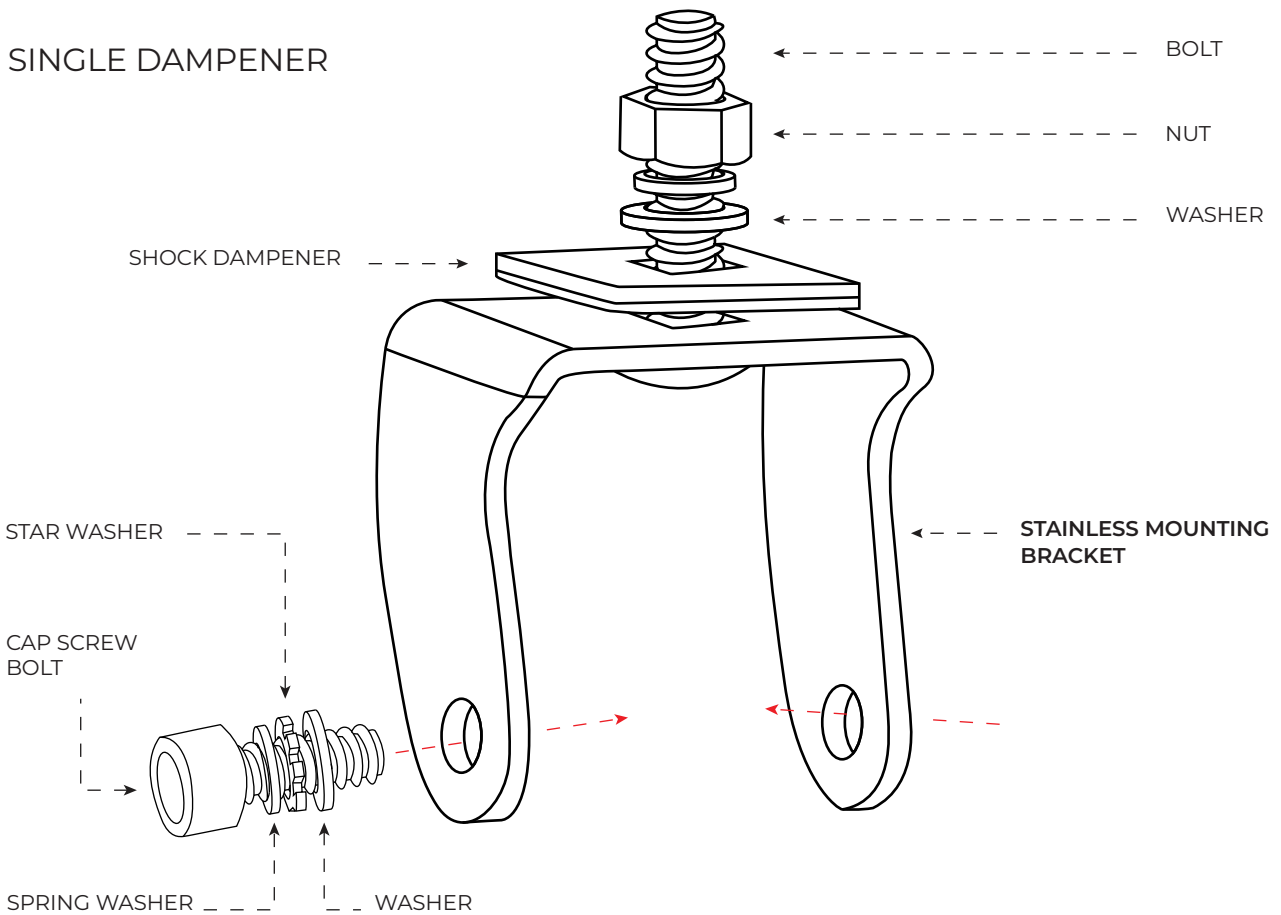

Be sure to face the rubber isolator plate with the rubber facing down.

3. Run factory parking sensor and camera loom.



In case you discover that the sensor wiring is insufficiently long, utilize the provided wire extensions to elongate the inner sensor cable.

4. Using the sensor mounting kit, follow these steps:

- a. Begin by pushing out the centre holes of the base plate. Position the sensor, then secure the backing plate using the supplied screws.

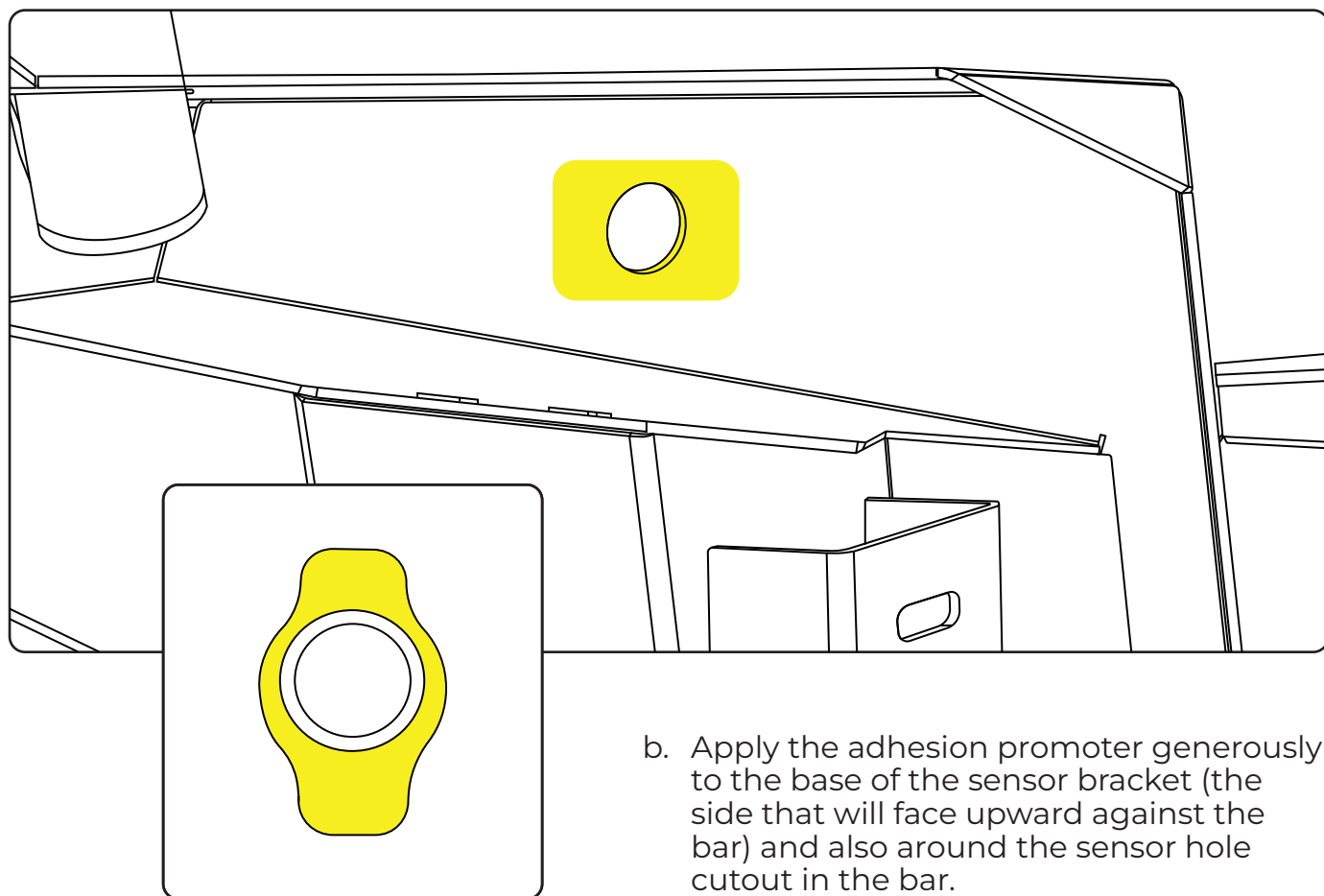
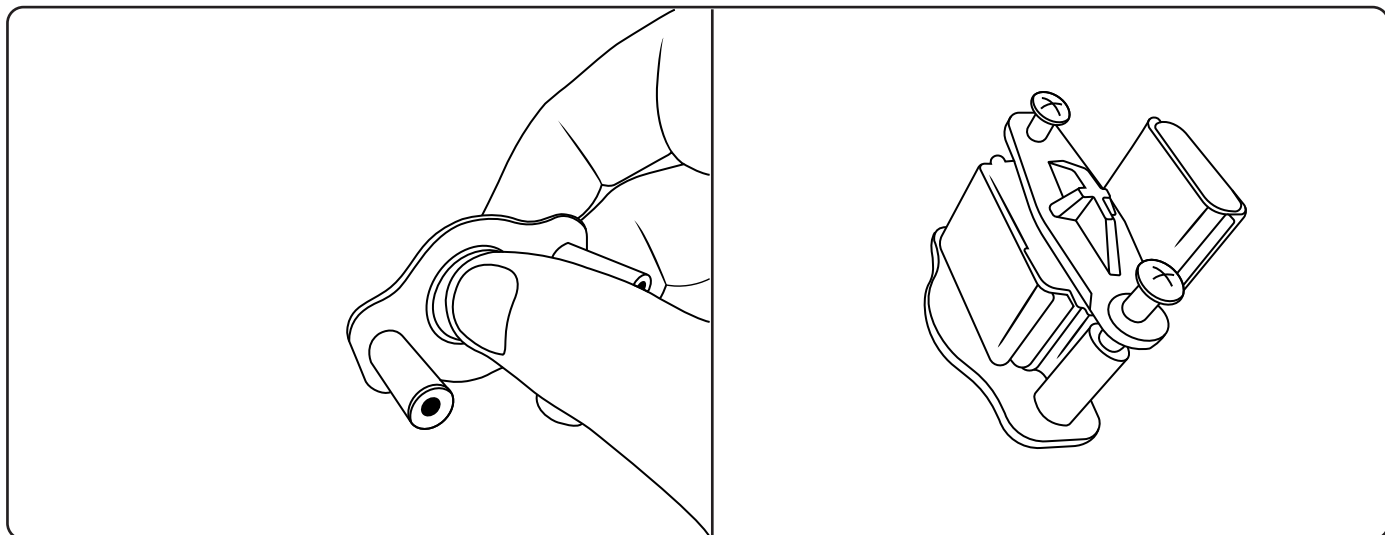

- b. Apply the adhesion promoter generously to the base of the sensor bracket (the side that will face upward against the bar) and also around the sensor hole cutout in the bar.

- c. Affix the double-sided tape to each sensor bracket's base plate.
- d. Firmly place the brackets into position.

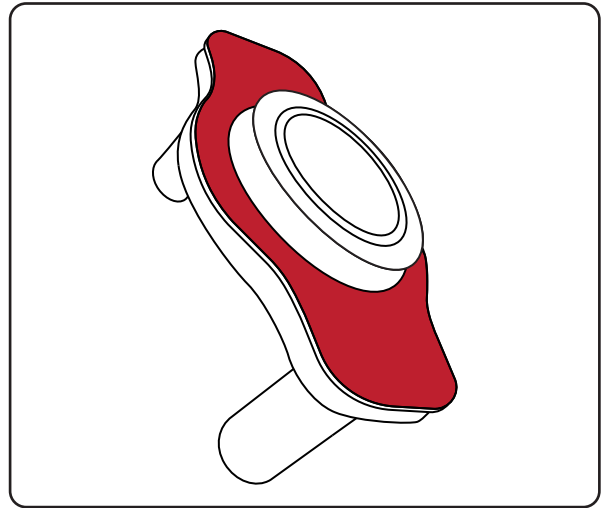

Ensure that the outer sensors have a horizontal orientation, while the inner sensors should have a vertical orientation.

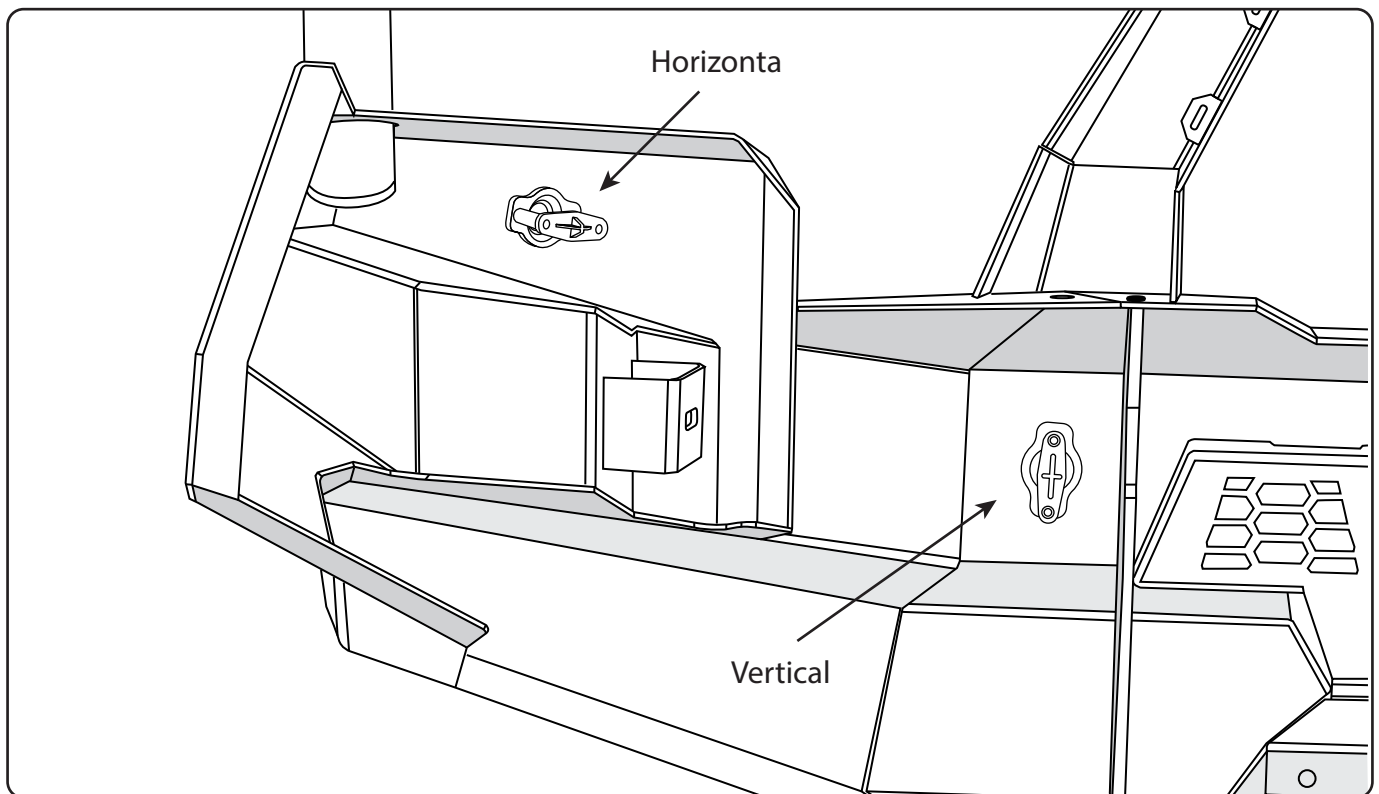



5. Connect wiring harness to each sensor.

6. Using supplied adaptors, connect STEDI lights to the wiring loom (not applicable for factory LED fog lights).

7. Install wing support brackets to bulbar using 1x M10x40mm Nuts bolts and washer.

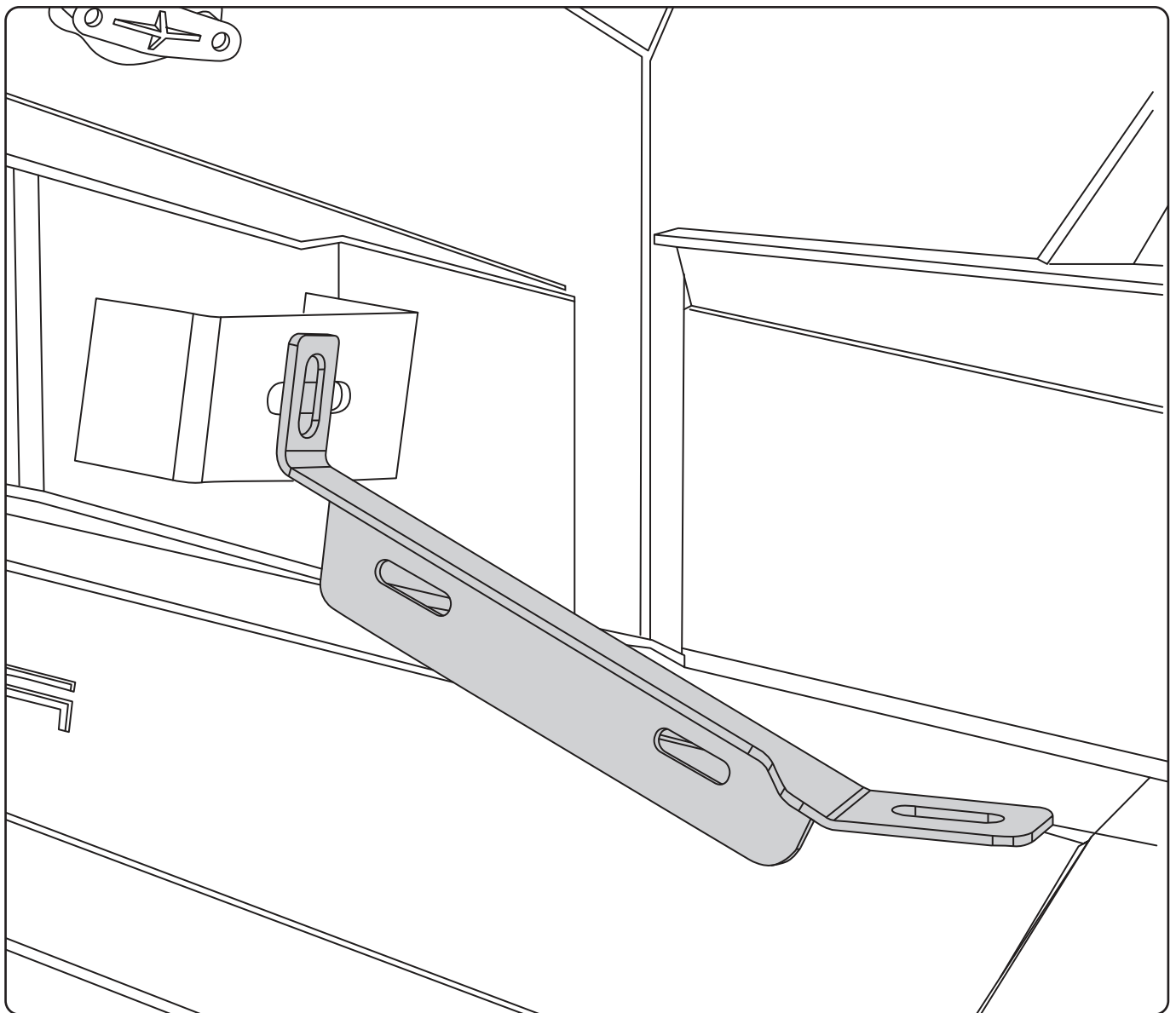

8. Install 2x M6 Cage nuts in centre for number plate bracket. Affix base plate of number plate bracket to bar using 2x M6 bolts.

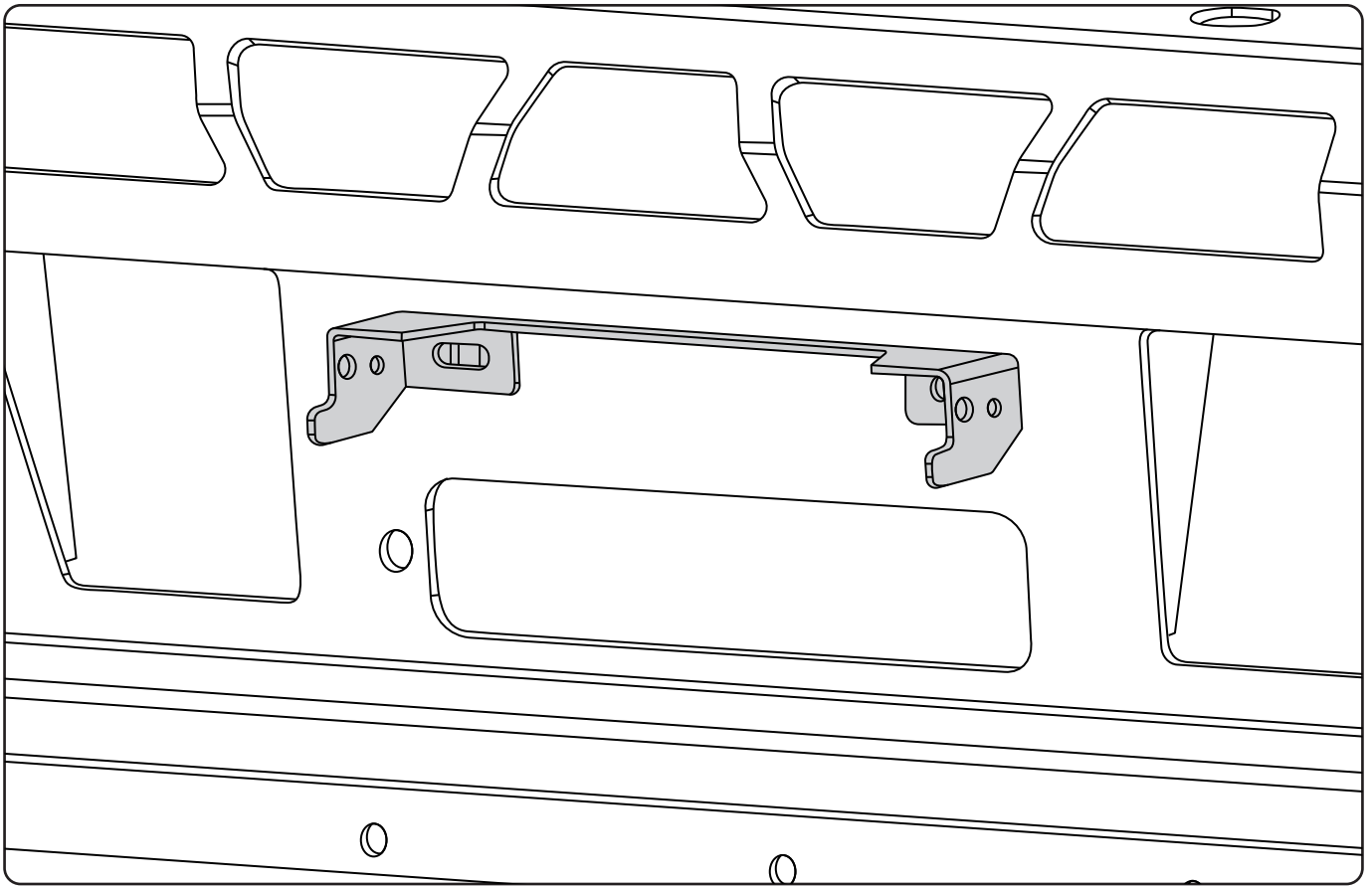

If you plan to install a light bar or spotlights, this is the appropriate moment to do so. In case you're installing both spotlights and a light bar simultaneously, ensure that you trim the spot light bolts, as there is limited clearance available.

# Part 3

## Bull Bar Installation

1. Tape up headlights and quarter panels to prevent damage when installing bar.

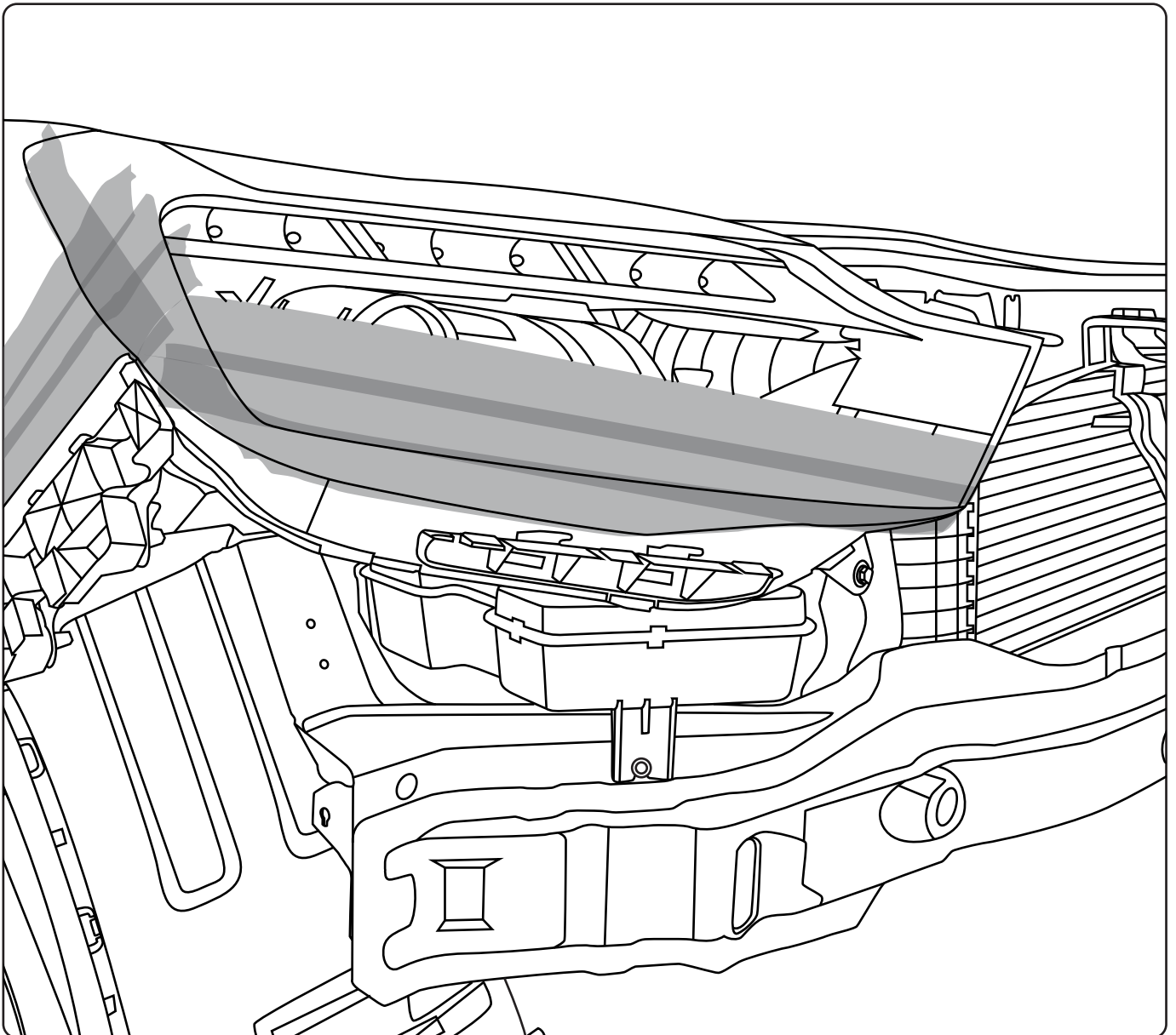

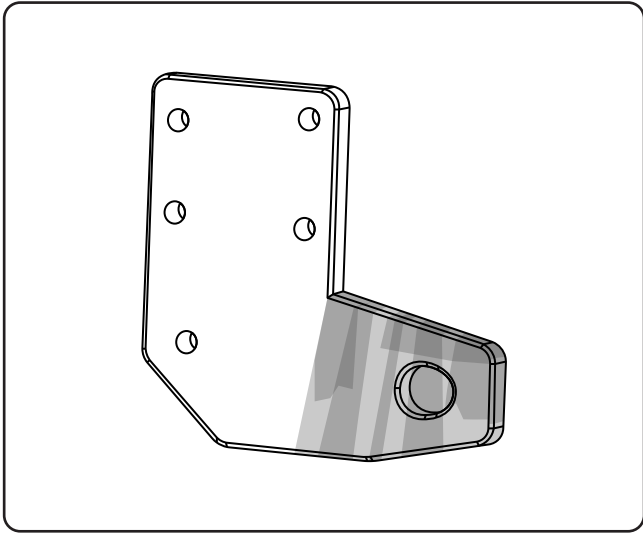

2. Tape up recovery points on chassis mounts before mounting to vehicle.

3. Affix top part of grill bracket to the bottom headlight screw.

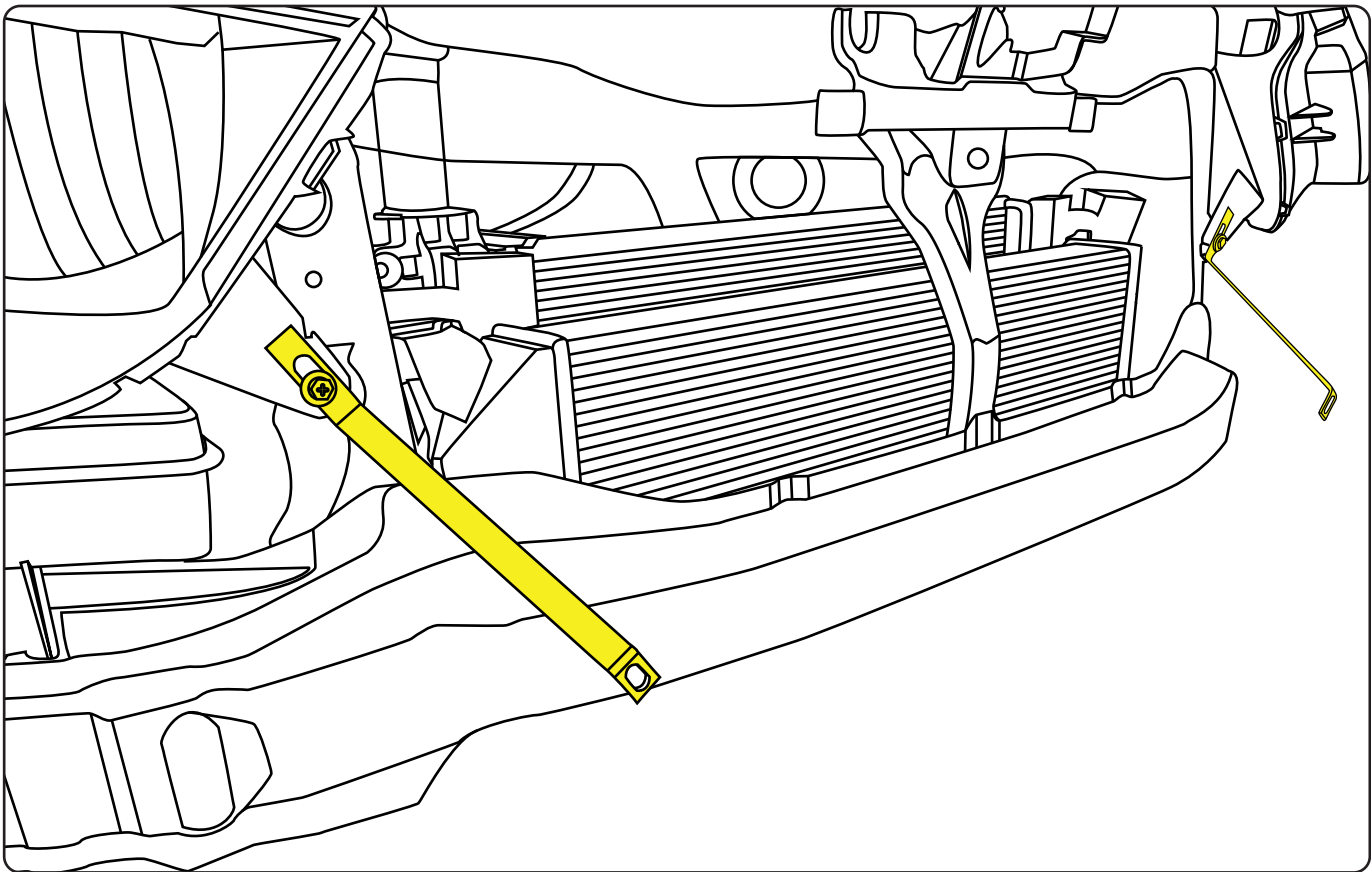

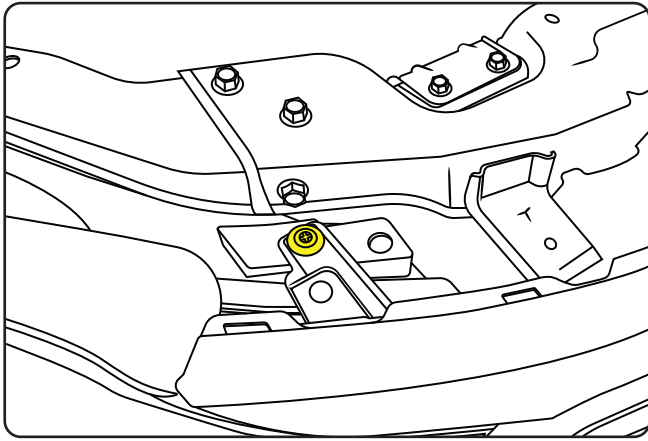

4. Affix grill using 2x domed plastic retainer screw pins sourced from original parts bin.

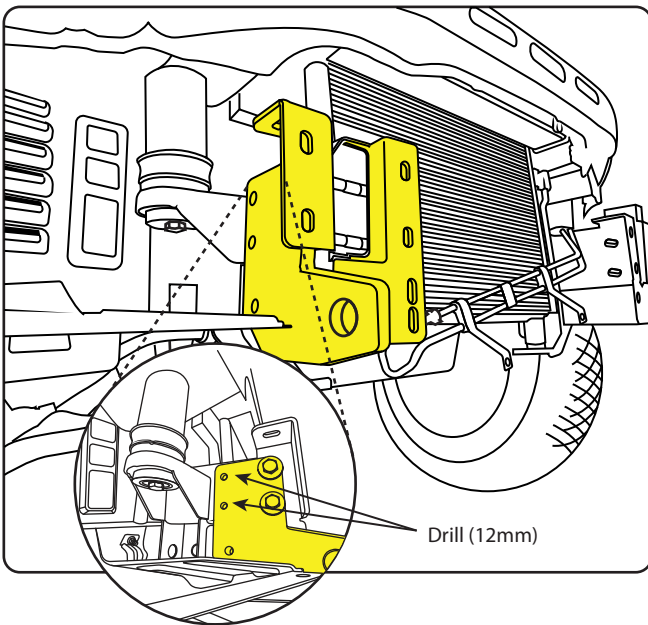

5. Begin by temporarily mounting the chassis brackets using the front two bolts and lower chassis mount point. Mark the locations for the rear bolt holes. Then, remove the chassis bracket and drill holes of 12mm diameter in preparation for the final installation of the chassis bracket and recovery point.

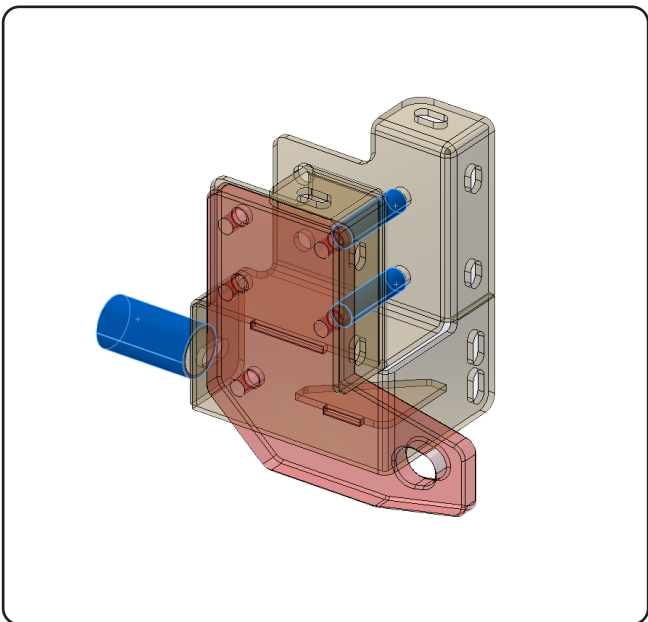

6. Mount 2x chassis mounts & recovery points to front of chassis using 8x M10x120mm bolts, small crush tubes for the front bolts and tighten. Additionally fasten the final lower point using a M10x50mm bolt.

7. Retain lower chassis mount point using supplied large crush tubes and M12x120mm bolts.

8. Install the winch cradle/bar mount to the chassis mount using 12x M10x40mm bolts, nuts and washers.

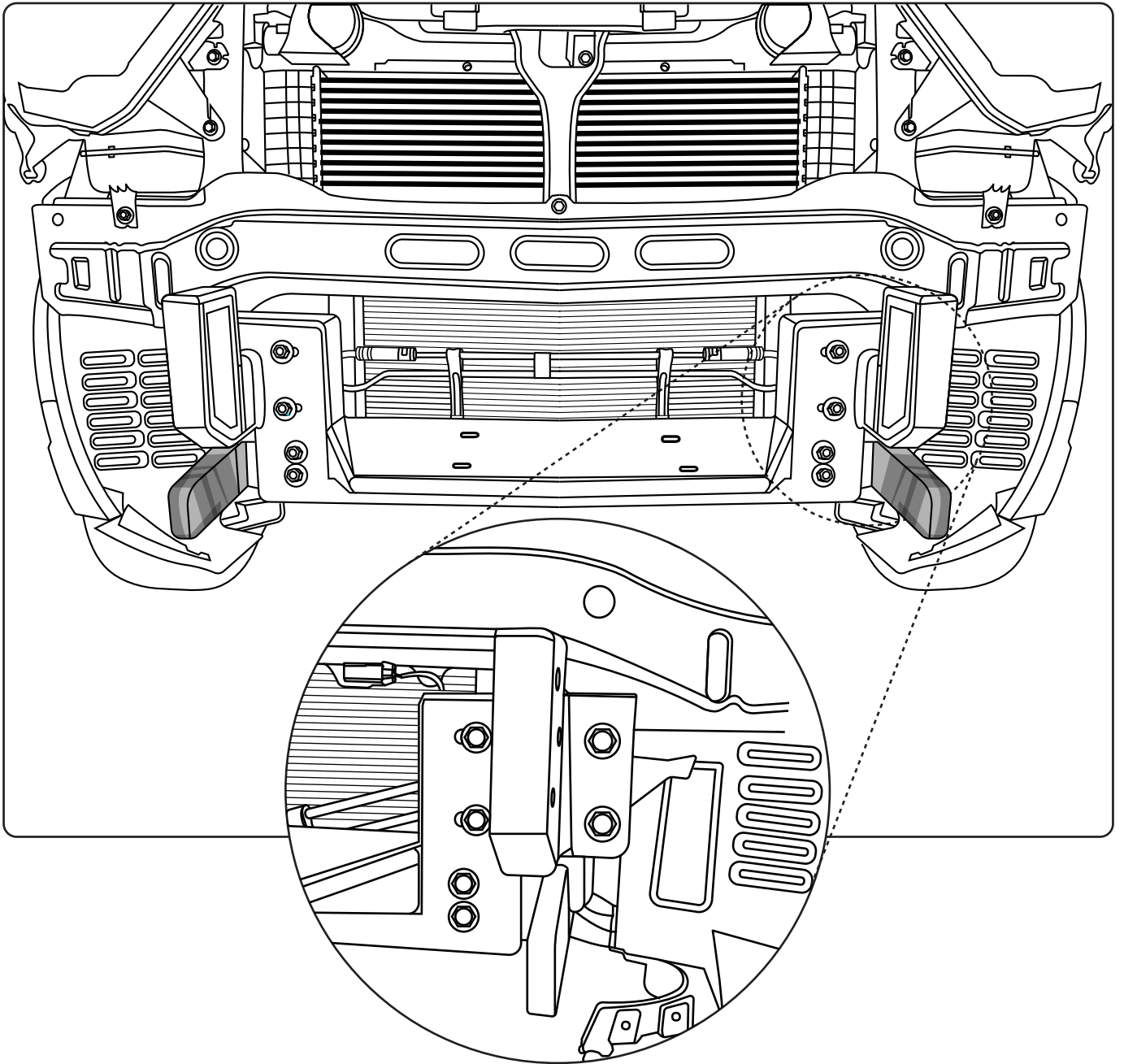

leave these bolts finger tight as cradle might need to be adjusted (Left/Right) once the bar is on.

9. Using the original bolts, affix the power steering cooler lines to the winch cradle using the integrated brackets on the back side of the winch cradle.

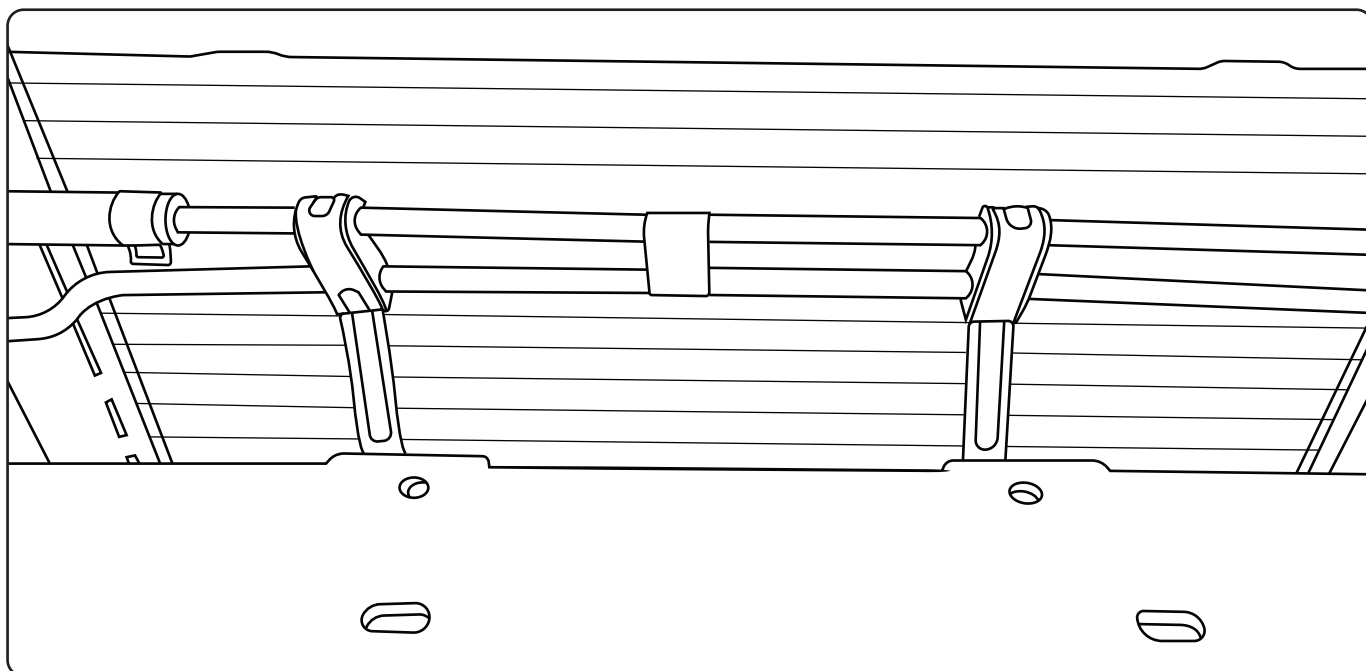

10. With the help of another person slide the bar onto the chassis mount and install 3x M12x40mm bolts, washer and nuts per side to hold the bar in place (pictures below).



As the chassis and the body move independently it is imperative to allow clearance between the bull bar and ANY body mounted parts / faces. Ensure that

- A minimum 25mm gap where the bar meets the quarter panel.
- Adequate clearance from the bar and body mounted parts is retained.

11. Once correct position is achieved tighten all 6 bolts.

**12.** Screw bottom grill bracket to grill mounting point from original inner sensor cradle using 2x Phillips head screws from parts bin.

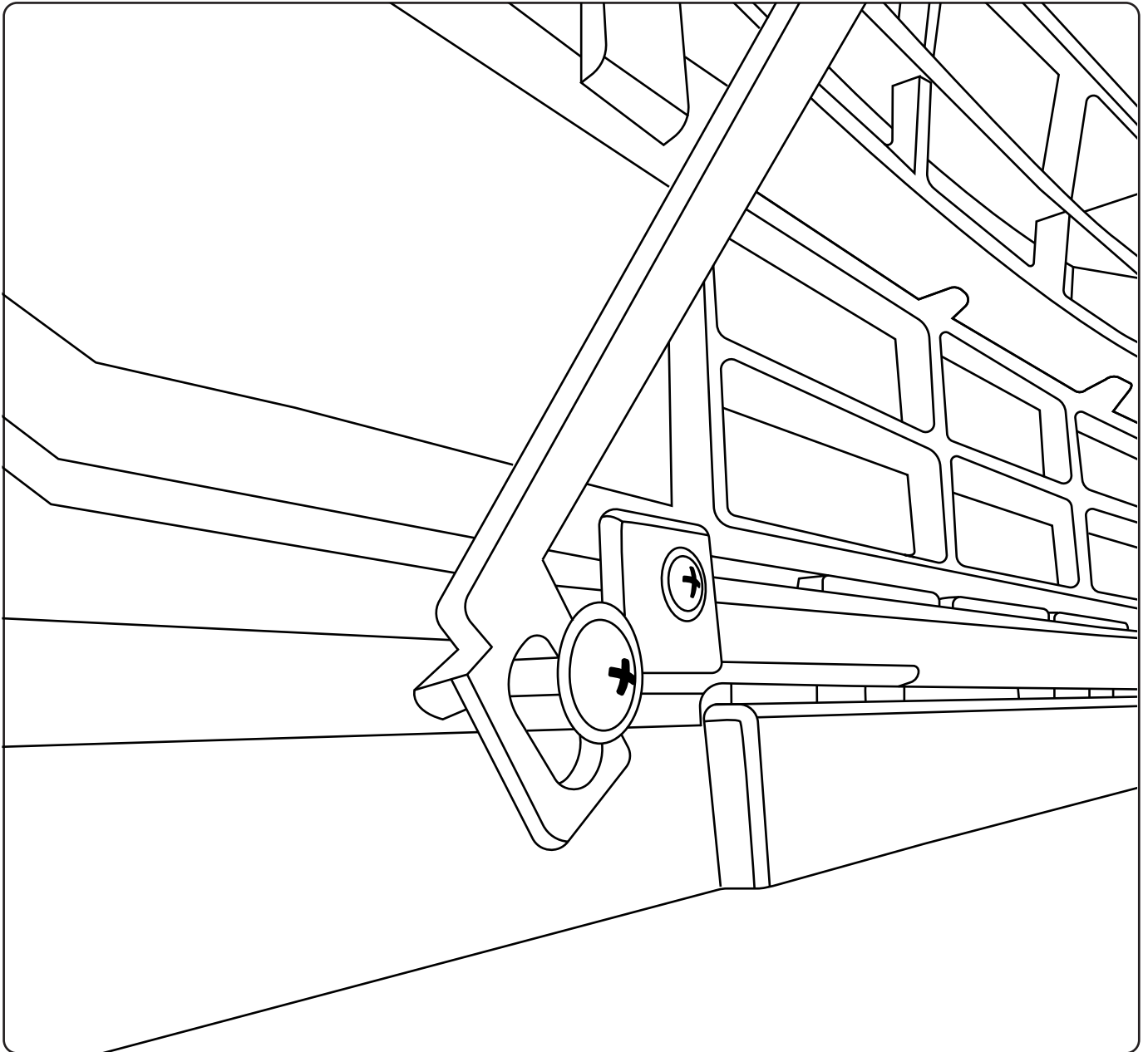



**13.** Mount the other side of wing support bracket to chassis mount using 1x M10x40mm bolts washers & nuts.

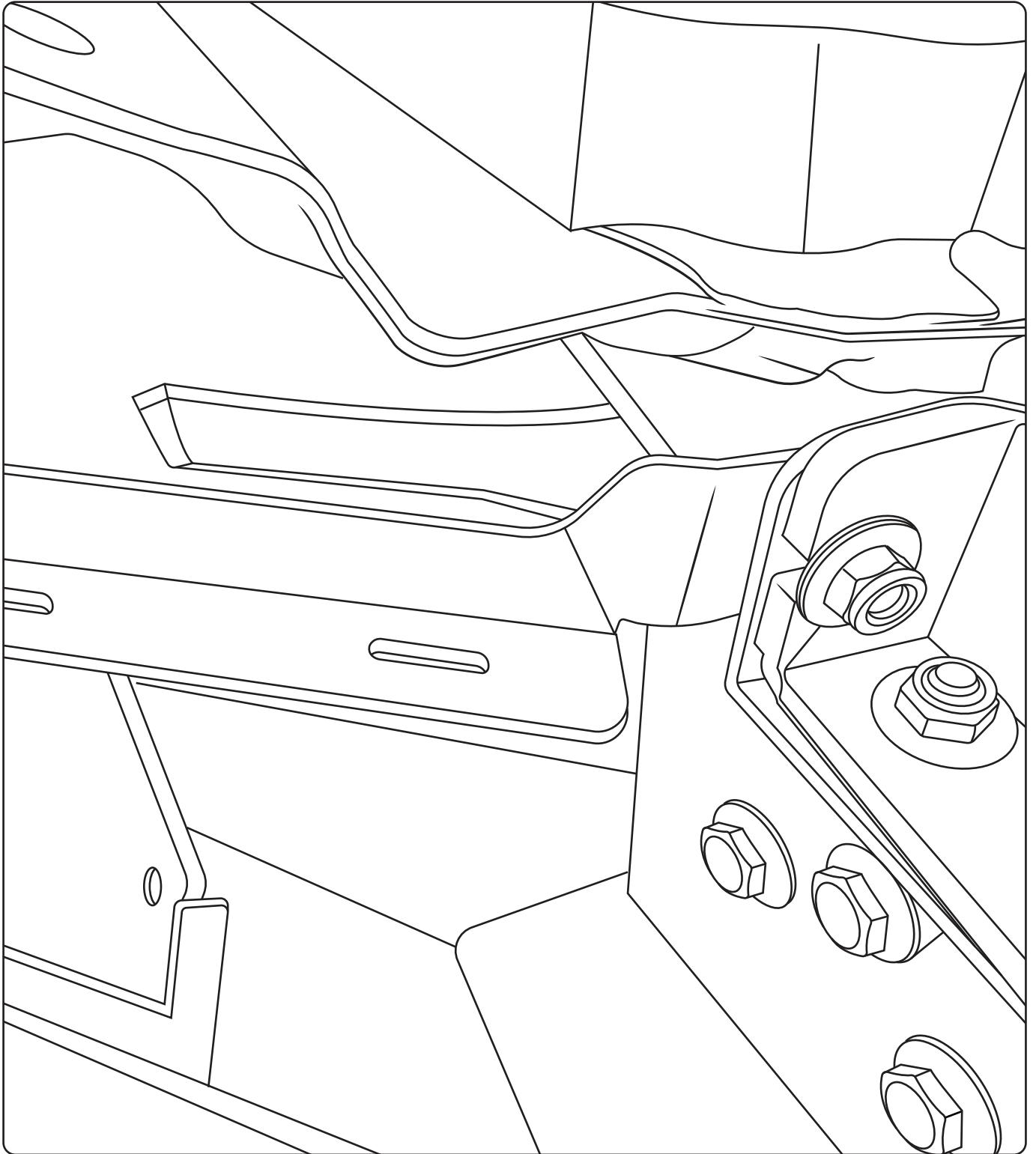

**14.** Enlist the assistance of another individual to securely fasten the three bash plates, beginning at the rear and progressing forward (Bash Plate 03, Bash Plate 02, Bash Plate 01), utilizing the M8x30mm bolts and washers.

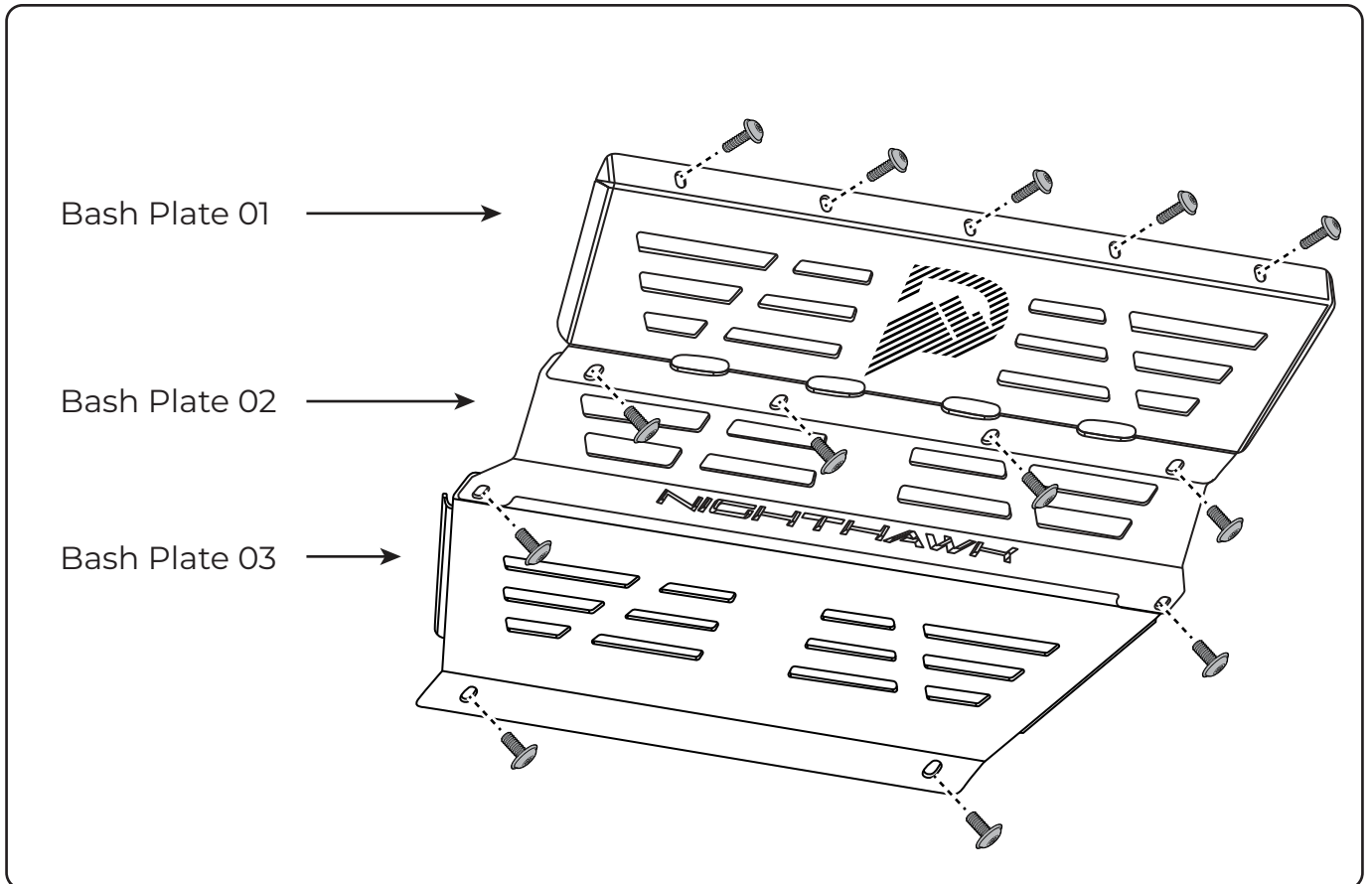

**15.** Plug in camera to wiring loom.

**16.** Plug in the main harness to body.

**17.** Replace front engine cowling.

**18.** Trim the inner guards to suit the profile of the bar, rest inner guard up to bar and trace profile on to the plastic and trim with ait hacksaw or snips.

**19.** Affix top part of number plate bracket using M6 bolts, nuts & washers.

**20.** Test fog lights and sensors.



**M1 Nighthawk by PEAK**

[www.peak4x4.com.au](http://www.peak4x4.com.au) | [info@peak4x4.com.au](mailto:info@peak4x4.com.au)