

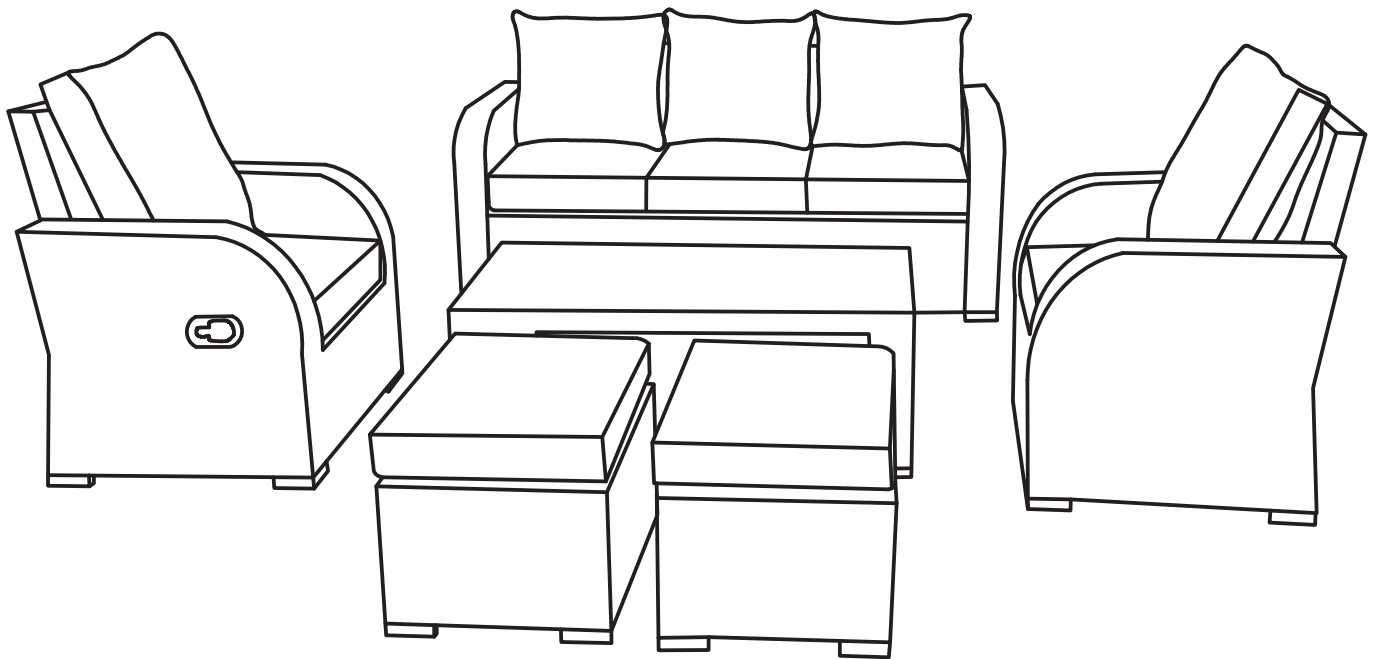

INeda012V01_US_CA





860-105_860-105V70







READ AND SAVE THIS INSTRUCTIONS FOR FUTURE USE

ASSEMBLY & INSTRUCTION MANUAL



BOX-1/4

NO.	PARTS	QTY
A		2
B		2
C		2
T		2
E ↓ O		1



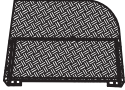

BOX-2/4











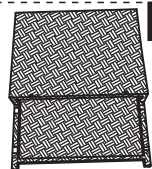
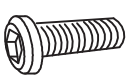

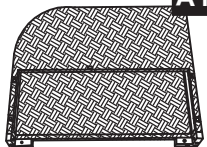
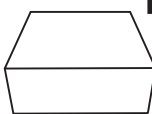
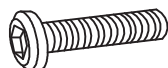
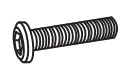
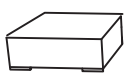
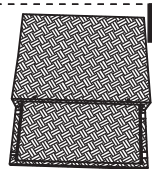

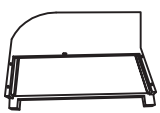



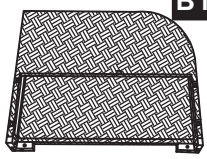



NO.	PARTS	QTY
C1		1
D1		2
E1		1
F1		2
V		3

BOX-3/4

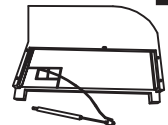
NO.	PARTS	QTY
A1		1
B1		1
D		2
W		3

BOX-3/4

NO.	PARTS	QTY
A2		2
B2		1
U		2
X		2

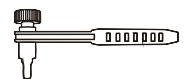
 A x 2	 C1 x 1	 H x 4 M8*40	 O x 3
 A1 x 1	 D x 2	 I x 4 M8*65	 S x 2 M6*50
 A2 x 2	 D1 x 2	 J x 74 M6	 T x 2
 B x 2	 E x 4 M6	 K x 36	 U x 2
 B1 x 1	 E1 x 1 M8	 L x 16	 V x 3
 B2 x 1	 F x 8 M6*50	 L1 x 18 M6*55	 W x 3
 C x 2	 F1 x 2 M8	 M x 8	 X x 2
	 G x 10 M6*60	 N x 3	 Y x 1

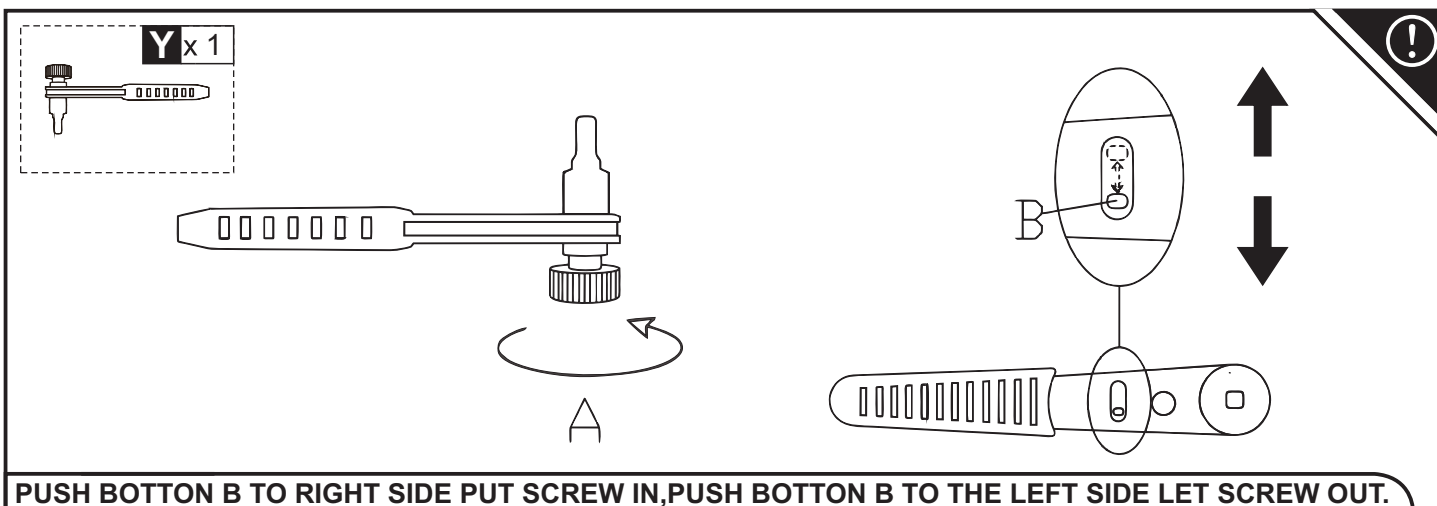

PUSH BOTTON B TO RIGHT SIDE PUT SCREW IN, PUSH BOTTON B TO THE LEFT SIDE LET SCREW OUT.

F x 2

G x 1

J x 6

K x 3

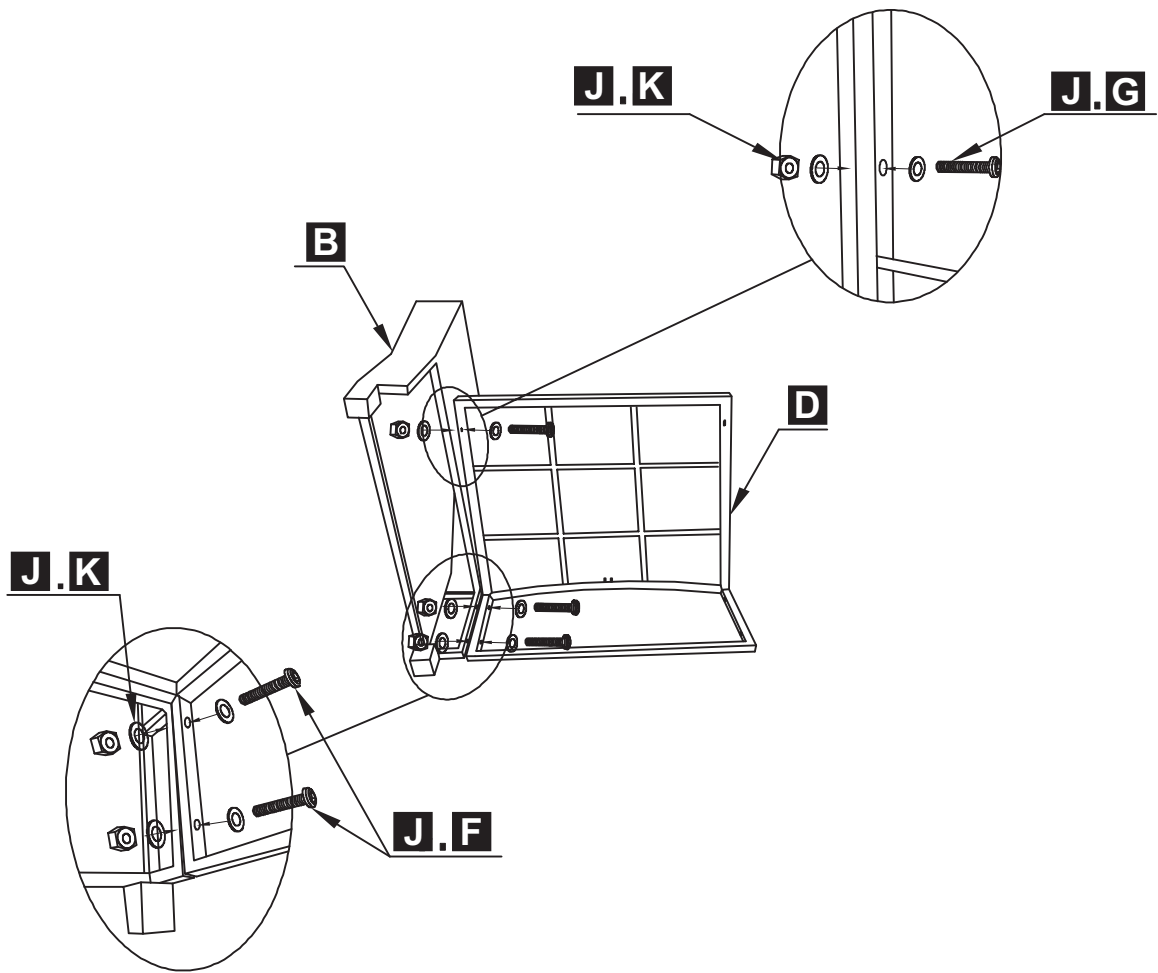

x2

F x 2

G x 1

J x 6

K x 3

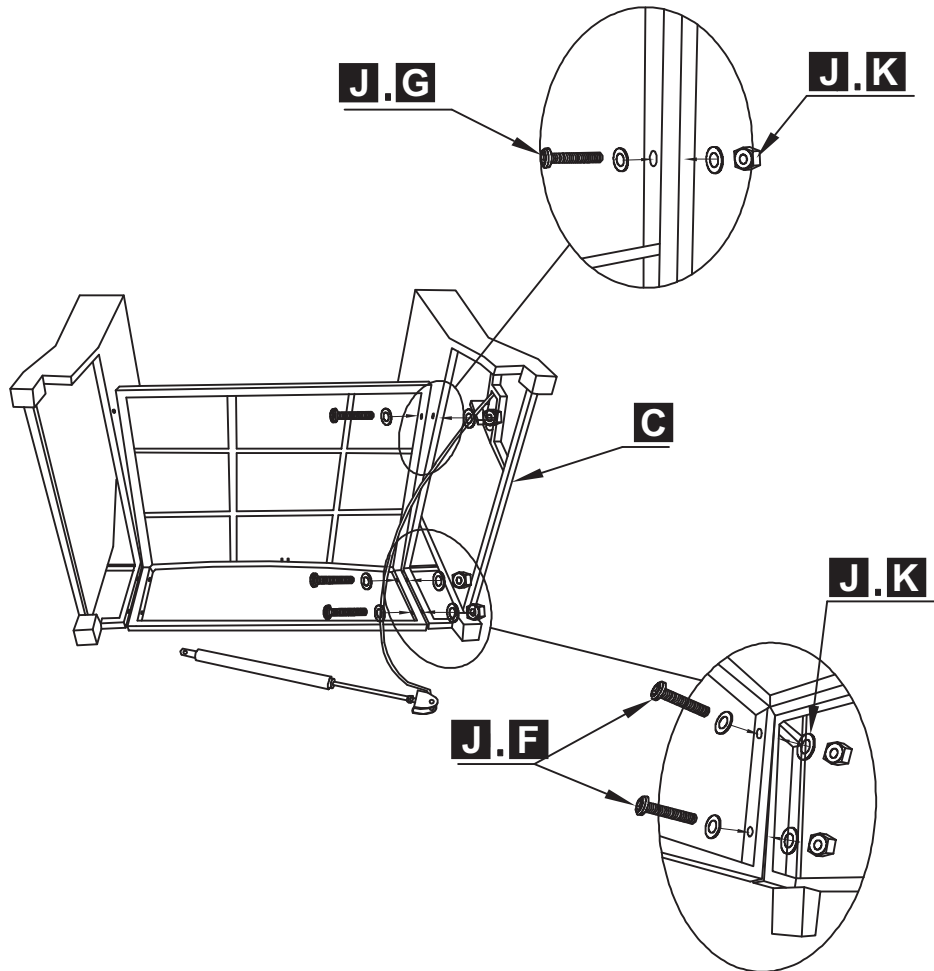

x2

I x 2

L x 4

M x 2

E x 2

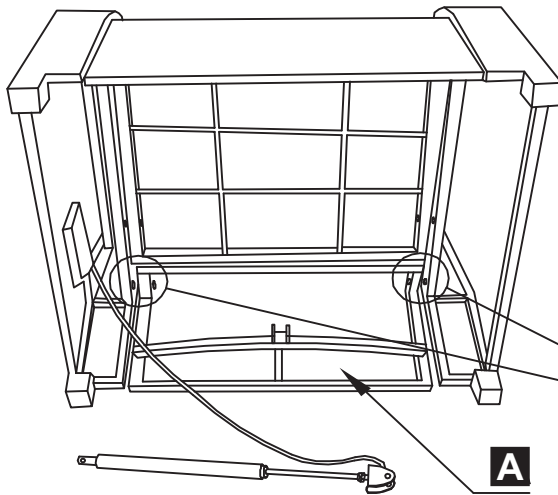

I.M

L.O

E

x2

H x 2

L x 4

M x 2

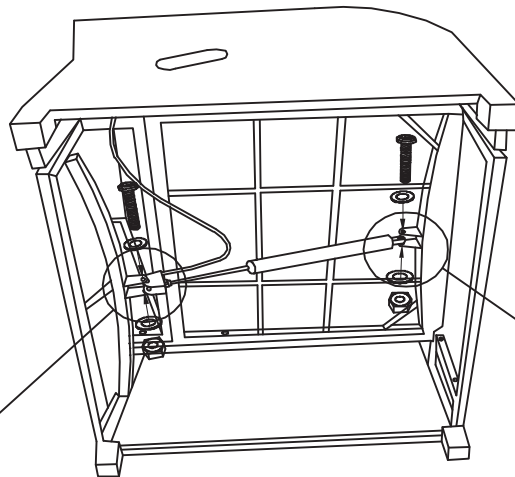

L.H

L.H

L.M

L.M

x2

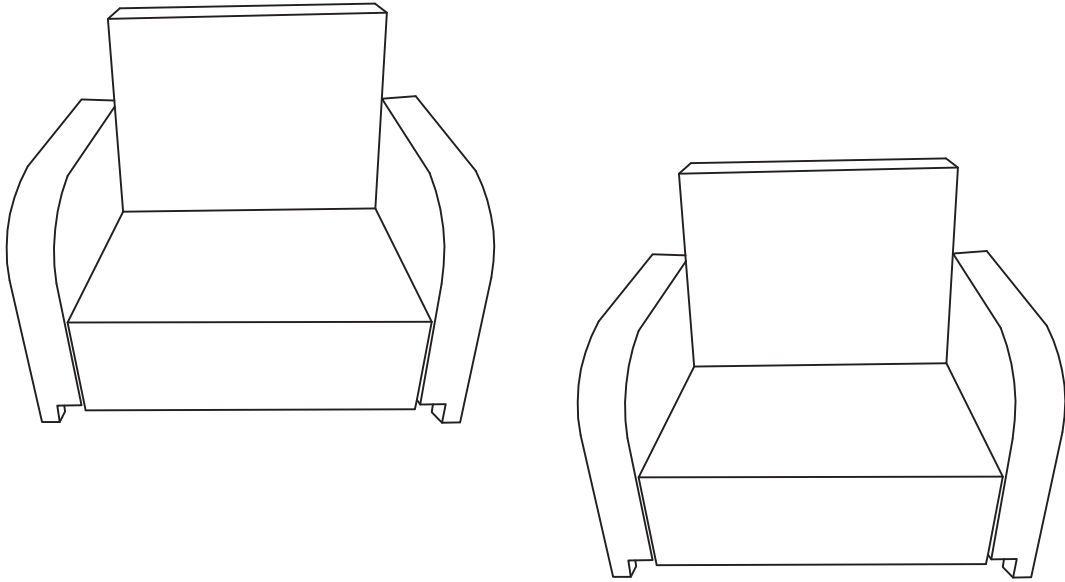

G x 2

L1 . J

J . K

E1

L1 x 4

J x 12

K x 6

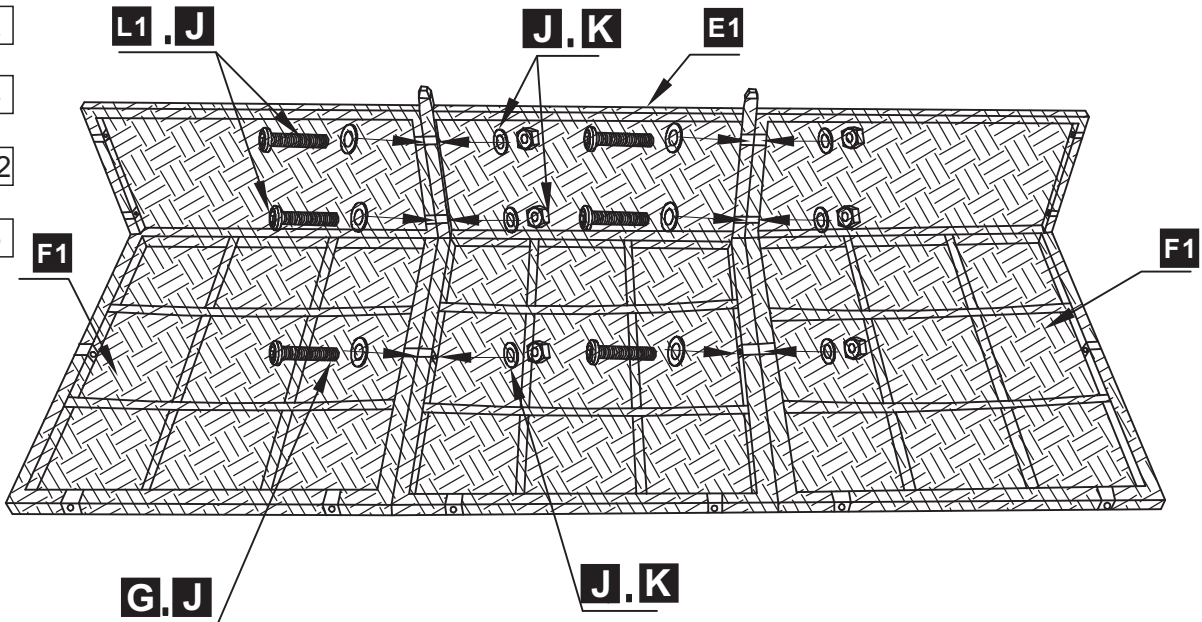

G . J

J . K

G x 4

D1

C1

D1

J x 8

K x 4

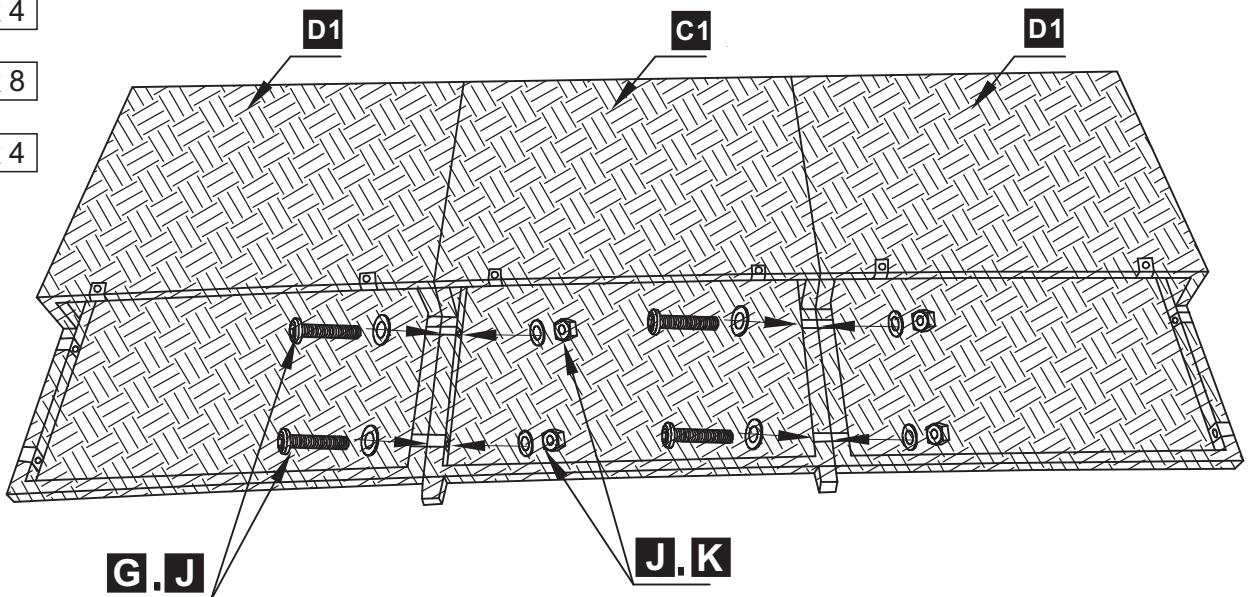

G . J

J . K

L1 x 6

J x 12

K x 6

L1 . J

E1

F1

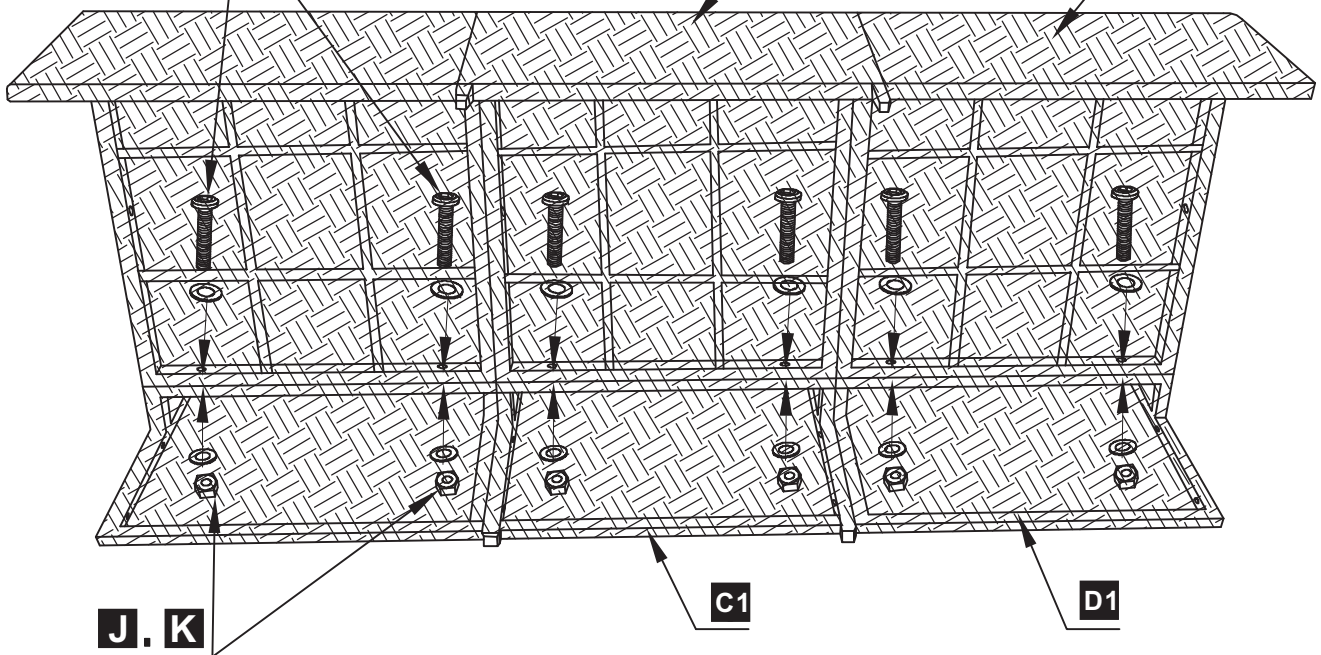

J . K

C1

D1

L1 x 8

J x 18

K x 8

S x 2

A1

B1

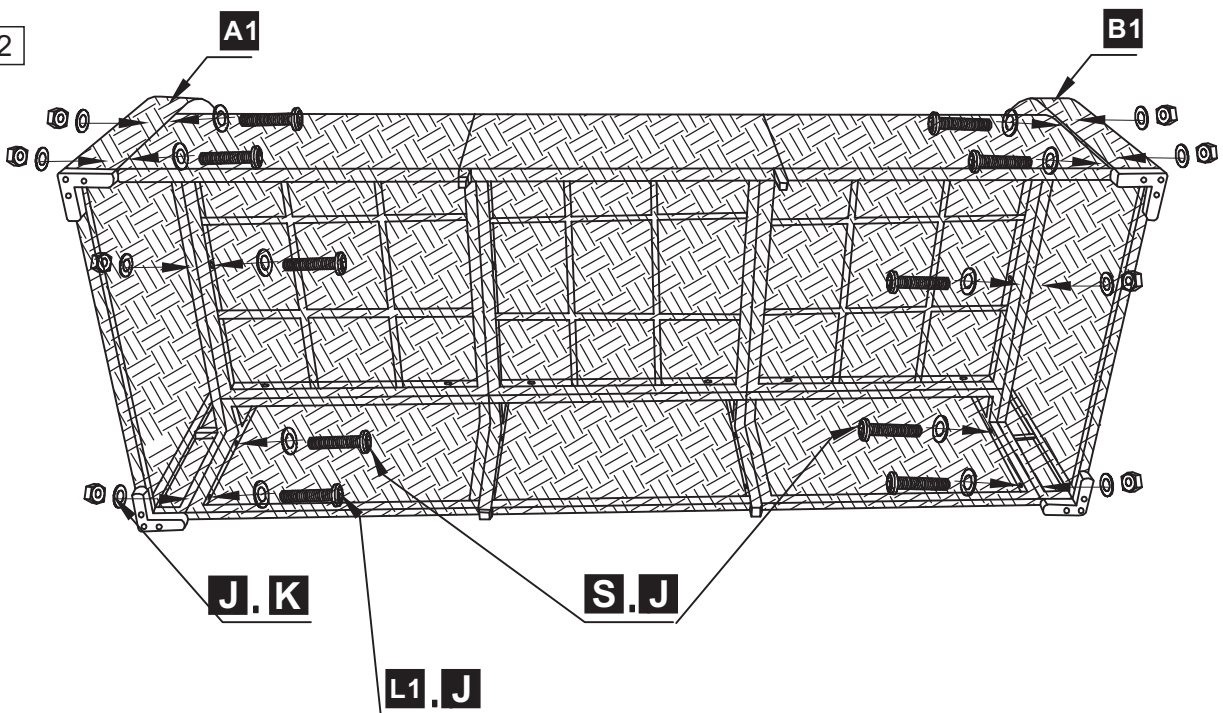

J . K

S . J

L1 . J

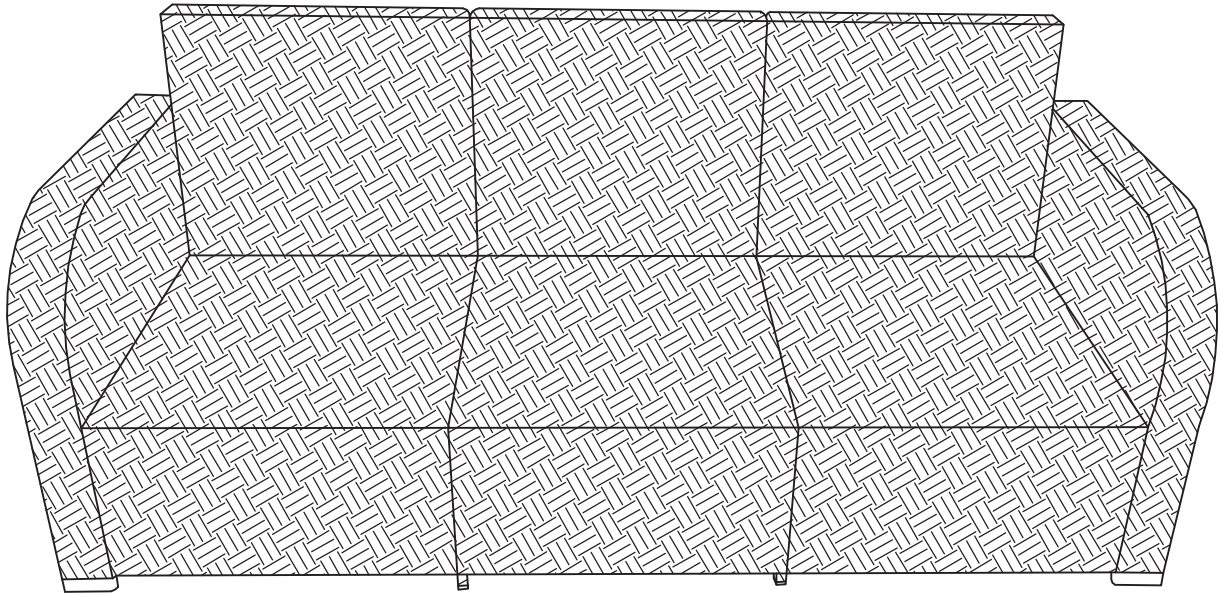

A2x2 **B2x1** **Tx2** **Ux2** **Vx3** **Wx3** **Xx2**

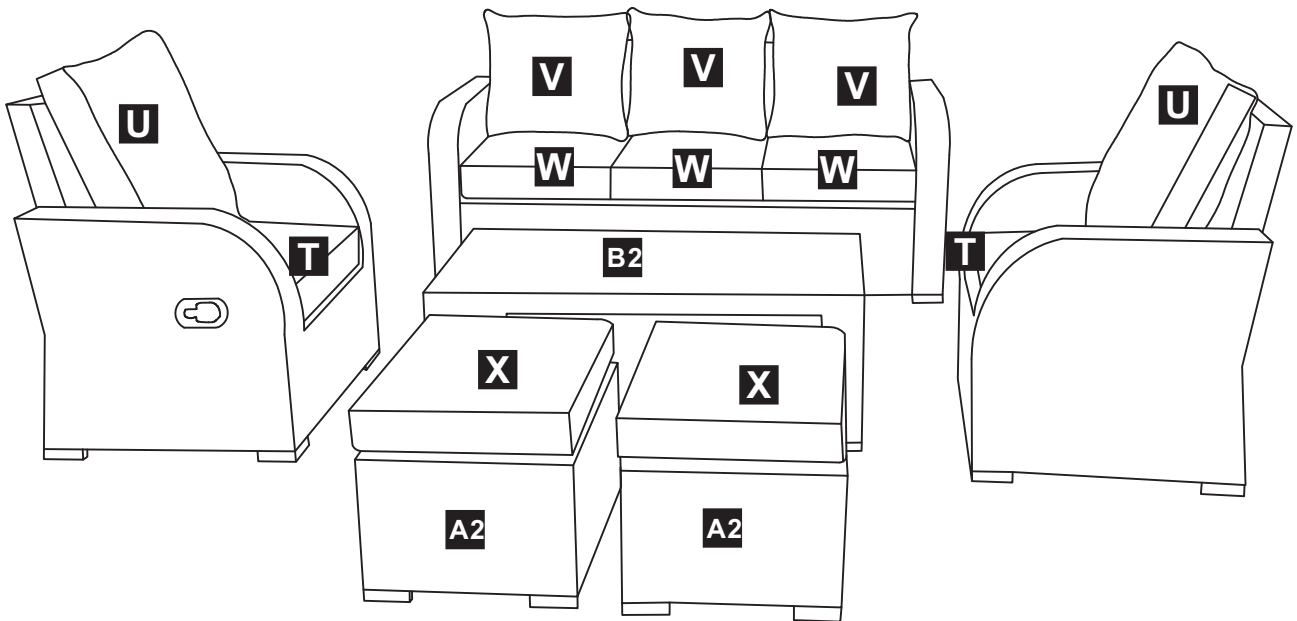

US



001-877-644-9366
customerservice@aosom.com

CA



001-855-537-6088
customerservice@aosom.ca

UK



0044-800-240-4004
enquiries@mhstar.co.uk

DE



0049-(0)40-88307530
service@aosom.de

FR



0033-1-84166106
contact@aosom.fr

ES



0034-931294512
atencioncliente@aosom.es

IT



0039-0249471447
clienti@aosom.it