

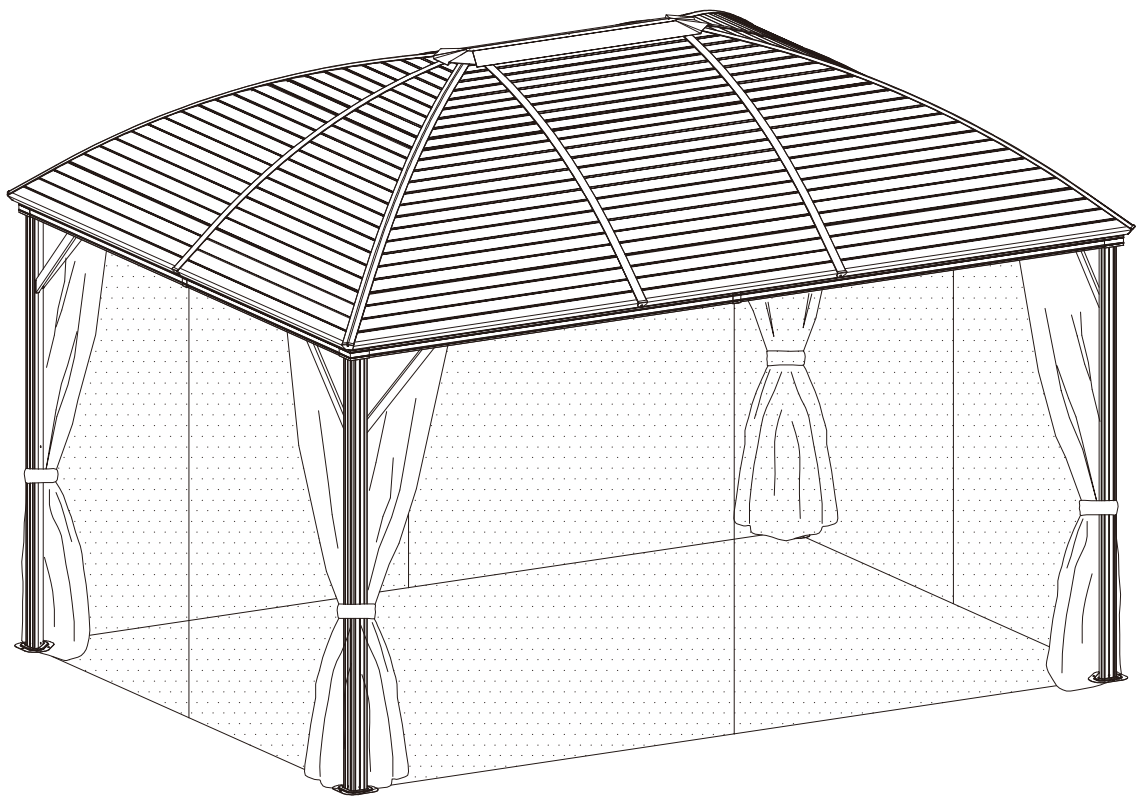

INbed009V01\_GL

84C-097



REQUIRED TOOLS

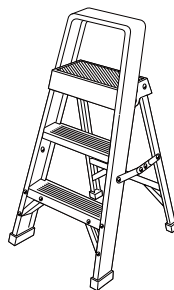
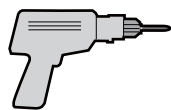

Assembly video please scan the QR code .

READ AND SAVE THIS INSTRUCTION FOR FUTURE USE

ASSEMBLY INSTRUCTION



(A) 4x



(B) 2x



(B1) 2x



(C) 2x



(C1) 2x

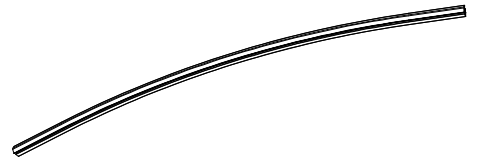

(D) 4x

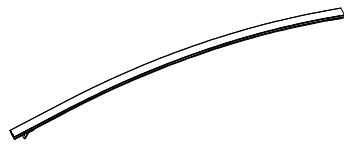

(E) 6x



(F) 2x



(F1) 8x



(G) 2x



(G1) 4x



(G2) 4x



(H1) 4x

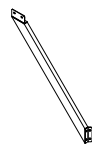

(H2) 4x

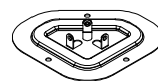

(J) 4x

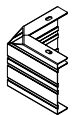

(K) 4x



(K1) 4x

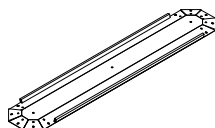



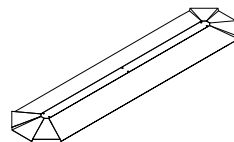







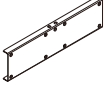
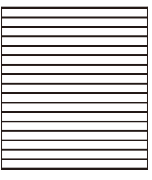
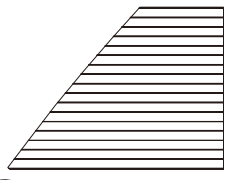
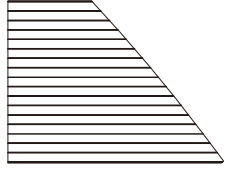

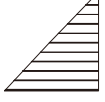
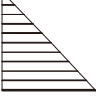
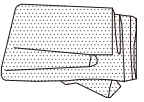
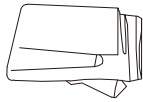



(L) 1x

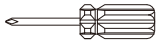

(M) 1x



(N) 4x

 <b>(N1)</b> 6x	 <b>(P)</b> 4x	 <b>(Q)</b> 2x	 <b>(Q1)</b> 4x
 <b>(Q2)</b> 4x	 <b>(R)</b> 2x	 <b>(R1)</b> 4x	 <b>(R2)</b> 4x
 <b>(S)</b> 4x	 <b>(T)</b> 4x	 <b>(U)</b> 112x	 <b>(V)</b> 4x
 <b>(W)</b> 4x	 <b>(W1)</b> 6x	 <b>(Y)</b> 20x	 <b>(Z1)</b> 12x
<b>S4</b>  1x	 1x		
 <b>M6x15</b> <b>(1)</b> 113x + 4	 <b>M6x10</b> <b>(2)</b> 32x + 1	 <b>M5x12</b> <b>(3)</b> 48x + 2	 <b>ST4.8x12</b> <b>(4)</b> 24x + 2
 <b>(5)</b> 2x	 <b>(8)</b> 12x		

<1>

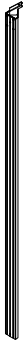

A 4x

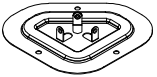



J 4x

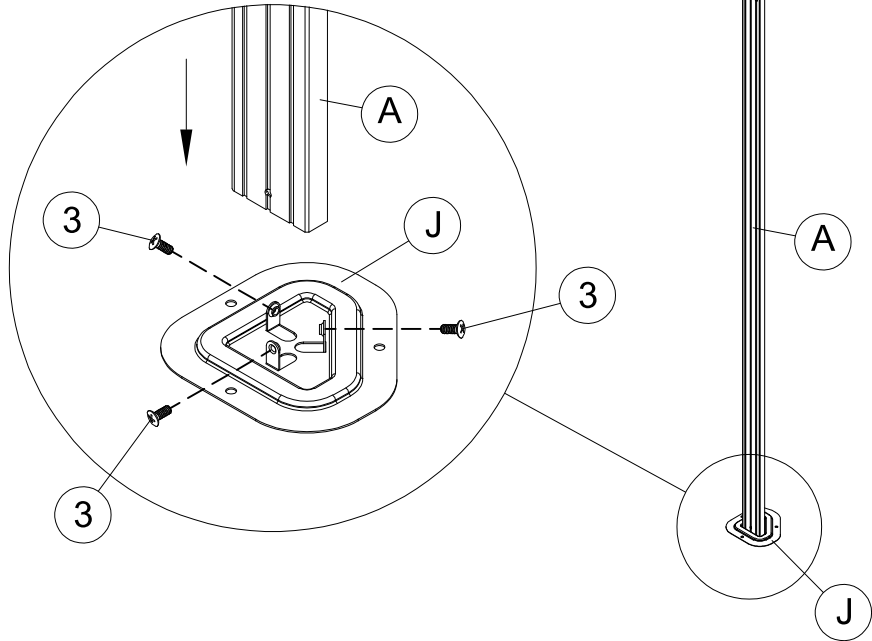

3 12x M5x12

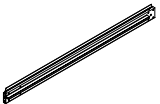
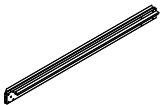
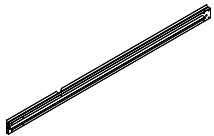
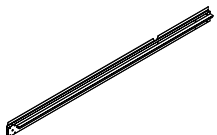
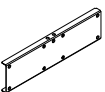

4

-  **B** 2x
-  **B1** 2x
-  **C** 2x
-  **C1** 2x
-  **P** 4x
-  **1** 42x M6x15
- 5**

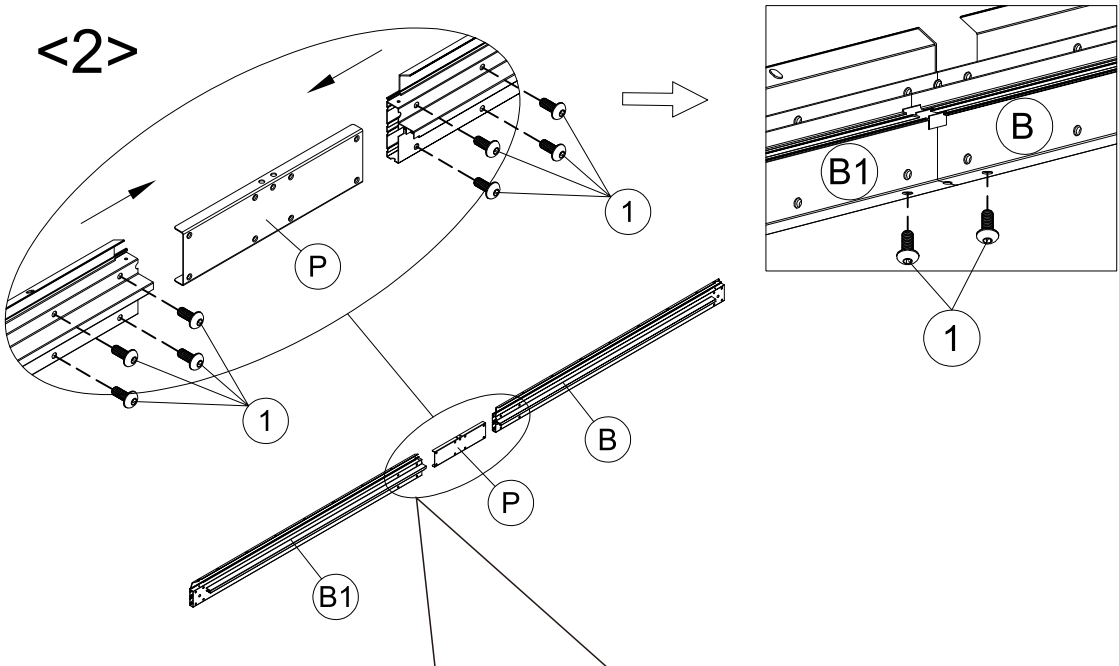

EN: This is divided into up and down directions, and the position of the hole refers to the enlarged view.  
 DE: Dies ist in Aufwärts- und Abwärtsrichtung unterteilt, und die Position des Lochs bezieht sich auf die vergrößerte Ansicht.  
 ES: Esto se divide en direcciones hacia arriba y hacia abajo, y la posición del orificio se refiere a la vista ampliada.  
 FR: Ceci est divisé en directions de haut en bas, et la position du trou se réfère à la vue agrandie.  
 IT: Questo è diviso in posizione verso il basso e verso l'alto, e la posizione del foro si riferisce alla visuale allargata.

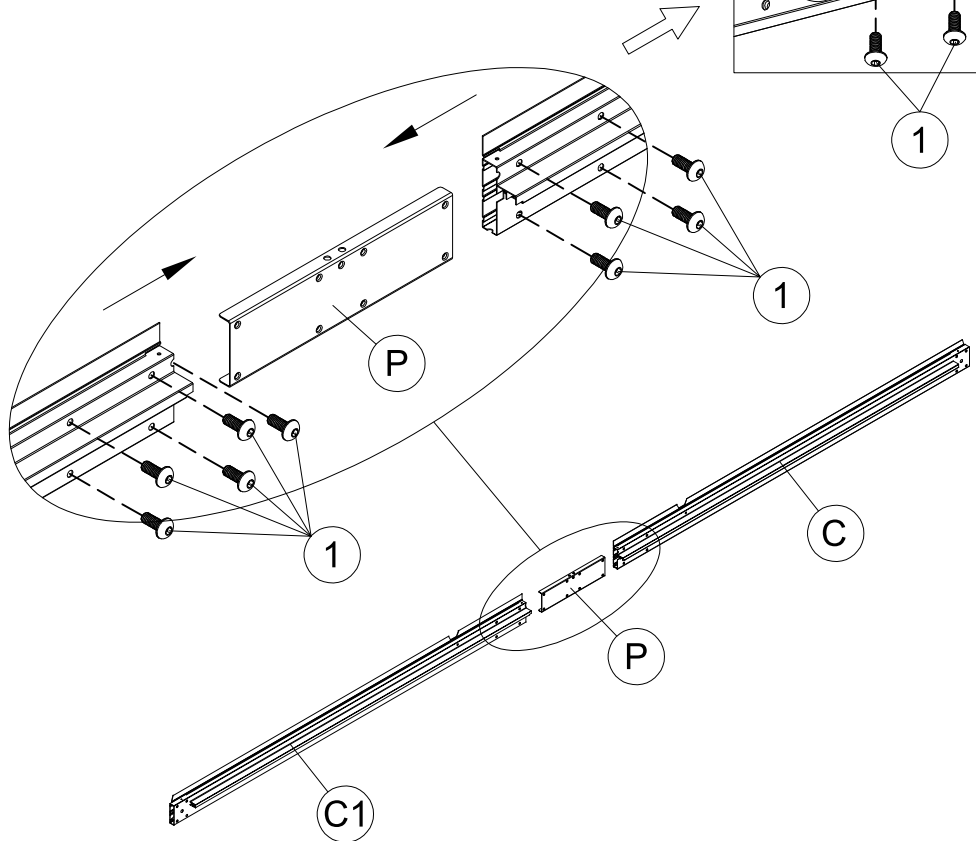
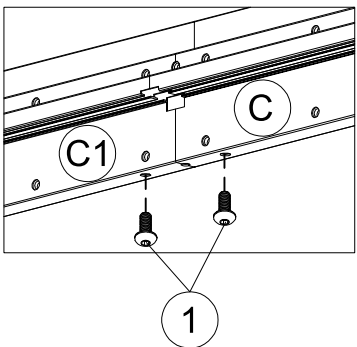

<3>

M6x10

2 32x

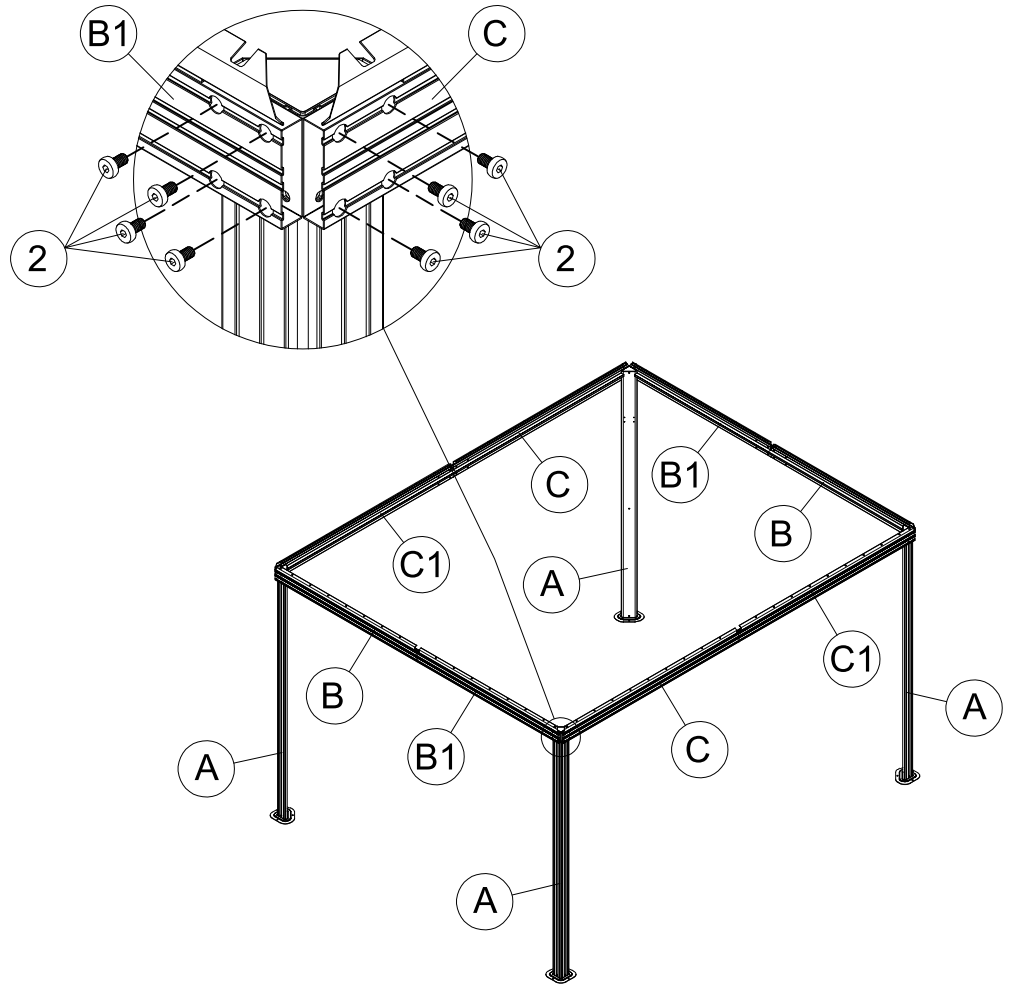

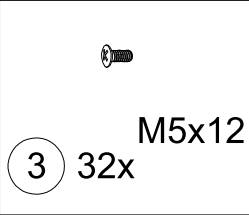
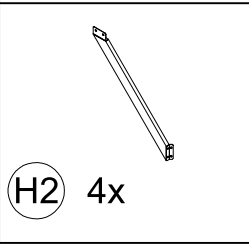
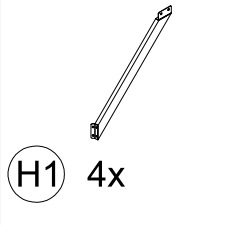

<4>

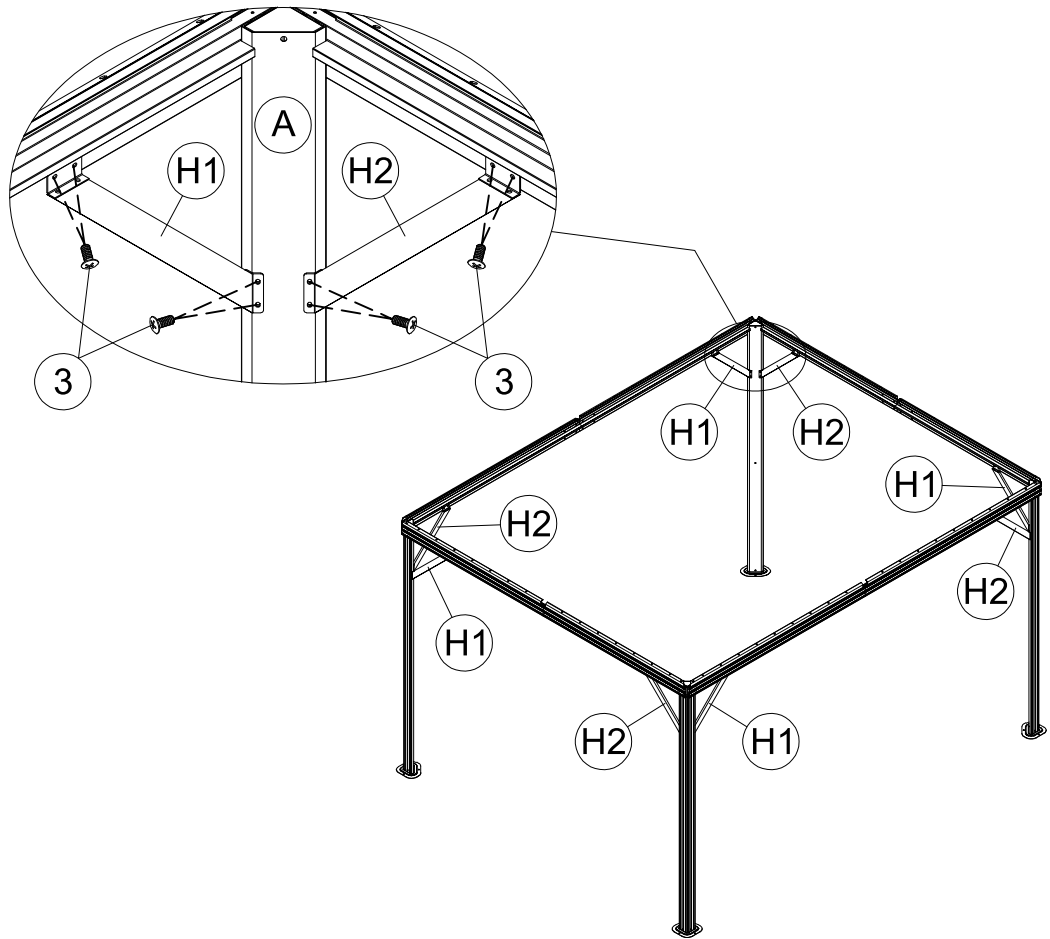

EN: Firstly, install the screws on the beam, but do not tighten them. After the uprights are tightened, then tighten the screws all. If the hole position is not aligned, move the uprights to adjust the position.

DE: Installieren Sie zunächst die Schrauben am Träger, ziehen Sie sie jedoch nicht fest. Nachdem die Pfosten festgezogen sind, ziehen Sie alle Schrauben fest. Wenn die Lochposition nicht ausgerichtet ist, bewegen Sie die Pfosten, um die Position anzupassen.

ES: Primero, instale los tornillos en la viga, pero no los apriete. Después de apretar los postes verticales, apriete todos los tornillos. Si la posición del agujero no está alineada, mueva los postes para ajustar.

FR: Tout d'abord, installez les vis sur le faisceau, mais ne pas les serrer. Une fois les montants serrés, serrez les vis. Si la position du trou n'est pas alignée, déplacez les montants pour ajuster la position.

IT: Innanzitutto, installare le viti sulla trave, ma non stringerle tutte. Dopo che i montanti sono stati fissati, stringere tutte le viti. Se la posizione del foro non è allineata, muovere ei montanti al fine di regolarne la posizione.





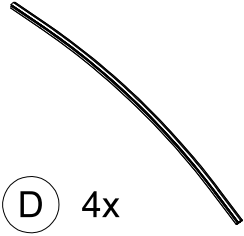

D 4x

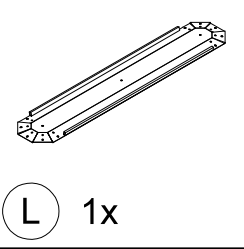

L 1x



1 12x M6x15

<6>

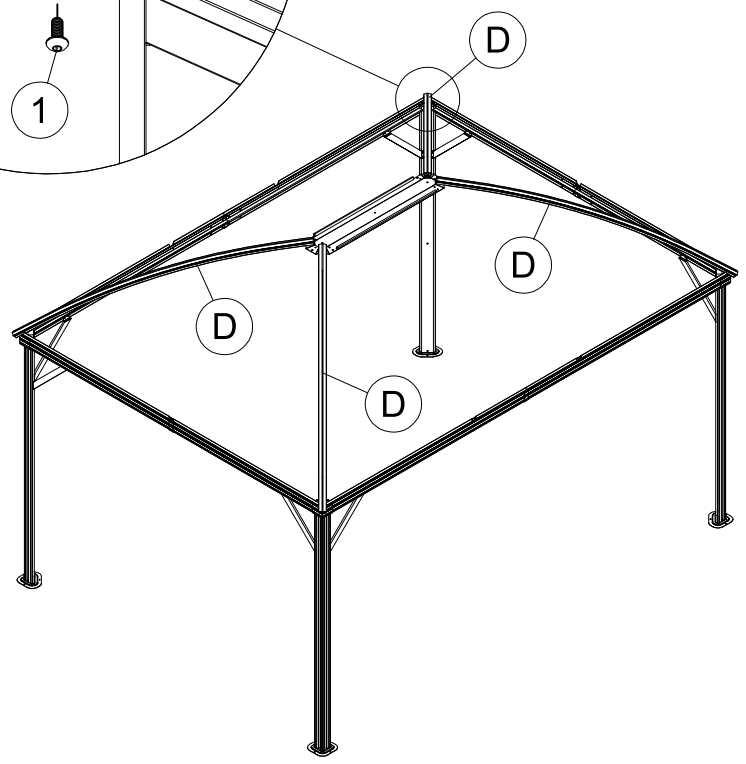
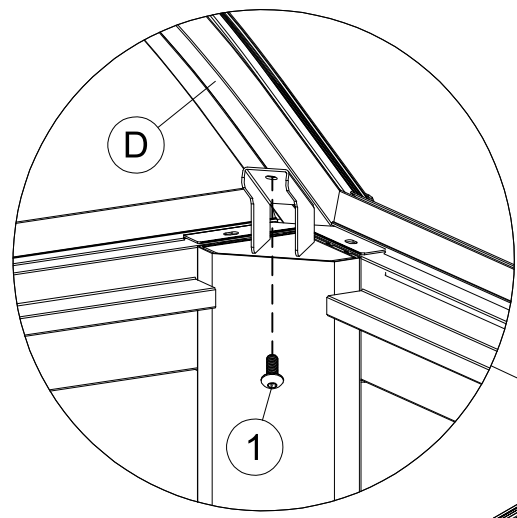
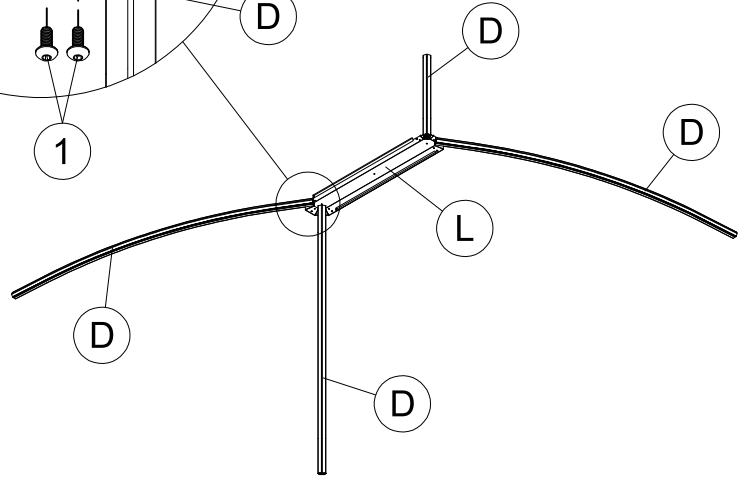
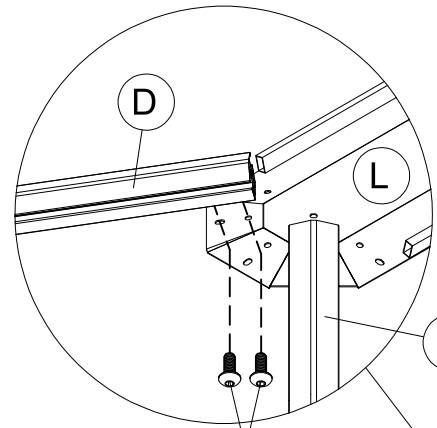

9



<7>

E 6x



1 18x M6x15

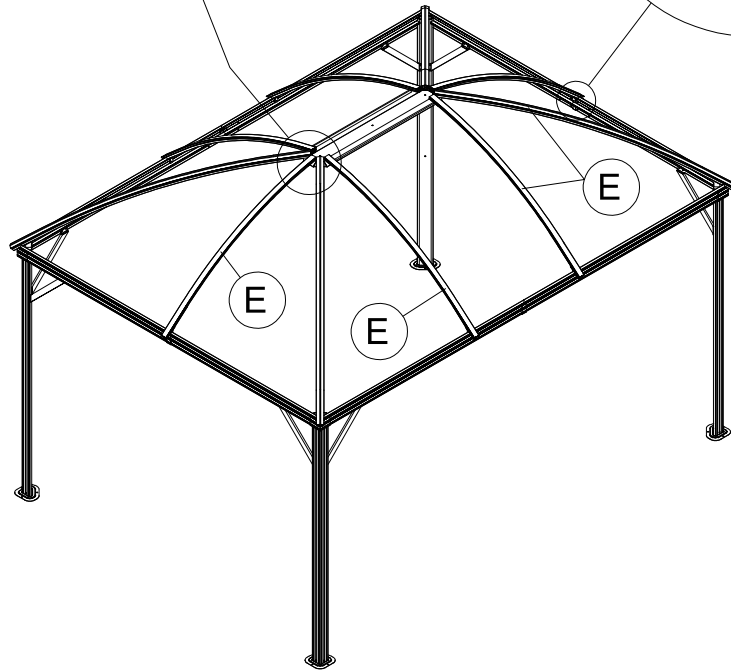
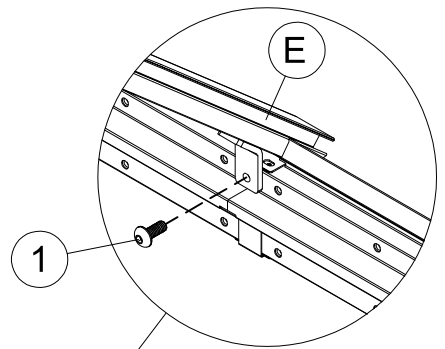
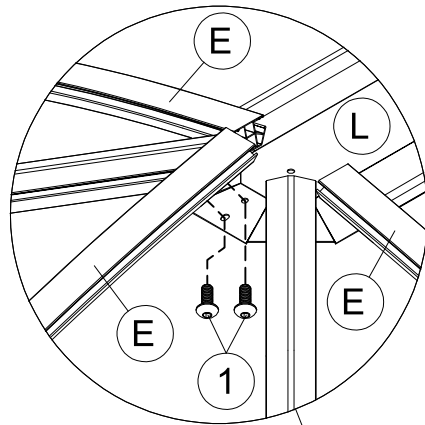

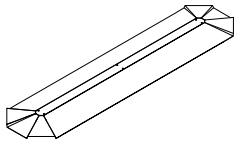

<8>

(M) 1x



(1) 1x M6x15



(5) 2x

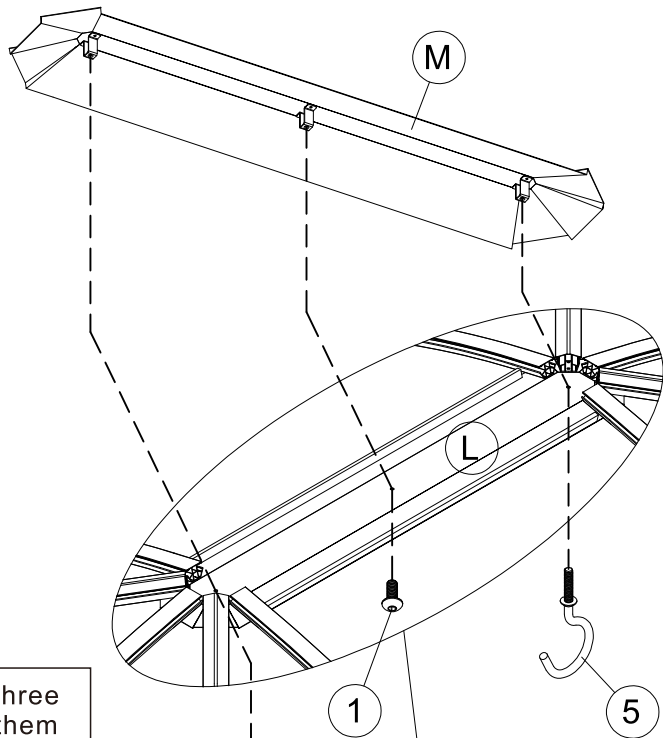

EN: Do not tighten these three screws now, and tighten them after 15 steps are completed.

DE: Ziehen Sie diese drei Schrauben jetzt nicht fest und ziehen Sie sie erst nach 15 Schritten fest.

ES: No apriete estos 3 tornillos ahora, después de completar el Paso 15, ya puede apretarlos.

FR: Ne serrez pas ces trois vis maintenant, et serrez-les après 15 étapes sont terminées.

IT: Non stringere queste viti ora, ma stringerle dopo il completamento dei 15 passaggi.

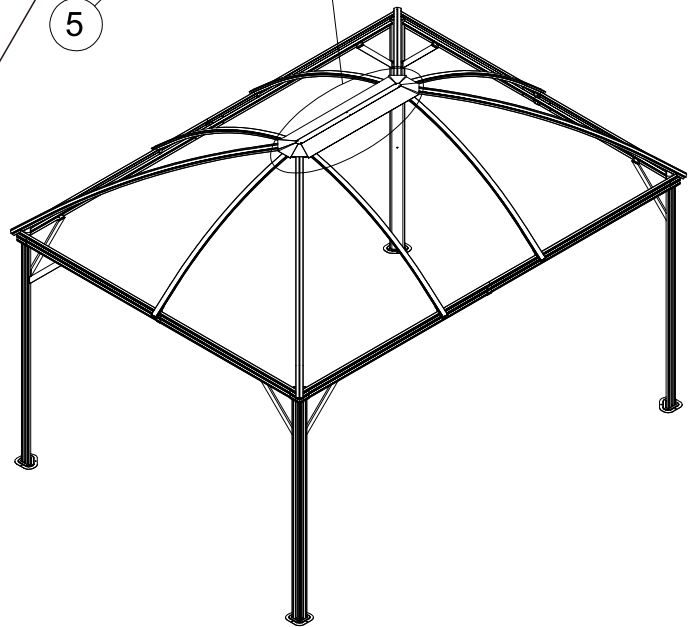

<9>



F 2x

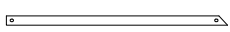

F1 8x



W 4x

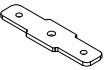

W1 6x



1 M6x15  
30x

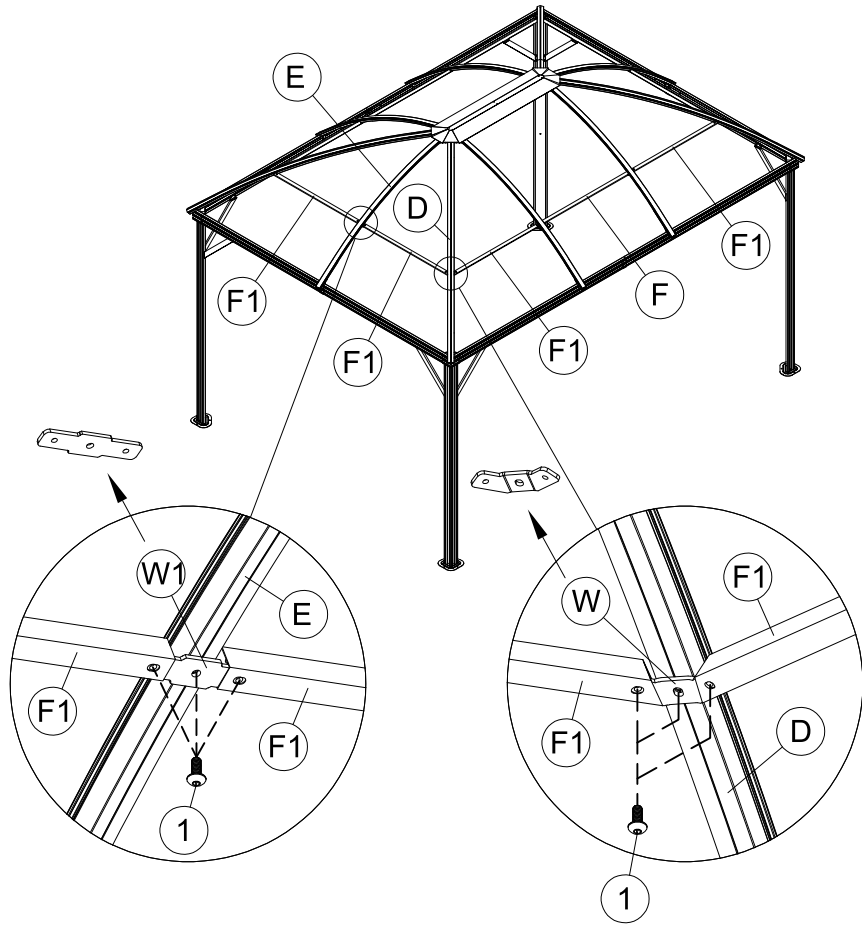

EN: Install in the same direction, do not tighten screws fully until all parts are connected.

DE: Installieren Sie in die gleiche Richtung und ziehen Sie die Schrauben nicht fest an, bis alle Teile angeschlossen sind.

ES: Instale en la misma dirección, no apriete los tornillos de manera completa hasta que todas las partes estén conectadas.

FR: Installez dans le même sens, ne serrez pas les vis à fond tant que toutes les pièces ne sont pas connectées.

IT: Installare nella stessa direzione, non stringere le viti completamente finché tutte le parti non sono state connesse.

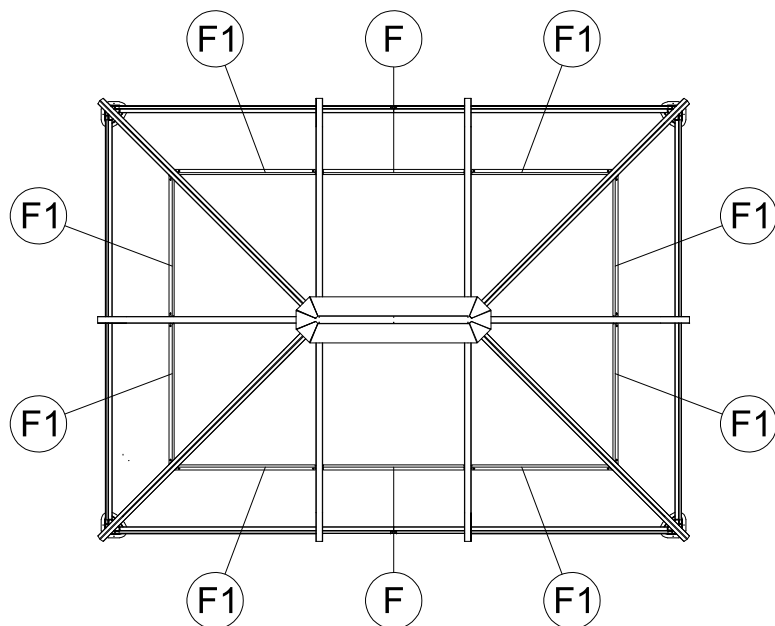

12

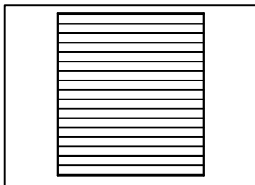

Q 2x

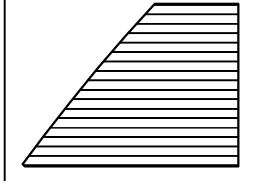

Q1 4x

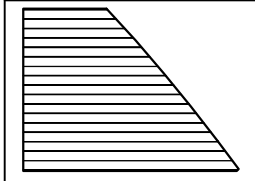

Q2 4x

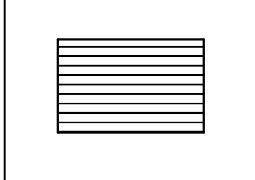

R 2x

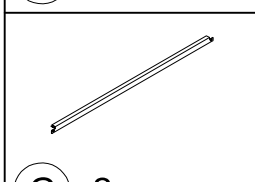

G 2x

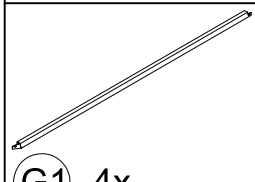

G1 4x

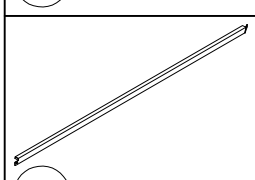

G2 4x

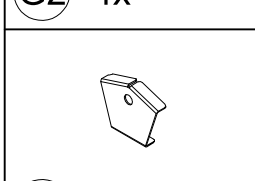

N 4x

13

<10>

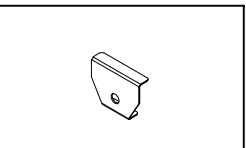
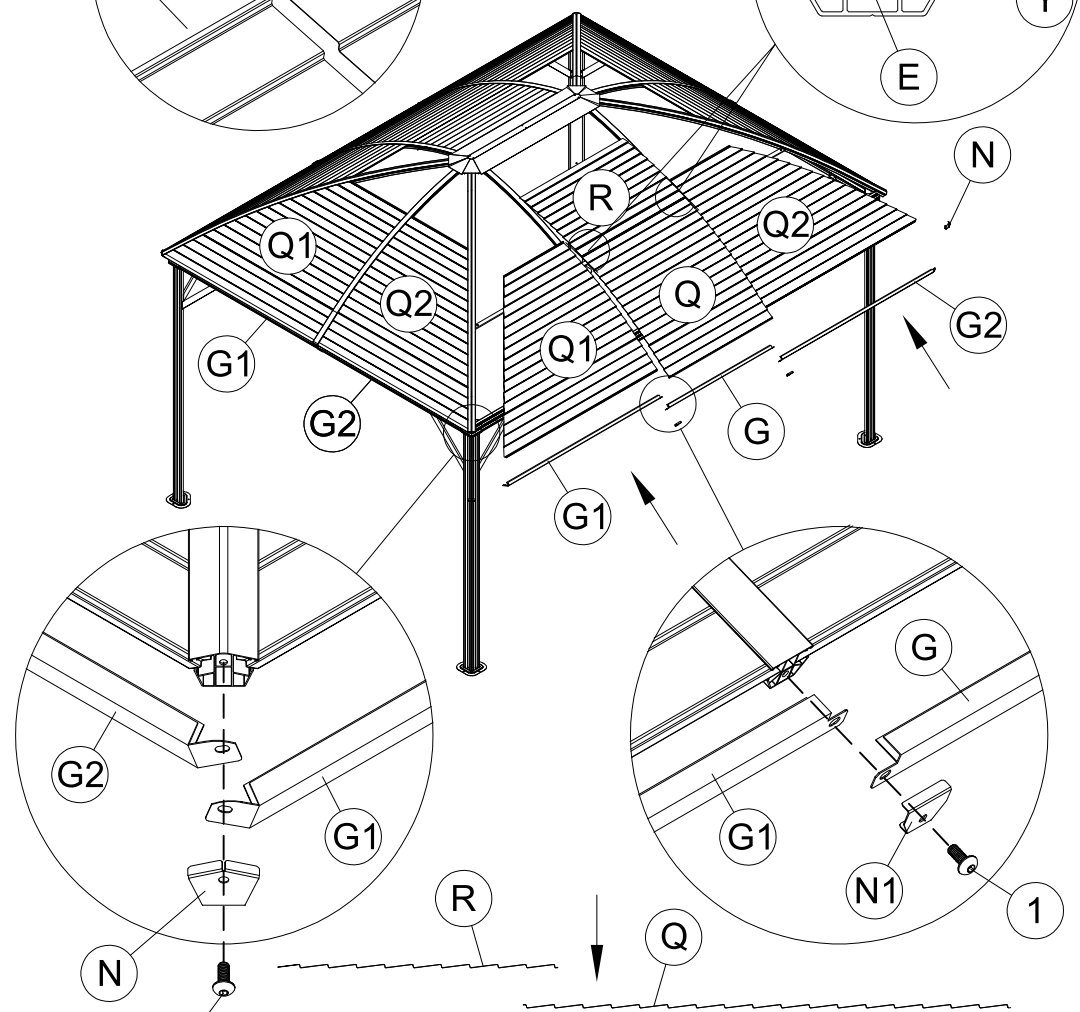
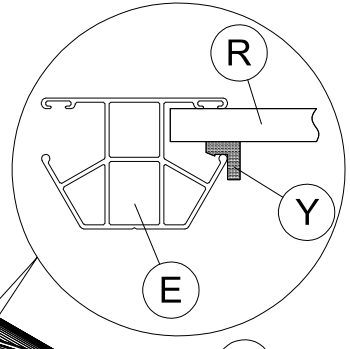
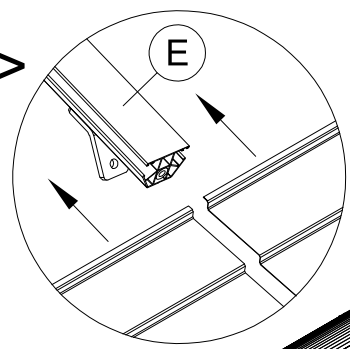

N1 6x

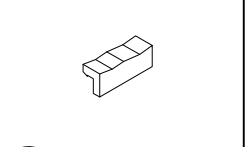

Y 4x

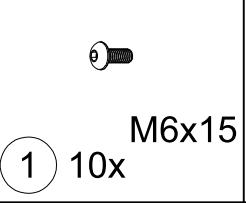

1 10x M6x15

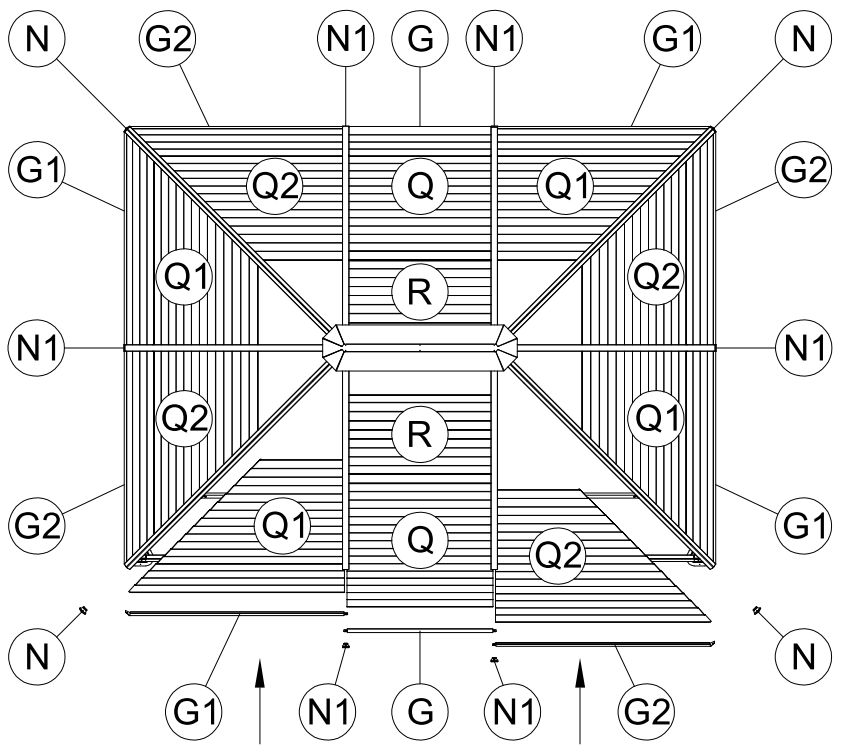

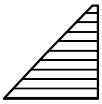

R1 4x

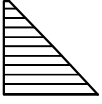

R2 4x

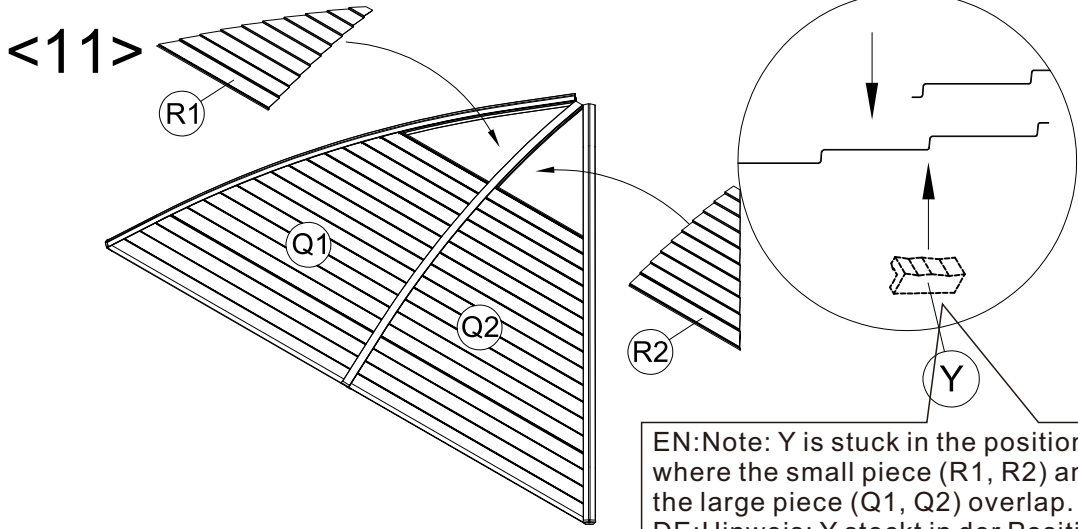

EN:Note: Y is stuck in the position where the small piece (R1, R2) and the large piece (Q1, Q2) overlap.  
 DE:Hinweis: Y steckt in der Position fest, wo sich das kleine Stück (R1, R2) und das große Stück (Q1, Q2) überlappen.  
 ES:Nota: Y está atascado en el lugar donde la pieza pequeña (R1, R2) y la pieza grande (Q1, Q2) se traslapan.  
 FR:Note : Y est coincé dans la position où le petit morceau (R1, R2) et le grand morceau (Q1, Q2) se chevauchent.  
 IT:Nota: Y va inserito nella posizione dove le parti piccole (R1, R2) e quelle grandi (Q1, Q2) si sovrappongono.

EN:According to the installation order of (Q1,R1)→(Q2,R2)→(Q,R) is the best. There is a small hole on the edge of each sheet of iron. This is only a craft hole, not a defect. The small hole is invisible after installation.

DE:Die Installationsreihenfolge nach (Q1, R1) → (Q2, R2) → (Q, R) ist die beste. Am Rand jedes Eisenblechs gibt es ein kleines Loch. Dies ist nur ein Bastelloch, kein Defekt. Das kleine Loch ist nach der Installation unsichtbar.

ES:Es mejor instalar según el orden de (Q1, R1) → (Q2, R2) → (Q, R). Hay un pequeño agujero en el borde de cada hoja de hierro, que es solo un agujero de artesanía, no es un defecto. Después de la instalación, el pequeño orificio no es visible.

FR:Selon l'ordre d'installation de (Q1, R1) → (Q2, R2) → (Q, R) est le meilleur. Il y a un petit trou sur le bord de chaque feuille de fer. Ce n'est qu'un trou d'artisanat, pas un défaut. Le petit trou est invisible après l'installation.

IT:L'ordine di installazione (Q1,R1)→(Q2,R2)→(Q,R) e' il migliore. C'e' un piccolo foro all'estremita' di ogni lamina di metallo. Questo e' un foro di lavorazione e non un difetto. Il foro e' invisibile dopo l'installazione.

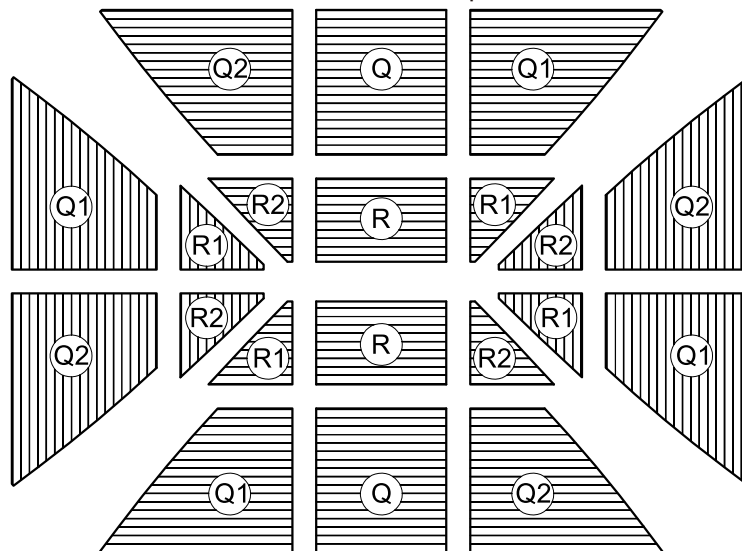



<12>

Y 16x

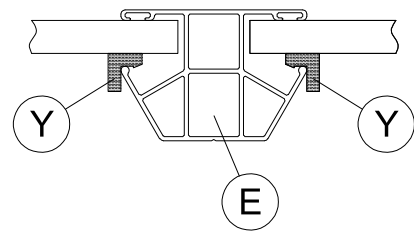
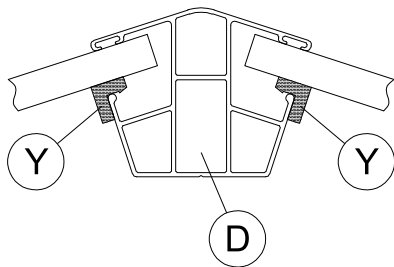
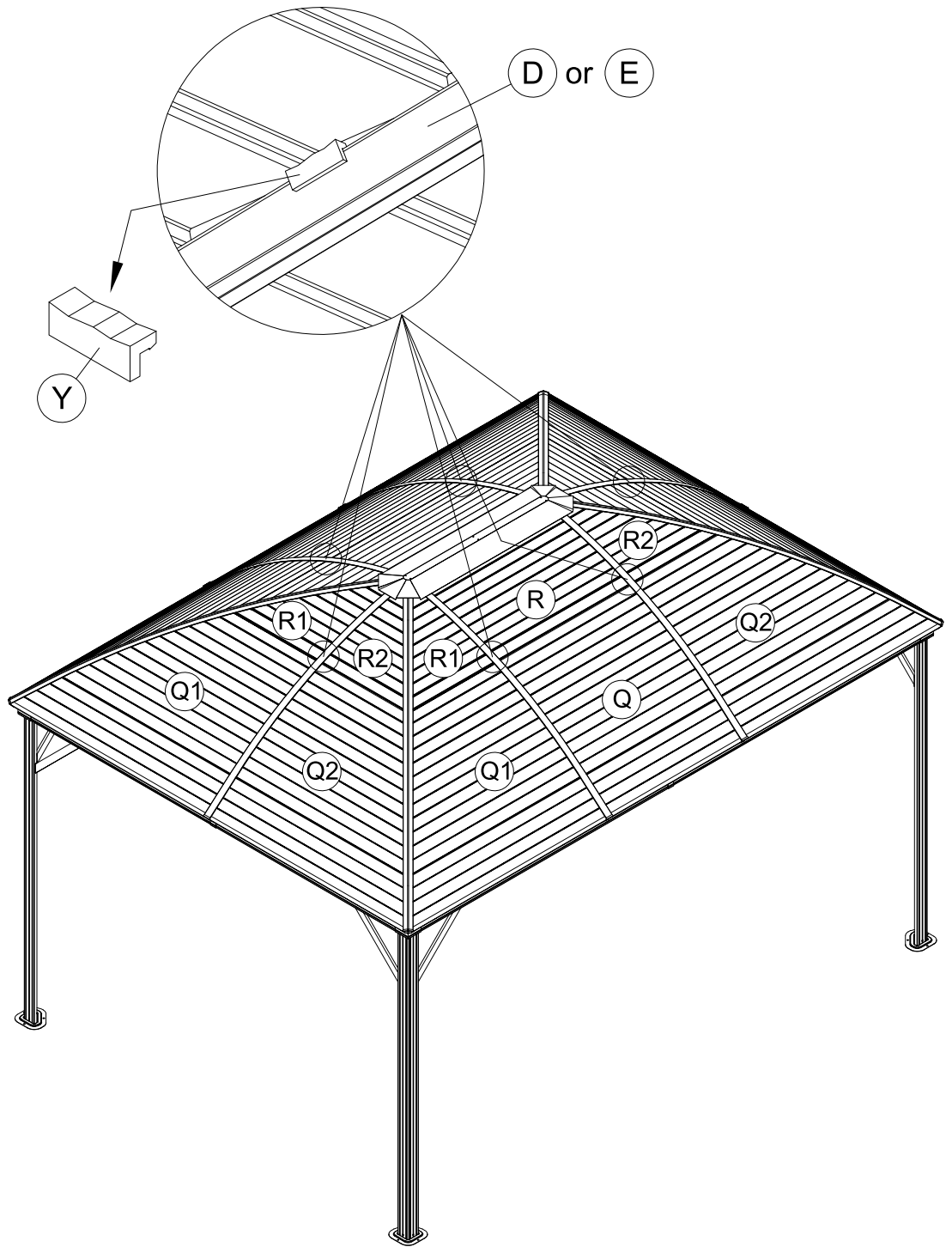

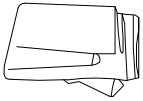

<13>

T 4x

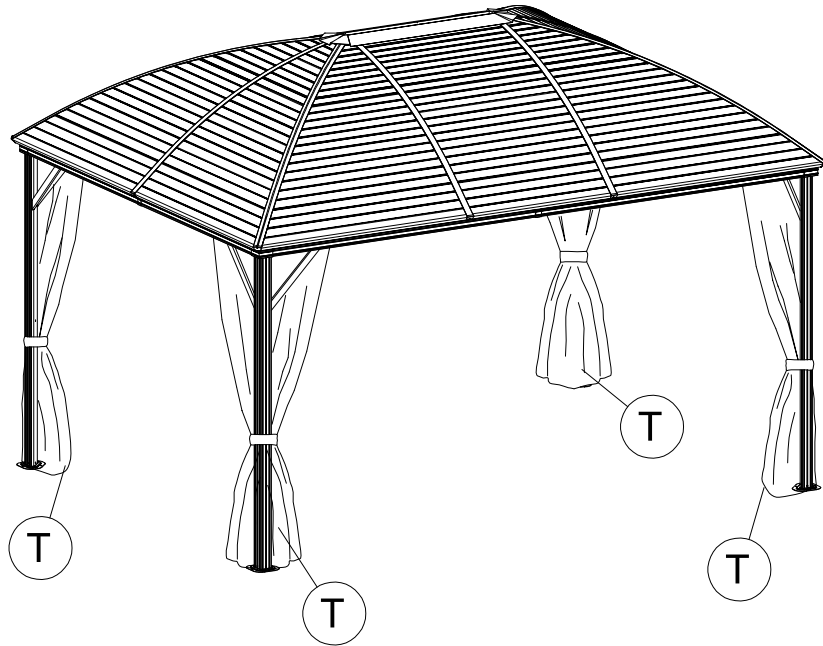
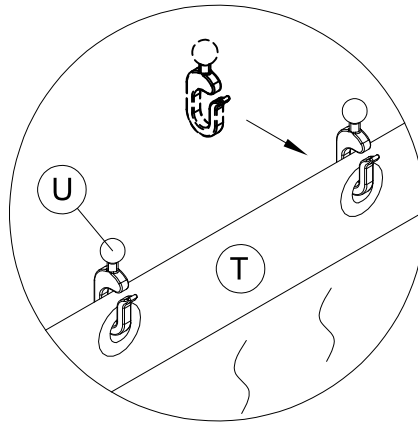
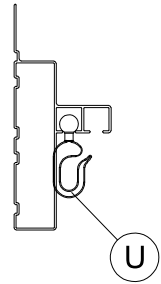

EN:1.S and T are divided into left and right directions, identification method: take apart the four zippers, and install S/T in a single piece.

The iron hook on S passes through the hole on T and hooks on the small hole of the upright.

2. There is no separate Bandage on T, the Bandage has been sewn on S.

DE:1.S und T sind in linke und rechte Richtung unterteilt. Identifikationsmethode: Nehmen Sie die vier Reißverschlüsse auseinander und installieren Sie S / T in einem Stück.

2. Der Eisenhaken an S geht durch das Loch an T und hakt an dem kleinen Loch des Pfostens.

2. Es gibt keinen separaten Verband auf T, der Verband wurde auf S genäht.

ES:1.S y T se dividen en direcciones izquierda y derecha, el método de identificación es siguiente: Desmontar las cuatro cremalleras e instalar S / T como una sola pieza.

2. El gancho de hierro en S pasa a través del orificio en T y se engancha en el pequeño orificio del poste.

No hay un vendaje separado en T, el vendaje se ha cosido en S.

FR:1.S et T sont divisés en directions gauche et droite, méthode d'identification : démontez les quatre fermetures éclair, et installez S / T en une seule pièce. Le crochet en fer sur S passe à travers le trou sur T et crochets sur le petit trou du montant.

2. Il n'y a pas de bandage séparé sur T, le bandage a été cousu sur S.

IT:1.S e T sono divisa tra direzione sinistra e destra, identificabili in questo modo: slacciare le quattro cerniere e installare S/T in un solo pezzo.

Il gancio in metallo su S passa attraverso il foro di T e si aggancia al piccolo foro del montante.

2. Non ci sono cinghie separate su T, la cinghia e' stata cucita su S.



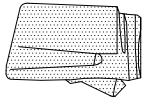

<14>

S 4x

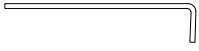

Z1 12x





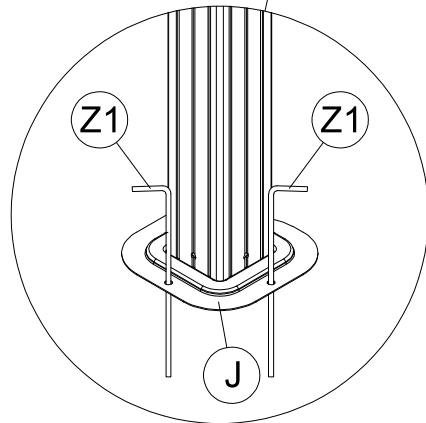
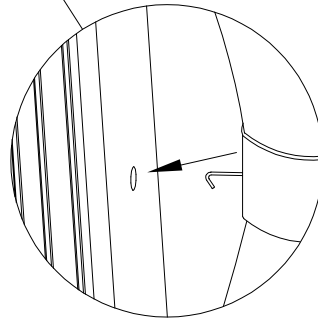
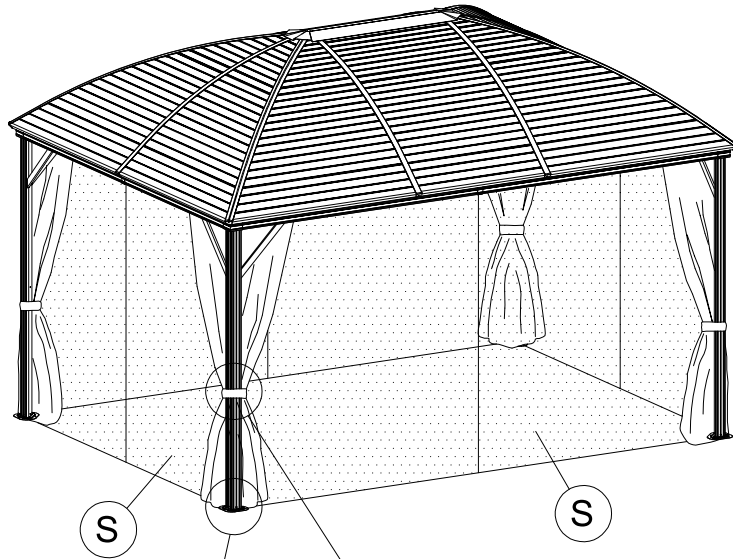
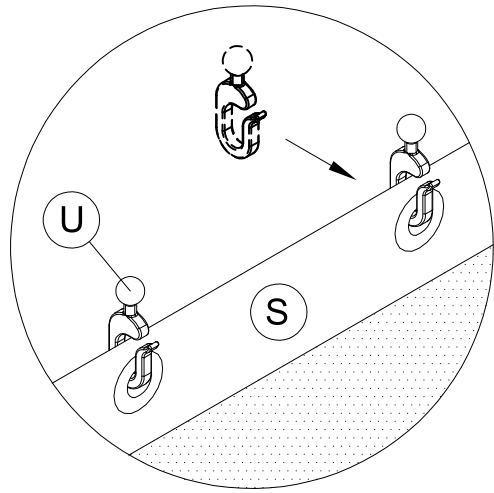
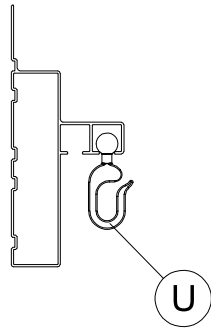



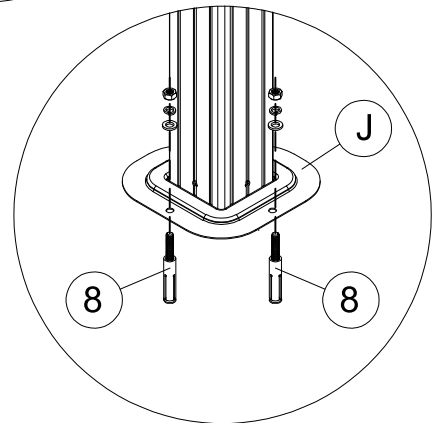











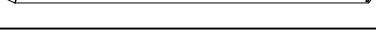
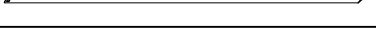
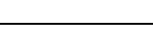
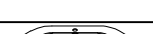

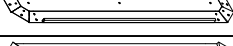
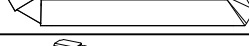

8 12x

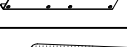
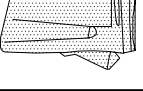
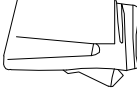

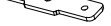

or

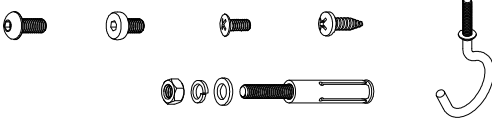
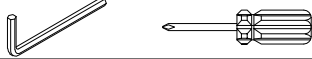

Carton-1/2	No	Reference Picture	Part	Qty
	1		A	4
	2		B	2
	3		B1	2
	4		C	2
	5		C1	2
	6		D	4
	7		E	6
	8		F	2
	9		F1	8
	10		G	2
	11		G1	4
	12		G2	4
	13		H1	4
	14		H2	4
	15		J	4
	16		K	4
	17		K1	4
	18		L	1
	19		M	1
	20		N	4
	21		N1	6
	22		P	4
	23		S	4
	24		T	4
	25		U	112
	26		V	4
18	27		W1	4
	28		W2	6

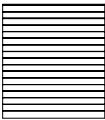
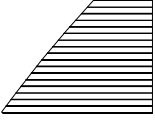
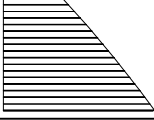
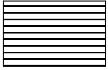
Carton-1/2	No	Reference Picture	Part	Qty
	29		Y	20
	30		Z1	12
	31		1,2,3,4, 5,8	231
	32			2

Carton-2/2	No	Reference Picture	Part	Qty
	1		Q	2
	2		Q1	4
	3		Q2	4
	4		R	2
	5		R1	4
	6		R2	4

US



001-877-644-9366  
customerservice@aosom.com

CA



001-855-537-6088  
customerservice@aosom.ca

UK



0044-800-240-4004  
enquiries@mhstar.co.uk

DE



0049-(0)40-88307530  
service@aosom.de

FR



0033-1-84166106  
contact@aosom.fr

ES



0034-931294512  
atencioncliente@aosom.es

IT



0039-0249471447  
clienti@aosom.it