

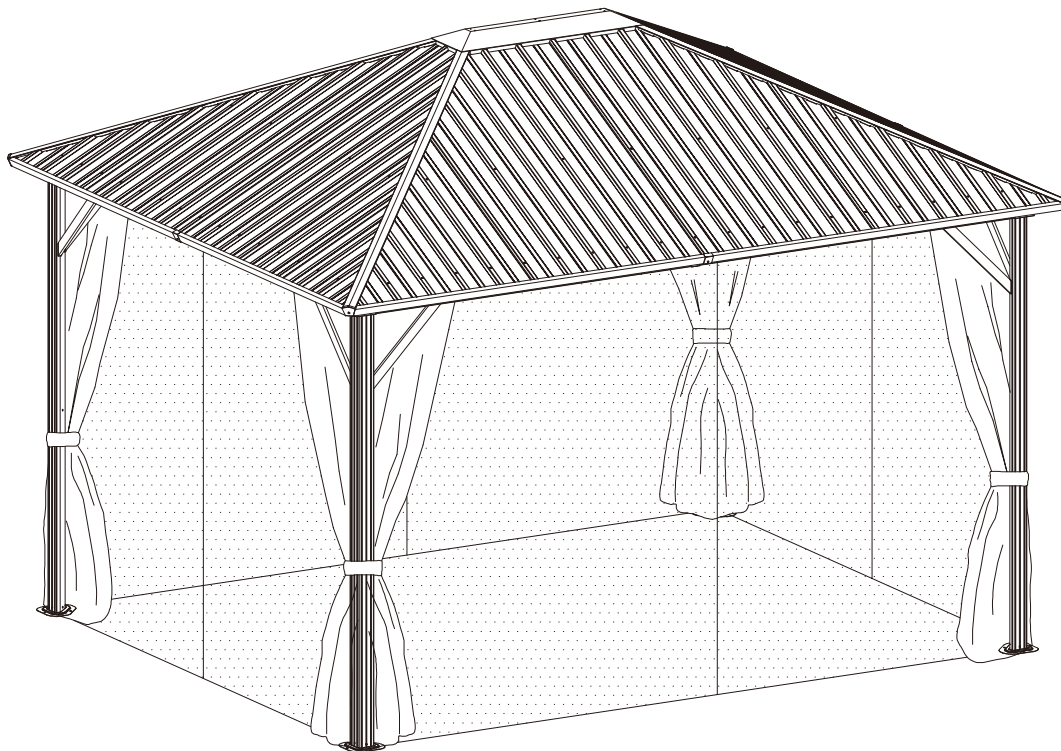

INbed005V01_GL

84C-095



REQUIRED TOOLS

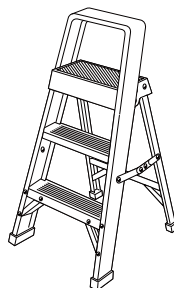
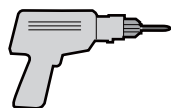

Assembly video please scan the QR code .

READ AND SAVE THIS INSTRUCTION FOR FUTURE USE

ASSEMBLY INSTRUCTION



A 4x



B 2x



B1 2x



C 2x



C1 2x



D 4x



E 4x

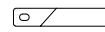

F1 2x

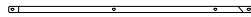

F2 2x

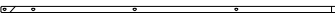

F3 2x

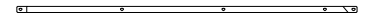

F4 2x



G1 2x



G2 2x



G3 2x



G4 2x

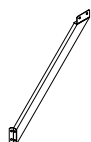

H1 4x

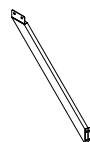



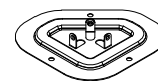



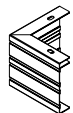



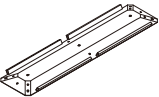
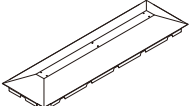

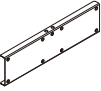
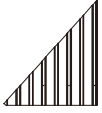
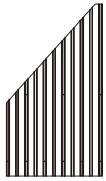
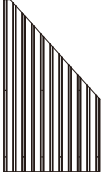
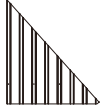
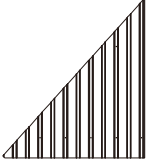
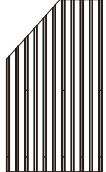
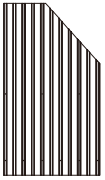
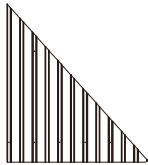
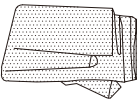





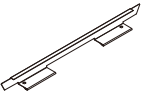

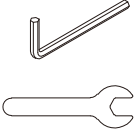
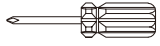
H2 4x



J 4x



K 4x

			
(K1) 4x	(L) 1x	(M) 1x	(N) 4x
			
(N1) 4x	(P) 4x	(Q1) 2x	(Q2) 2x
			
(Q3) 2x	(Q4) 2x	(R1) 2x	(R2) 2x
			
(R3) 2x	(R3) 2x	(S) 4x	(T) 4x
			
(U) 104x	(V) 4x	(W) 12x	(Y) 92x
			
(Z) 56x	(Z1) 8x	1	1x
	 8x + 1   64x + 3		
M6x15 (1) 77x + 3	M6x23 (2)	M5x12 (3) 48x + 2	ST4.8x12 (4) 24x + 2
			
(5) 2x	M6x42 (6) 20x + 1	M6x10 (7) 32x + 1	(8) 12x

<1>

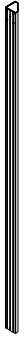

A 4x

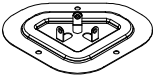





J 4x

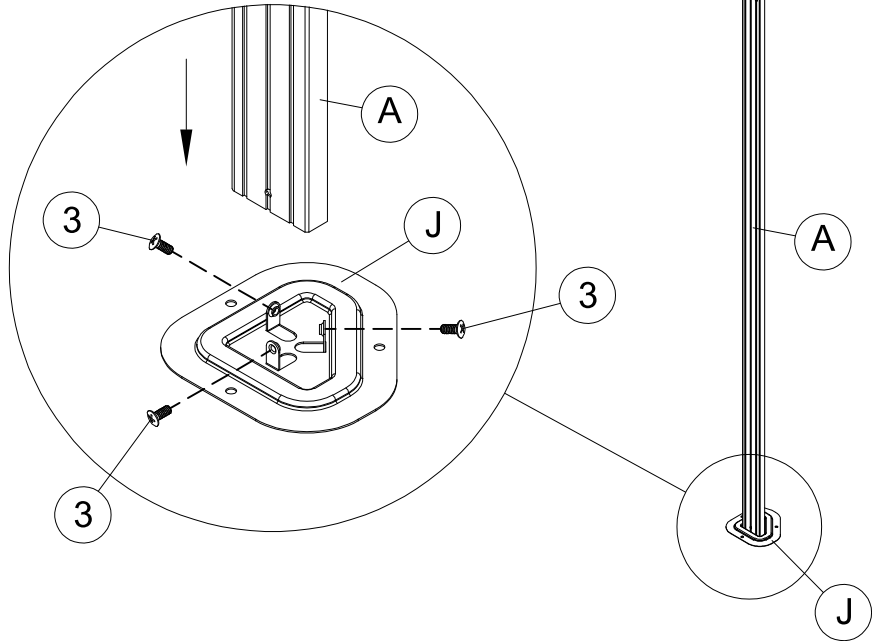

3 12x M5x12

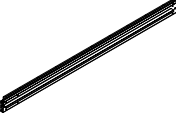
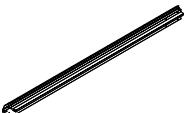
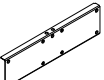

4

-  **(B)** 2x
-  **(B1)** 2x
-  **(C)** 2x
-  **(C1)** 2x
-  **(P)** 4x
-  **(1)** 40x M6x15
- 5**

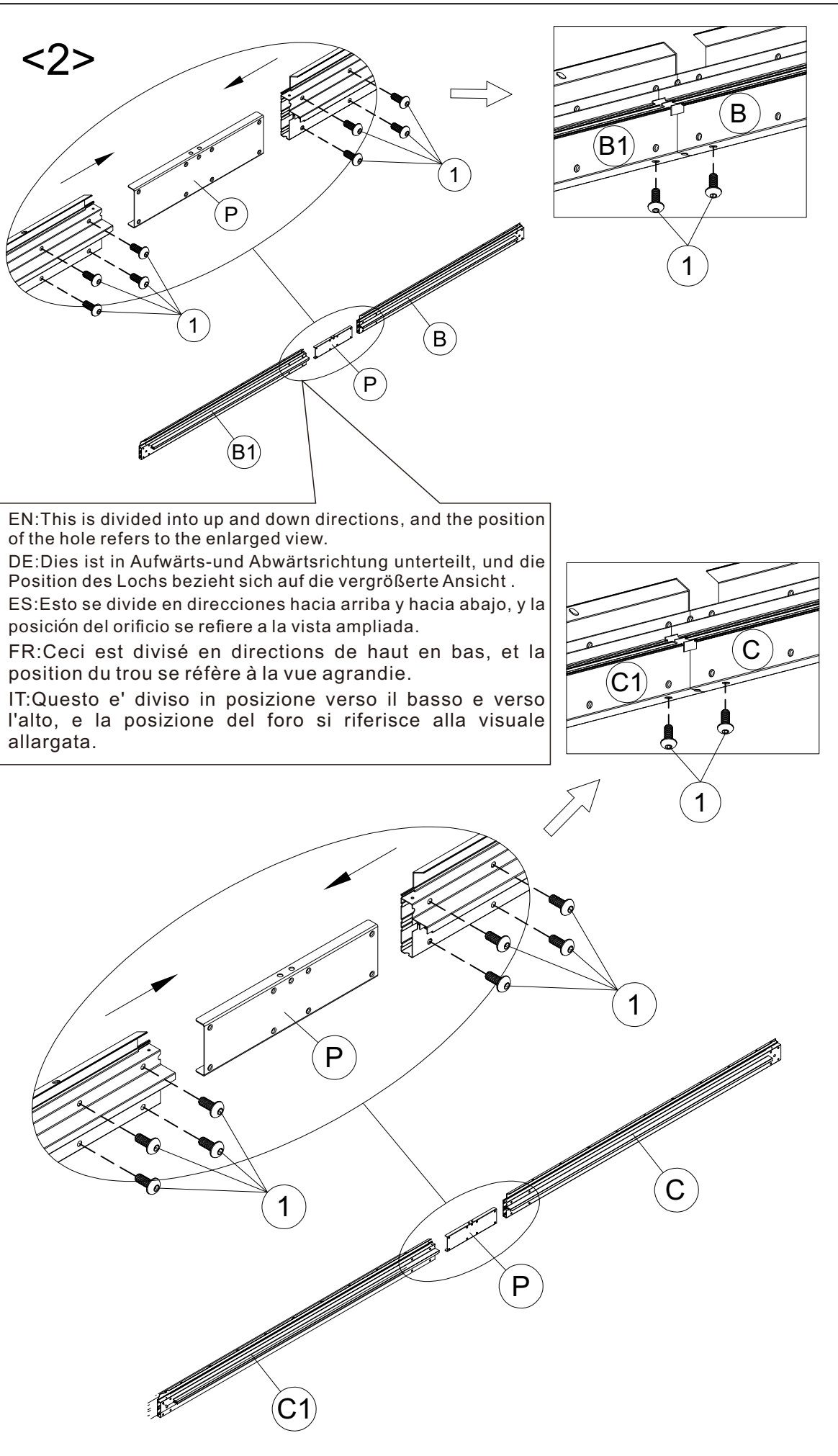

<3>



2 32x

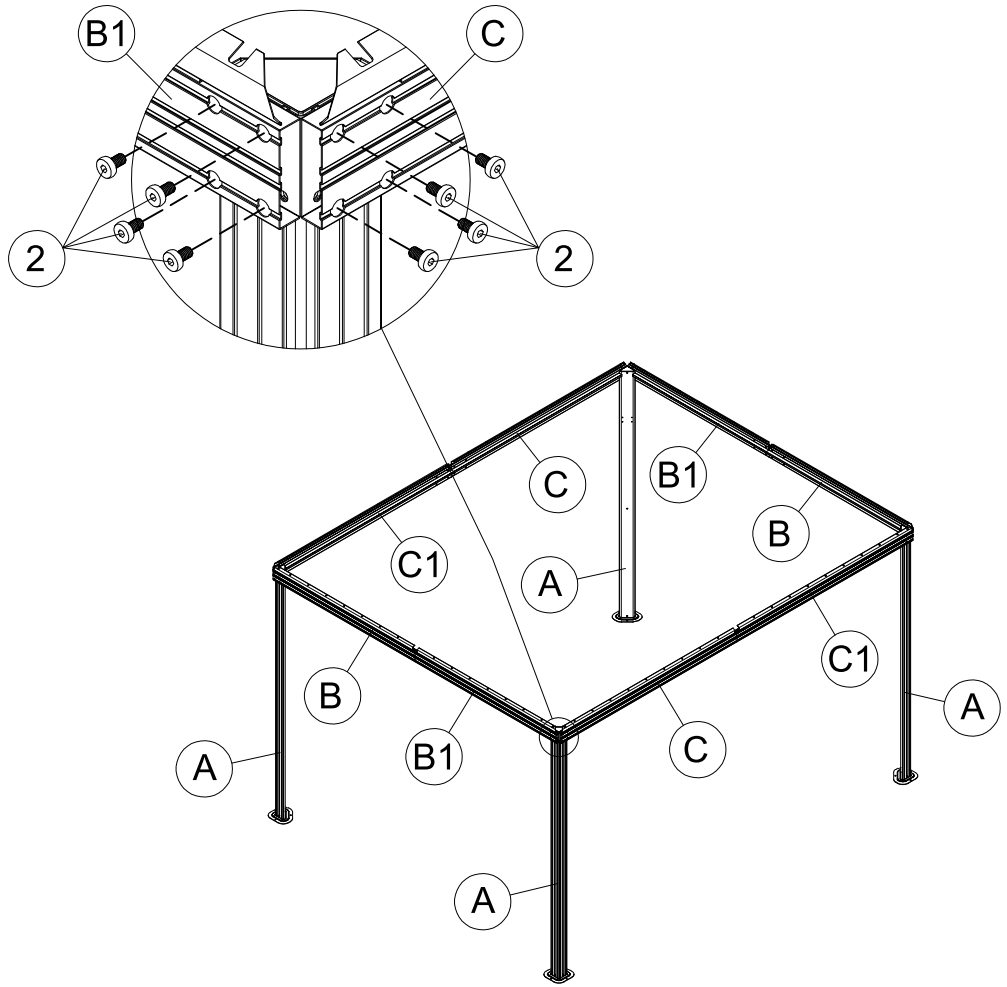

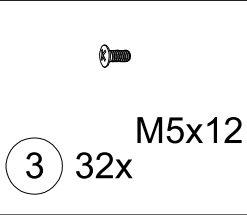
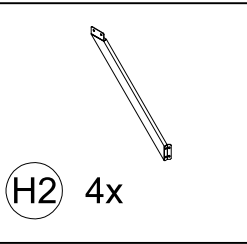
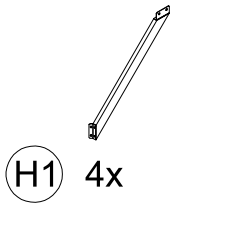

<4>

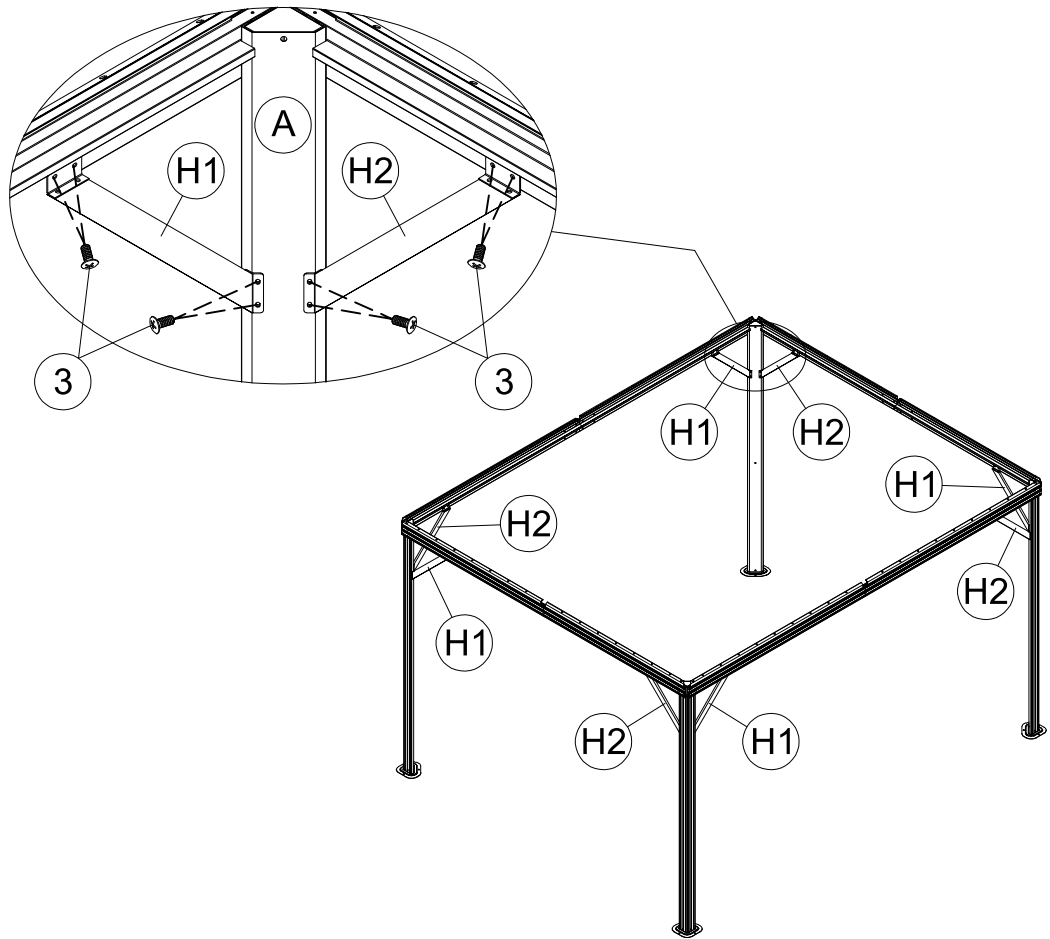

EN: Firstly, install the screws on the beam, but do not tighten them. After the uprights are tightened, then tighten the screws all. If the hole position is not aligned, move the uprights to adjust the position.

DE: Installieren Sie zunächst die Schrauben am Träger, ziehen Sie sie jedoch nicht fest. Nachdem die Pfosten festgezogen sind, ziehen Sie alle Schrauben fest. Wenn die Lochposition nicht ausgerichtet ist, bewegen Sie die Pfosten, um die Position anzupassen.

ES: Primero, instale los tornillos en la viga, pero no los apriete. Después de apretar los postes verticales, apriete todos los tornillos. Si la posición del agujero no está alineada, mueva los postes para ajustar.

FR: Tout d'abord, installez les vis sur le faisceau, mais ne pas les serrer. Une fois les montants serrés, serrez les vis. Si la position du trou n'est pas alignée, déplacez les montants pour ajuster la position.

IT: Innanzitutto, installare le viti sulla trave, ma non stringerle tutte. Dopo che i montanti sono stati fissati, stringere tutte le viti. Se la posizione del foro non è allineata, muover ei montanti al fine di regolarne la posizione.



(K) 4x



(K1) 4x



(U) 104x



(V) 4x



(3) 4x M5x12



(4) 24x ST4.8x12

<5>

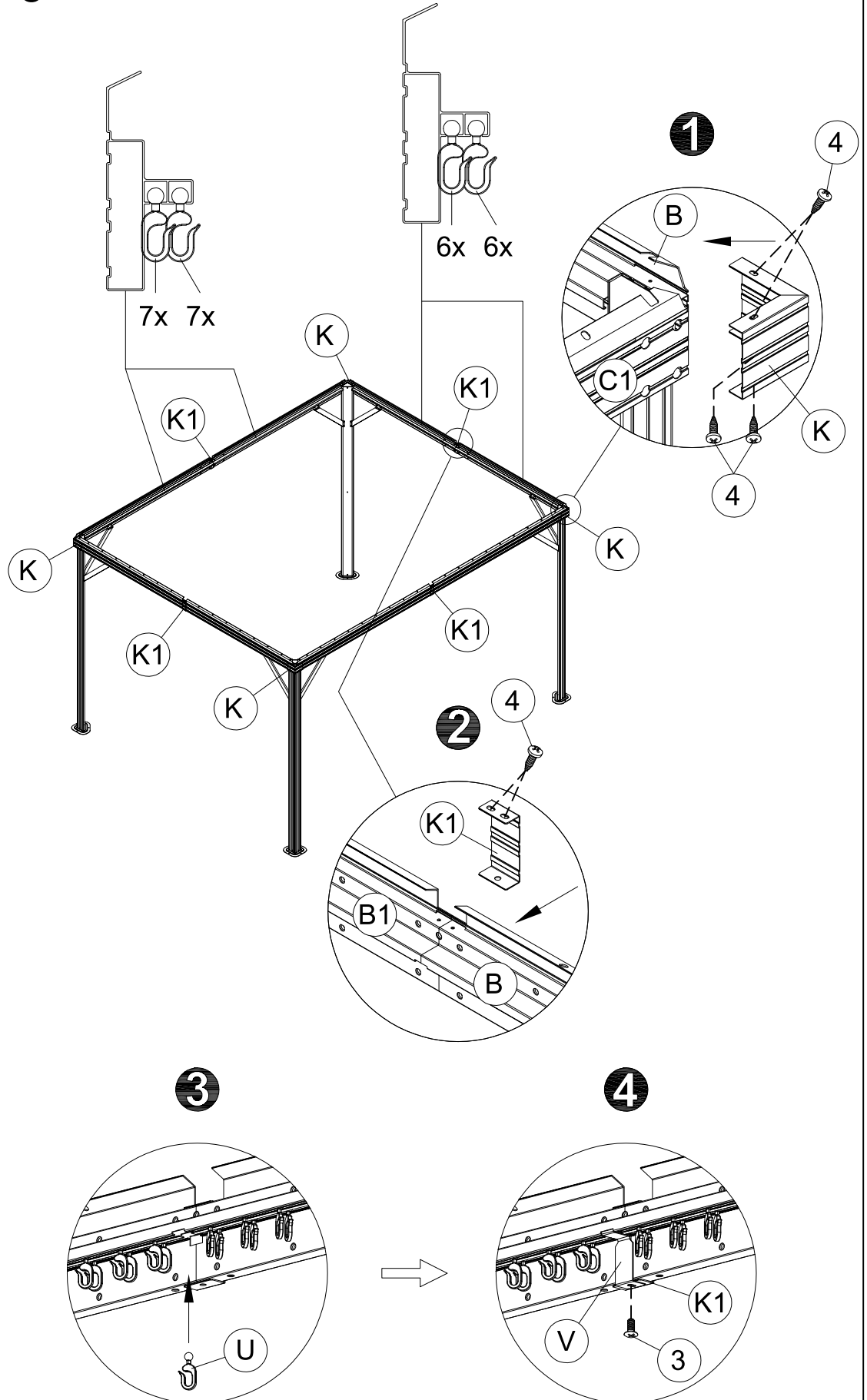

8

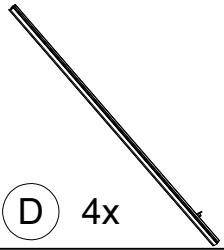

D 4x

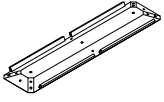

L 1x



1 M6x15
12x

<6>

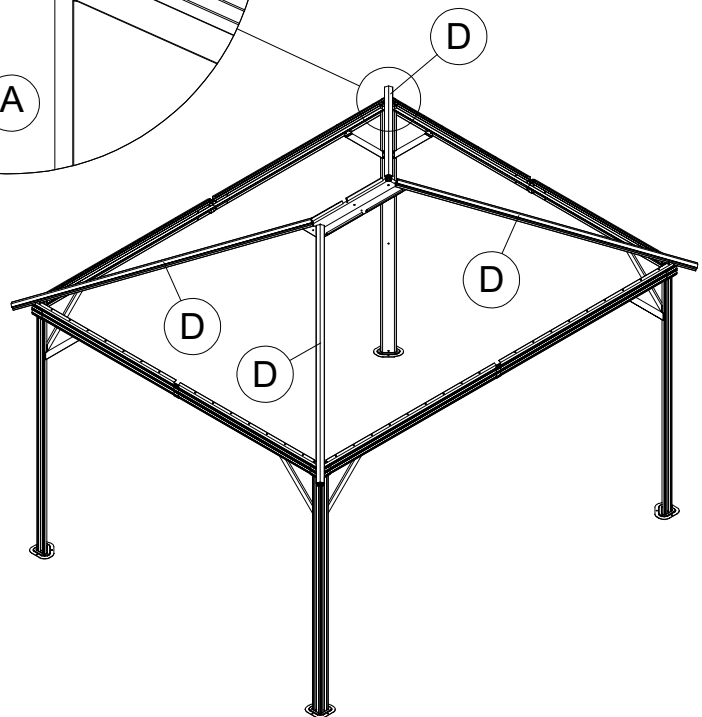
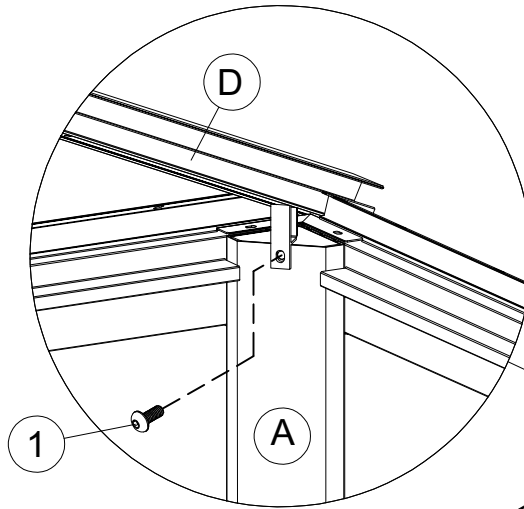
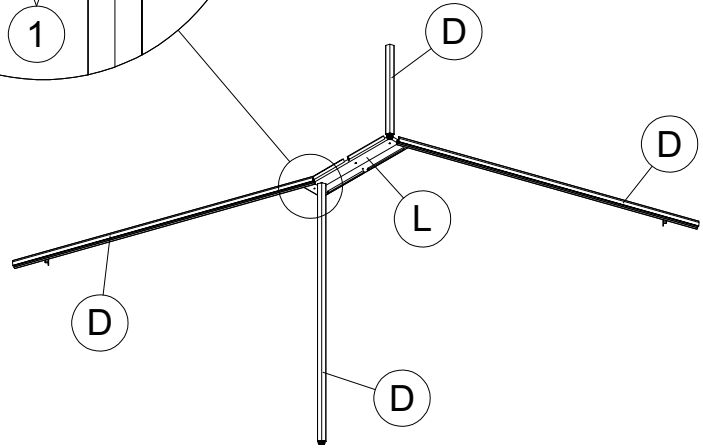
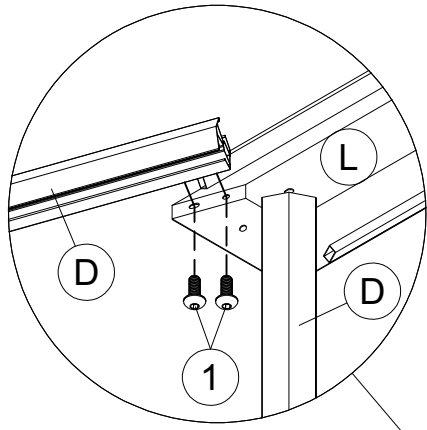

9

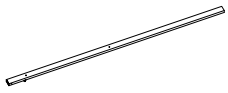

<7>

E 4x



1 8x M6x15

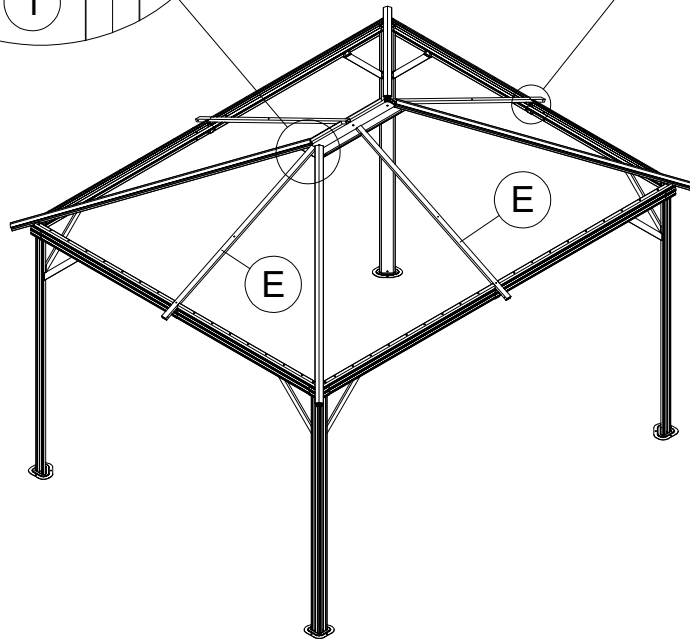
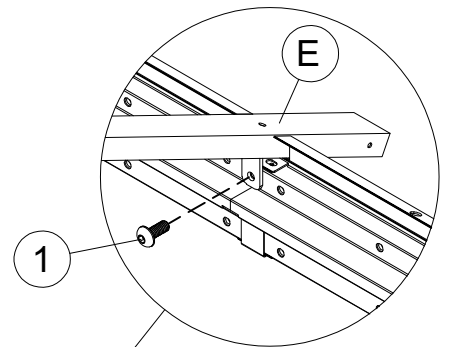
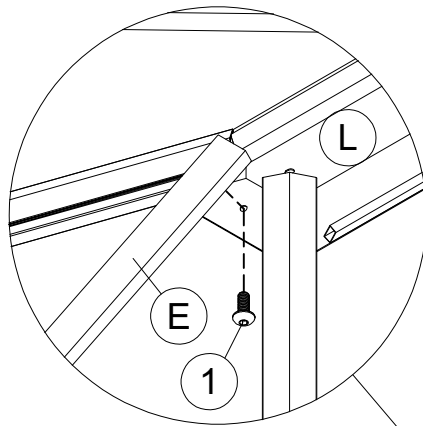

10

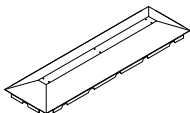

<8>

(M) 1x



(1) 1x M6x15



(5) 2x

EN: Do not tighten these three screws now, and tighten them after 15 steps are completed.

DE: Ziehen Sie diese drei Schrauben jetzt nicht fest und ziehen Sie sie erst nach 15 Schritten fest.

ES: No apriete estos 3 tornillos ahora, después de completar el Paso 15, ya puede apretarlos.

FR: Ne serrez pas ces trois vis maintenant, et serrez-les après 15 étapes sont terminées.

IT: Non stringere queste viti ora, ma stringerle dopo il completamento dei 15 passaggi.

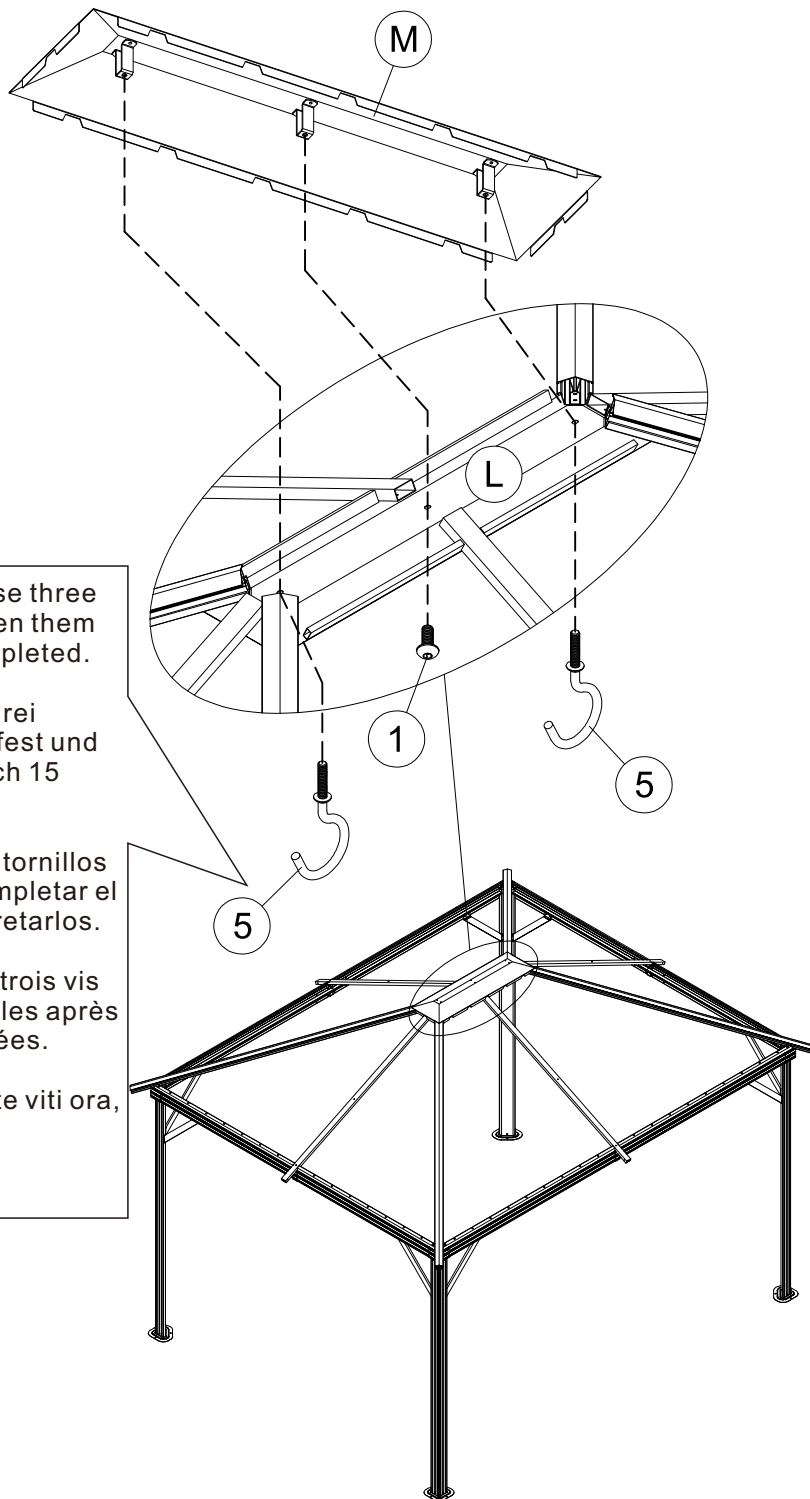

<9>

F1 2x

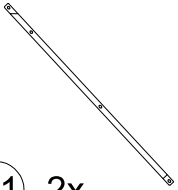

F2 2x

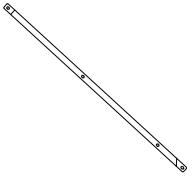

F3 2x

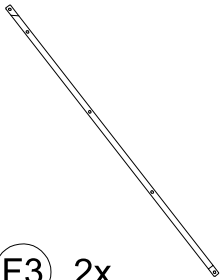

F4 2x

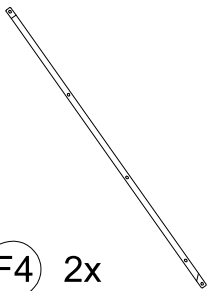

1 8x

M6x15

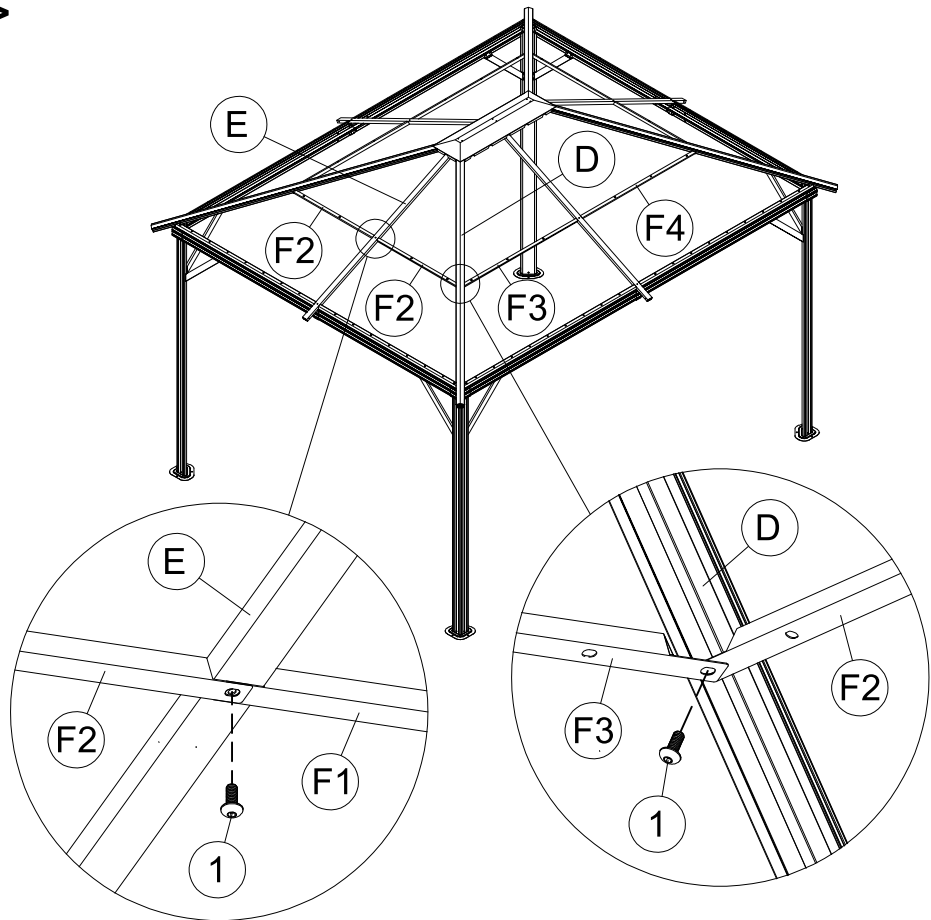

EN: Install in the same direction, do not tighten screws fully until all parts are connected.

DE: Installieren Sie in die gleiche Richtung und ziehen Sie die Schrauben nicht fest an, bis alle Teile angeschlossen sind.

ES: Instale en la misma dirección, no apriete los tornillos de manera completa hasta que todas las partes estén conectadas.

FR: Installez dans le même sens, ne serrez pas les vis à fond tant que toutes les pièces ne sont pas connectées.

IT: Installare nella stessa direzione, non stringere le viti completamente finché tutte le parti non sono state connesse.

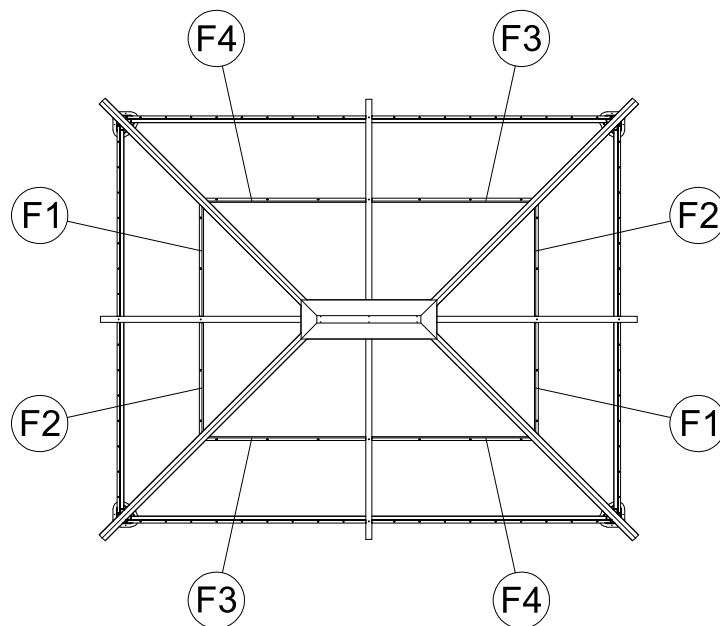

12

<11>

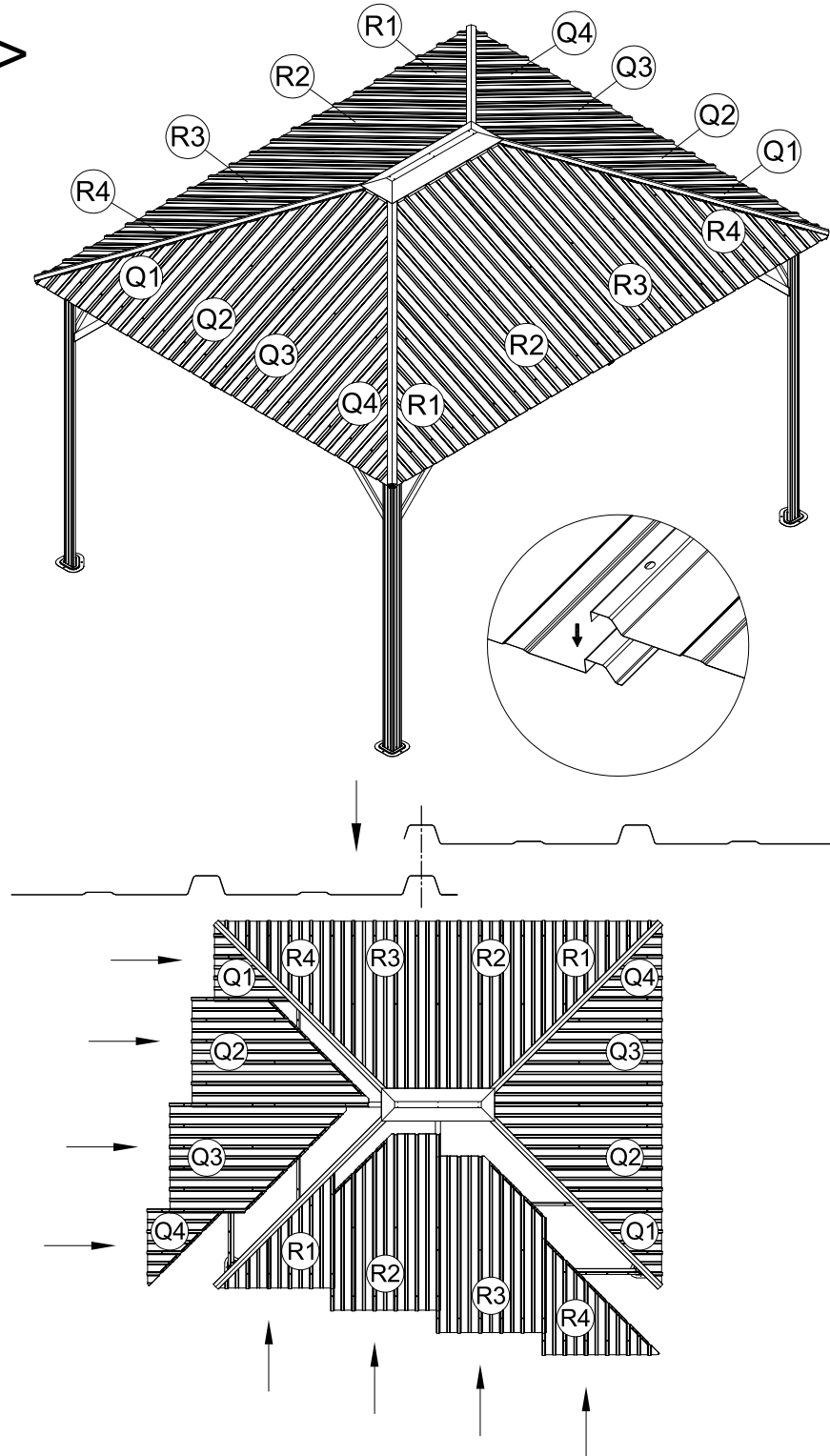

EN: This letter does not indicate the installation steps, just a schematic diagram of the iron plate distribution. The iron plate must be installed from left to right, not from right to left.

DE: Dieser Buchstabe gibt nicht die Installationsschritte an, sondern nur eine schematische Darstellung der Verteilung von Eisenplatten. Die Eisenplatte muss von links nach rechts und nicht von rechts nach links installiert werden.

ES: Esta letra no indica los pasos de instalación, sino un diagrama esquemático de la distribución de la placa de hierro. La placa de hierro debe ser instalada de izquierda a derecha, no puede ser de derecha a izquierda.

FR: Cette lettre n'indique pas les étapes d'installation, mais juste un schéma de la distribution des plaques de fer. La plaque de fer doit être installée de gauche à droite, et non de droite à gauche.

IT: Questa lettera non indica uno step di installazione, bensì un diagramma schematico della distribuzione della piastra in metallo.

La piastra in metallo va installata da sinistra a destra, e non da destra a sinistra.

<12>

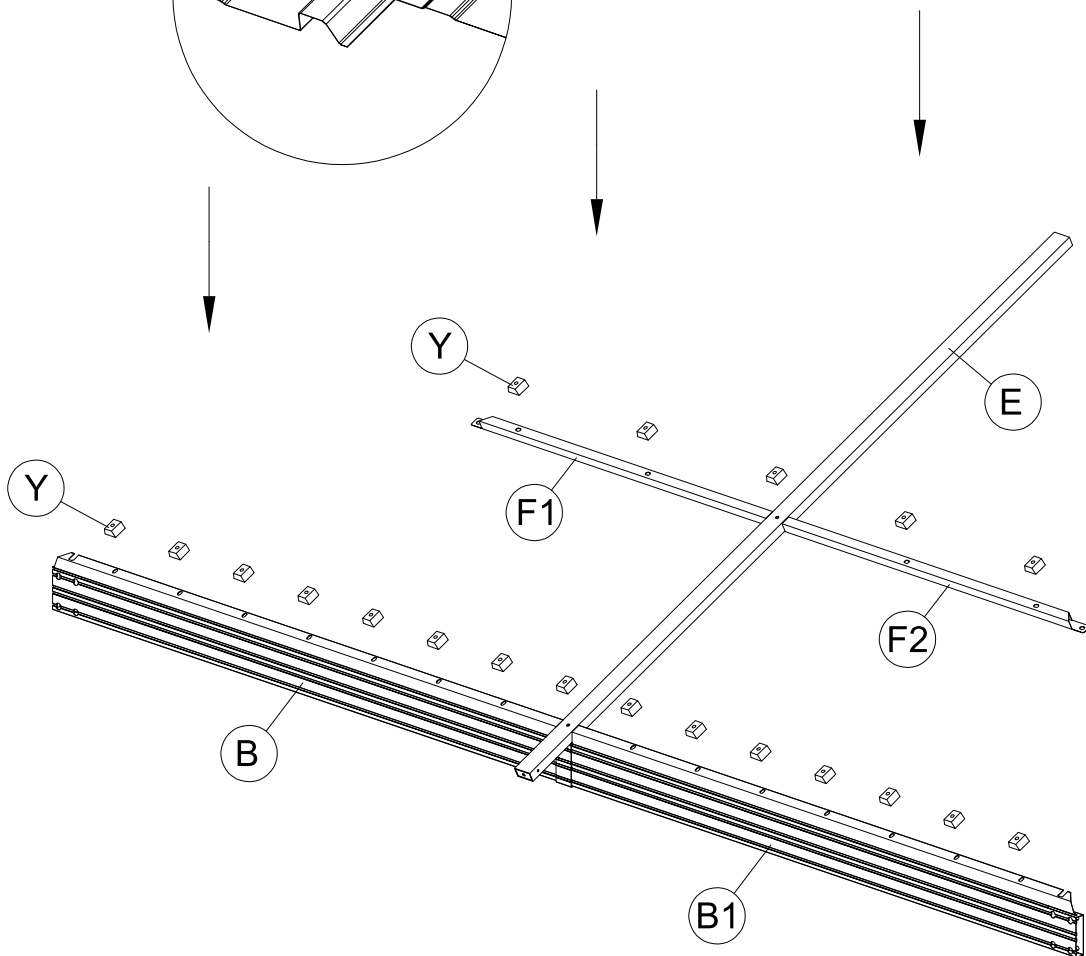
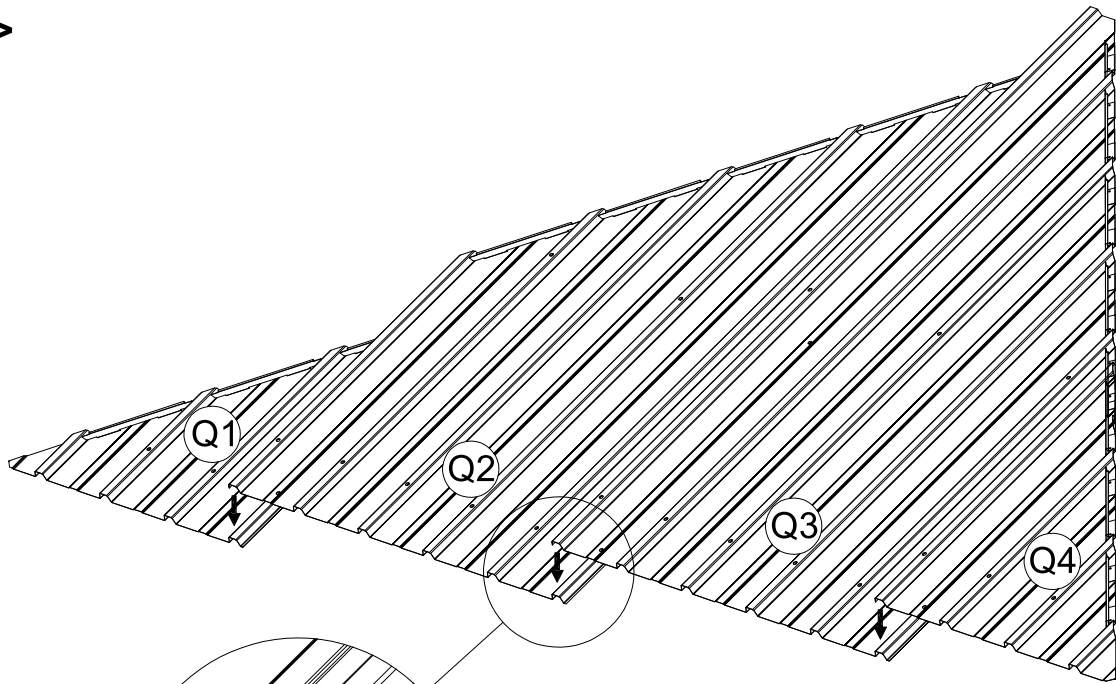

<13>

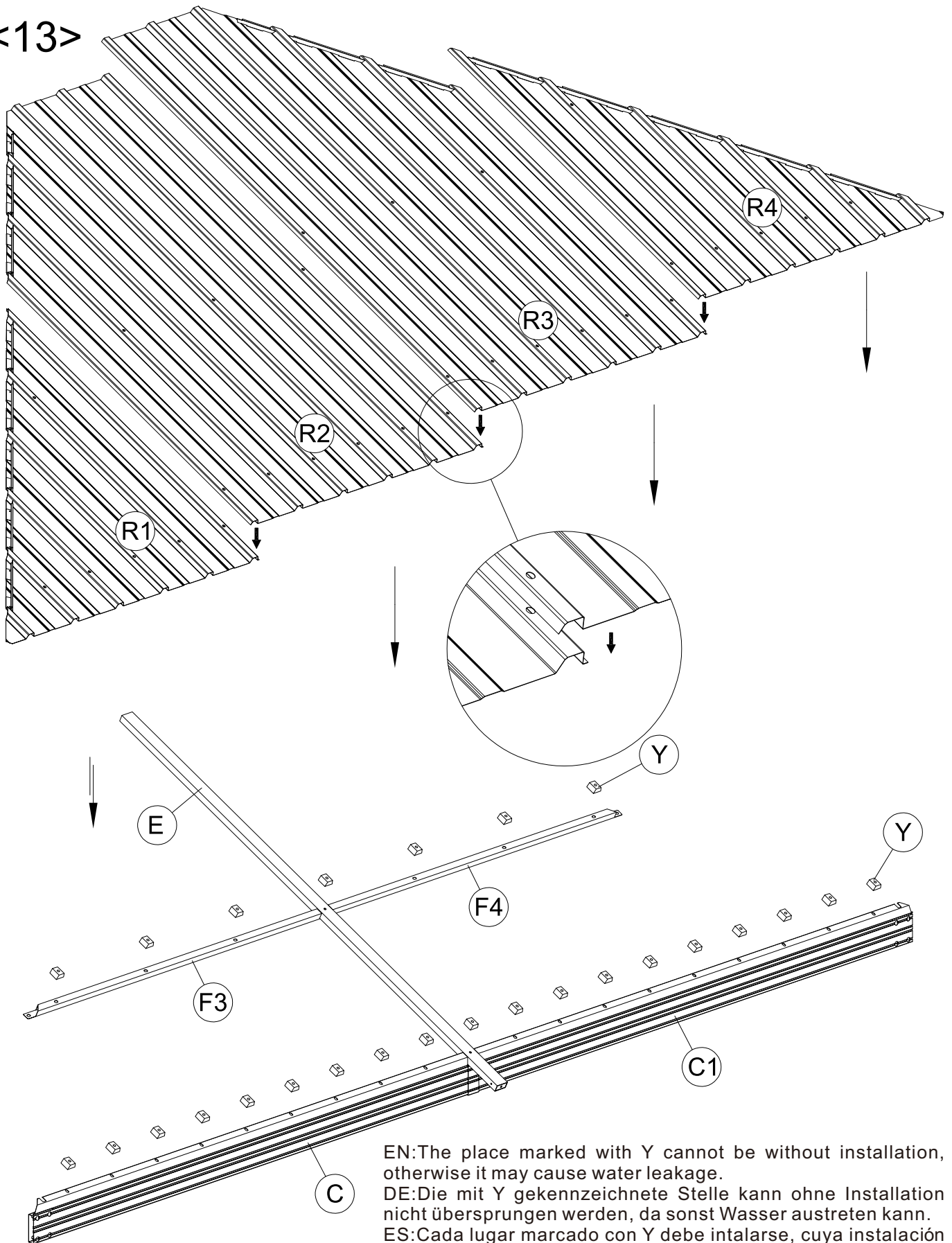

EN: The place marked with Y cannot be without installation, otherwise it may cause water leakage.

DE: Die mit Y gekennzeichnete Stelle kann ohne Installation nicht übersprungen werden, da sonst Wasser austreten kann.

ES: Cada lugar marcado con Y debe instalarse, cuya instalación no se puede omitir, de lo contrario puede causar fugas de agua.

FR: L'emplacement marqué d'un Y ne peut pas être sans installation, sinon il peut y avoir des fuites d'eau.

IT: La posizione marcata con la Y non può non essere installata, altrimenti questo potrebbe causare perdite.



<14>

Y 92x

8x

64x

M6x23

2 8x + 64x



M6x42

6 20x

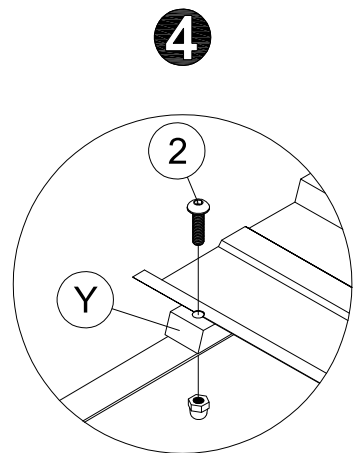
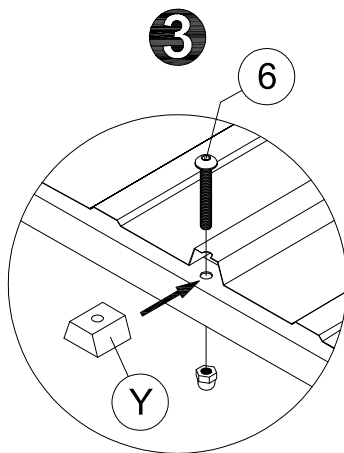
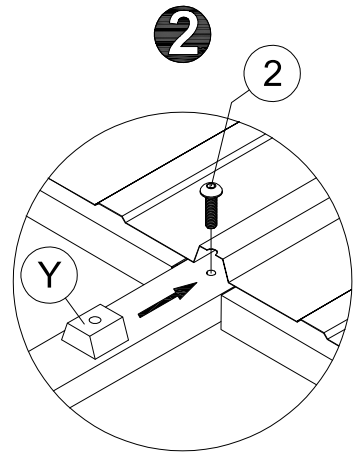
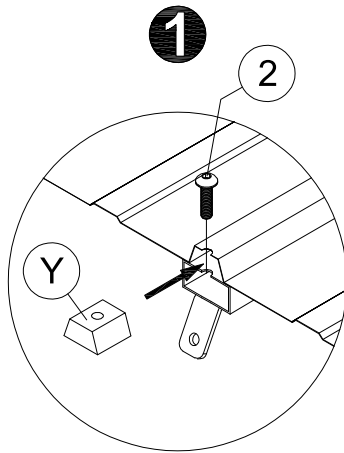
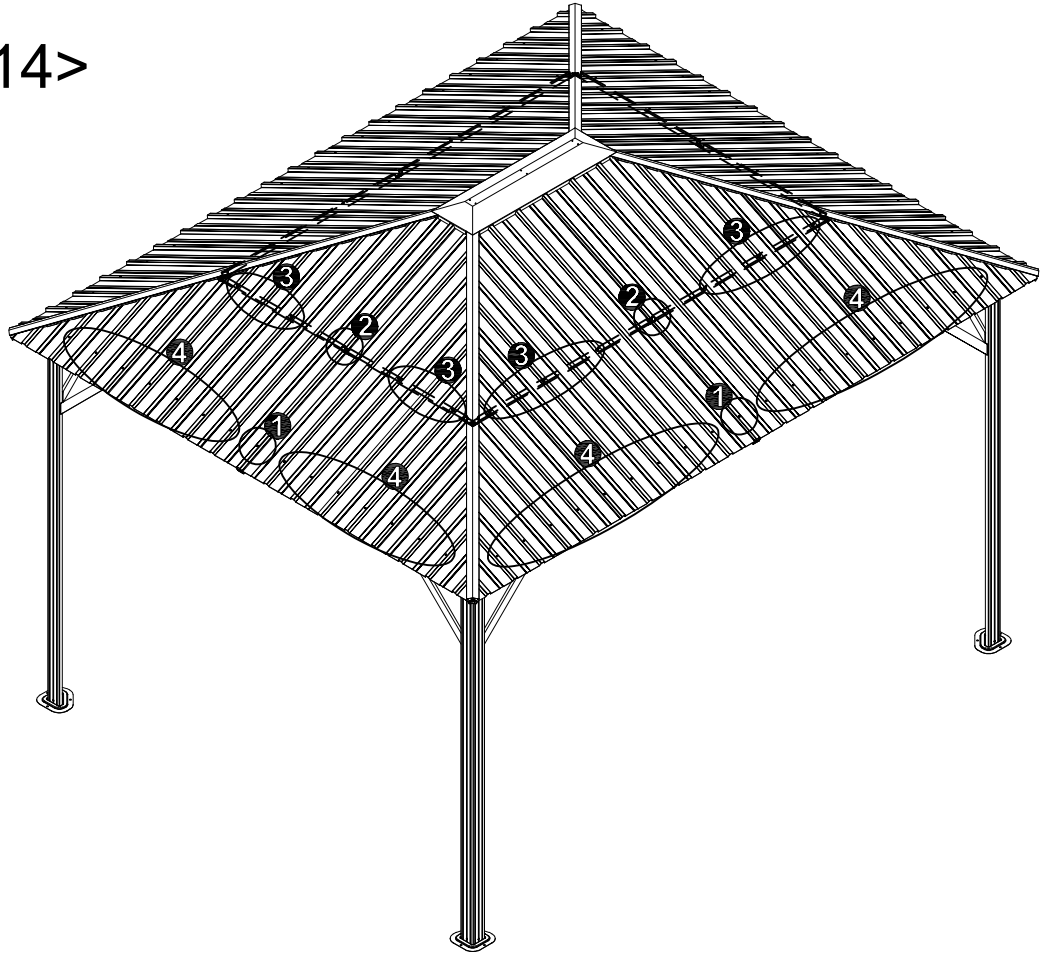

<15>

G1 2x

G2 2x

G3 2x

G4 2x

N 4x

N1 4x

1 8x M6x15

18

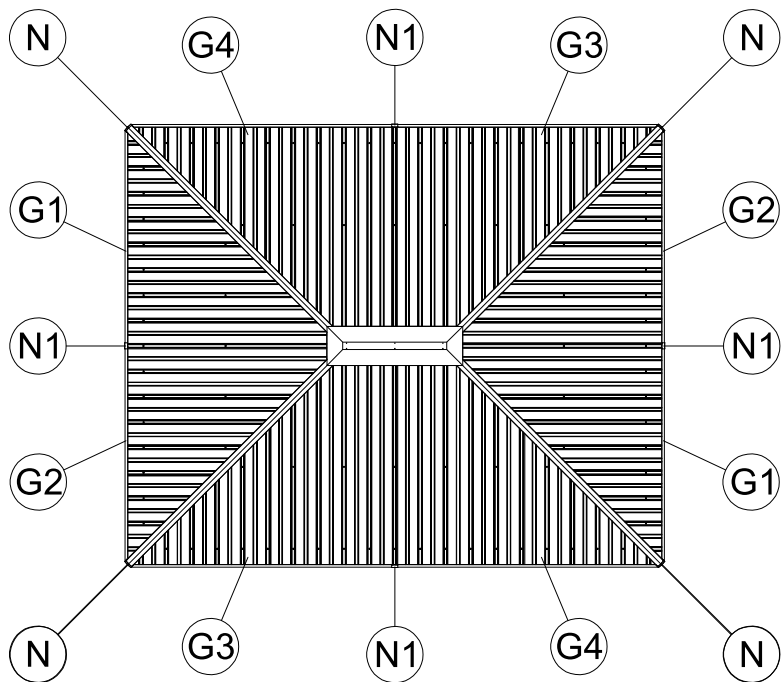
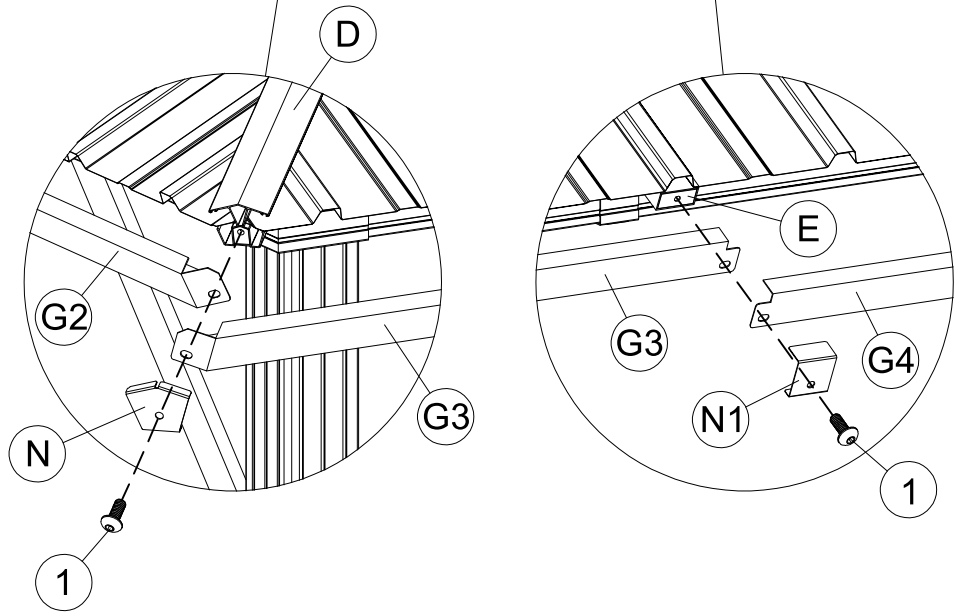

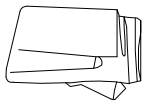

<16>

T 4x

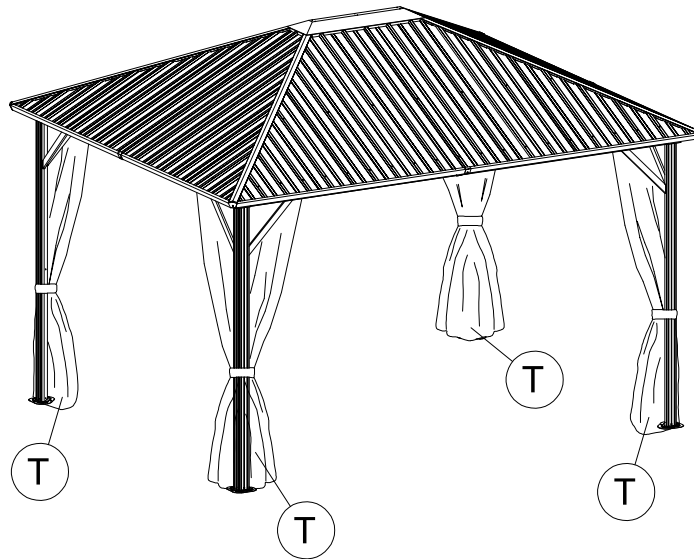
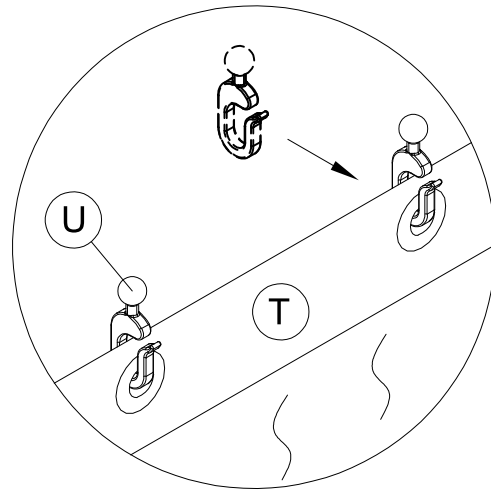
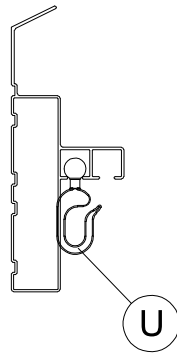

EN:1.S and T are divided into left and right directions, identification method: take apart the four zippers, and install S/T in a single piece.

The iron hook on S passes through the hole on T and hooks on the small hole of the upright.

2. There is no separate Bandage on T, the Bandage has been sewn on S.

DE:1.S und T sind in linke und rechte Richtung unterteilt. Identifikationsmethode: Nehmen Sie die vier Reißverschlüsse auseinander und installieren Sie S / T in einem Stück.

2. Der Eisenhaken an S geht durch das Loch an T und hakt an dem kleinen Loch des Pfostens.

2. Es gibt keinen separaten Verband auf T, der Verband wurde auf S genäht.

ES:1.S y T se dividen en direcciones izquierda y derecha, el método de identificación es siguiente: Desmontar las cuatro cremalleras e instalar S / T como una sola pieza.

2. El gancho de hierro en S pasa a través del orificio en T y se engancha en el pequeño orificio del poste.

No hay un vendaje separado en T, el vendaje se ha cosido en S.

FR:1.S et T sont divisés en directions gauche et droite, méthode d'identification : démontez les quatre fermetures éclair, et installez S / T en une seule pièce. Le crochet en fer sur S passe à travers le trou sur T et crochets sur le petit trou du montant.

2. Il n'y a pas de bandage séparé sur T, le bandage a été cousu sur S.

IT:1.S e T sono divisa tra direzione sinistra e destra, identificabili in questo modo: slacciare le quattro cerniere e installare S/T in un solo pezzo.

Il gancio in metallo su S passa attraverso il foro di T e si aggancia al piccolo foro del montante.

2. Non ci sono cinghie separate su T, la cinghia e' stata cucita su S.

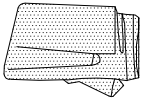

<17>

S 4x

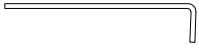

W 12x





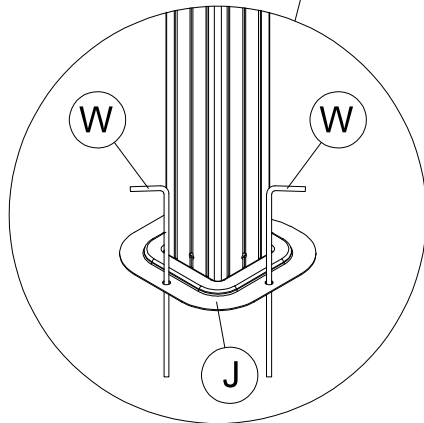
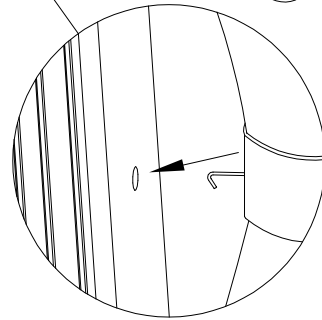
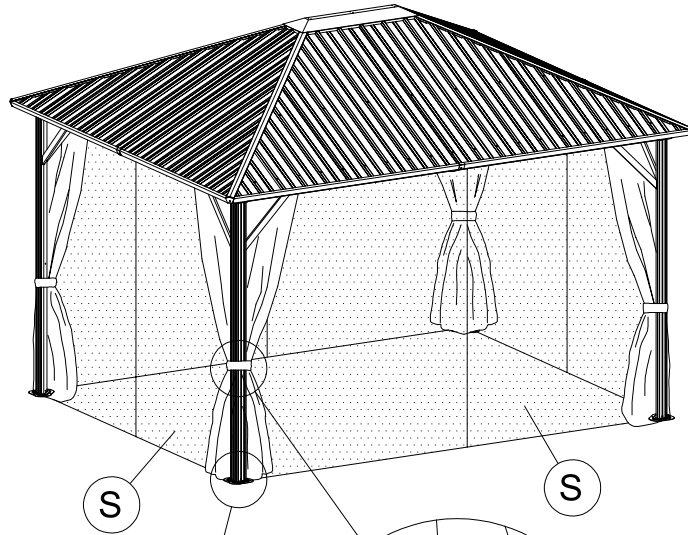
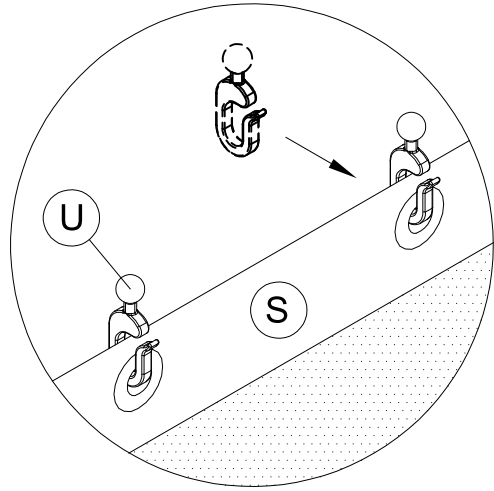
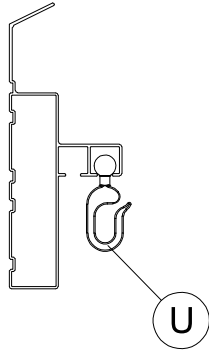



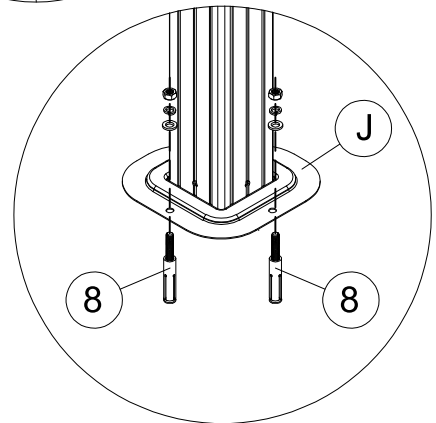







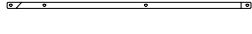



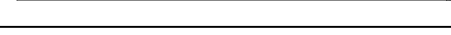
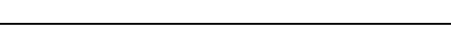
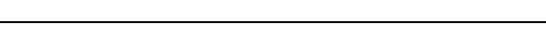
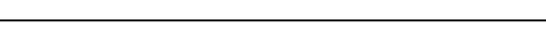
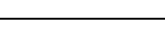



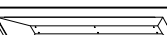
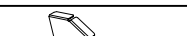





8 12x



or

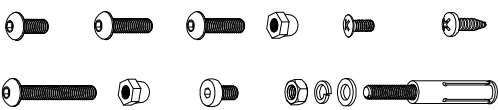

Carton-1/2	No	Reference Picture	Part	Qty
	1		A	4
	2		B	2
	3		B1	2
	4		C	2
	5		C1	2
	6		D	4
	7		E	4
	8		F1	2
	9		F2	2
	10		F3	2
	11		F4	2
	12		G1	2
	13		G2	2
	14		G3	2
	15		G4	2
	16		H1	4
	17		H2	4
	18		J	4
	19		K	4
	20		K1	4
	21		L	1
	22		M	1
	23		N	4
	24		N1	4
	25		P	4
	26		S	4
	27		T	4
28		U	104	

Carton-1/2	No	Reference Picture	Part	Qty
	29		V	4
	30		W	12
	31		Y	92
	32		Z	56
	33		Z1	8
	34		1,2,3,4, 5,6,7,8	287
	35			3

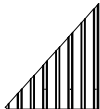
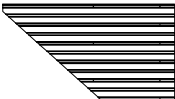
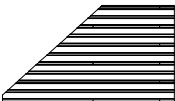
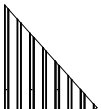
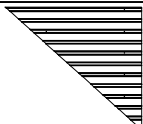
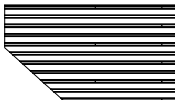
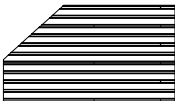
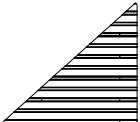
Carton-2/2	No	Reference Picture	Part	Qty
	1		Q1	2
	2		Q2	2
	3		Q3	2
	4		Q4	2
	5		R1	2
	6		R2	2
	7		R3	2
	8		R4	2

US



001-877-644-9366
customerservice@aosom.com

CA



001-855-537-6088
customerservice@aosom.ca

UK



0044-800-240-4004
enquiries@mhstar.co.uk

DE



0049-(0)40-88307530
service@aosom.de

FR



0033-1-84166106
contact@aosom.fr

ES



0034-931294512
atencioncliente@aosom.es

IT



0039-0249471447
clienti@aosom.it