

Part List

DO NOT RETURN PRODUCT IF YOU ARE MISSING PARTS. PLEASE CALL: 1 (800) 972-6130

No.	Part #	Qty	Description
1	1000198	2	Felt Washer
2	1017350	1	Hopper Bottom Plate
3	1000203	1	Hopper Bottom Bearing
4	1008244	1	Rate Gate
5	1001521	4	Guide, Rate Gate/Accuway
6	1005211	1	Spinner Plastic Lg Black
7	1008078	1	Axle, Spinner
8	1000054	1	Roll Pin 1/8 x 7/8
9	1006084	6	Bolt, HexHd, SS: 1/4"-20 x 3/4
10	1017543	2	Plate, Linkage
11	1005198	6	Nut, NylonLock, SS: 1/4"-20
12	1017541	1	Bracket, Linkage
13	1017542	1	Spring, linkage
14	1017364	1	Control Linkage
17	1001255	2	Screw, HexHd, SS: 1/4"-20 x 1"
18	1008270	1	Linkage, Round
21	1017553	1	Bracket, Angle
23	1000844	1	Agitator Blade Weldment
24	1001273	1	Hairpin (299 Agitator) SS
25	1001301	2	3/8 Spinner Shaft Bushing
26	1001518	1	Pinion Gear - Metal
27	1000053	1	Roll Pin 1/8 x 3/4
28	1001299	2	Gearbox Bushing 5/8"
29	1001516	1	Bevel Gear-metal
30	1005389	1	Nylon Spacer, Pin Retain
31	1001304	1	Dowel Pin, SS: 3/16 x 1
32	1008085	1	Axle, Wheel
33	1005336	1	Gear Box Cover Front
34	1005337	1	Gear Box Cover Rear
35	1017710	8	Bolt, PhlpHd, SS 10-24 x 5/8"
36	1005368	1	Grease Zerk 1/4 Drive IN
37	1001308	8	Nut, NylonLock, #10-24 SS
38	1000225	2	Handle Grip
39	1017620	1	Weldment, Handle
45	1017626	3	Label, Reflective
47	1000000	1	On-off Decal
50	1017544	1	Rod, Linkage
52	1017618	1	Handle, Lower
54	1008811	2	Bolt; Hex, 5/16"-18 x 1 SS316
56	1017504	2	Cap, Plastic
57	L-1744-6	1	Label, Serial#, Spyker
58	1017328	1	Large Frame Weldment, SS
61	1019997	2	Bearing, Axle
62	1017329	1	Stand, Large Frame (SS)
65	1001607	2	Wheel, 12" Drive/Idle
66	1018797	1	Manual
67	1017579	1	Cover, Hopper 100#
68*	1017547	1	Screen, 100#
69	1017540	1	Hopper

No.	Part #	Qty	Description
70	1017709	1	Decal Spyker Ice
76	1018993	4	Spacer, Plastic
77	1018706LH	1	Mounting Bracket, LH
78	1018706RH	1	Mounting Bracket, RH
79	1018708	4	Stiffener Plate
81	1018738	2	Spring
82	1018740	2	External Tooth Lockwasher
83	1001255	2	Bolt, HexHd, SS: 1/4"-20 x 1"
84	1004975	2	Nut, 1/4-20 Hex Flange
85	1007386	2	Bolt, Carriage, SS: 1/4"-20 x 3/4"
86	1019001	2	Bolt, HexHd: 1/4"-20 x 1-3/4"
87	1019367	1	Deflector w/ Label







*(68) Larger hole, S/S screen available on Spyker.com

No.	Part #	Qty	Description
	1018576	1	Parts Bag
11	1005198	10	Nut, NylonLock, SS: 1/4"-20
15	1001533	1	Nylon Flange Bushing
16	1001351	3	Washer, SS: 1/4"
19	1017555	1	Nut, 5/16"-18
20	1017554	1	Washer, Lock: 5/16"
22	1001315	3	Nut, NylonLock: 5/16"-18
40	1001262	5	Bolt, HexHd, SS: 1/4"-20 x 1-1/2"
41	1001554	1	Washer, Nylon
44	1017346	1	Spring, Control Lever
46	1017552	1	Gauge, Winter
48	1007888	4	Bolt, HexHd: 1/4"-20 x 2-1/4"
49	1017371	1	Bolt, HexHd, SS: 1/4"-20 x 3-1/4"
51	1017624	1	Plate, Guide
53	45M1111SS	2	Washer, Flat, SS: 5/16"
55	1017374	2	Bolt, Carriage, 5/16"-18 x 3/4"
59	1005414	1	Rue Ring Locking Pin
60	1001350	5	Washer, Flat SS
63	1001274	1	Clevis Pin, 3/16 x 1-3/4
64	1019596	1	Cotter Ring
71	1017225	2	Lockwasher, 5/16: ext.int tooth
72	1017722	1	Carriage Bolt, 6mm x 40 mm
73	1017723	1	Spacer
74	1017724	1	Washer; External Tooth M6
75	1007575	1	Knob
CONTROL LEVER ASSEMBLY:			
11	1005198	1	Nut; Nylon Lock 1/4" -20
40	1001262	1	Bolt; Hex Head 1/4" -20 x 1-1/2"
41	1001554	2	Nylon Washer
42	1007828	2	Handle Knob
43	1017345	1	Control Lever

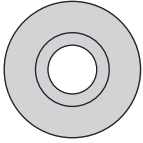
Hardware Identifier

ILLUSTRATIONS ON THIS PAGE ARE TO SCALE FOR FASTER IDENTIFICATION OF HARDWARE DURING ASSEMBLY.

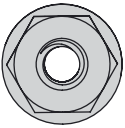
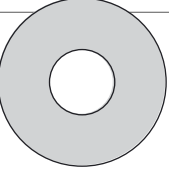
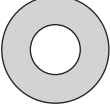
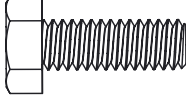
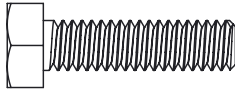
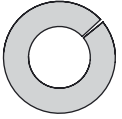
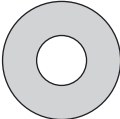
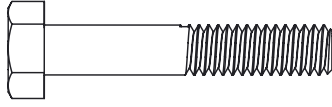
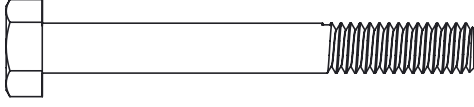
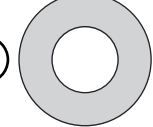
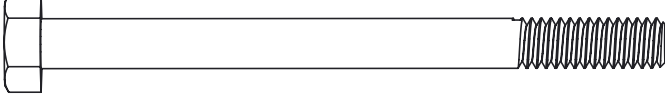
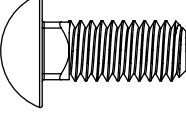
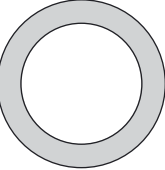
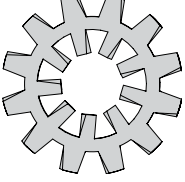
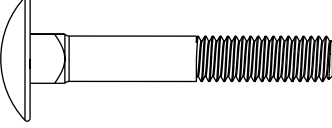
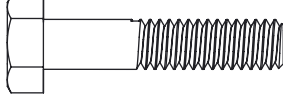
DO NOT RETURN PRODUCT IF YOU ARE MISSING PARTS. PLEASE CALL: 1 (800) 972-6130

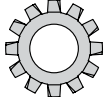
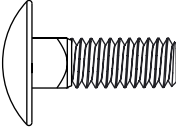
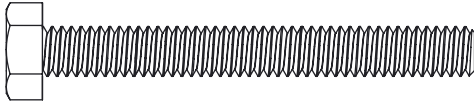
 <p>11</p> <p>Nut: Nylon Lock 1/4" - 20 (x10) 1005198</p>	 <p>15</p> <p>Flange Bushing Nylon (x1) 1001533</p>	 <p>19</p> <p>Nut 5/16" - 18 (x1) 1017555</p>	 <p>22</p> <p>Nut: Nylon Lock 5/16" - 18 (x3) 1001315</p>	 <p>37</p> <p>Nut: Nylon Lock SS: #10 - 24 (x8) 1001308</p>	 <p>84</p> <p>Nut: Hex Flange 1/4" - 20 (x2) 1004975</p>
 <p>1</p> <p>Washer; Felt (x2) 1000198</p>	 <p>16</p> <p>Washer; SS 1/4" (x3) 1001351</p>	 <p>9</p> <p>Bolt: Hex Head, SS 1/4" -20 x 3/4" (x3) 1006084</p>		 <p>17</p> <p>Screw: Hex Head, SS 1/4" -20 (x1) 1001255</p>	
 <p>20</p> <p>Washer; Lock 5/16" (x1) 1017554</p>	 <p>41</p> <p>Washer Nylon (x1) 1001554</p>	 <p>40</p> <p>Bolt: Hex Head, SS 1/4" -20 x 1-1/2" (x5) 1001262</p>		 <p>48</p> <p>Bolt: Hex Head, SS 1/4" -20 x 2-1/4" (x4) 1007888</p>	
 <p>53</p> <p>Washer; Flat SS 5/16" (x2) 45M1111SS</p>	 <p>49</p> <p>Bolt: Hex Head, SS 1/4" -20 x 3-1/4" (x1) 1017371</p>		 <p>55</p> <p>Bolt: Carriage 5/16" -18 x 3/4" (x2) 1017374</p>		
 <p>60</p> <p>Washer; Flat SS (x5) 1001350</p>	 <p>71</p> <p>Lock Washer: 5/16" Ext / Int Tooth (x2) 1017225</p>	 <p>72</p> <p>Bolt: Carriage 6mm x 40mm (x1) 1017722</p>		 <p>83</p> <p>Bolt: Hex Head, SS 1/4" -20 x 1-1/4" (x2) 2M0820SS</p>	
 <p>74</p> <p>Washer: External Tooth M6 (x1) 1017724</p>	 <p>82</p> <p>Lock Washer, SS: 1/4 8-18 External Tooth (x2) 1018740</p>	 <p>85</p> <p>Bolt: Carriage, SS 1/4" -20 x 3/4" (x2) 1007386</p>		 <p>86</p> <p>Bolt: Hex Head, SS 1/4" -20 x 1-3/4" (x2) 1019001</p>	

* Exterior circumference of washers can vary. These dimensions are a measurement of the internal diameter of the washer.



Part Explosions

DO NOT RETURN PRODUCT IF YOU ARE MISSING PARTS. PLEASE CALL: 1 (800) 972-6130

RATE GATE + AXLE / SPINNER

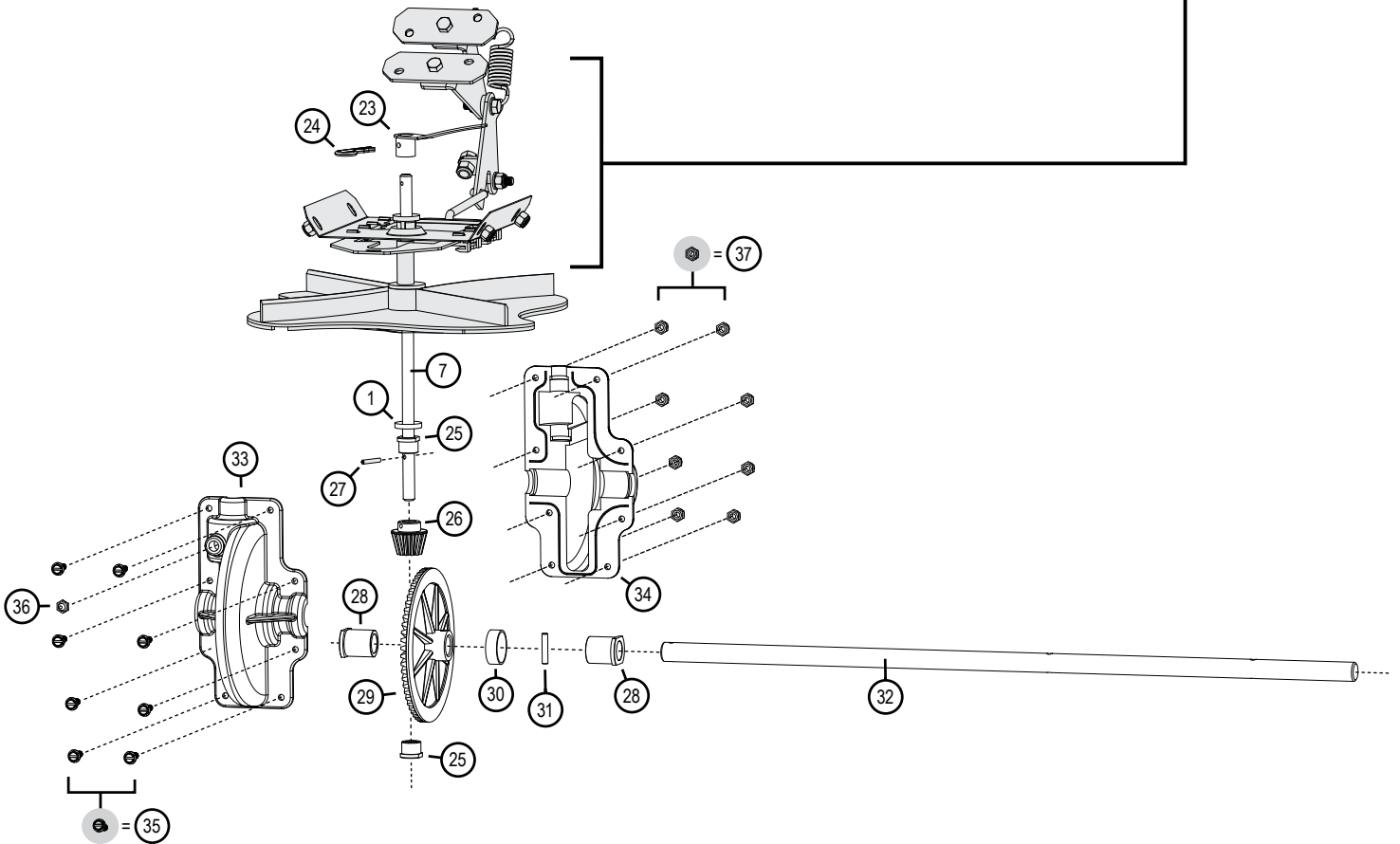
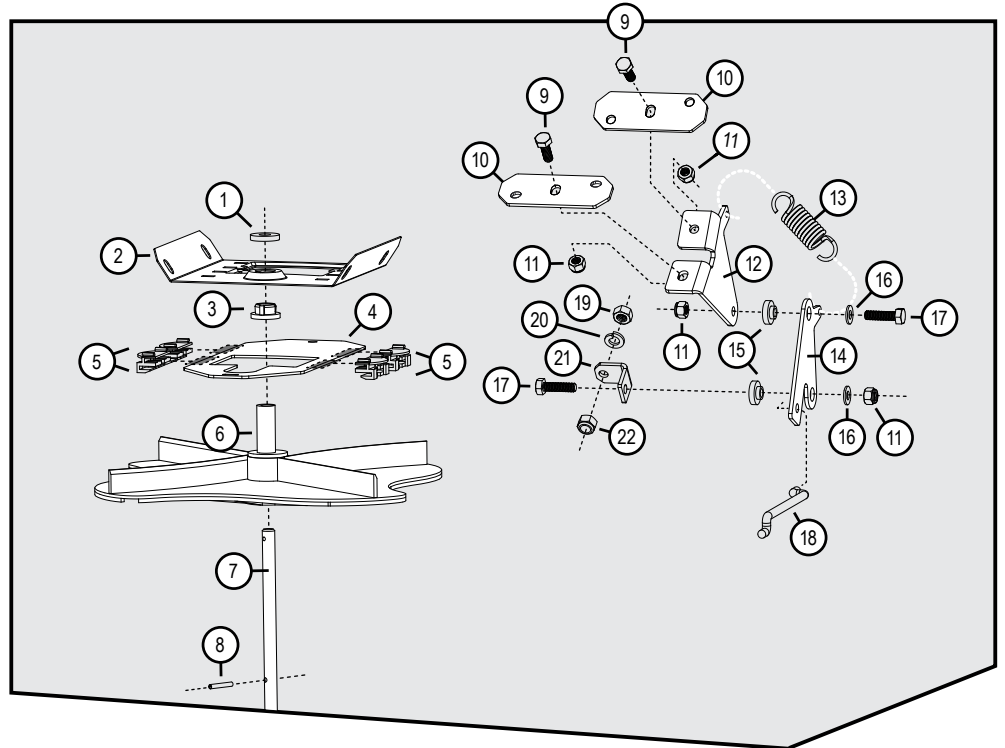
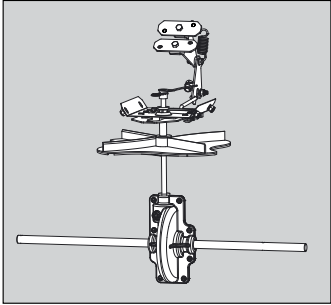

FRAME & HANDLE

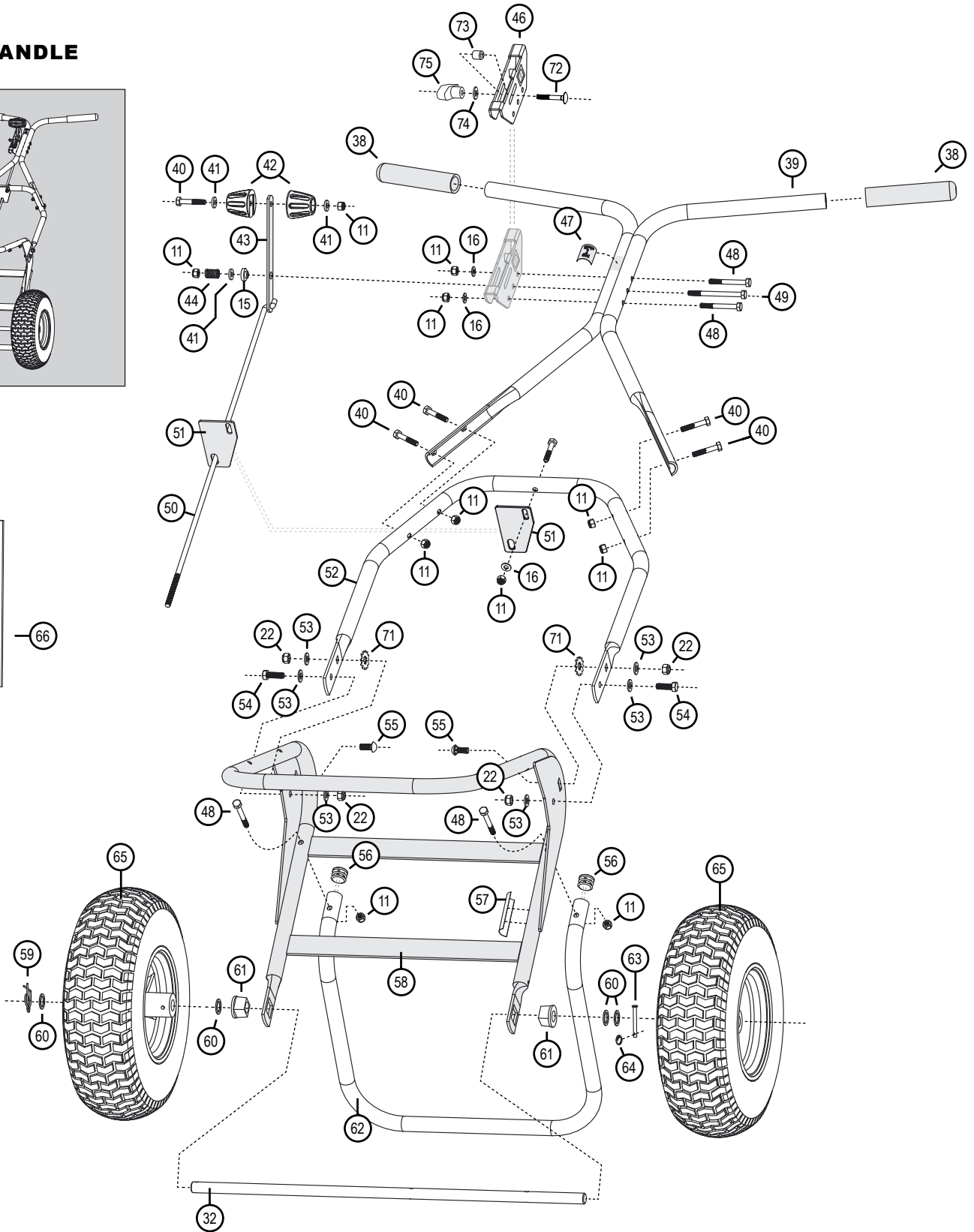
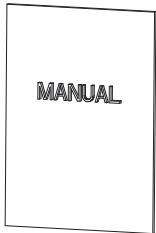
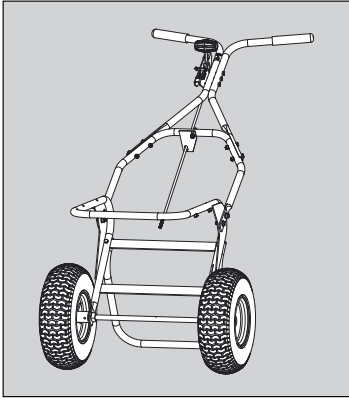

DO NOT RETURN PRODUCT IF YOU ARE MISSING PARTS. PLEASE CALL: 1 (800) 972-6130

HOPPER

