

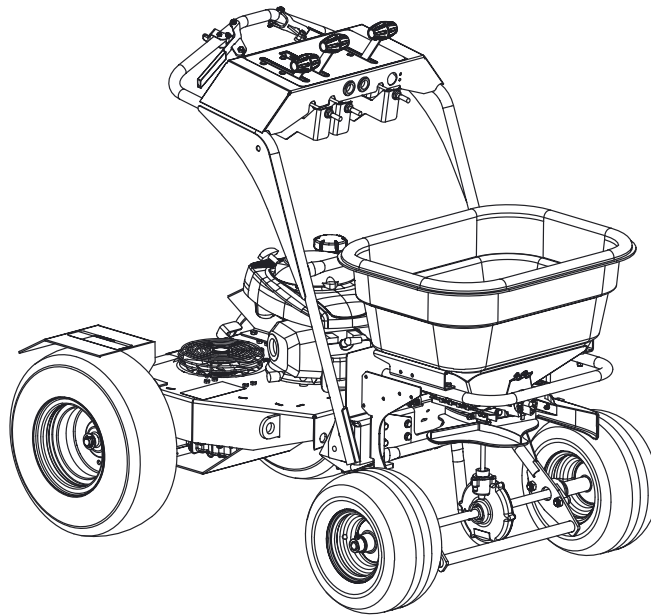

# PARTS MANUAL

## ROS 5 Model S100-12011 Ride-On Spreader



Spyker Spreaders  
Contact Us at 800.972.6130

**▲ IMPORTANT**

**This manual contains information for the safety of persons and property.  
Read it carefully before assembly and operation of the equipment!**

# SULKY ASSEMBLY

## SECTION 1

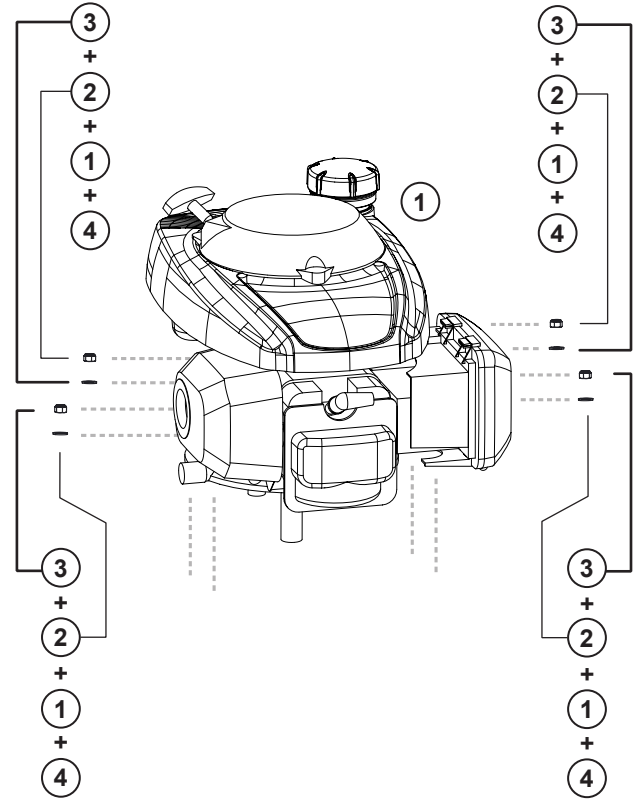

### SULKY

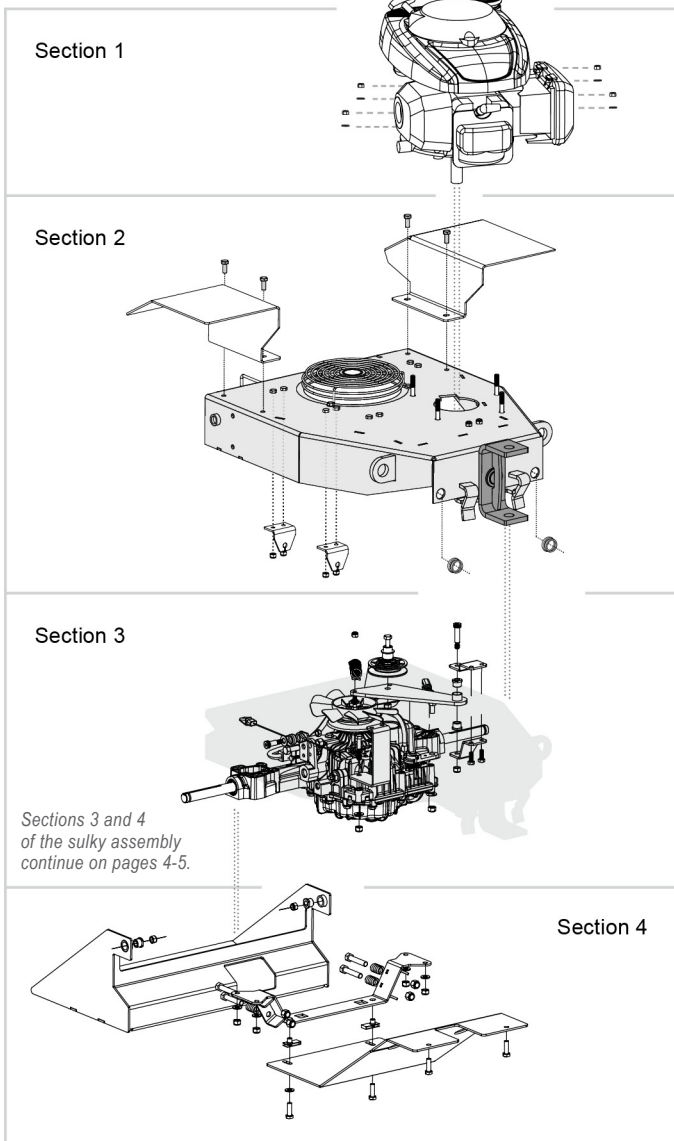

Item #	Name & Part No.	Qty.
1	<b>Engine</b> 1017221	1
2	<b>5/16" Washer</b> 45M1111P	19
3	<b>5/16" Nylon Lock Nut</b> B-4786	20

Item #	Name & Part No.	Qty.
4	<b>Sulky</b> 1017365	1
5A	<b>Fender, Left Side</b> 1018613	1
5B	<b>Fender, Right Side</b> 1018614	1
6	<b>Bolt, Hex Head 5/16 x 3/4</b> 2M1012P	4
7	<b>Nut, Whiz Lock 5/16 x 18</b> B-4355	4

# SULKY ASSEMBLY

## SECTION 2

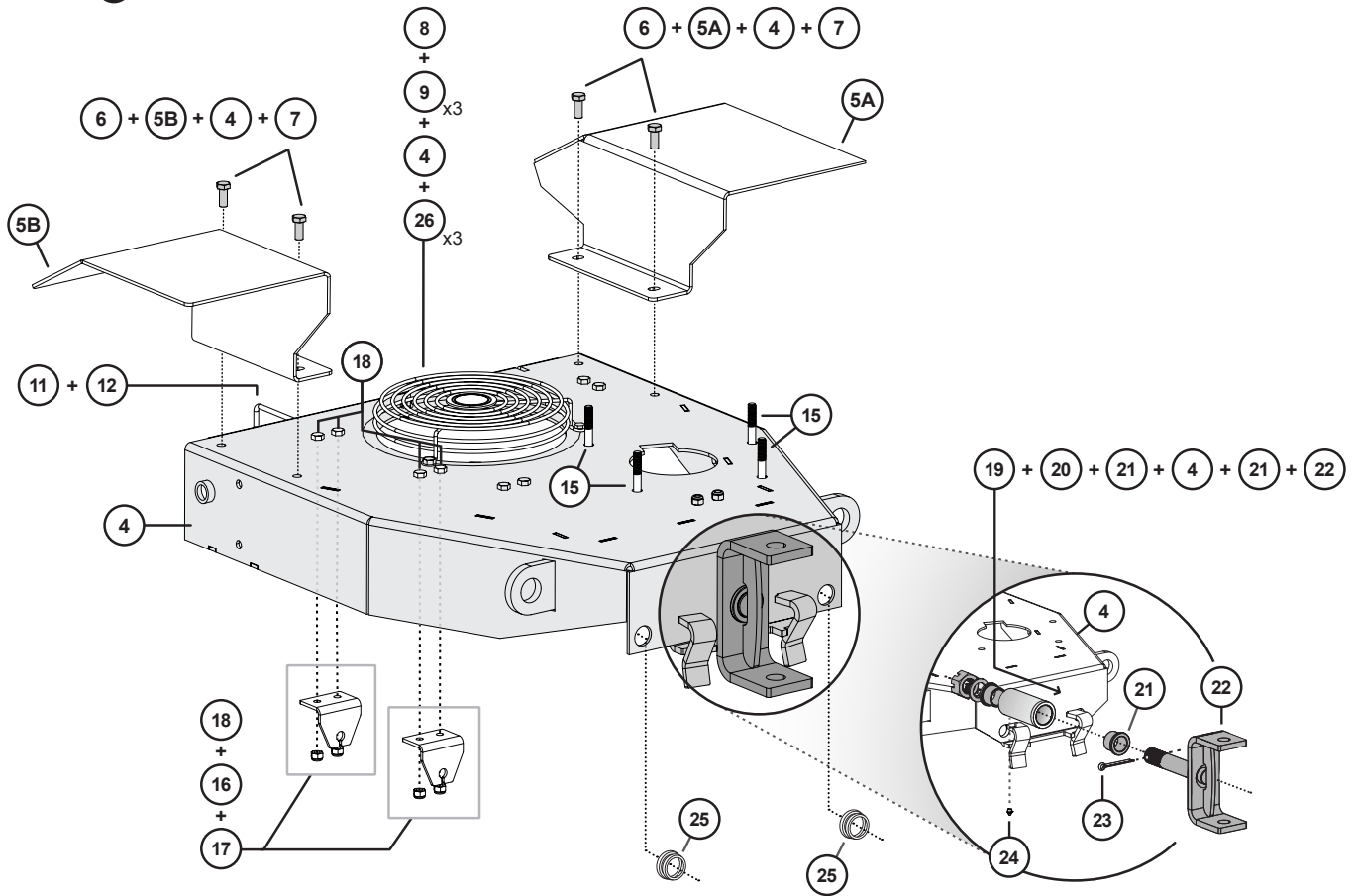

Item #	Name & Part No.	Qty.
8	Fan Guard 1008794	1
9	Bolt, Hex Head 10 x 5/8 SS 1001248	8
10	Nut, Nylon Lock #10-24 SS 1001308	9
11	Formed Rod, Bypass 1016772-01	1
12	Nut, Push 3/16 OD Shaft 1017034	1
13	Bolt Shoulder 3/8 x 1.25 x 5/16-18 1009093	3
14	3/8 Spinner Shaft Bushing 1001301	6
15	Bolt, Hex Head 5/16 x 1-3/4 2M1028P	5
16	Cable Bracket 1008886-10	2
17	Nut, Nylon Lock 1/4-20 B-4785	12

Item #	Name & Part No.	Qty.
18	Bolt, Hex Head 1/4 x 3/4 2M0812P	10
19	Slotted Nut 1" x 8 UNC 1008982	1
20	Bushing, Mach 1" V-886	1
21	Flange Bearing 1008797	2
22	Clevis Pivot Weldment 1008887-10	1
23	Cotter Pin 3/16 x 2 SS18-8 1008983	1
24	Grease Zerk 1/4-28 1001763	2
25	Small Grommet 1010164	2
26	Push Nut 1018590	3

# SULKY ASSEMBLY

## SECTION 3

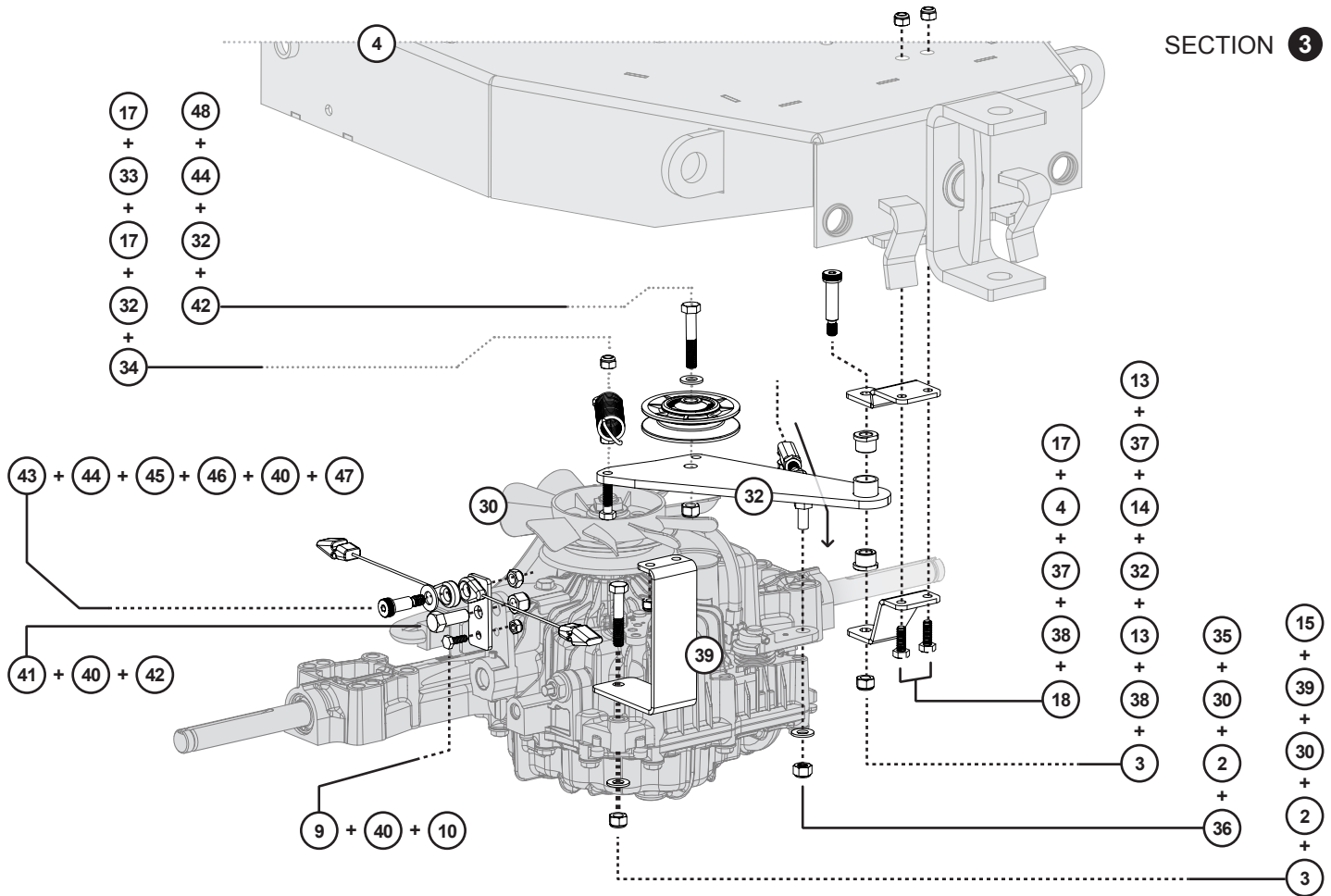

Item #	Name & Part No.	Qty.
30	Transmission, Tuff Torq 1016754	1
31	Pulley, Idler 1018591	1
32	Weldment, Idler Pulley 1010027	1
33	Spring 1018592	1
34	Bolt, Hex Head 1/4 x 1 2M0816P	1
35	Linkage Assembly 1017031	1
36	Nut, Nylon Lock 5/16 - 24 1009428	2
37	Bracket, Tensioner 1017033-10	1
38	Bracket, Tensioner 1016771-10	1
39	Front Transmission Mount 1016759-10	1

Item #	Name & Part No.	Qty.
40	Bracket, Plate 1017068-10	1
41	Bolt, Hex Head 3/8 x 1 2M1216P	1
42	Nut, Nylon Lock 3/8 - 16 B-4820	6
43	Bolt Shoulder 3/8 x 3/4 x 5/16 - 18 1017069	1
44	Washer, SAE Flat 3/8 45M1313P	2
45	Cable, Reverse 1008926	1
46	Cable, Forward 1008925	1
47	Nut, Lock 5/16 - 18 B-1674P	3
48	Bolt, Hex Head 3/8 x 1-3/4 2M1228P	1

# SULKY ASSEMBLY

## SECTION 4

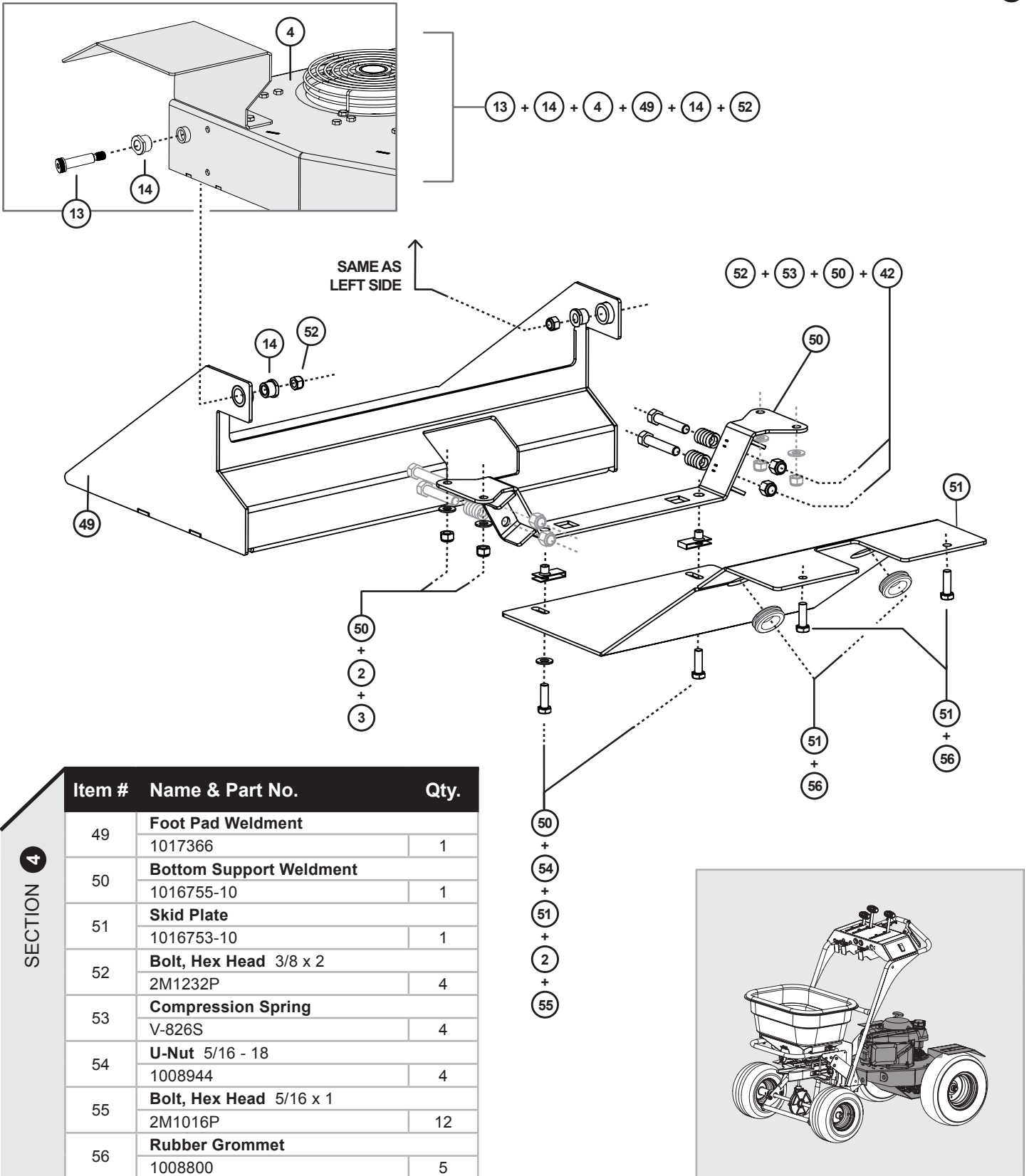

### SECTION 4

Item #	Name & Part No.	Qty.
49	<b>Foot Pad Weldment</b> 1017366	1
50	<b>Bottom Support Weldment</b> 1016755-10	1
51	<b>Skid Plate</b> 1016753-10	1
52	<b>Bolt, Hex Head 3/8 x 2</b> 2M1232P	4
53	<b>Compression Spring</b> V-826S	4
54	<b>U-Nut 5/16 - 18</b> 1008944	4
55	<b>Bolt, Hex Head 5/16 x 1</b> 2M1016P	12
56	<b>Rubber Grommet</b> 1008800	5



# TRANSMISSION ASSEMBLY



## SECTION 1

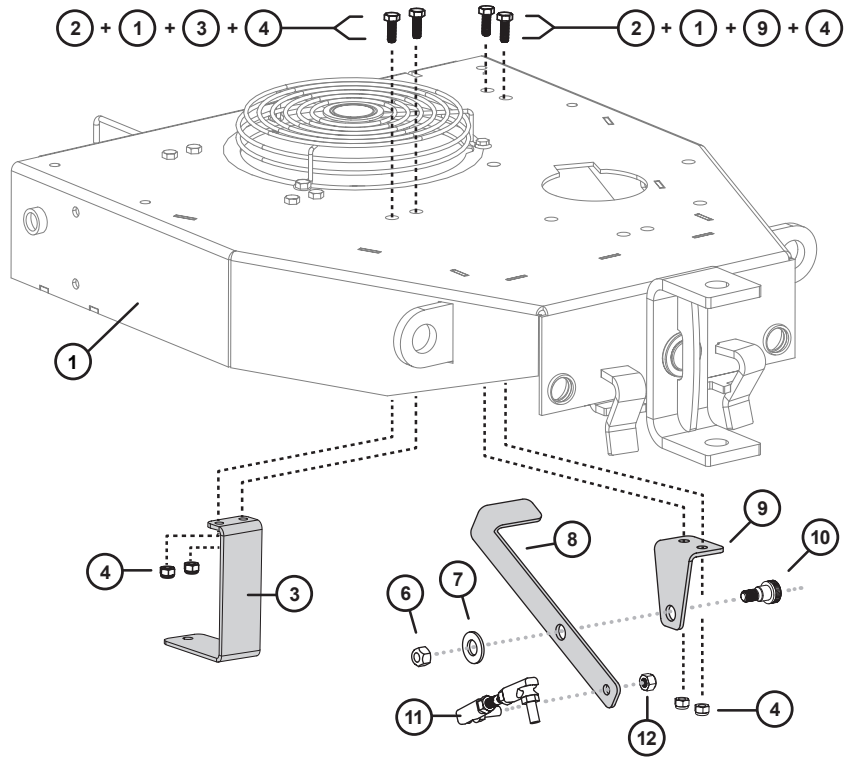

## TRANSMISSION

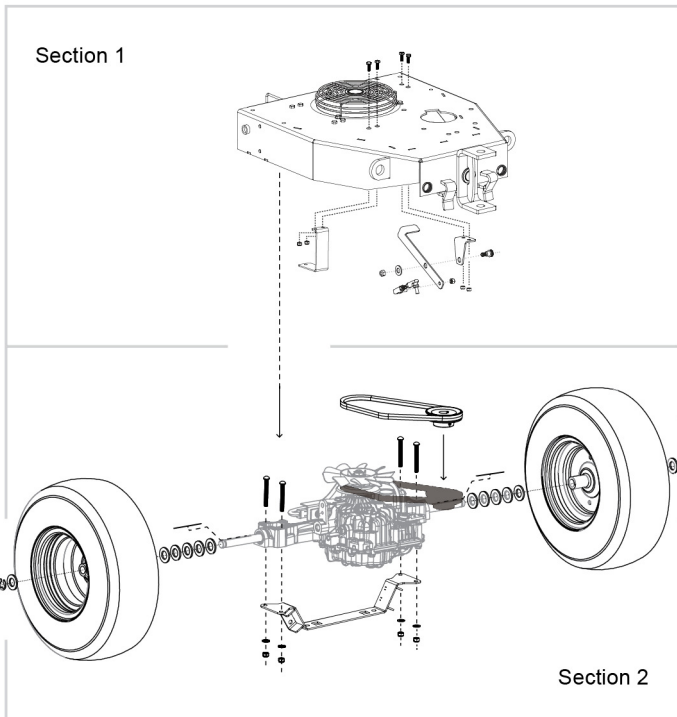

Item #	Name & Part No.	Qty.
1	<b>Sulky</b> 1017365	1
2	<b>Bolt, Hex Head 1/4 x 3/4</b> 2M0812P	10
3	<b>Front Transmission Mount</b> 1016759-10	1
4	<b>Nut, Nylon Lock 1/4-20</b> B-4785	12
5	<b>Shoulder Bolt 3/8 x 1.25 x 5/16-18</b> 1009093	3
6	<b>Nut, Hex Lock 3/8-16</b> B-1675P	1
7	<b>Washer, Flat 1/2"</b> 45M1717P	1
8	<b>Brake Lever</b> 1016765-01	1
9	<b>Brake Bracket</b> 1016766-10	2
10	<b>Bolt, Shoulder 0.5 x 3/8-16</b> 1008844	1
11	<b>Linkage Assembly</b> 1017031	1
12	<b>Nut, Nylon Lock 5/16 - 24</b> 1009428	4

# TRANSMISSION ASSEMBLY

## SECTION 2

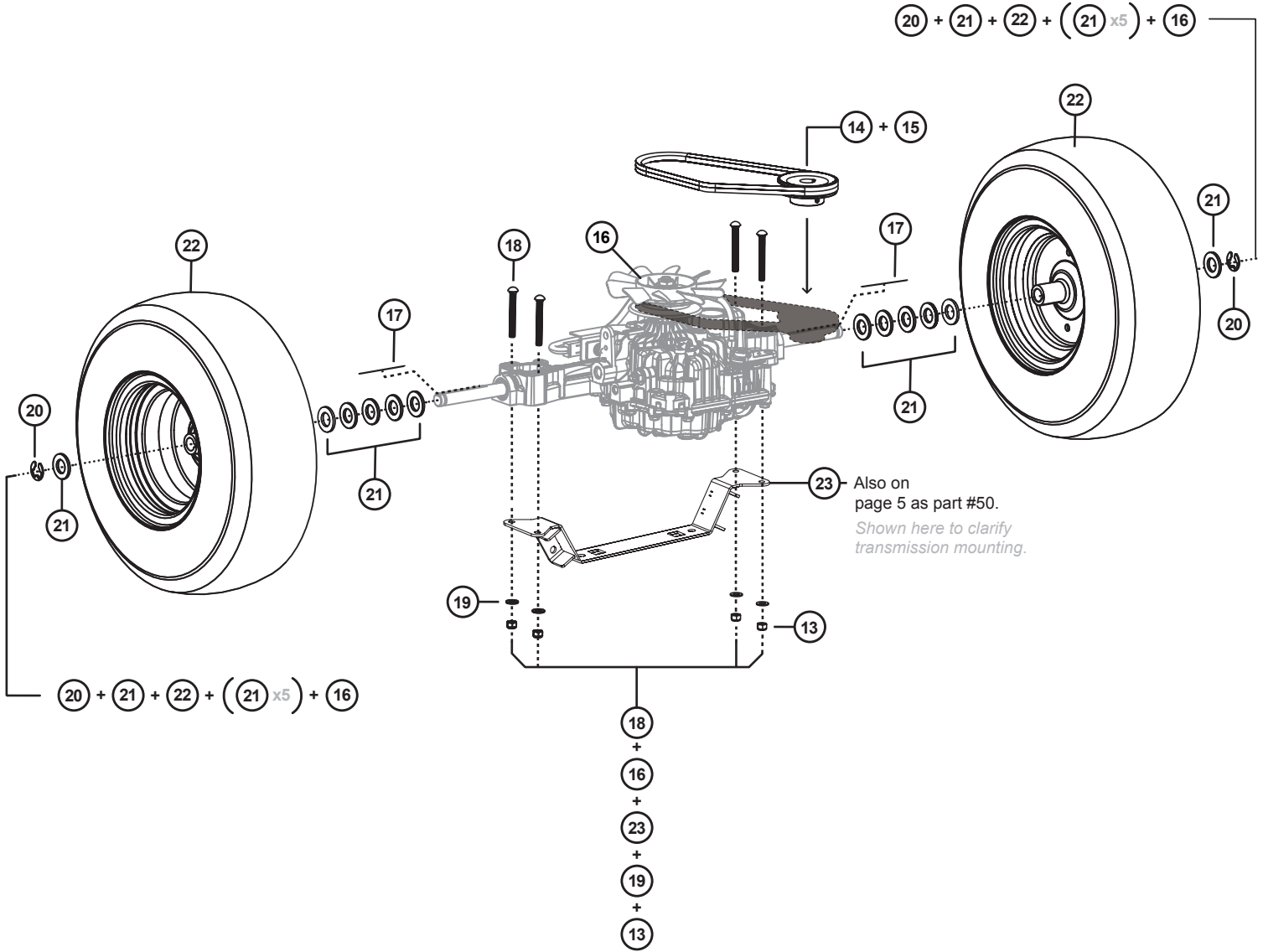

Item #	Name & Part No.	Qty.
13	Nut, Nylon Lock 5/16-18 B-4786	21
14	V-Belt 1016788	1
15	Drive Pulley 1016787	1
16	Tuff Torq Transmission 1016754	1
17	Square Key 1008849	2
18	Carriage Bolt 5/16-18 x 2.75 1008801	4

Item #	Name & Part No.	Qty.
19	Washer, Flat 5/16 45M1111P	19
20	Retaining Ring 3/4" E Type B-4305	2
21	Washer, Flat 3/4 45M2525P	13
22	Rear Wheel Assembly 1008846	2
23	Bottom Support Weldment 1016755-10	1

# FRONT FRAME & HOPPER ASSEMBLY

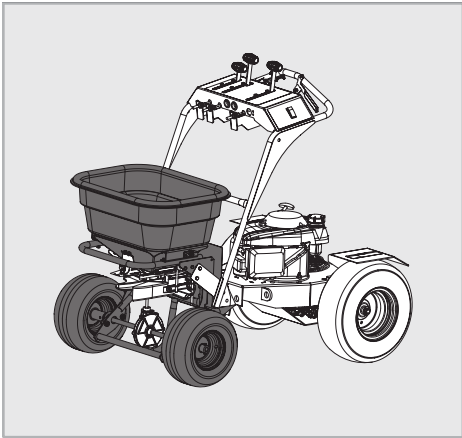

## SECTION 1

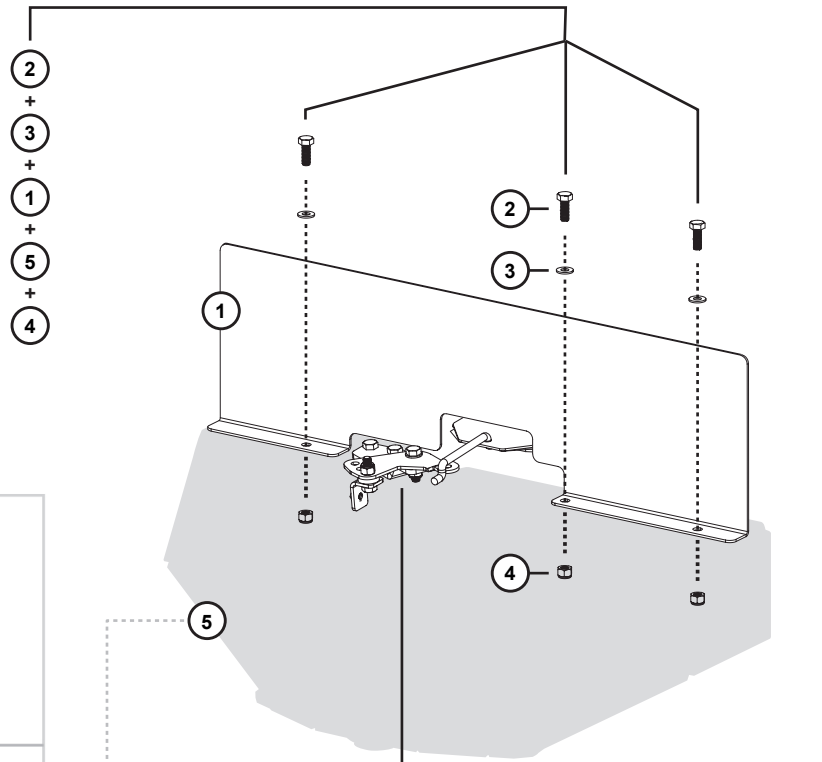

### FRONT FRAME

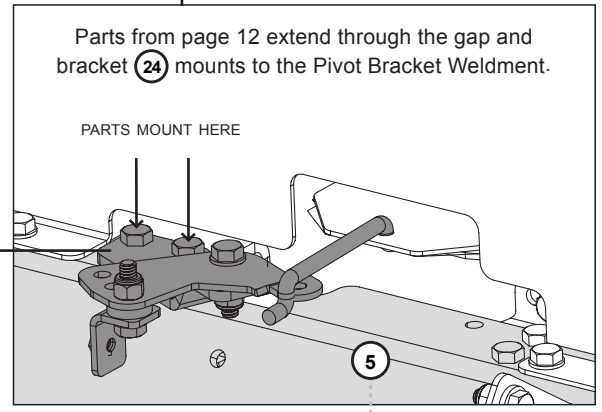
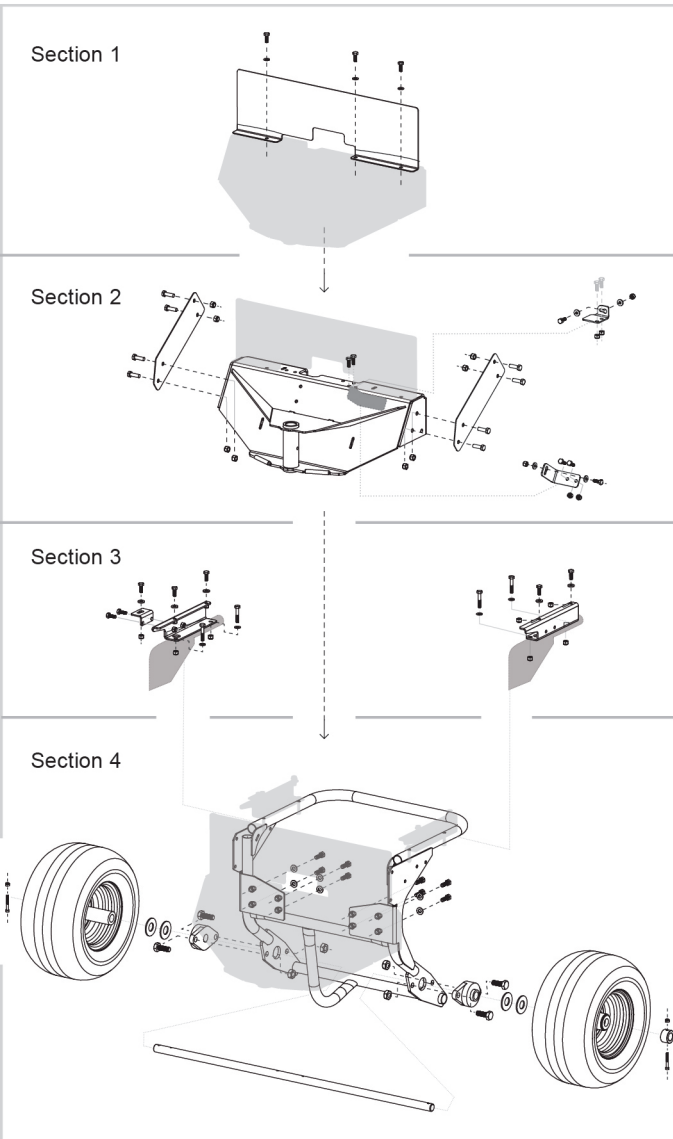

Item #	Name & Part No.	Qty.
1	<b>Shield</b>	1
	1009014	
2	<b>Bolt, Hex Head SS 1/4 x 3/4</b>	22
	1006084	
3	<b>Washer, SS 1/4"</b>	17
	1001351	
4	<b>Nut, Nylon Lock SS 1/4-20</b>	37
	1005198	



# FRONT FRAME & HOPPER ASSEMBLY

## SECTION 2

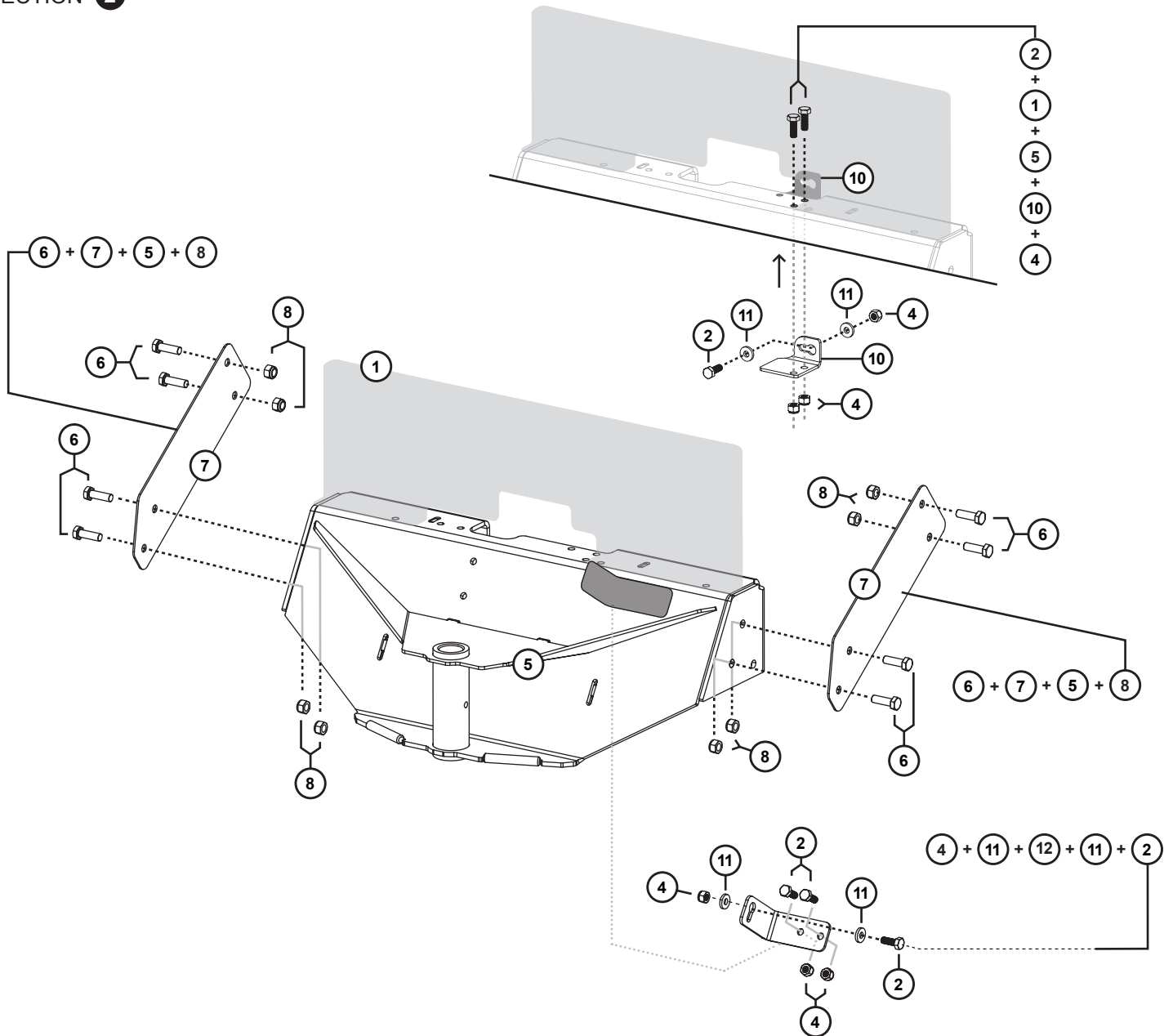

Item #	Name & Part No.	Qty.
5	<b>Weldment, Pivot Bracket</b> 1008895	1
6	<b>Bolt, Hex Head 5/16 x 1</b> 2M1016P	12
7	<b>Bracket, Ship</b> 1009019-10	2
8	<b>Nut, Nylon Lock 5/16 - 18</b> B-4786	21

Item #	Name & Part No.	Qty.
9	<b>Bolt, Hex Head SS 1/4 x 3/4</b> 1006084	22
10	<b>Bracket, Accuway Cable</b> 1009012	1
11	<b>Washer, Nylon</b> 1001554	16
12	<b>Bracket, Gate Cable</b> 1009007	1

# FRONT FRAME & HOPPER ASSEMBLY

SECTION **3**

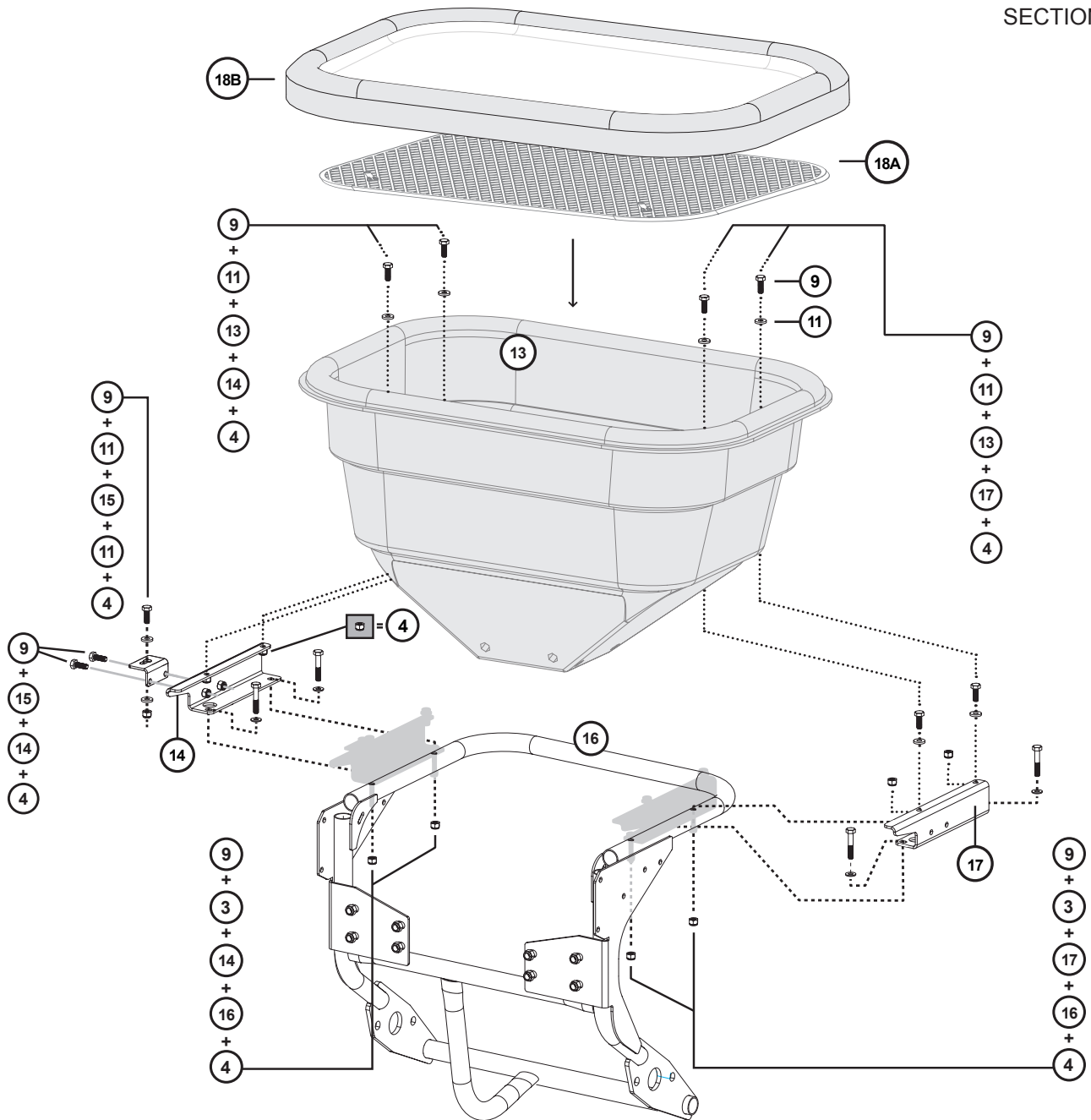

Item #	Name & Part No.	Qty.
13	<b>Drilled Hopper Assembly</b>	1
	1008732	
14	<b>Bracket, Hopper Left</b>	1
	1009003-LH	
15	<b>Bracket, Deflector Cable</b>	1
	1009010	
16	<b>Front Frame</b>	1
	1016743	

Item #	Name & Part No.	Qty.
17	<b>Bracket, Hopper Right</b>	1
	1009003-RH	
18A	<b>Screen</b>	1
	1008720	
18B	<b>Hopper Cover</b>	1
	1006262	

# FRONT FRAME & HOPPER ASSEMBLY

## SECTION 4

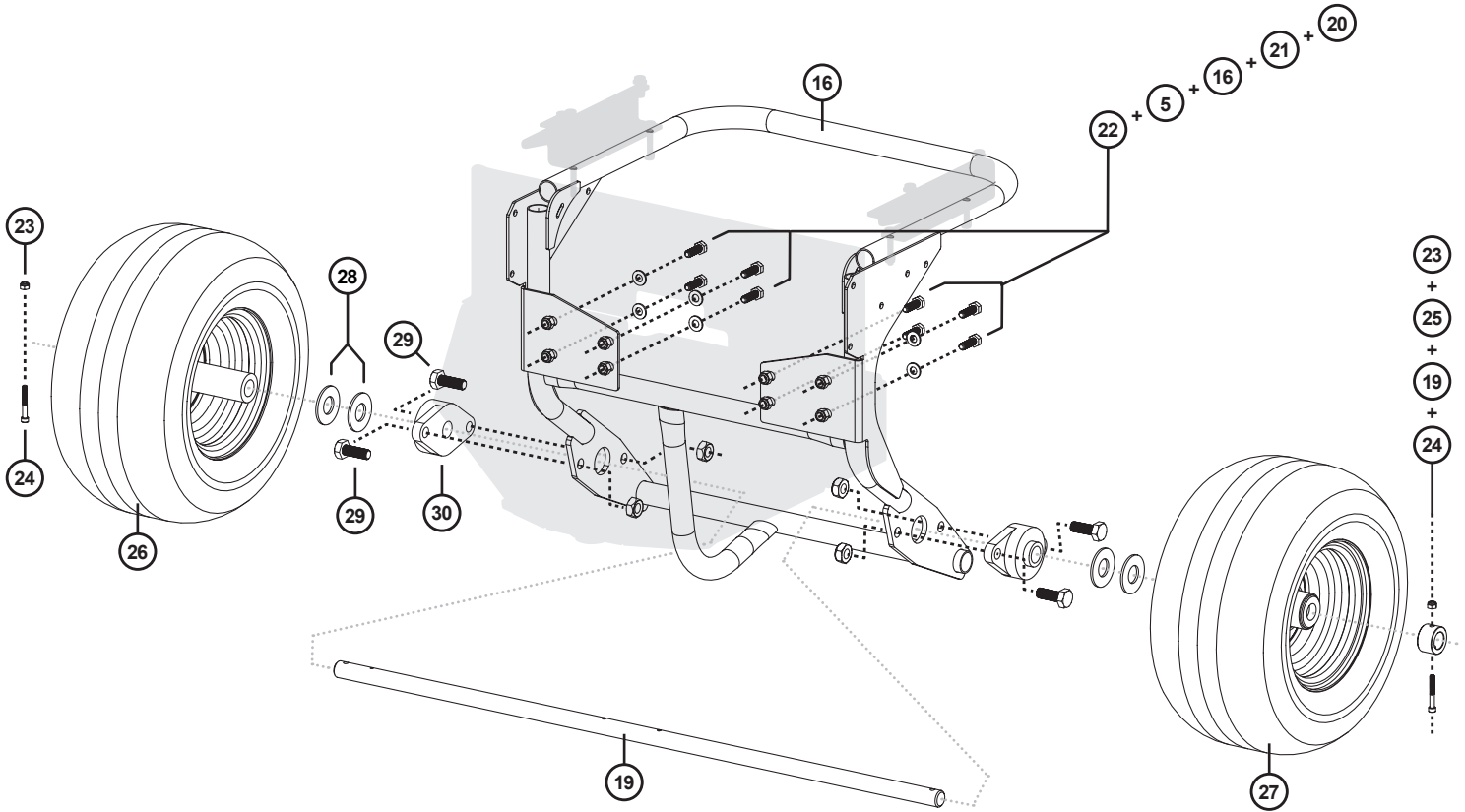

19 goes through:  
 26 + 28 + 30 + 17 + 30 + 28 + 27 + 25

Item #	Name & Part No.	Qty.
19	<b>Front Axel</b> 1016784	1
20	<b>Bolt, Hex</b> 5/16-18x1 SS316 1008811	8
21	<b>Washer, Flat</b> SS-5/16" 45M1111SS	8
22	<b>Nut, Nylon Lock</b> 5/16-18 1001315	8
23	<b>Nut, Nylon Lock</b> #10-24 SS 1001308	12
24	<b>Bolt, Socket</b> 10-24 x 1.5 1008869	2
25	<b>Collar, Shaft</b> 1008822-01	1

Item #	Name & Part No.	Qty.
26	<b>Wheel Assembly Drive</b> 1008816	1
27	<b>Wheel Assembly Idle</b> 1008818	1
28	<b>Washer, Flat</b> 3/4 SS18-8 1008812	4
29	<b>Bolt, Hex Head</b> 7/16 x 1-1/4 2M1420P	4
30	<b>Ball Bearings</b> 1016783	2
31	<b>Nut, Hex Head</b> 7/16-14 B-1676P	4

# IMPELLER & SHUT-OFF PLATE ASSEMBLY

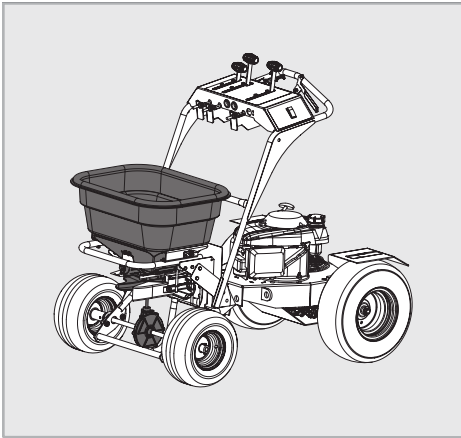

## IMPELLER & SHUT-OFF PLATE

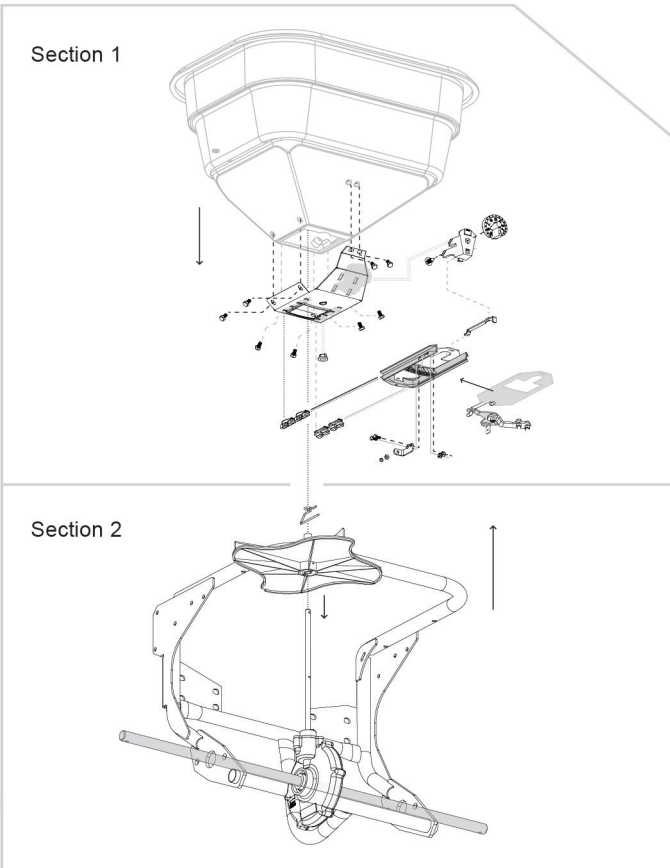

Item #	Name & Part No.	Qty.
1	<b>Hopper</b>	
	1008732	1
2	<b>Mulch Bottom Push</b>	
	1000766	1
3	<b>Hex Head Bolt, Stainless 1/4 x 1/2</b>	
	1004880	8
4	<b>Bottom Bearing, Hopper</b>	
	1000203	1
5	<b>Pine Tree Clip</b>	
	1000215	1
6	<b>Dial Mount</b>	
	1000211	1
7	<b>Dial, Milled</b>	
	1000733	1
8	<b>Rate Gate Linkage</b>	
	1000725	1
9	<b>Rate Gate</b>	
	1008244	1
10	<b>Accuway Diffuser</b>	
	1006147	1
11	<b>Guide Rate Gate / Accuway</b>	
	1001521	4
12	<b>Bolt, Stainless 10-32 x 1/2"</b>	
	1001264	2
13	<b>Nylon Lock Nut, Stainless #10-32</b>	
	1008748	2
14	<b>Nut #10-32 Stainless 18-8</b>	
	1009077	6
15	<b>Lock Washer, Stainless #10</b>	
	1007005	6
16	<b>Accuway Bracket</b>	
	1009011	1
17	<b>Cable Rod</b>	
	1008729	1
18	<b>Nylon Lock Nut, Stainless 1/4-20</b>	
	1005198	37
19	<b>Pivot Linkage</b>	
	1008707	1
20	<b>Nylon Flange Bushing</b>	
	1001533	8
21	<b>Cable Linkage</b>	
	1008708	4
22	<b>Washer, Stainless 1/4"</b>	
	1001351	17
23	<b>Hex Head Screw, Stainless 1/4-20 x 1"</b>	
	1001255	8

SECTION 1

# IMPELLER & SHUT-OFF PLATE ASSEMBLY

## SECTION 1

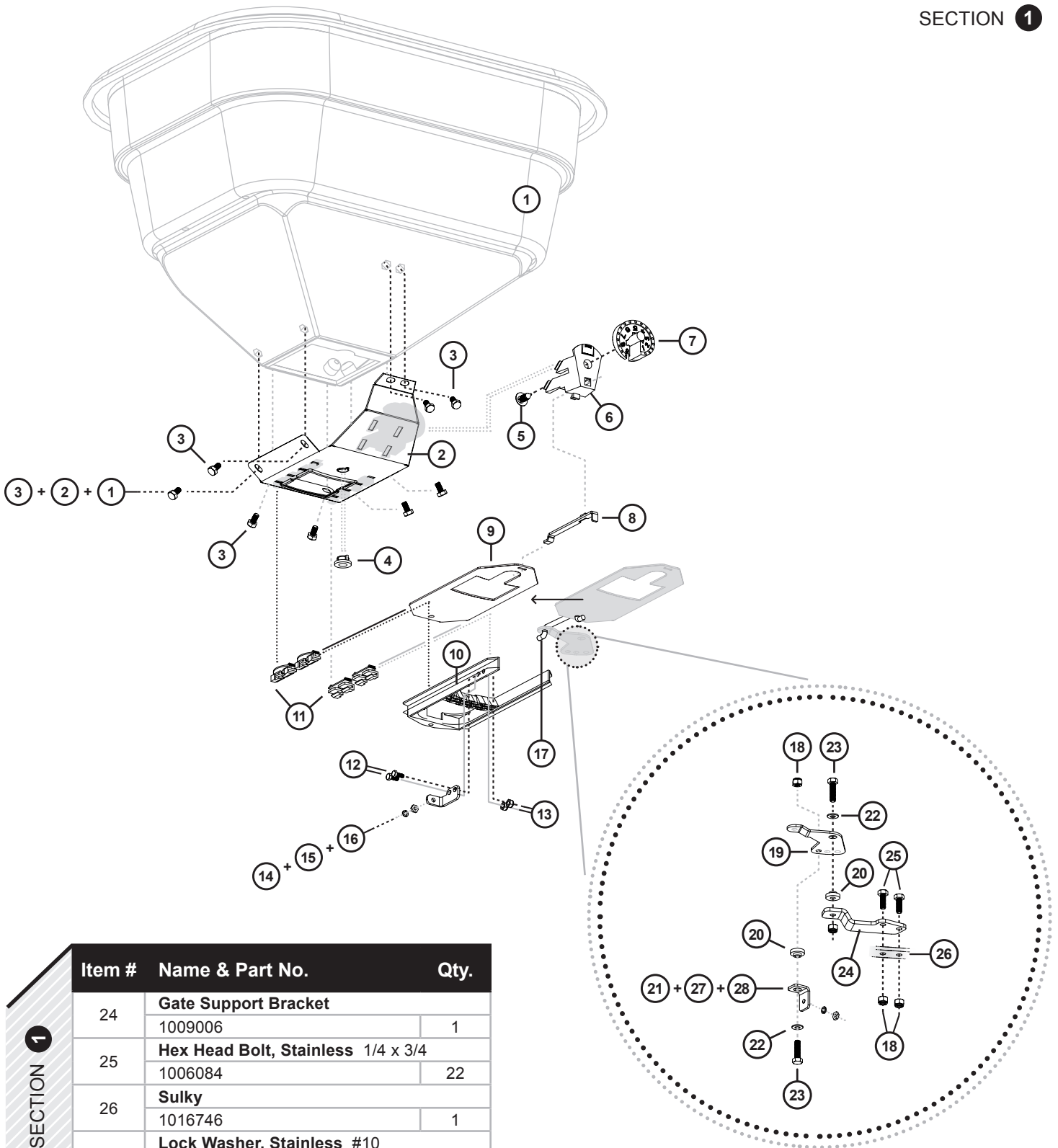

Item #	Name & Part No.	Qty.
24	<b>Gate Support Bracket</b>	1
	1009006	
25	<b>Hex Head Bolt, Stainless 1/4 x 3/4</b>	22
	1006084	
26	<b>Sulky</b>	1
	1016746	
27	<b>Lock Washer, Stainless #10</b>	6
	1007005	
28	<b>Nut, Stainless #10-31 18-8</b>	6
	1009077	

# IMPELLER & SHUT-OFF PLATE ASSEMBLY

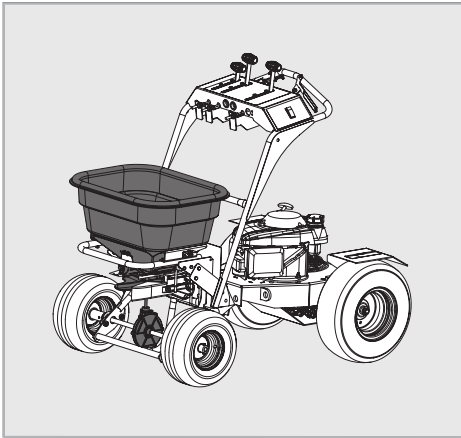

## SECTION 2

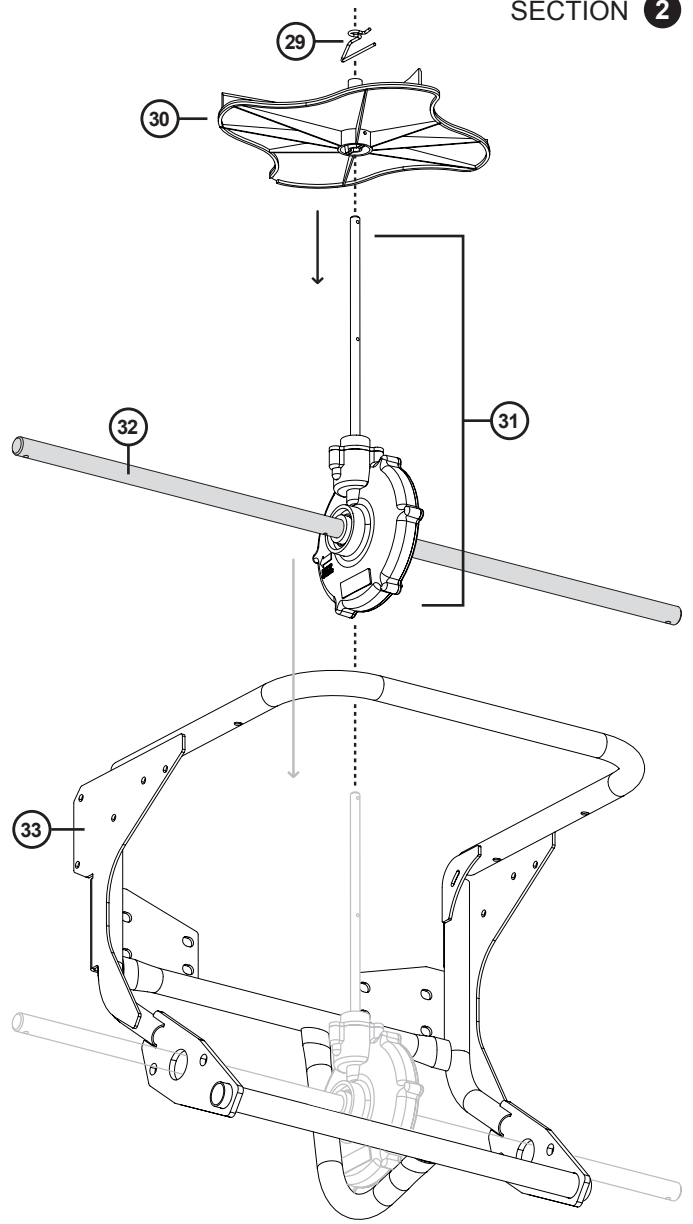

## IMPELLER & SHUT-OFF PLATE

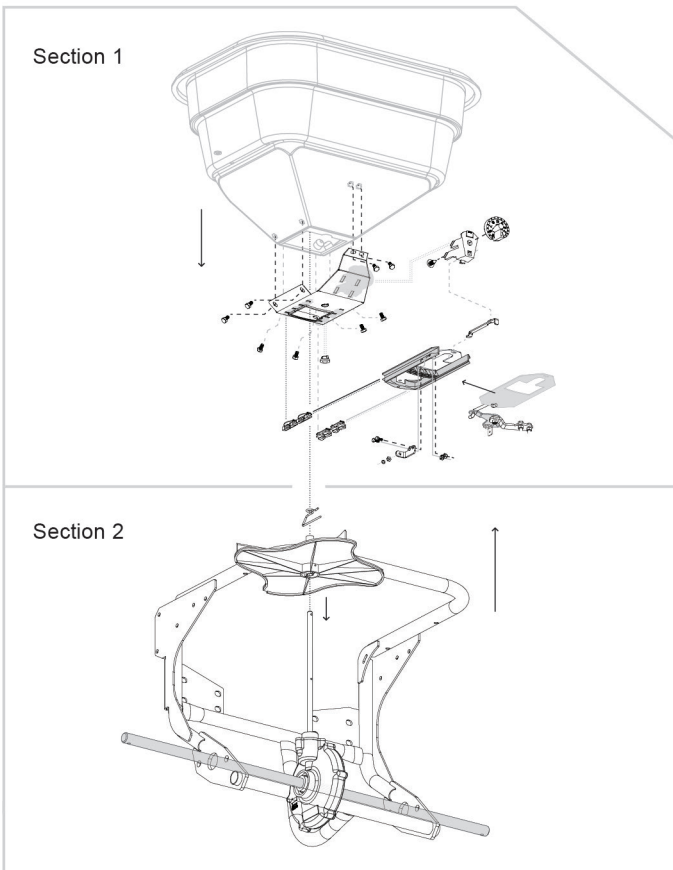

Item #	Name & Part No.	Qty.
29	<b>Spinner Clip</b>	1
	1001683	
30	<b>Drilled Spinner, Black</b>	1
	1000607	
31	<b>Transmission</b>	1
	1009004	
32	<b>Front Axel</b>	1
	1016784	
33	<b>Front Frame</b>	1
	1016743	

# SIDE DEFLECTOR ASSEMBLY



## SECTION 1

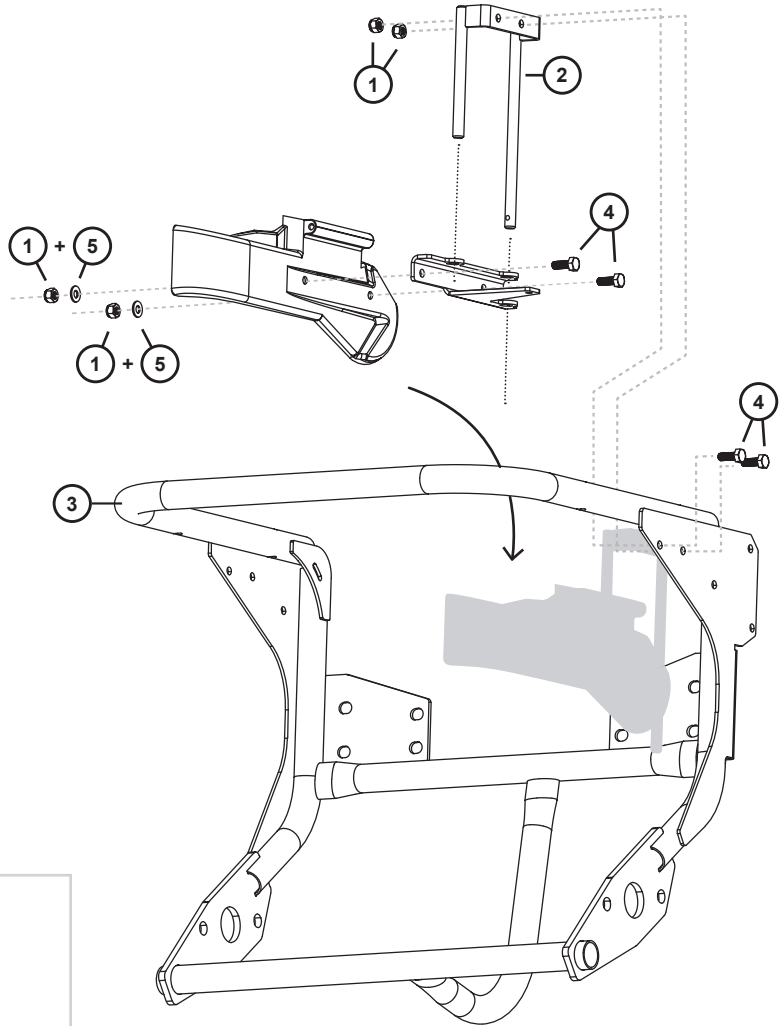

## SIDE DEFLECTOR

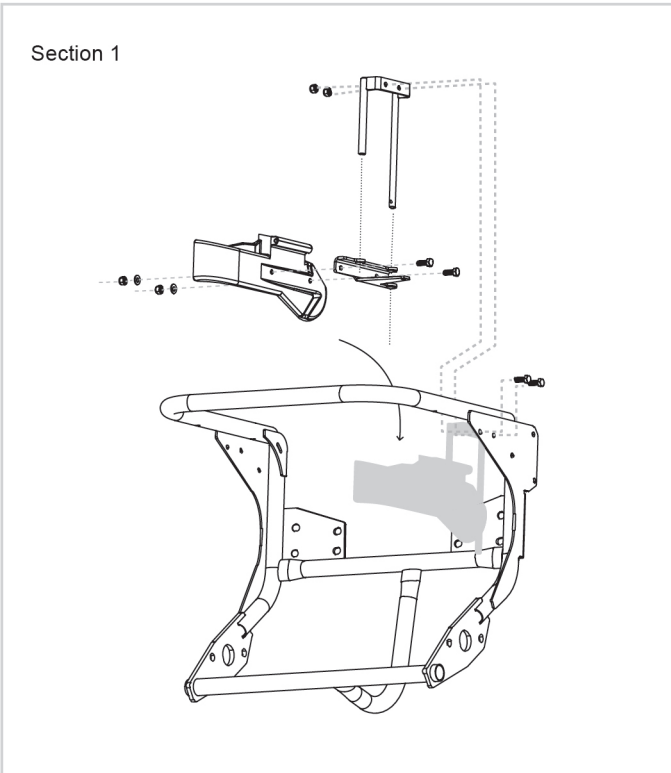

Item #	Name & Part No.	Qty.
1	<b>Nylon Lock Nut, Stainless 1/4-20</b> 1005198	37
2	<b>Weldment, Deflector Guide</b> 1009008	1
3	<b>Front Frame</b> 1016743	1
4	<b>Hex Head Bolt, Stainless 1/4 x 3/4</b> 1006084	22
5	<b>Washer, Stainless 1/4"</b> 1001351	17
6	<b>Deflector Shield, Side</b> 1000684	1
7	<b>Bracket, Deflector Side</b> 1009009	1

# CONTROL ASSEMBLY

## SECTION 1

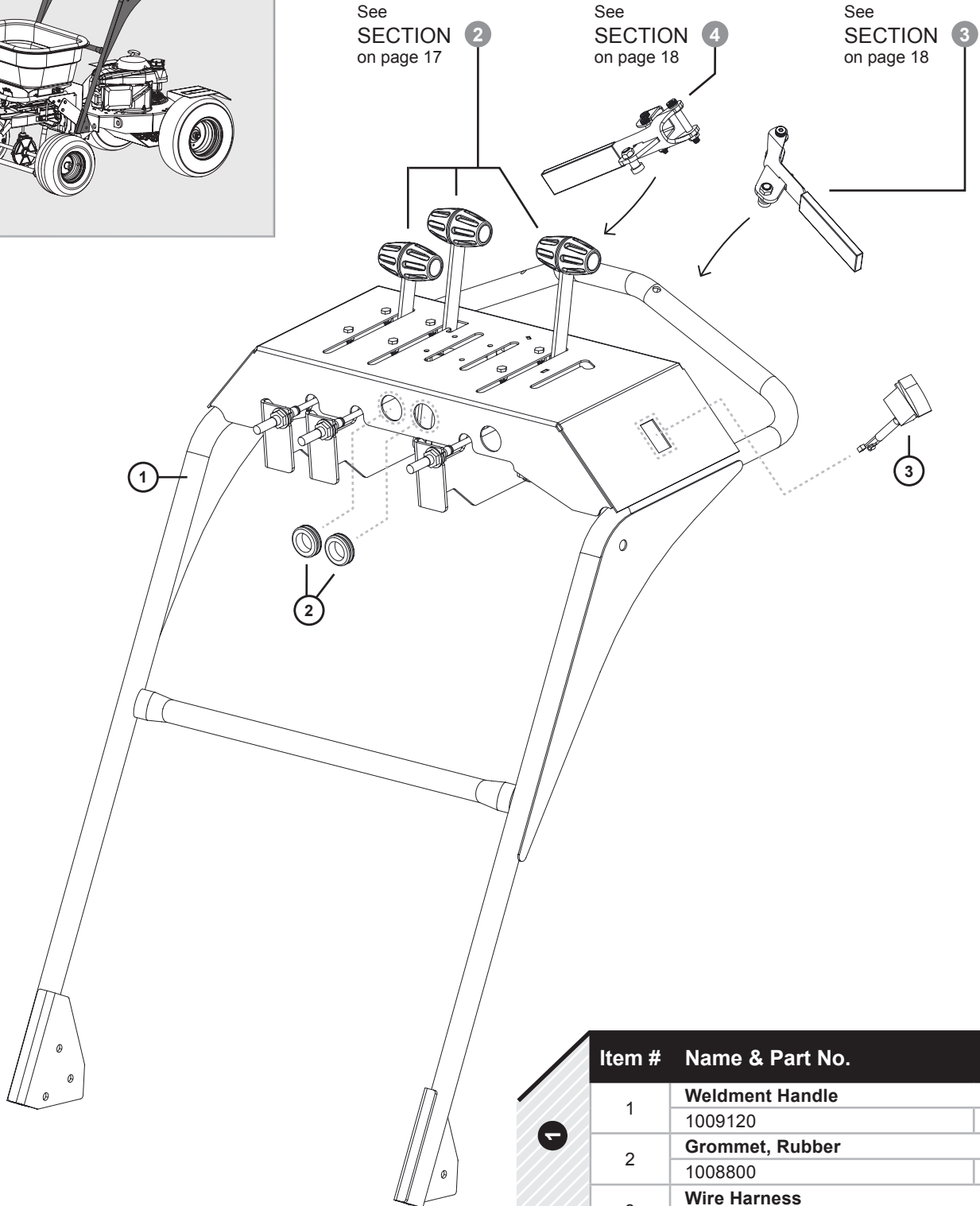

Item #	Name & Part No.	Qty.
1	<b>Weldment Handle</b>	
	1009120	1
2	<b>Grommet, Rubber</b>	
	1008800	6
3	<b>Wire Harness</b>	
	1017255	1



# CONTROL ASSEMBLY

## SECTION 2

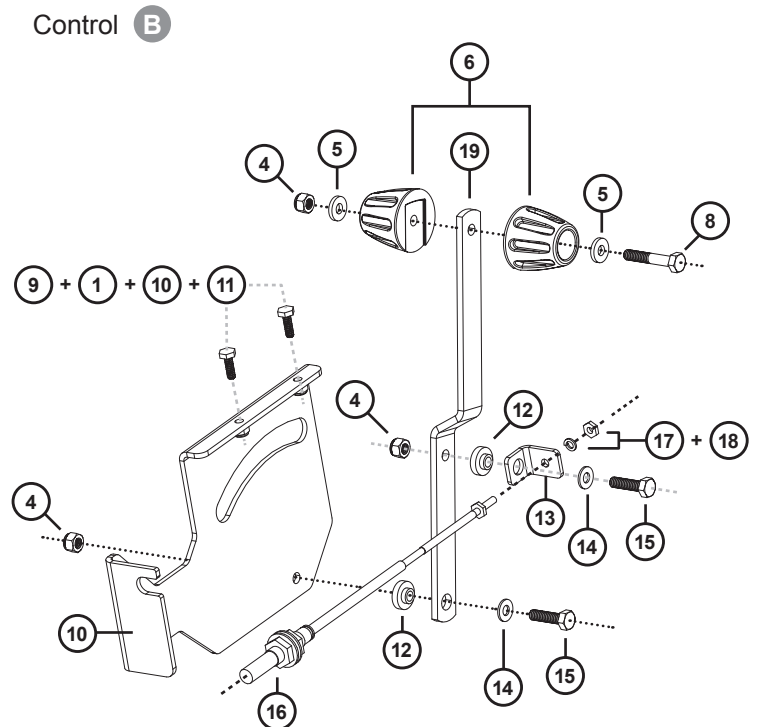
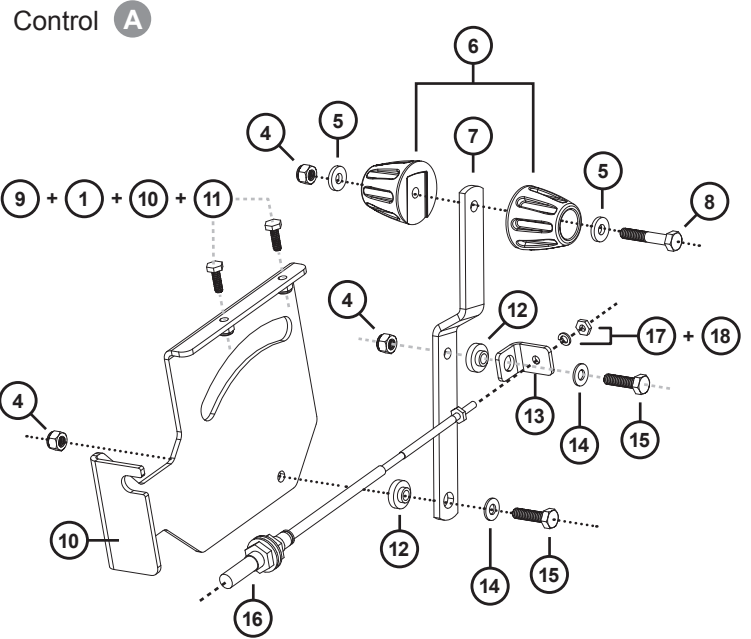
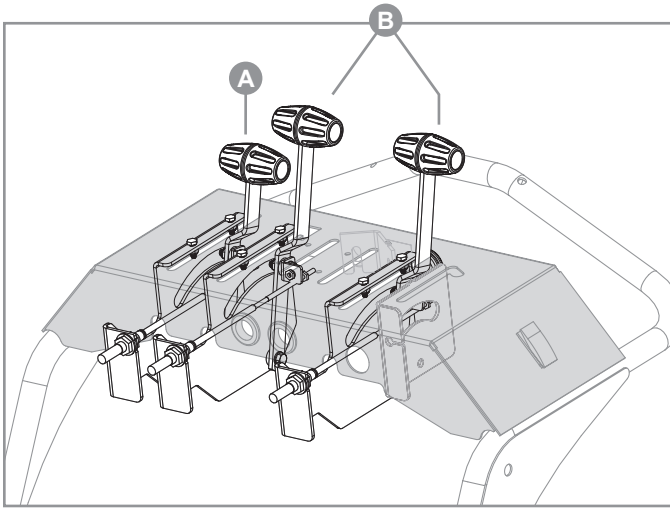

## SECTION 2

Item #	Name & Part No.	Qty.
4	Nylon Lock Nut, Stainless 1/4-20 1005198	37
5	Washer, Nylon 1001554	16
6	Knob, Handle 1007828	6
7	Short Lever 1009002-10	1
8	Hex Head Bolt, Stainless 1/4 x 1-1/2 1001262	7
9	Hex Head Bolt, Stainless #10 x 5/8 1001248	10
10	Bracket, Cable Handle 1009000-10	3
11	Nylon Lock Nut, Stainless #10-24 1001308	14
12	Bushing, Nylon Flange 1001533	8
13	Cable Linkage 1008708	4
14	Washer, Stainless 1/4" 1001351	17
15	Hex Head Screw, Stainless 1/4-20 x 1" 1001255	8
16	Cable 1009013	3
17	Lock Washer, Stainless #10 1007005	6
18	Nut, Stainless #10-32, 18-8 1009077	6
19	Long Lever 1009001-10	2

# CONTROL ASSEMBLY

SECTION 3

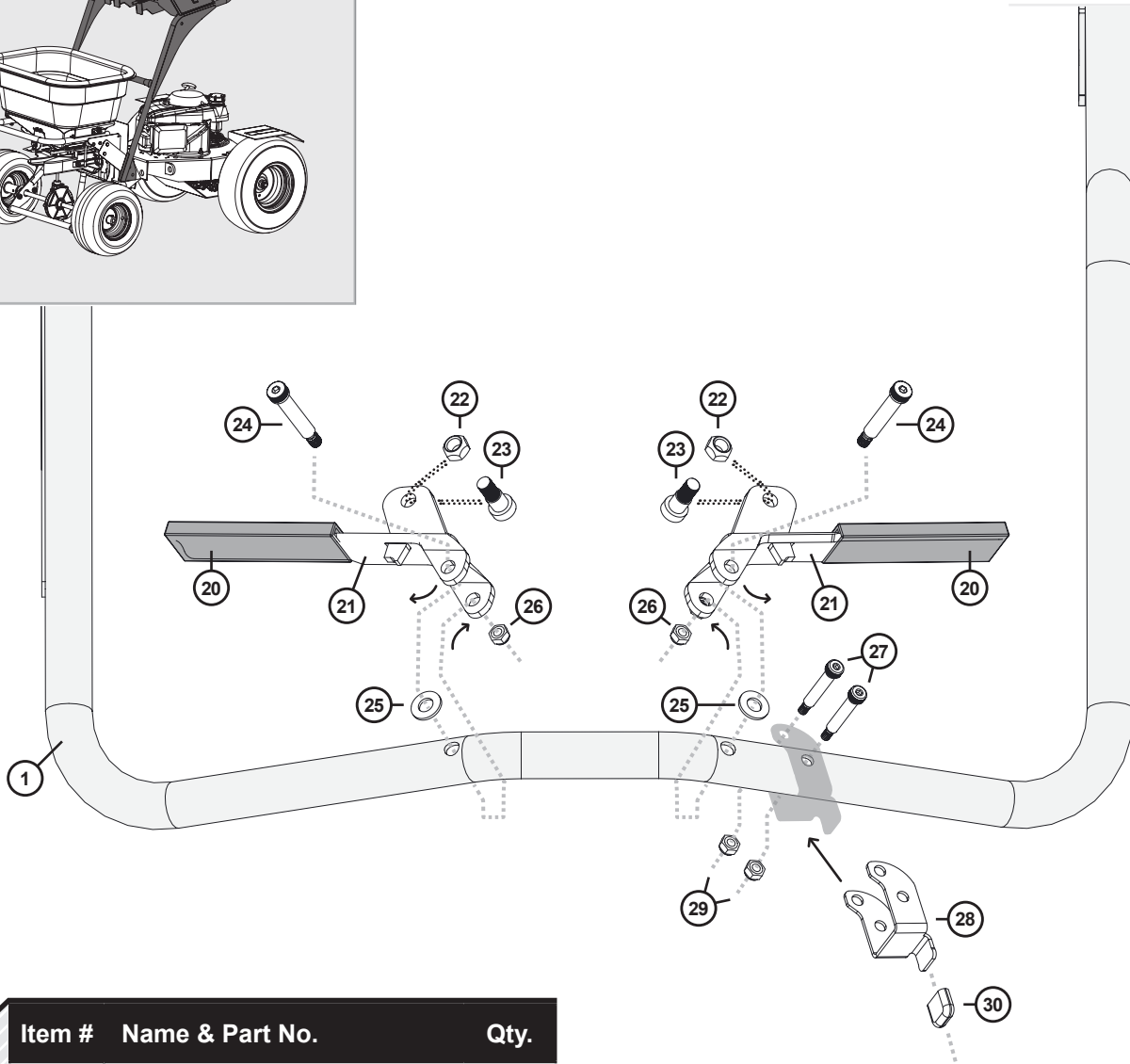

Item #	Name & Part No.	Qty.
20	<b>Grip, Rectangular</b> 1008831	2
21	<b>Lever Handle Weldment</b> 1009015-10	2
22	<b>Nut, Lock 5/16" - 18</b> B-1674P	3
23	<b>Shoulder Bolt 3/8 x 3/8 x 5/16-18</b> 1008833	2
24	<b>Shoulder Bolt 5/16 x 1.5 x 1/4-20</b> 1008835	2
25	<b>Flat Washer 5/16</b> 45M1111P	14
26	<b>Nut, Lock Center 1/4-20</b> 1008841	2

Item #	Name & Part No.	Qty.
27	<b>Shoulder Bolt 1/4 x 1.25 x 10-24</b> 1008834	2
28	<b>Speed Control Lever</b> 1008928-10	1
29	<b>Nylon Lock Nut, Stainless #10-24</b> 1001308	14
30	<b>Grip, PCV Yellow</b> 1008838	1

# FRAME DECAL ASSEMBLY

SECTION 1

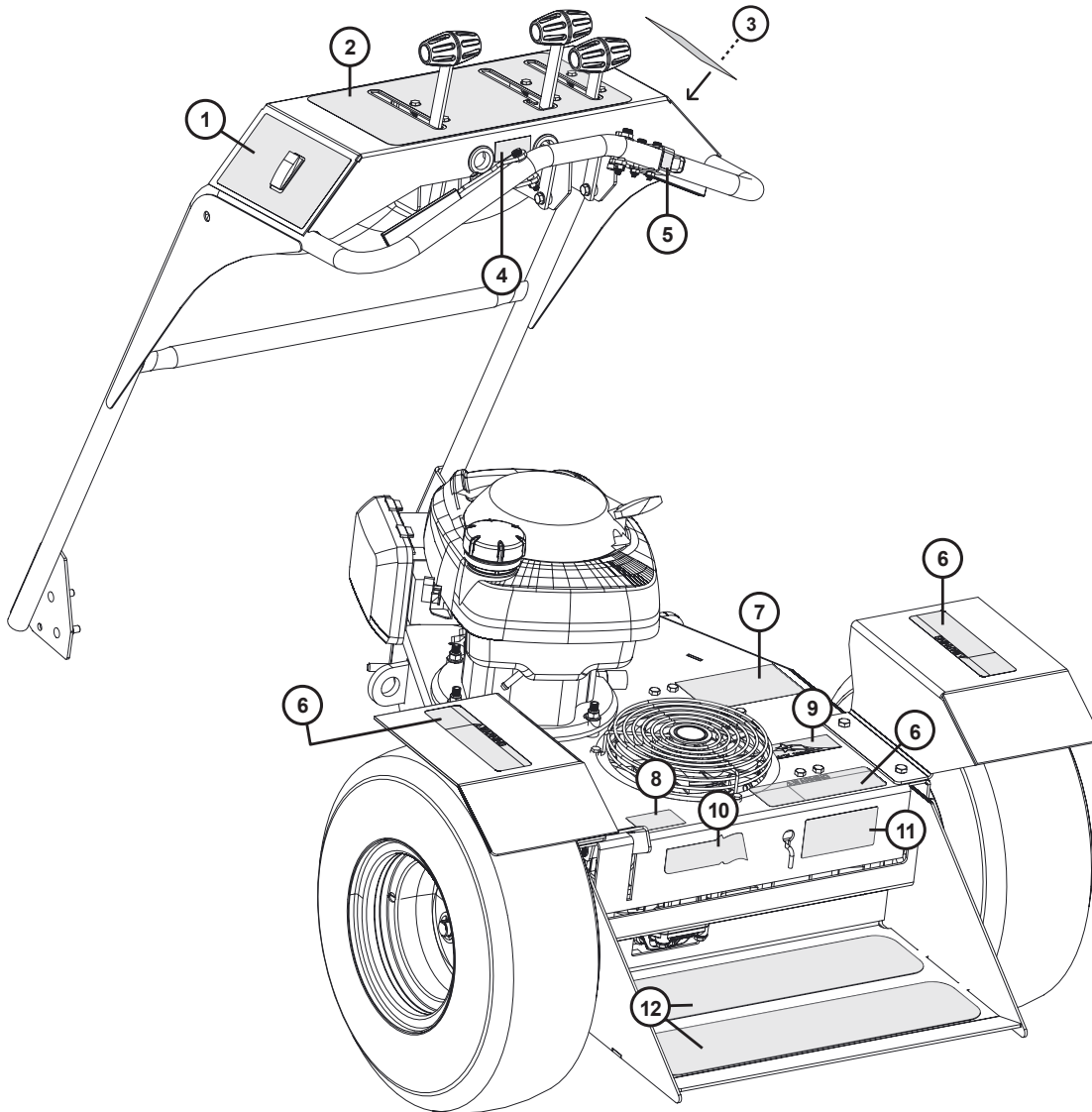

Item #	Name & Part No.	Qty.
1	<b>Start Label</b>	1
	1009121	
2	<b>Spreader Control Label</b>	1
	1009018	
3	<b>Calibration Label</b>	1
	1018621	
4	<b>Forward / Reverse Label</b>	1
	1008861	
5	<b>Speed Control Label</b>	1
	1008866	
6	<b>Warning Label</b>	3
	1008867	

Item #	Name & Part No.	Qty.
7	<b>Spyker Logo Decal</b>	1
	1008067	
8	<b>Parking Brake Label</b>	1
	1008864	
9	<b>USA Since 1839 Decal</b>	1
	1009165	
10	<b>USA Decal</b>	1
	1008862	
11	<b>Bypass Label</b>	1
	1017241	
12	<b>Grip Pad</b>	2
	1008807	



## **WARRANTY**

### **1 YEAR LIMITED WARRANTY**

This is warranted to the original purchaser only. Spyker will replace parts with defects in materials and workmanship, for a period of one year from the date of purchase.

For Spyker Spreaders—a Brinly-Hardy Company, products employing metal gear systems, pinion and bevel, these metal gears, only, not inclusive of any other parts or materials, are warranted for the life of the spreader, not to be used for replacement or repair past original purchase.

Spyker Spreaders will not be liable for any loss, damage or expense including, but not limited to, consequential or incidental damages, arising from the operation, condition or use of the item. The sole and exclusive remedy against Spyker Spreaders being the replacement of the defective parts. This warranty gives you specific legal rights, and you may also have other rights which vary from state to state.

**This express warranty, which is applicable only to the original purchase, is in lieu of and excludes all other warranties, whether expressed or implied by operation of law or otherwise, including any warranty of merchantability or fitness for particular purpose.**

**SPYKER SPREADERS**  
Jeffersonville, IN 47130 USA  
Phone: 800.972.6130