

Shelf Management MERCHANDISING SOLUTIONS



kostklip[®]
LIFE AT THE SHELF EDGE

Toll-Free North America 1.800.661.5547

Kost Klip Manufacturing Ltd. | sales@kostklip.com | www.kostklip.com



The Shelf Management Merchandising Solutions brochure was created to provide you a library of easy-to-install shelf management tools. These merchandising solutions are designed to reduce operational costs, improve store appearance and help increase sales. Keep your products where it matters most – at the shelf edge, your most valuable real estate within the store! Contact kostklip® for custom sizes and configurations.

Advantages & Benefits

REDUCED COSTS

- by **lowering** replenishment purchases for unnecessary inventory
- by **minimizing** stocking labor – reduces customer product rearrangement
- by **simplification** – easy to install and maintain without additional fasteners or required tools

IMPROVED

- **customer experience** – clean, organized shelves that keep products facing forward
- **shelf facings and allocation** – better shelf stock management
- **inventory management** – easily accommodates varying inventory allocation required by product turnover speed

KwikPull System



The Yogurt Tender®

Reduce labor, enhance presentation and promote rotation with the Yogurt Tender. The Yogurt Tender combines the simplicity and effectiveness of manual pull systems with a superior puller design and nesting dividers that creates zero planogram (POG) disruption.

The Yogurt Tender is specifically designed to merchandise dairy products (e.g. yogurt cups & cottage cheese tubs), where the top of the container is wider than the bottom. Note that the top of the container in most cases will hang over the left side of the base. Adjust the width on the front and back fence evenly, so that the left edge of the Yogurt Tender base is slightly outside the bottom edge of the product container.

ZERO
POG DISRUPTION

25%
FASTER STOCKING*

70%
FASTER FRONTING*

FASTER
POG CHANGES
& RE-SETS



The Shelf Tender®

The Shelf Tender® provides the same labor-saving and merchandising benefits as the Yogurt Tender®. Recommended for use with high moving products, such as cat food cans – and just about anything else in can, jar or bottle to keep products forward faced.

FEATURES + BENEFITS

- Full length magnetic strip holds the Shelf Tender firmly in place and can be easily repositioned
- Rear back clip slips over the shelf edge to provide extra staying power
- Optional extension paddle for larger or stacked items
- Easily add or remove individual Shelf Tender units as your planogram changes
- Made from durable clear PVC with UV inhibitors, the front fence clearly shows off your retail products
- Integrated front puller will never be misplaced and easily retracts out of the way
- Ideal for stacked products that are non-compatible with regular pusher systems
- No springs to break or tensions to worry about, Shelf Tender works with all product weights

ClearTrack™ Shelf Management System (SMSS)

Use kostklip's ClearTrack™ shelf management system to keep your product where it matters most – at the shelf edge! Our clear PVC, high quality modular system can be configured in a variety of sizes to meet your product facing requirements. Pushers and dividers are supplied, based on the number of product facings. ClearTrack™ can help improve sales and loss prevention. Hands-free product facing reduces labor costs and maximizes shelf appeal and profits.

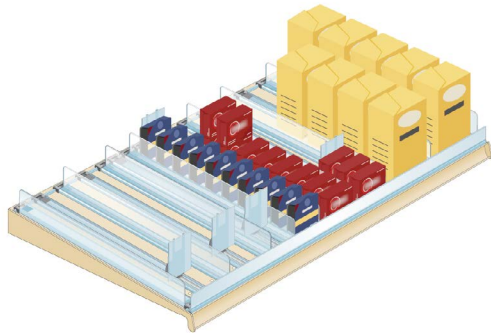

Fully adjustable tracks and dividers can accommodate a wide variety of product shapes and sizes

FEATURES:

- Ships pre-assembled with magnetic tape for fast box-to-shelf installation
- ClearTrack™ systems come complete with 15 facings, additional facings can be added
- Standard system is 48" wide and available in 12", 14", or 16" depths (all sizes noted are nominal)
- » Highly customizable: Order from our standard sizes, or contact us for more information on custom sizes

KwikLoad™ System

The KwikLoad™ System provides a quick and easy front-facing merchandising solution. A variety of front fence options allow you to display various sizes to meet your product facing requirements.

The KwikLoad™ System can be mounted on most standard store shelves or directly to the uprights using a crossbar mount kit.

Specific KwikLoads have been designed specifically for upright flat items including: packaged salads, bagged cheese, brick cheese, pasta, hot dogs, packaged deli meats, chocolate bars and drink crystals.



FEATURES:

- Slide out mechanism with locking paddle allows for easy one-handed stock loading and rotation
- Mounting options include standard crossbar and pegboard
- Standard systems are available in 14", 16", 18", 20", or 22" tracks
- Available in different sizes to accommodate a variety of products
- Durable heavy-duty construction ensures reliability, even in freezers



Light Duty Pusher Kit

The Light Duty Pusher Kit for Freezers is a simple and effective solution for shelf merchandising. They are made from high-impact styrene, maintenance free and compatible with most common flat shelving systems.

Contact us for custom sizes and colors.



FEATURES:

- Includes slide and lock mechanism for unlimited layout adjustability that adapts to your product needs
- Standard kit is 4' wide (contact us for custom widths)
- Includes 18 pusher tracks
- Standard dividers are available in 10"D, 12"D, or 14"D (contact us about the adjustable divider options)
- Pusher tracks are available in 10"D & 18"D
- Front fence: 1.5"H, 2.25"H & 3"H
- Available in various spring weights



Adjustable Spring Loaded Pusher

The Adjustable Spring Loaded Pusher provides a quick and easy front-facing pusher merchandising system. They are made from practically unbreakable high-impact styrene, maintenance free and compatible with most common flat shelving systems.

The pusher systems are available in white, black and can be color matched with a custom order (minimum order requirements).

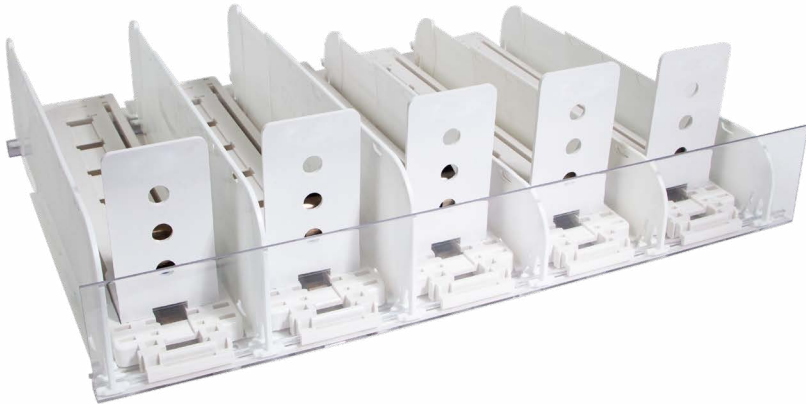

FEATURES:

- Includes slide and lock mechanism for unlimited layout adjustability that adapts to your product needs
- Standard kit is 4' wide (contact us for custom widths)
- Includes 6 – 8 pusher tracks
- Adjustable dividers are available in:
Height: 2" & 4"
Adjustable length: 12" – 16" & 16" – 20"
- Adjustable pusher track: 14" – 22" L
- Front fence: 1.5"H, 2.25"H & 3"H
- Available in various spring weights
- A bigger paddle can be attached
- Combine with push pins, foam tape or magnetic tape to fasten the pusher to the shelf

Medium to Heavy Duty Pusher Kit for Freezers

The Medium to Heavy Duty Pusher Kit for Freezers is a simple and effective solution for keep larger frozen items front-faced. They are made from high-impact styrene, maintenance free and compatible with most common flat shelving systems. Custom depths and widths can easily be created to fit all your shelving needs.

The pusher systems are available in white, black and can be color matched with a custom order (minimum order requirements).



FEATURES:

- Standard systems are available in 20", or 22" tracks
- Standard dividers are available:
Height: 4"
Depth: 16", 18", 20", or 22"
- Standard kit is 4' wide (contact us for custom widths)
- Includes 4 heavy duty pusher tracks
- Black coroplast base for added stability with 5 adhesive pads
- Durable heavy-duty construction ensures reliability, even in freezers
- An extra extrusion can be clipped under the dividers to create extra support for larger products like Pizza boxes
- Wider paddles can be attached to accommodate larger products

EasyRoller™ (GFRT)

The EasyRoller™ is the ideal gravity feed solution for automatically front facing products. Typically used with bottles and other flat based packaging, the EasyRoller™ keeps your shelves always presentable. Stock-outs can be spotted instantly, and re-stocking is a breeze.

The EasyRoller™ can easily be installed on existing shelving with the provided angle adapters or on custom angled shelving. Available in convenient 11.7" wide sections or custom widths for all types of shelves.

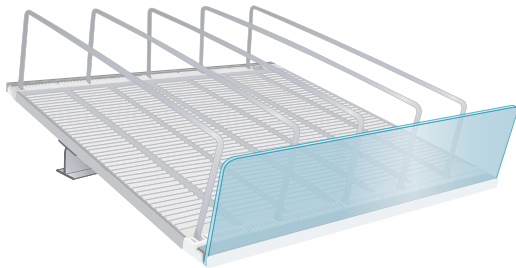

Made from highly durable aluminum with ABS construction

FEATURES:

- Gravity fed self-facing system
- Modular and available in a variety of sizes and configurations
- Various divider and installation options available
- Call us for more information and custom sizing

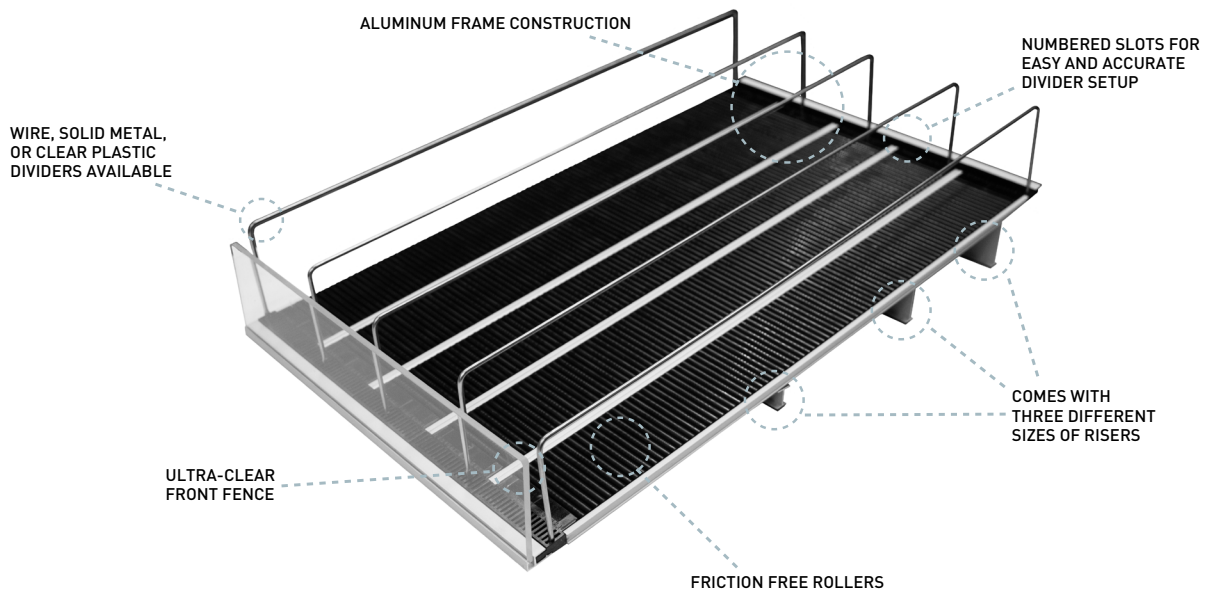

REDUCE LABOR COSTS

ENHANCE PRODUCT PRESENTATION

IMPROVE INVENTORY CONTROL

EASY INSTALLATION



NUMBERED DIVIDER INSERTS



EASY TO INSTALL WIRE DIVIDERS

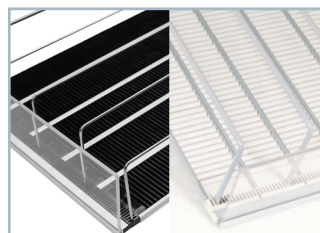

AVAILABLE IN BLACK OR BEIGE

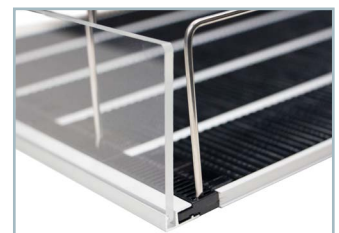

CLEAR FRONT FENCE AVAILABLE IN VARIETY OF SIZES

2-In-1 Magnetic Divider (TLD1, TLD3 & TLD5)

Our SKU reducing, innovative, tear-away dividers allow for time-saving and convenient installation and optimal product allocation. Easily convert a T-divider into an L-divider to fill product right to the ends of the shelf.

Enhance your customer's experience by maintaining clean and organized shelves throughout the store.

These dividers can be configured in a variety of sizes to meet your product facing and shelf depth requirements.

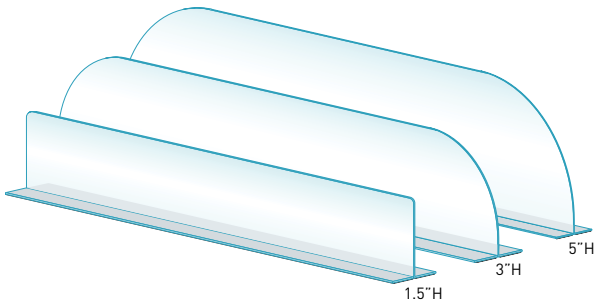

Made from extruded PVC for durability and high impact resistance

Two-in-one design allows for maximum flexibility, easily converts from a T-style to L-style in one product – no tools required!

FEATURES:

- Curved corners for safe and easy product access
- Bend the notch at the base back and forth to break off and convert to L-style
- Comes with strong magnetic tape
- Available in 1.5" H (TLD1), 3" H (TLD3) and 5" H (TLD5)



EASILY CONVERT FROM T-STYLE TO L-STYLE

Maximize shelf space and keep SKUs low by converting T-style divider to L-style.

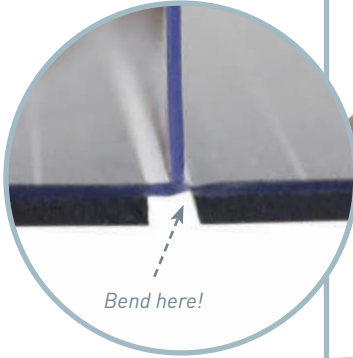

Simply bend back and forth at the notch to split apart. Only one side of the base detaches.



Inventory Saver Shelf Management (176D)

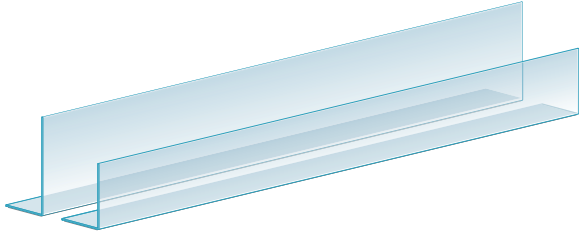

Better shelf stock management helps improve shelf facings and allocation alignments, reduces customer product re-arrangement by searching deep into shelves.

FEATURES:

- Rigid PVC plastic 'L' design provides a false back that helps minimize the amount of inventory sitting on a shelf
- Strong magnetic tape attachment ensures firm attachment to metal shelves
- Versatile design works for most shelf applications, easily accommodates varying inventory allocation required by product turnover speed

* Contact us for custom lengths

Shelf Divider System

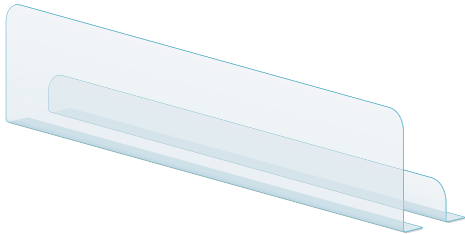

Shelf Divider (117D)

Made with high gloss, die cut PVC for durability and high impact resistance

FEATURES:

- Clear tape included
- » Available with magnetic tape or pushpins (sold separately)

* Contact us for custom lengths

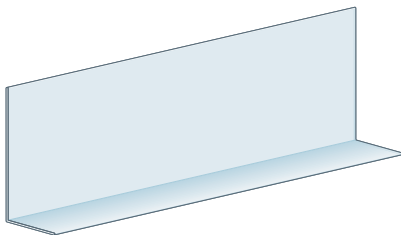

L-Bracket Display Builder (34LB)

Made from extruded PVC for durability and high impact resistance

Use to build merchandising displays

FEATURES:

- » Contact us for clear, magnetic and foam tape options

* Custom lengths available

PopLock™ T and L-Style Shelf Divider (246D & 247D)

Kostklip® has engineered a toolless shelf management system to keep your merchandise in line. The PopLock™ T & L-style Divider is an economical shelf divider system that has built-in pins to secure itself to metal shelves. If you need to reuse and relocate dividers, re-attach T & L-style dividers to the shelf with our X-Mas Tree Fasteners.

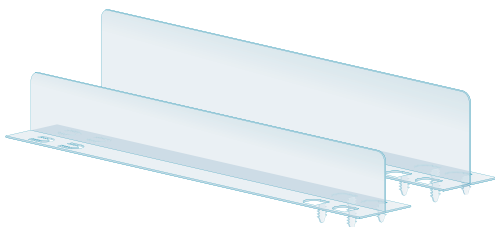

Built-in PopLock™ pins eliminate the need for adhesives or magnetic tape to attach to shelving

FEATURES:

- Relocate dividers by turning 180° and using fresh set of PopLock™ pins on other side
- Two-in-one design allows for maximum flexibility, easily converts from T-style to L-style divider in one product

* Custom lengths available

Wire Divider Systems

Kostklip's manufacturing capabilities include plastic, print and metal & wire products. Whether it be a wire fence, basket or custom design, kostklip® works with you to create the perfect solution for your merchandising needs. Choose from one of our in-stock products or call to have something made to order for your specific requirements.

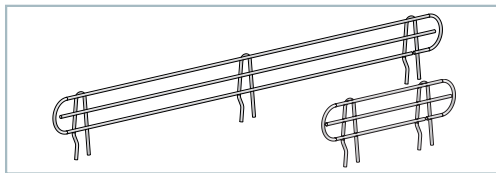
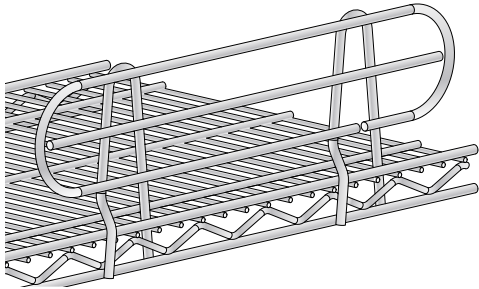

Wire Ledge for Metro® Shelf Management (WFMS)

Attaches to the front, back and sides of all Metro® style wire shelves

FEATURES:

- Easy to attach to shelves – no tools required
- Prevents products from falling off shelf

* Custom lengths and styles available
* Call for more details

CONTACT US FIND OUT MORE ABOUT
OUR WIRE FENCE OPTIONS

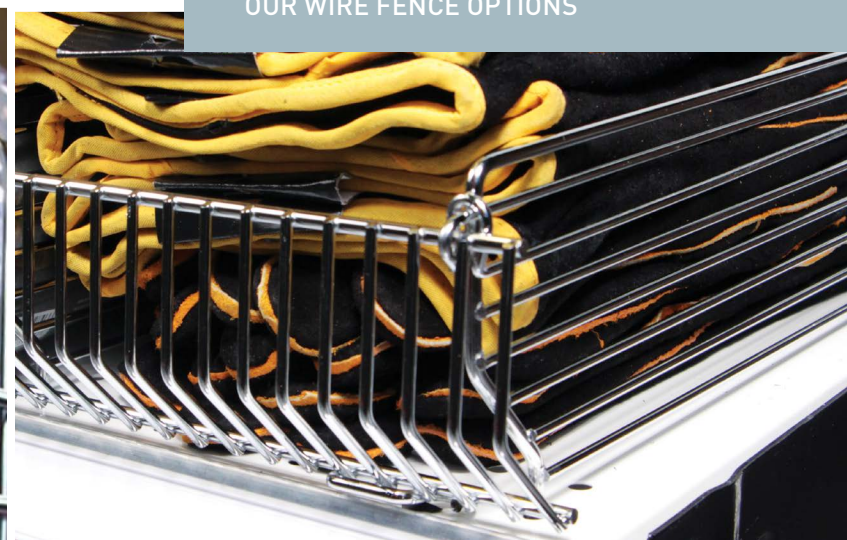

CONTACT US TODAY

Call us today to learn more about our Shelf Management System!



1.800.661.5547 | sales@kostklip.com | www.kostklip.com
119-1611 Broadway St, Port Coquitlam BC V3C 2M7

Shelf Management System Brochure_2023 | Printed in Canada

IT'S EASY TO ORDER

CHOOSE ONE OF THE FOLLOWING METHODS:



Call Toll-Free
North America wide
1.800.661.5547



Fax your purchase order to
1.877.468.0007



Visit our website,
log in & order online
www.kostklip.com



Email your purchase order to
sales@kostklip.com



Hours of Operation
7:30 am – 4:00 pm
Pacific Time

FOLLOW US ON



@kostklip



@kostklip



@lifeattheshelfedge



kostklip®



kostklip®



kostklipShelfEdge