

C-STORE

MERCHANDISING SOLUTIONS



kostklip[®]
LIFE AT THE SHELF EDGE

Toll-Free North America 1.800.661.5547

Kost Klip Manufacturing Ltd. | sales@kostklip.com | www.kostklip.com



TABLE OF CONTENTS

- Introduction Page 3
- Shelf Label Strips Page 4
- Shelf Management System Page 6
- Label Holders Page 10
- ShelfTalkers™ (Sign Sleeves & Protectors) Page 11
- Sign Clips & Grips Page 12
- Sign Holders Page 13
- Product Merchandisers Page 16
- Display Components Page 17
- ShelfTalkers™ (ChalkTalker™ Series & Signature Series) Page 18



PAGE 17 Suction Cup, Two Position Grip

PAGE 11 Sign Protector, One Fold ShelfTalker™

INTRODUCTION

Kostklip's C-Store Merchandising Brochure was created to provide you with a library of easy-to-install shelf organization and product labeling systems. Easily maximize shelf space to display a wide variety of SKUs in various sizes, even in your most complex application areas. All products shown can be customized to meet your required sizes.

Thank you for choosing kostklip® for your shelf edge and signage needs.



PerfPaper™ (107P)

This micro-perforated paper is specifically designed with a high moisture content to avoid drying out and curling after printing. It's also milled with a smooth surface that allows for better adhesion to toner. These qualities are especially beneficial to obtain the best clarity for printed bar codes as well as handling tickets during installation.



ClearVision® Series



ClearVision® is a non-adhesive shelf edge labeling system that features a clear, flexible window that holds, displays and protects plain paper price tickets. It's an integrated system that includes a variety of ticket moldings, printed plastic ShelfTalkers™ and sign holder accessories to lower operational costs and improve in-store communication. ClearVision® ticket moldings attach to every shelf edge to create a common fixture throughout the store for an effective and consistent in-store messaging program.

34WC

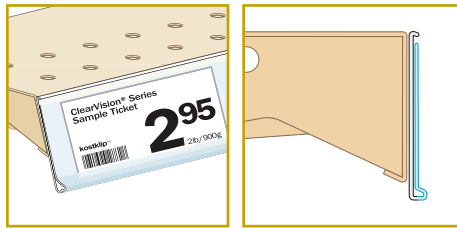

34RC

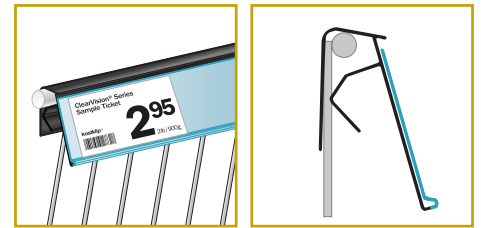

76WT

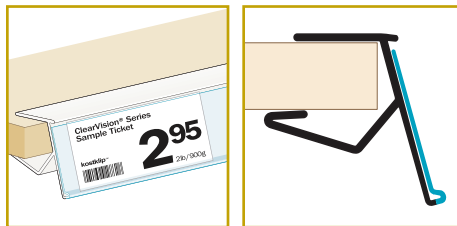

167T

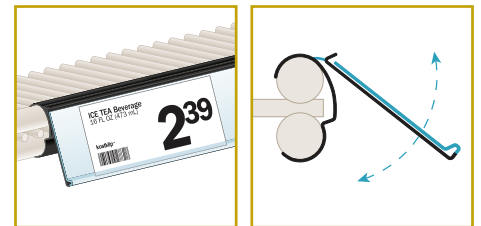

ClearGrip™ Series



ClearGrip™ is a non-adhesive shelf edge labeling system with a clear, flexible window and **built-in outer grip**. ShelfTalkers™ and cardstock signs can be quickly inserted anywhere along the shelf edge with the built-in flush grip. ClearGrip™ is an integrated system that includes ticket moldings, plain paper tickets and ShelfTalkers™ that creates an efficient and effective in-store signage program.

224T



216T

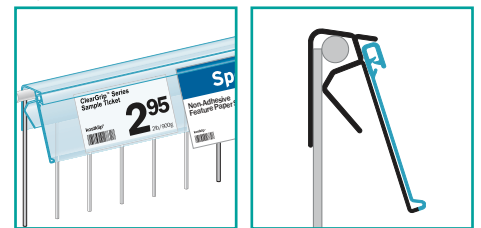



Flex Series



FlexChannel® is an innovative, one-size-fits-all price channel ticket molding that helps C-Stores reduce ticket molding SKUs when implementing a shelf edge labeling program in their store chain. It clips into most standard C-channel shelving.

* Contact us for custom colors and lengths

278T

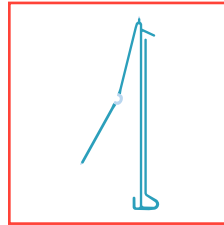

289T

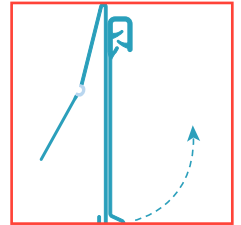

FlexKlip® Shelf Edge Adapters



FlexKlip® shelf edge adapters create a universal C-channel on various fixtures throughout the store, eliminating the need to purchase add-on PTMs from shelf manufacturers. FlexChannel® ticket molding eliminates the need for different back leg sizes, custom colors and lengths because it's a one-size-fits-all solution for all price channel applications.

Types of Fixtures

LARGE RATCHET

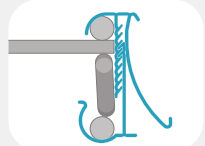
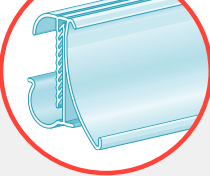

Metro® Wire Shelving

SMALL RATCHET

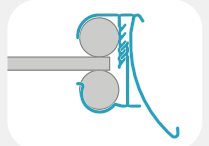
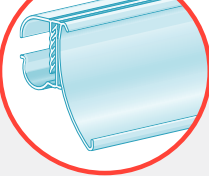

Double Wire Shelving

DUAL ANGLE

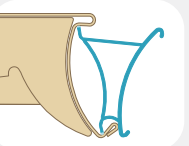
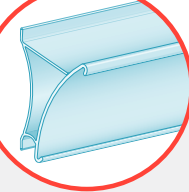

Lozier® C-Channel

WIRE FENCE

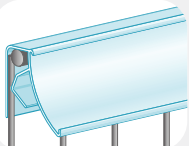
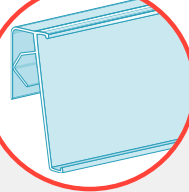

Wire Fence & Basket

GLASS & WIRE SHELF

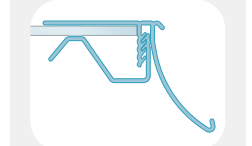
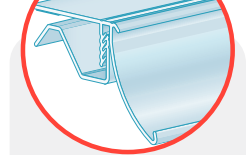

FlexKlip® Glass & Single Wire Adapter
(Up to 0.5" thick)

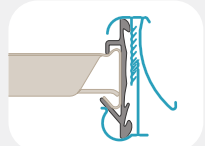

Hussmann® Aluminum PTM

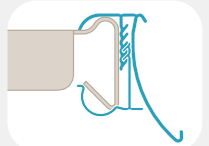

Hussmann® Bullnose

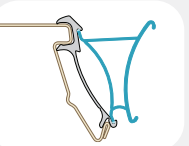

Hussmann® C-Channel PTM

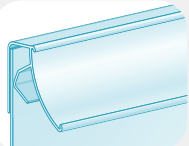

Vertical Glass

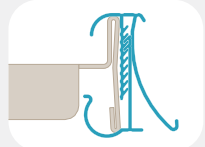

Bare Kysor/Warren®

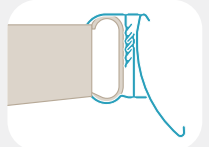

Zero Zone® Bullnose

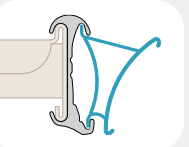

Hill-Phoenix® C-Channel PTM

SHELF MANAGEMENT SYSTEM

ClearTrack™ Shelf Management System

Use kostklip's ClearTrack™ shelf management system to keep your product where it matters most – at the shelf edge! Our clear PVC, high quality modular system can be configured in a variety of sizes to meet your product facing requirements. Pushers and dividers are supplied, based on the number of product facings. ClearTrack™ can help improve sales and loss prevention. Hands-free product facing reduces labor costs and maximizes shelf appeal and profits.

SMSS – ClearTrack™ Shelf Management System

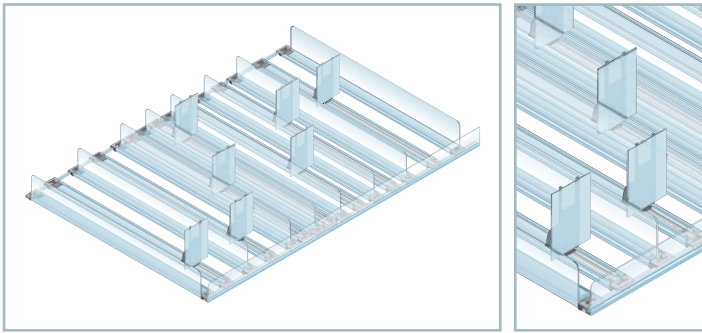

SMSD – Dividers

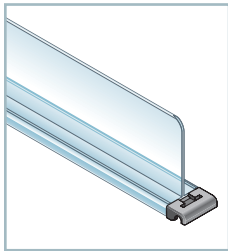

SMST – Pusher Assemblies

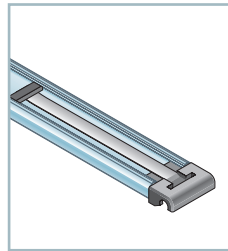

SMSP – Pusher Paddles

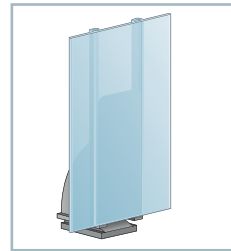

2-In-1 Magnetic Divider

Our SKU reducing, innovative, tear-away dividers allow for time-saving and convenient installation and optimal product allocation. Easily convert a T-divider into an L-divider to fill product right to the ends of the shelf.

Enhance your customer's experience by maintaining clean and organized shelves throughout the store. These dividers can be configured in a variety of sizes to meet your product facing and shelf depth requirements.

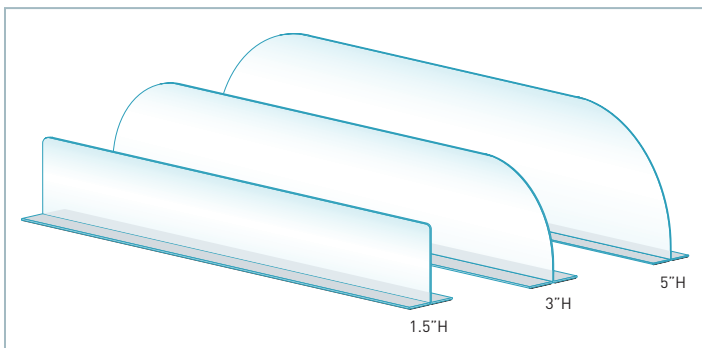



EasyRoller™ (GFRT)



The EasyRoller™ is the ideal gravity feed solution for automatically front facing products. Typically used with bottles, cans and other flat based packaging, the EasyRoller™ keeps your shelves always presentable. Stock-outs can be spotted instantly, and re-stocking is a breeze.

The EasyRoller™ can easily be installed on existing shelving with the provided angle adaptors or on custom angled shelving.

Available in convenient 11.7" wide sections or custom widths for all types of shelves.

REDUCE LABOUR COSTS

ENHANCE PRODUCT PRESENTATION

IMPROVE INVENTORY CONTROL

EASY INSTALLATION

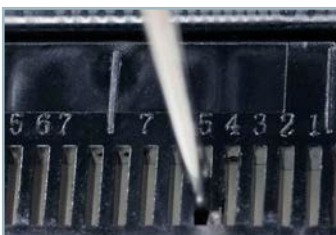

NUMBERED DIVIDER INSERTS



EASY TO INSTALL WIRE DIVIDERS



AVAILABLE IN BLACK OR BEIGE

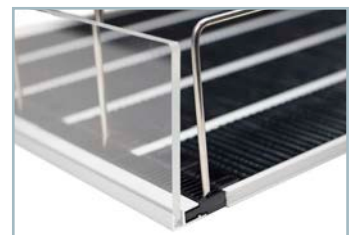

CLEAR FRONT FENCE AVAILABLE IN VARIETY OF SIZES

SHELF MANAGEMENT SYSTEM

KwikPull System

Cut labor, enhance presentation and promote rotation



The Yogurt Tender®

The Yogurt Tender® combines the simplicity and effectiveness of manual pull systems with a superior puller design and nesting dividers that creates zero planogram (POG) disruption.

SPECIFICATIONS

- Available lengths: **18", 20", 22", 24" & 28"**
- Divider height: 5" – custom heights available
- Merchandise lifted from shelf surface: 0.30"
- Adjustable width sizes:
2.621" width to 5.00" width
- Color: **Clear**

(Contact us for custom colors and lengths)

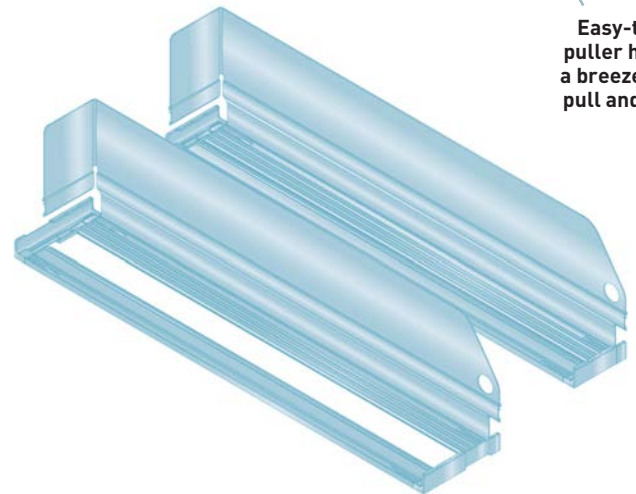

Easy-to-grasp puller handle is a breeze to find, pull and return.

ZERO
POG DISRUPTION

25%
FASTER STOCKING*

70%
FASTER FRONTING*

FASTER
POG CHANGES
& RE-SETS

The Shelf Tender®

The Shelf Tender® provides the same labor-saving and merchandising benefits as The Yogurt Tender®. Recommended for use with cat food cans, pasta sauce jars, single serve beer bottles – and just about anything else in a can, jar or bottle.

SPECIFICATIONS

- Available lengths: **18", 20" and 22"**
- **Custom lengths available**
- Merchandise lifted from shelf surface: 0.25"
- Three width sizes:
Small — 2 1/8" width
Medium — 2 3/4" width
Large — 3 1/2" width
- Color: **Clear**



SHELF MANAGEMENT SYSTEM

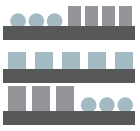

MERCHANDISING BENEFITS

- Rapid fronting lets you keep stock at shelf edge during peak shopping hours
- **Minimal or No facing loss;**
- **Dividers** prevent co-mingling of varieties



LABOR SAVINGS

- **25% faster stocking***
- **70% faster fronting***
- **Faster POG** changes and re-sets
- **Faster ordering**



ROTATION

- **Load-from-side** design lets you place new stock at rear
- No more products stranded at back of the shelf



OTHER BENEFITS

- **Category versatility** – fits most common products
- Impact resistant PVC withstands abuse
- **Made in North America**



EASY INSTALLATION

- **No tools** required
- Comes with a **magnetic tape** to hold it to the shelf

CONTACT US FOR MORE INFORMATION

* University of Pittsburgh study



Label Holders

Kostklip has a variety of label holders that easily attach to t-style or l-style wire or small plate scanning hooks. The clear, flexible window holds, displays and protects paper price tickets.

138L



141L

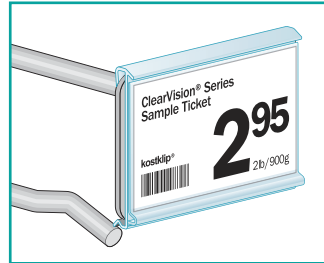

221T



SLAL



ShelfTalkers™

Sign Sleeves & Protectors

Made with high gloss PVC for durability and high impact resistance, which protects and extends the life of your paper sign. The sign holders are available in standard or custom sizes, so you can communicate your message in all areas of the store.



Wobbler and Dangler ShelfTalkers™

Made with high gloss PVC for durability and high impact resistance, which protects and extends the life of your paper sign. The free hanging design catches air movement to draw customer attention.

* Contact us for details on custom printing

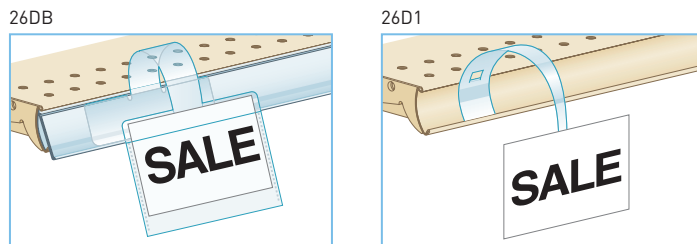

SnipAStrip™ Price Channel Label Protector, Roll

Made with high gloss PVC for durability and high impact resistance, protecting non-adhesive price label from damage, moisture, soiling and/or mishandling. Convenient and easy to apply.

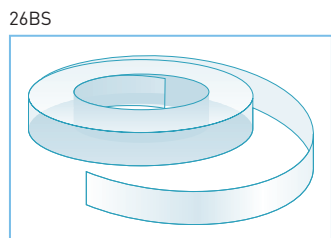

ShelfLife™ Colored Price Channel Insert, Unprinted

Made with smooth, thick 170lb medium paper. Color code departments or display corporate colors.

* Custom colors, lengths and printing available with minimum order



Sign Clips & Grips

Sign grips, sign clips, wire sign holders, flush and right angle.



ClearVision® and ClearGrip™ Sign Grip with Hinge

Kostklip's sign clips and grips can seamlessly be integrated into your store with ClearVision® and ClearGrip™ ticket molding. The PowerGrip® holds sign up to 0.06" thick and will not fall out when it gets bumped. Hinge feature allows you to flip up sign to make it easier for restocking.

* Custom sizes available

237C

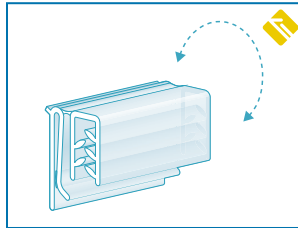

9554

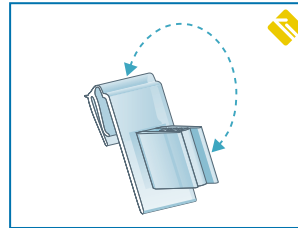

234C

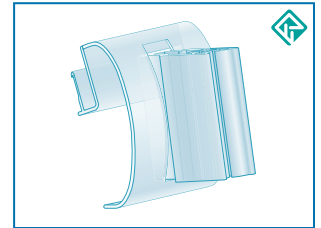

Fence & Basket Clip-On, Sign Grips

Kostklip's fence and basket sign grip can easily be integrated into your stores existing wire fences. These clips fits up to 0.375" diameter wire. The PowerGrip® holds sign up to 0.06" thick and will not fall out when it gets bumped.

* Custom sizes available

90FG

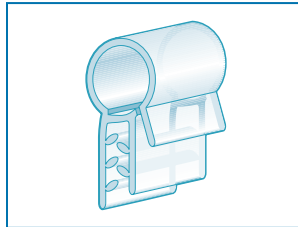

94FG

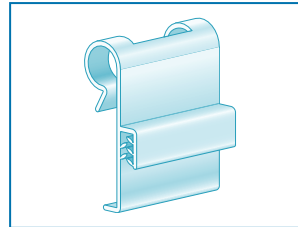

50WR

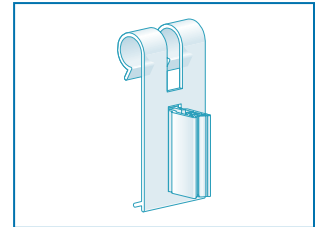

Sign Grips

Kostklip® provides a variety of sign grips that can be used in various areas of your store. Pallet display wedges easily slip in between boxes to display aisle specials or sale signs. Adhesive sign grips can be attached to any clean, flat surface to display flush or right angle signs.

* Contact us about custom sizes and tape options

183S

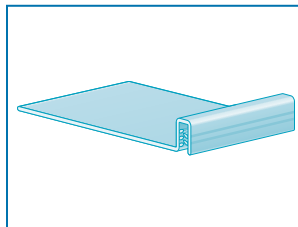

169S

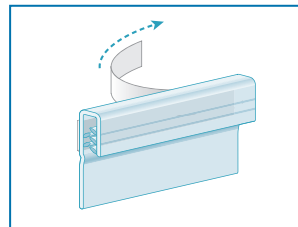

99TG

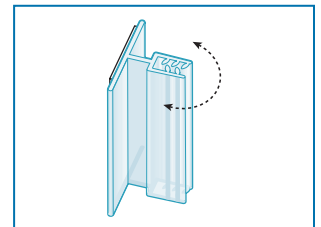

Sign Holders

L-Style and T-Style Sign Holders

Made from 0.060" PETG which has good optical properties, a brilliant surface and high impact resistance. Easily replace signs by sliding in and out from the side. Available in a wide range of sizes and in portrait or landscape formats. Call us for more details.

ESLS

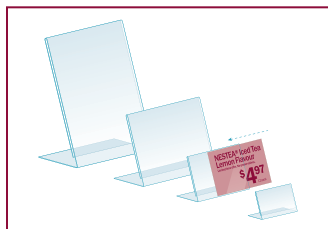

TLTS



Vinyl Pouch

Made from a soft flexible PVC. Sealed on three sides to protect and extend the life of your paper signs.

P001 & WRVP



SwivelKlip™

Use the plastic SwivelKlip™ to hang signage from a wire grid, basket or merchandising hook. Pinch clip swivels 360°.

CLIP

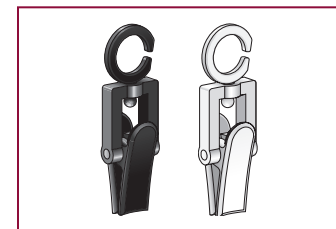

Three Side Sealed Sign Protector

Made from high gloss PVC for durability. Sealed on three sides to protect and extend the life of your paper signs.

* Custom us for alternate sizes and custom printing

SPRO



Multi-Use Counter Top, L-Style Clip

Supports sign protectors and card stock signs up to 0.187" in thickness.

84LS



Magnetic Base for PowerGrip® Channel

Combine MBSH magnetic base with MBRP PowerGrip® channel to display signs on gondola tops. Use the heavy duty sign holder on metal surfaces to display right angle signs. PowerGrip® holds material up to 0.25" in thickness.

MBSH + MBRP



MBSH

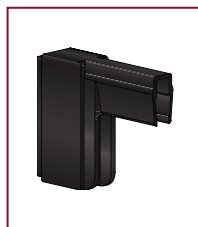

MBRP

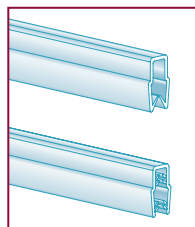

Top Mount, Right Angle, Aisle Sign Holders

Two-piece system attaches to shelf with pushpins. Interchange sign grip to hold material up to 0.25" in thickness. Can be used on most standard shelf hole patterns.

TMCH

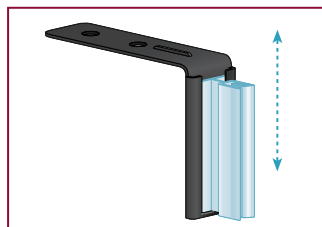

Aluminum Banner Hanger

Comes with removable eyelets and end caps for easy installation. The internal rubber grip secures signage up to 3/16" thick. Brushed finish.

ALBH

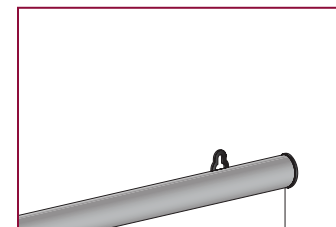

SIGN HOLDERS



TwistKlip™ Large Clip with Large Claw

Kostklip's TwistKlips™ are versatile sign holders for an endless number of applications. Our all-plastic TwistKlips™ are rust-proof and wash down so it can be used for open food and liquor tasting areas. The large claw is co-molded with a superior gripping layer that won't come off.. The clear top creates maximum readability to inform your customers about your merchandise. Combine the TwistKlip™ with one of our sign protectors to protect your paper signs from damage. Universal joint swivels in almost any direction.

124E



Counter Top Sign Holders

Kostklip's sign holders are perfect for store counter tops and shelves to display product information, tasting notes, or store specials. Use with kostklip's sign sleeves or protectors to protect your paper signs.

125E

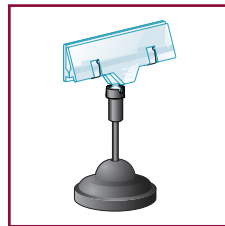

WSCH

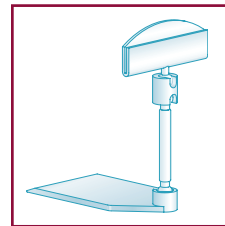

WSPC

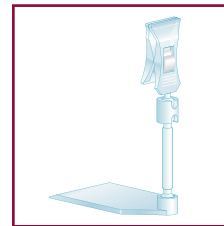

AKFB

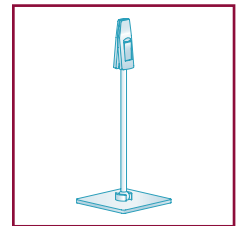

51K3



57G2

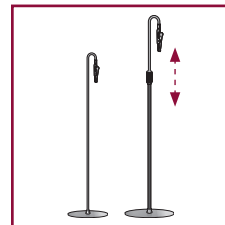

51S5



53S5



51S6

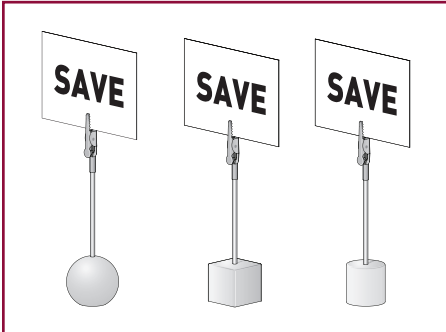

CHRS



SSH2



SSH3

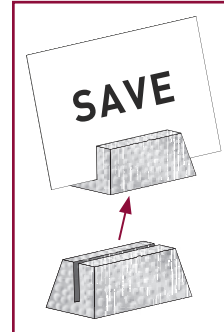

51S7

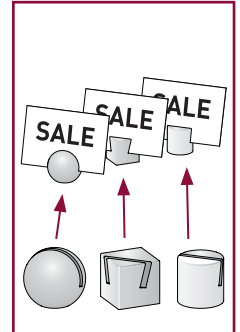

Telescopic Pallet Sign Holder

Use the sleek and adjustable pallet sign holder to display signage around your store. The large, low-profile base secures the sign holder under pallets, crates and other in-store displays. It has an adjustable height (48 – 82”H in 2” increments) and the arm can rotate in 90° positions.

TPSH

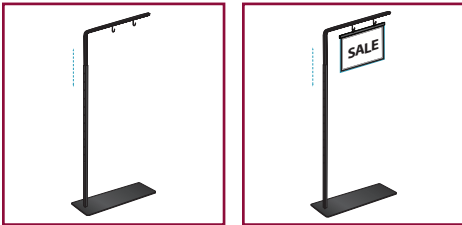

PowerGrip® Three Grip, Edge Stem, Adjustable Sign Holder

Powder coated steel plate with zinc tubing for a sleek look, displaying signs back to back, and up and/or down positions. The 4” PowerGrip® holds signs up to 0.06” thick. Adjustable height extends from 12” to 24”H. Available in edge or center stem.

54AW

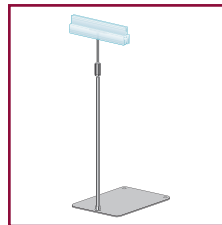

55AW



Indoor WalkTalker™ Sign Holder

Constructed from black powder coated steel for a sleek and professional look, it holds printed signs 22”W x 28”H. Includes hex key & hardware for easy assembly.

IWT1



IWT2



Outdoor WalkTalker™ Sign Holder

The Outdoor WalkTalker™ Sign Holder is wind and water resistant. The fillable base can be used with water or sand and spring loaded stem allows give in strong winds. Four sided aluminum snap frame enables quick and easy loading of signage.

* Also available in grey

SFSH



Product Merchandisers



Brochure Holder, Business Card Holder & Glass Door Merchandiser

Kostklip's crystal clear brochure & business card holders provide strong, durable, and affordable displays. Use CTBH and TBCH on countertops to hold & display product literature.

FFMS product merchandiser is ideal to use on refrigerator and cooler doors by placing suction cups on desired smooth, flat surface area.

CTBH

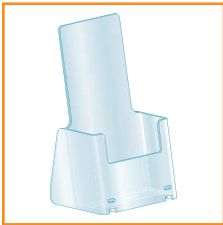

TBCH



FFMS

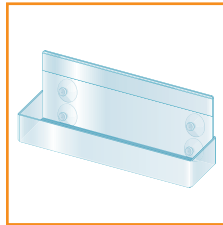

Display and Merchandise Strip Hangers

The strong hangers can each display two fully loaded merchandise strips, impulse buys. Card holder on top edge holds toppers and call-out signs to attract your customer's attention.

32MH

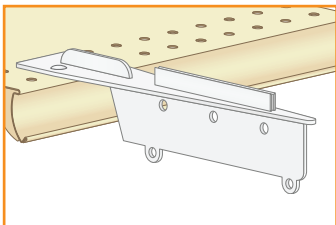

32SH

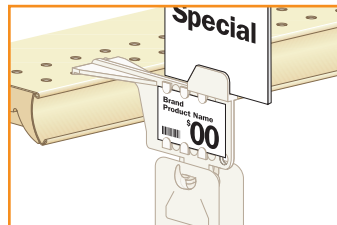

Merchandise Strip

Kostklip has a range of merchandise strips to accommodate various needs and product weights. 12 product tabs, available in light or heavy duty.

* Contact us for more information

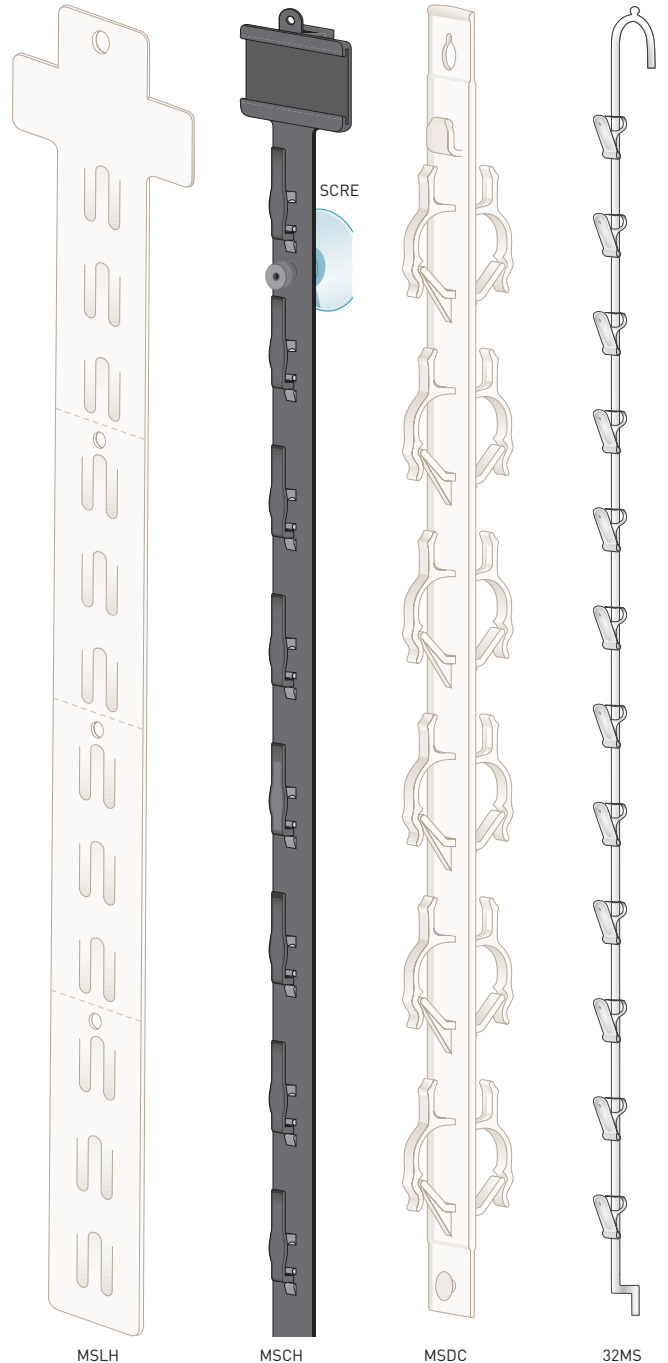

Display Components

Kostklip's display components help organize and manage store inventory. Display components include hang tabs, scanning hooks and sign holding suction cups. Contact us for any other component needs.

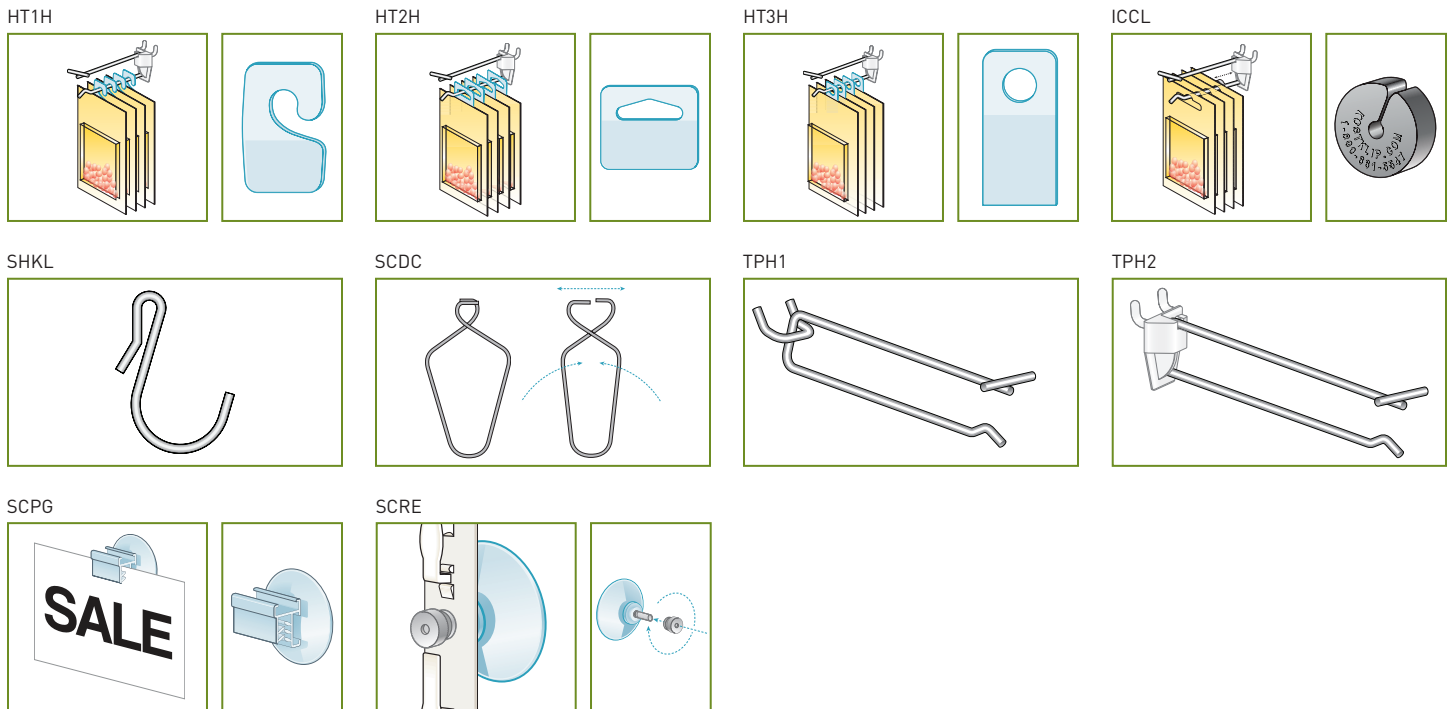

ChalkTalker™ Series

Kostklip's innovative ChalkTalker™ series was designed for retailers looking for an easy-to-use, reusable option to display marketing and promotional messages along the shelf edge. Kostklip's reusable **ChalkTalkers™** provide retailers a solution that saves on operational costs, while reducing in-store carbon footprints with non-adhesive in-store signage solutions.

ChalkTalker™ Bib (CVCT & CGCT)



Made from heat-folded recyclable high gloss PVC material for durability. Clips into 1.25" H ClearVision® or ClearGrip™ ticket molding. Create eye-catching messages on the chalkboard surface area of approximately 2.5"W x 1.75"H. The ChalkTalkers™ are freezer and refrigerator temperature compatible.

* Calls us about customization

Under certain circumstances it may be difficult to remove the writing. Recommended alcohol cleaning percentage is 91% USP.

ChalkTalker™ Deli Signs (WBCT)



Made from impact resistant, black PVC for durability. Printed with a woodgrain border to create a rustic look.

* Calls us about customization

ChalkTalker™ Pens (CP01)



Use kostklip's ChalkTalker™ pens on our ChalkTalker™ bibs and deli signs. Easily clean the surface with alcohol spray or wipes. The ink is waterproof and quick-drying.



01. Contact us to find out more information about kostklip's **ChipTalkers™**.

Each kit contains a variety of promotional, health and lifestyle messages.



Signature Series ShelfTalkers™

Signature Series ShelfTalkers™ are colorful, reusable, printed plastic shelf edge signs that are designed to be quickly inserted anywhere along the shelf edge with the built-in grip on kostkclip's ClearGrip™, ClearVision® or Flex Series non-adhesive ticket molding. The result is an eye-catching low cost, professional shelf edge marketing program that can maximize product focus and increase product sales! Use with our 2.5"W x 1.25"H PerfPaper™ (107P-101164).



Comes in Packs of 25



Comes in Packs of 100

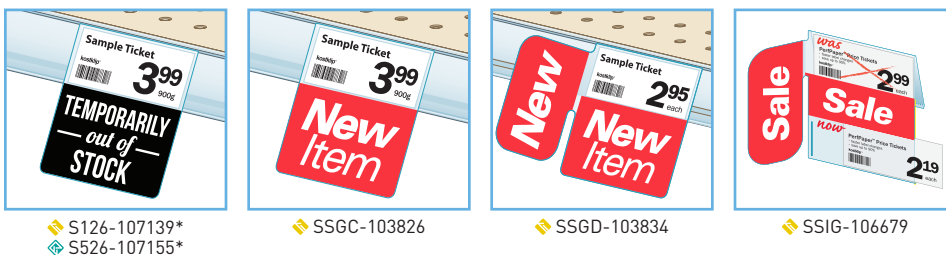

SIGN UP TO OUR NEWSKLIPS

NewsKlips provides industry trends in product merchandising, ways to optimize in-store customer experiences, new product alerts, promotions, and sales as well as contests and giveaways.

* Visit www.kostklip.com and subscribe.

CONTACT US TODAY

Call us today to learn more about our C-Store Merchandising Solutions!

IT'S EASY TO ORDER

CHOOSE ONE OF THE FOLLOWING METHODS:



Call Toll-Free
North America wide
1.800.661.5547



Fax your purchase order to
1.877.468.0007



Visit our website,
log in & order online
www.kostklip.com



Email your purchase order to
sales@kostklip.com



Hours of Operation
7:30 am – 4:00 pm
Pacific Time

kostklip[®]
LIFE AT THE SHELF EDGE

1.800.661.5547 | sales@kostklip.com | www.kostklip.com
119-1611 Broadway St, Port Coquitlam BC V3C 2M7

C-Store_Brochure_2022 | Printed in Canada

FOLLOW US ON



@kostklip



@kostklip



@lifeattheshelfedge



kostklip[®]



kostklip[®]



kostklipShelfEdge