

The background of the entire image is a vibrant red color, densely covered with numerous water droplets of varying sizes. The droplets are rendered with soft highlights and shadows, giving them a three-dimensional appearance. The overall effect is one of freshness and purity.

SIMFLO[®]

**THE HIGHEST
STANDARDS FLOW
FROM EVERYTHING
WE PRODUCE.**

**WE ARE A
COMPANY
BUILT ON NOT
JUST QUALITY,
BUT PRINCIPLE.**



**OUR FOUNDERS BELIEVED EACH
PRODUCT WE PRODUCE SHOULD BE MADE
WITH THE UTMOST ATTENTION TO DETAIL –**

and that still holds true today.

From utilizing quality foundries to internal machining and manufacturing, virtually every aspect of a **SIMFLO** pump is created to provide the highest level of performance in the industry for our customers.

SIMFLO®

Controlling a well-cast product is an incredible advantage to producing pumps that surpass all others. The expert staff at **SIMFLO** understands the art of pouring hot metal, and uses proven techniques to verify the quality of each cast piece. This attention to detail assures hydraulic performance and a product free of physical defect.

QUALITY THAT KEEPS BUSINESS PUMPING

In-house testing allows **SIMFLO** to maintain the most stringent quality standards possible. **SIMFLO** Quality Assurance procedures were designed and developed by our own engineers and plant supervisors to meet ISO-9001 standards. With testing facilities at multiple **SIMFLO** locations, we're able to test pumps with a maximum flow of 30,000 GPM and electrical service up to 1,000 HP.

SIMFLO'S ENGINEERS ARE SOME OF THE MOST KNOWLEDGEABLE AND INNOVATIVE IN THE PUMPING INDUSTRY

We recognize the importance of delivering the highest quality products to our customers. Our engineering department is equipped with the latest software and resources to design and develop top-tier products for your application. Making **SIMFLO** expertise available to our customers is often key to our project success.

MUNICIPAL



SIMFLO MUNICIPAL SOLUTIONS

SIMFLO pumps were made with your municipal needs in mind. Whether it's a quaint town or part of a bustling metropolplex, our pumps consistently and dependably deliver the water you need to keep your city running.

MUNICIPAL PUMP APPLICATIONS INCLUDE:

MUNICIPAL WATER SERVICE

RAIN WATER

BACKWASH WATER

HIGH-SERVICE BOOSTER PUMPS

RECHARGE WATER

TRANSFER

WASTEWATER

EFFLUENT

RECLAIMED WATER

TRANSFER



Certified to
NSF/ANSI/CAN 61
& NSF/ANSI 372

INDUSTRIAL.

MADE IN USA

SIMFLO INDUSTRIAL SOLUTIONS

SIMFLO pumps are perfect for all of your industrial needs. Knowledgeable staff, along with available special materials and constructions, makes our pumps suitable for any of your applications. Our pumps consistently and dependably deliver the aid to keep your operation moving.

INDUSTRIAL PUMP APPLICATIONS INCLUDE:

OIL & GAS

API
FRACKING
OFFSHORE DRILLING
TRANSFER

HVAC-R

COOLING TOWERS
TRANSFER

MINING

DEWATERING
TRANSFER
TRUCK WASHING STATIONS

GOLF COURSES

IRRIGATION
SUPPLY
WATER FEATURE



AGRICULTURAL.



SIMFLO AGRICULTURAL SOLUTIONS

SIMFLO pumps excel at satisfying your farming and agricultural needs. Our pumps consistently and dependably deliver the water you need to feed small and large-scale irrigation and livestock systems.

AGRICULTURAL PUMP APPLICATIONS INCLUDE:

IRRIGATION

CENTER PIVOT

DRIP

SPRINKLER

FURROW

LIVESTOCK

CATTLE

POULTRY

DAIRY

HOG

**THE QUALITY OF OUR
PUMPS IS MATCHED ONLY
BY OUR COMMITMENT TO
CUSTOMER SERVICE.**

SIMFLO

OPEN LINESHAFT

VERTICAL TURBINE PUMP

Our Open Lineshaft Vertical Turbine Pump is engineered to meet a wide variety of applications. Featuring custom materials and configurations, our products are manufactured and tested in adherence with our quality management system, ensuring you will receive the best product in the industry.

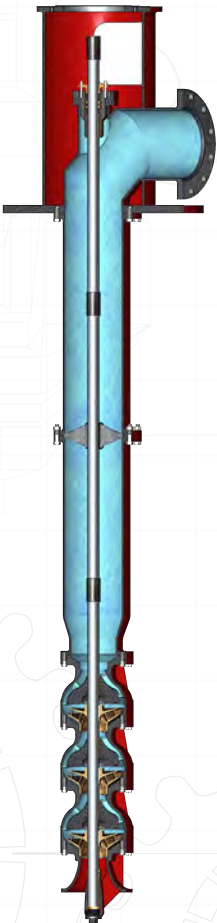

- AVAILABLE IN SIZES 4" - 28" WITH FLOWS FROM 50 - 18,000 GPM
- C955 NICKEL ALUMINUM BRONZE IMPELLERS AS WELL AS 316 STAINLESS STEEL IMPELLERS AVAILABLE
- BOWL CASTINGS FEATURE THICKER WALLS FOR HIGHER PRESSURE RATINGS AND LONGER WEAR LIFE
- CLASS 30 AND DUCTILE IRON CAST DISCHARGE HEADS ARE STOCKED FOR IMMEDIATE SHIPMENT
- FABRICATED DISCHARGE HEADS ARE DESIGNED AND CUSTOM BUILT PER YOUR SPECIFICATION
- AVAILABLE WITH PACKING GLAND OR MECHANICAL SEAL ARRANGEMENTS
- COMPONENTS ARE AVAILABLE IN A WIDE VARIETY OF MATERIALS TO SUIT THE NEEDS OF YOUR UNIQUE APPLICATION

SIMFLO

ENCLOSED LINESHAFT

— VERTICAL TURBINE PUMP —

Our Enclosed Lineshaft Vertical Turbine Pump, featuring a best-in-industry design, is ideal for municipal, industrial, and agricultural applications that require consistent flow rates and unmatched durability.

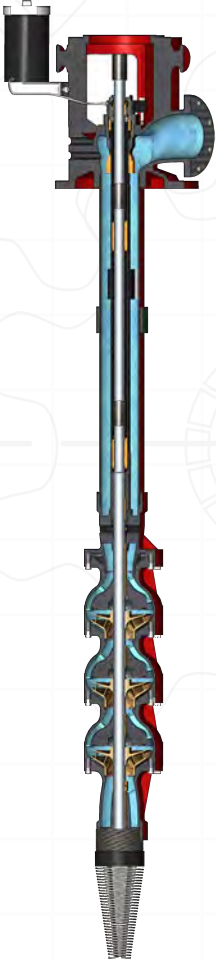

- BOWL MODELS RANGING FROM 4" - 28" WITH FLOWS FROM 50 - 18,000 GPM
- C955 NICKEL ALUMINUM BRONZE IMPELLERS AS WELL AS 316 STAINLESS STEEL IMPELLERS AVAILABLE
- BOWL CASTINGS FEATURE THICKER WALLS FOR HIGHER PRESSURE RATINGS AND LONGER WEAR LIFE
- CLASS 30 AND DUCTILE IRON CAST DISCHARGE HEADS ARE STOCKED FOR IMMEDIATE SHIPMENT
- FABRICATED DISCHARGE HEADS ARE DESIGNED AND CUSTOM BUILT PER YOUR SPECIFICATION
- AVAILABLE WITH PACKING GLAND OR MECHANICAL SEAL ARRANGEMENTS
- COMPONENTS ARE AVAILABLE IN A WIDE VARIETY OF MATERIALS TO SUIT THE NEEDS OF YOUR UNIQUE APPLICATION
- PRESSURIZED OR RECIRCULATING FLUSH AVAILABLE WITH PACKING GLAND OR MECHANICAL SEAL ARRANGEMENT

SIMFLO

SIMFLO

SUBMERSIBLE

PUMP

Durability meets versatility when it comes to our submersible pump. **SIMFLO'S** dedication to using robust, cast bowl and impeller components sets our product apart from the competition. This configuration can handle high head requirements, vertical to horizontal installations and is the perfect choice when operating under surface noise restrictions.



- BOWL MODELS RANGING FROM 4" - 28" WITH FLOWS FROM 50 - 18,000 GPM
- C955 NICKEL ALUMINUM BRONZE IMPELLERS AS WELL AS 316 STAINLESS STEEL IMPELLERS AVAILABLE
- BOWL CASTINGS FEATURE THICKER WALLS FOR HIGHER PRESSURE RATING AND LONGER WEAR LIFE
- FABRICATED DISCHARGE HEADS ARE DESIGNED AND CUSTOM BUILT PER YOUR SPECIFICATION
- COMPONENTS ARE AVAILABLE IN A WIDE ARRAY OF MATERIALS TO SUIT THE NEEDS OF YOUR UNIQUE APPLICATION



SIMFLO

HI/LO SERIES

PUMPS

This proven construction is perfect for a wide variety of installations and is maintained in stock for your well supply needs.

"S"

SERIES



- STAINLESS STEEL CONSTRUCTION
- STAINLESS STEEL DISCHARGE WITH BUILT-IN CHECK VALVE
- HIGH-EFFICIENCY STAINLESS STEEL IMPELLERS AND DIFFUSERS
- STAINLESS STEEL SUCTION SCREEN
- STAINLESS STEEL SHAFT AND COUPLING
- STAINLESS STEEL NEMA FACED MOUNTING BRACKET
- AVAILABLE IN 4", 6", 8", AND 10" DIAMETERS
- CAPACITIES AVAILABLE FROM 5 GPM TO 1200 GPM

"N"

SERIES



- STAINLESS STEEL DISCHARGE WITH BUILT-IN CHECK VALVE
- STAINLESS STEEL MOTOR ADAPTER, CASING, STRAINER AND PUMP SHAFT TO INCREASE DURABILITY
- NORYL IMPELLERS TO INCREASE LIFE IN ABRASIVE CONDITIONS
- DURABLE URETHANE BEARINGS
- AVAILABLE IN 4" DIAMETER
- CAPACITIES AVAILABLE FROM 5 GPM TO 80 GPM

SIMFLO PUMP CONFIGURATIONS

SIMFLO offers a wide variety of pump configurations, alternate materials, and coating options in order to produce the best possible product to keep your business flowing.

HERE ARE SOME OF OUR MOST POPULAR CONFIGURATIONS:

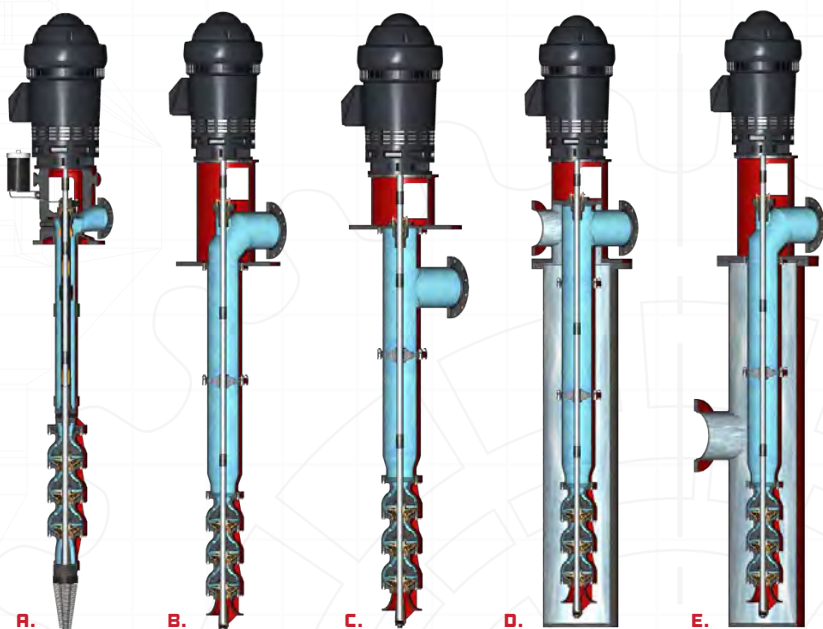

- A.** DEEP WELL PUMP WITH CAST IRON DISCHARGE HEAD
- B.** SHORT COUPLED PUMP WITH FABRICATED STEEL "L" DISCHARGE HEAD
- C.** SHORT COUPLED PUMP WITH FABRICATED STEEL MOTOR STAND AND UNDERGROUND DISCHARGE
- D.** SHORT COUPLED PUMP IN CAN WITH FABRICATED STEEL "T" DISCHARGE HEAD
- E.** SHORT COUPLED PUMP IN CAN WITH FABRICATED STEEL "L" DISCHARGE HEAD

SIMSELECTOR

With a range of 4" - 28" bowls and impellers at speeds of 3600 - 700 RPM, **SIMFLO** has the performance to match your changing applications. With our online **SIMSELECTOR** pump selection software, choosing the right pump configuration is fast and easy.

DPI: DESIGN POINT 1

700.00 GPM X 250.00 FT 83.7% @ 52.80 HP

BASE MULTI ADJ' DYNA'

CONSTANT SPEED - LOCKED

Drag the mouse over the graph for live dynamic results.

SINGLE PUMP PERFORMANCE SL12M-4 / 9.325 / 8.5"

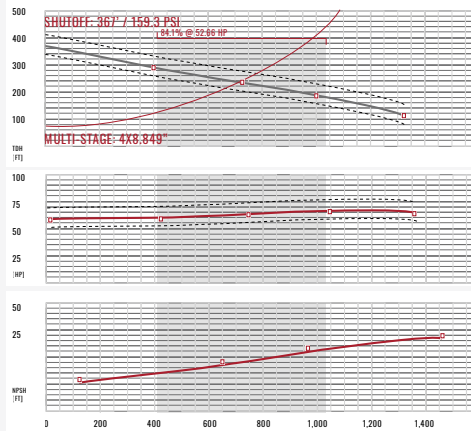

SIMSELECTOR

PUMP SELECTION SOFTWARE

CUSTOM DESIGNS FOR CUSTOM RESULTS.

Design a pumping system unique to your needs with the help of our expert technicians at **SIMFLO.COM**



**CONTACT US
FOR THE TOOLS AND
SERVICE YOU NEED
TO MAKE THE MOST
OF YOUR WATER.**

SIMFLO®



Certified to
NSF/ANSI/CAN 61
& NSF/ANSI 372



LUBBOCK | 2605 INTERSTATE 27 | LUBBOCK, TX | 79404 | 806.747.3411

WILLCOX | 754 E MALEY ST | WILLCOX, AZ | 85643 | 520.384.2273

GARDEN CITY | 2726 W JONES AVE | GARDEN CITY, KS | 67846 | 620.275.4107

SIMFLO.COM

SIM210505