

PRODUCT MANUAL

SKID STEER CONCRETE MIXER



Please read the product manual completely before assembly
Check against the parts list to make sure all parts are received
Wear proper safety goggles or other protective gears while in assembly
Missing parts or questions on assembly?
Please email: info@mechmaxx.com

TABLE OF CONTENTS

● TO THE OWNER.....	2
● SAFETY PRECAUTIONS.....	4
● CONCRETE MIXER ASSEMBLY.....	7
● OPERATION INSTRUCTIONS.....	11
● MAINTENANCE INSTRUCTIONS.....	12
● STORAGE INSTRUCTIONS.....	13
● SPECIFICATIONS.....	14

TO THE OWNER

GENERAL COMMENTS

Congratulations for having this concrete mixer! Your concrete mixer was carefully designed and manufactured to give you years of dependable service. Your concrete mixer will require some minor maintenance (such as cleaning and lubricating) to keep it in top working condition. Be sure to observe all safety precautions and maintenance procedures as described in this manual.

ABOUT THIS MANUAL

This manual has been designed to help you do a better and safer job. Read this manual carefully and become familiar with its contents. Remember, never let anyone operate this unit without reading the "Safety Precautions" and "Operation Instructions" sections of this manual. Unless noted otherwise, right and left sides are determined from the position of the skid steer operator sitting in the seat facing forward.

SERVICE

When service your concrete mixer, pls. remember to use only manufacturer replacement parts. Substitute parts may not meet the standards required for safe, dependable operation. To facilitate parts ordering, pls. record the model No. and serial No. of the metal plate on your unit.

SAFETY PRECAUTIONS

The concrete mixers are designed to be easy to use and maintain. They are operated by the skid steer auxiliary hydraulics. The concrete mixers mount to the toolbar or quick attach mechanism for easy mounting.

BEFORE OPERATION

1. The operator must read the operation manual carefully before installation, operation or maintenance. Improper operation will cause the machine damaged or the operator dead.
2. Read all the safe signs and safe declarations. Obey all the professional safe terms, local laws or the professional directions.
3. Familiar with the concrete mixer about functions, specs and operation. Replace the to-be-damaged parts in time. Make sure all the hydraulic installations and couplings connect firmly, and all the safe signs stick on the suitable positions clearly.

TO THE OPERATOR

WARNING! PROTECT AGAINST FLYING DEBRIS



Always wear proper safety glasses, goggles, or a face shield when driving pins in or out, or when any operation causes dust, flying debris, or any other hazardous material.

2. Don't modify the concrete mixer casually.
3. Should keep the machine on the flat ground when repair, far away from the transportation and other dangerous places.
4. Should use the right tools to repair.
5. Don't operate the machine, unless you are professional, have certificates, and familiar with its functions, specs and safe operation rules.
6. Must not leave the machine when the machine is running. Must stop the engine at first and then remove the key if want to leave.

SAFETY PRECAUTIONS

These are common practices that may or may not be applicable to the products described in this manual.

Safety at All Times

Thoroughly read and understand the instructions given in this manual before operation. Refer to the "Safety Label" section, read all instructions noted on them.

Do not allow anyone to operate this equipment who has not fully read and comprehended this manual and who has not been properly trained in the safe operation of the equipment.

- ▲ The operator must not use drugs or alcohol as they can change the alertness or coordination of that person while operating equipment. The operator should, if taking over-the-counter drugs, seek medical advice on whether he/she can safely operate the equipment.
- ▲ Operator should be familiar with all functions of the unit.
- ▲ Make sure all guards and shields are in place and secured before operating implement.
- ▲ Keep all persons away from equipment and work area.
- ▲ Start skid steer with steering levers and hydraulic controls in neutral.
- ▲ Operate implement and loader arms from the driver's seat only.
- ▲ Dismounting from a moving unit can cause serious injury or death.
- ▲ Do not allow anyone to stand between skid steer and implement while hooking-up to implement.
- ▲ Keep hands, feet, and clothing away from power-driven parts.
- ▲ Watch out for objects overhead and along side such as fences, buildings, wires, trees, limbs, etc., while transporting and operating attached implement.
- ▲ Detach and store implement in an area where children normally do not play. Secure implement by using blocks and supports.

Look For The Safety Alert Symbol



The SAFETY ALERT SYMBOL indicates there is a potential hazard to personal safety involved and extra safety precaution must be taken. When you see this symbol, be alert and carefully read the message that follows it. In addition to design and configuration of equipment, hazard control, and accident prevention are dependent upon the awareness, concern, prudence, and proper training of personnel involved in the operation, transport, maintenance, and storage of equipment.

Be Aware of Signal Words

A Signal word designates a degree or level of hazard seriousness. The signal words are:

DANGER

Indicates an imminently hazardous situation which, if not avoided, will result in death or serious injury. This signal word is limited to the most extreme situations, typically for machine components that, for functional purposes, cannot be guarded.

WARNING

Indicates a potentially hazardous situation which, if not avoided, could result in death or serious injury, and includes hazards that are exposed when guards are removed. It may also be used to alert against unsafe practices.

CAUTION

Indicates a potentially hazardous situation which, if not avoided, may result in minor or moderate injury. It may also be used to alert against unsafe practices.

For Your Protection

- ▲ Thoroughly read and understand the "Safety Label" section, read all instructions noted on them.

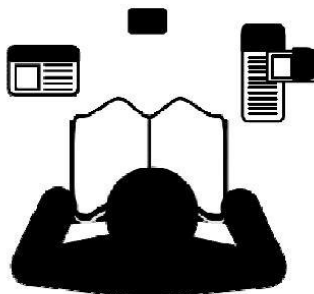

Avoid Underground Utilities

▲ Dig Safe

- Always contact your local utility companies (electrical, telephone, gas, water, sewer, and others) before digging so that they may mark the location of any underground services in the area.
- ▲ Be sure to ask how close you can work to the marks they positioned.



SAFETY PRECAUTIONS

These are common practices that may or may not be applicable to the products described in this manual.

Shutdown and Storage

Before leaving operator's seat:

- ▲ Lower lift arms and put attachment flat on the ground.
- ▲ Turn off engine and engage parking brake.
- ▲ If included, raise seat bar and move controls until both lock.
- ▲ Remove key to prevent unauthorized starting.
- ▲ Use steps, grab-handles and anti-slip surfaces when getting on or off the loader.
- ▲ Detach and store implements in an area where children normally do not play. Secure implement by using blocks and supports.

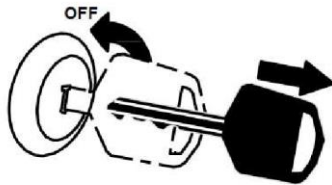

Transport Safety

- ▲ Comply with state and local laws.
- ▲ Never travel at a speed which does not allow adequate control of steering and stopping. Some rough terrains require a slower speed.
- ▲ Avoid contact with any over head utility lines or electrically charged conductors.
- ▲ Always drive with load on end of loader arms low to the ground.
- ▲ Always drive straight up and down ramps with load on "uphill" side of skid steer.
- ▲ Engage parking brake when stopped on an incline.

- ▲ **IMPORTANT:** Do not tow a load That is more than double the weight of the vehicle towing the load.
- ▲ Use towing vehicle and trailer of adequate size and capacity. Secure equipment towed on a trailer with tie downs and chains.
- ▲ Sudden braking can cause a towed trailer to swerve and upset. Reduce speed if towed trailer is not equipped with brakes.



Use Safety Lights and Devices

- ▲ Slow moving self-propelled equipment, and towed implements can create a hazard when driven on public roads. They are difficult to see, especially at night.
- ▲ Flashing warning lights and turn signals are recommended whenever driving on public roads.

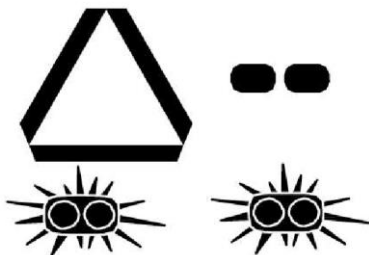

Practice Safe Maintenance

- ▲ Understand procedure before doing work. Use proper tools and equipment, refer to Operator's Manual for additional information.
- ▲ Work in a clean dry area.
- ▲ Lower attached implement to the ground and follow all shutdown procedures before leaving the operator's seat to perform maintenance.
- ▲ Allow implement to cool completely before working on it.
- ▲ Disconnect battery ground cable (-) before servicing or adjusting electrical systems or before welding on implement.
- ▲ Do not grease or oil implement while it is in operation.
- ▲ Inspect all parts. Make sure parts are in good condition & installed properly.
- ▲ Remove buildup of grease, oil, or debris.
- ▲ Remove all tools and unused parts from implement before operation.



SAFETY PRECAUTIONS

These are common practices that may or may not be applicable to the products described in this manual.

Prepare for Emergencies

- ▲ Be prepared if a fire starts.
- ▲ Keep a first aid kit and fire extinguisher handy.
- ▲ Keep emergency numbers for doctor, ambulance, hospital, and fire department near phone.



Wear Protective Equipment

- ▲ Wear protective clothing and equipment appropriate for the job. Clothing should be snug fitting without fringes and pull strings to avoid entanglement with moving parts.
- ▲ Prolonged exposure to loud noise can cause hearing impairment or hearing loss. Wear suitable hearing protection such as earmuffs or earplugs.
- ▲ Operating equipment safely requires the operator's full attention. Avoid wearing radio headphones while operating machinery.



Avoid High Pressure Fluids Hazard

- ▲ Escaping fluid under pressure can penetrate the skin causing serious injury.
- ▲ Avoid the hazard by relieving pressure before disconnecting hydraulic lines or performing work on the system.
- ▲ Make sure all hydraulic fluid connections are tight and all hydraulic hoses and lines are in good condition before applying pressure to the system.
- ▲ Use a piece of paper or cardboard, NOT BODY PARTS, to check for suspected leaks.
- ▲ Wear protective gloves and safety glasses or goggles when working with hydraulic systems.
- ▲ **DO NOT DELAY.** If an accident occurs, see a doctor familiar with this type of injury immediately. Any fluid injected into the skin or eyes must be treated within a few hours or gangrene may result.



Tire Safety

- ▲ Tire changing can be dangerous and should be performed by trained personnel using the correct tools and equipment.
- ▲ When inflating tires, use a clip-on chuck and extension hose long enough to allow you to stand to one side and NOT in front of or over the tire assembly. Use a safety cage if available.
- ▲ When removing and installing wheels, use wheel handling equipment adequate for the weight involved.



Use Seat Belt and ROPS

- ▲ Operate only skid steers equipped with a Roll-Over Protective Structure (ROPS) and seat belt.
- ▲ Fasten seat belt snugly and securely to help protect against serious injury or death from falling and skid steer overturn.
- ▲ Wearing protective equipment such as safety shoes, safety glasses, hard hat, and ear plugs is highly recommended.

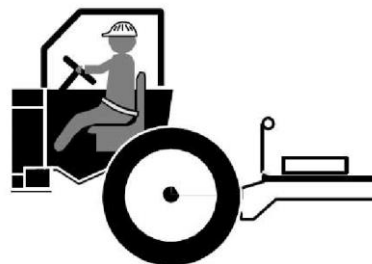

Keep Riders Off Machinery

- ▲ Never carry riders or use Machinery as a person lift.
- ▲ Riders obstruct operator's view.
- ▲ Riders could be struck by foreign objects or thrown from the machine.
- ▲ Never allow children to operate equipment.



CONCRETE MIXER ASSEMBLY

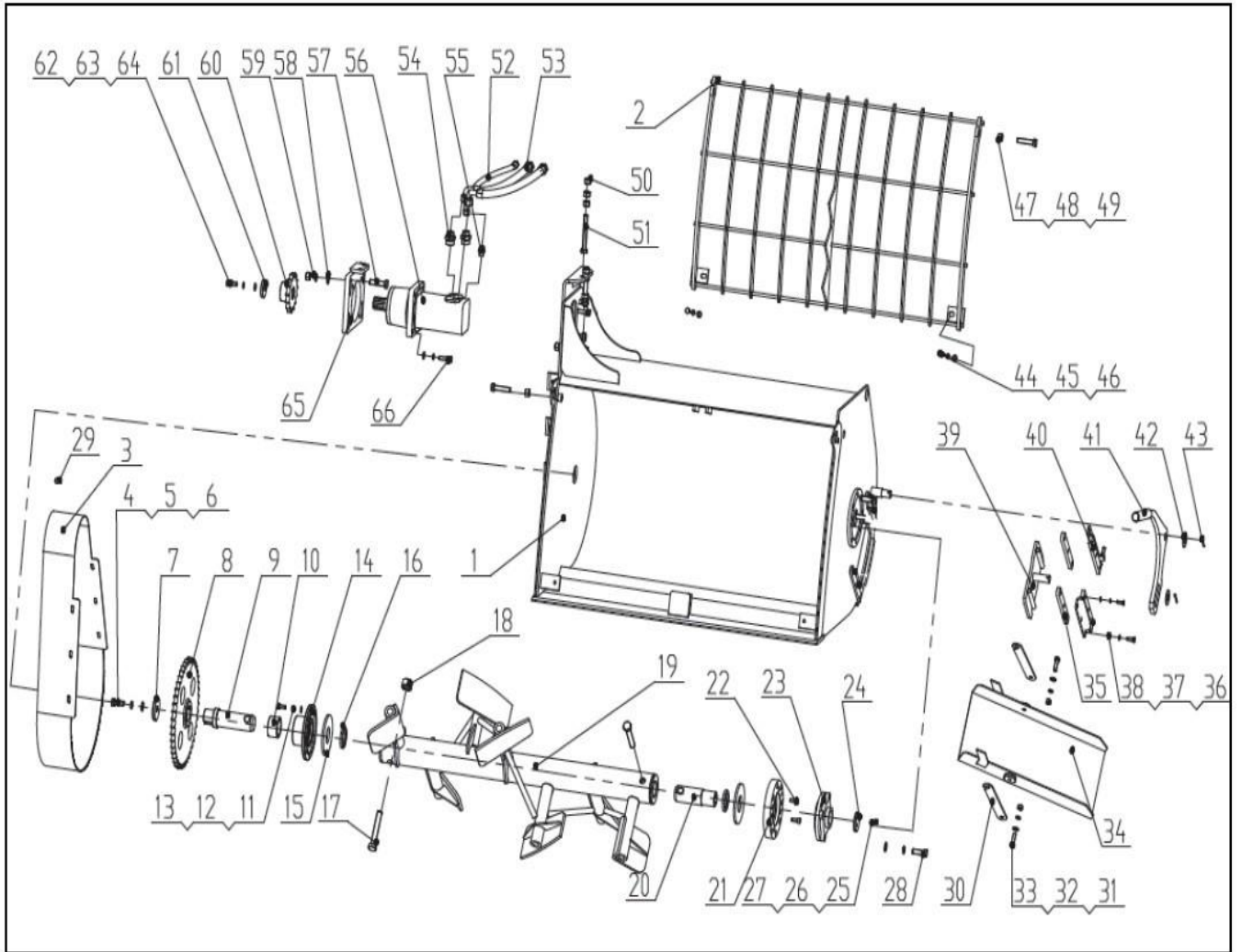

CONCRETE MIXER ASSEMBLY

PART NO.	S/N NUMBER	PART DESCRIPTION	QTYS	NOTE
1	0310L04.01	BUCKET BODY	1	
2	0310L04.04	FENCE	1	
3	0310L04.02	COVER	1	
4	GB5783-2000	BOLT M16X40	1	
5	GB93-1987	SPRING WASHER D16	5	
6	GB97.1-2000	FLAT WASHER D16	5	
7	0310L04.05-01	SPROCKET PRESSING PLATE	1	
8	0310L04.05-02	BIG SPROCKET	1	
9	0310L04.05-04	ROTATING SHAFT	1	
10	55*70-40	BEARING	1	
11	GB5783-2000	BOLT M10X25	8	
12	GB93-1987	SPRING WASHER D10	16	
13	GB97.1-2000	FLAT WASHER D10	8	
14	0310L04.05.01	BEARIGN MOUNTING SEAT	1	
15	0310L04.05-03	RUBBER PLATE	2	
16	B55*72-8	ROTARY LIP SEAL	2	
17	GB5782-2000	BOLT M20X130	2	
18	GB6128-2000	LOCK NUT M20	2	
19	0310L04.05.02	MIXING SHAFT	1	
20	0310L04.05-05	DRIVEN SHAFT	1	
21	0310L04.05-06	END CAP	1	
22	GB70.3-2000	HEXAGON SOCKET HEAD CAP SCREW M10X25	8	
23	GB7810-1995	UCFC210	1	

CONCRETE MIXER ASSEMBLY

PART NO.	S/N NUMBER	PART DESCRIPTION	QTYS	NOTE
24	0310L04.05-07	PRESSING PLATE	1	
25	GB5783-2000	BOLT M8X25	2	
26	GB93-1987	SPRING WASHER D8	2	
27	GB97.1-2000	FLAT WASHER D8	2	
28	GB5783-2000	BOLT M16X50	4	
29	GB5789-2000	BOLT M8X16	6	
30	0310L04.07-01	CONNECTING ROD	2	
31	GB5783-2000	BOLT M12X40	2	
32	GB97.1-2002	FLAT WASHER D12	2	
33	GB6128-2000	LOCK NUT M12	2	
34	0310L04.07.04	DISCHARGE PLATE	1	
35	0310L04.07-02	NYLON PLATE	2	
36	GB5783-2000	BOLT M8X25	6	
37	GB97.1-2002	FLAT WASHER D8	6	
38	GB93-1987	SPRING WASHER D8	6	
39	0310L04.07.02	LOCK GATE	1	
40	0310L04.07.01	PRESSING PLATE	2	
41	0310L04.07.03	HANDLE	1	
42	GB97.1-2002	FLAT WASHER D24	2	
43	GB91-2000	SPLIT PIN D5X60	2	
44	GB5783-2000	BOLT M10X25	2	

45	GB97.1-2002	FLAT WASHER D10	2	
46	GB93-1987	SPRING WASHER D10	2	
47	GB5783-2000	BOLT M16X70	2	
48	GB97.1-2002	FLAT WASHER D16	2	
49	GB6128-2000	LOCK NUT M16	2	
50	GB6170-2000	NUT M16	10	
51	GB5783-2000	BOLT M16X120	2	

CONCRETE MIXER ASSEMBLY

PART NO.	S/N NUMBER	PART DESCRIPTION	QTYS	NOTE
52	F381CACA101005-2000	OIL HOSE	1	
53	F381CACF181810-2000	OIL HOSE	2	
54	IE18LM33X2ED	JOINT	2	
55	IE10LM14X1.5ED	JOINT	1	
56	F6KW	MOTOR	1	
57	GB5783-2000	BOLT M16X65	4	
58	GB93-1987	SPRING WASHER D16	4	
59	GB97.1-2000	FLAT WASHER D16	8	
60	0310L04.03-02	BIG SPROCKET	1	
61	0310L04.03-01	PRESSING PLATE	1	
62	GB5783-2000	BOLT M12X35	1	
63	GB93-1987	SPRING WASHER D12	5	
64	GB97.1-2000	FLAT WASHER D12	5	
65	0310L04.03.01	MOTOR MOUNTING BASE	1	
66	GB5783-2000	BOLT M12X45	4	

OPERATION INSTRUCTIONS

The concrete mixer has the lateral discharge hole with manual opening. It can help to realize much more quickness and high efficiency to discharge the material. Attach the concrete mixer to the toolbar or quick attach mechanism of your skid steer loader.

RAISING OR LOWERING THE CONCRETE MIXER

raise or lower the concrete mixer by raising or lowering the skid steer loader arms through their appropriate skid steer controls.

THEORY OF OPERATION

The mixing shaft rotates around its axis generating a convective movement of the material, which is therefore perfectly mixed due to the special design of the auger flights. Connected through a chain drive, and orbital hydraulic motor transfers motion to the shaft. The material is constantly pushed toward the left side where it can be discharged through the lateral discharge hole with manual opening.

The capacity of mixing material is up to rated lifting capacity of the skid steer loader and the concrete weight per cubic meter.

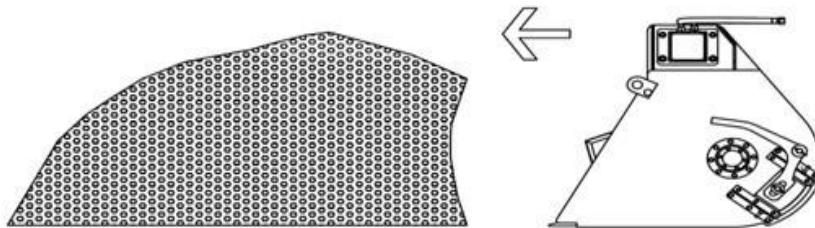

PAY ATTENTION TO THE FORBIDDEN ITEMS

- Mix the asphalt.
- Mix the material with a diameter over 20mm.
- Any kind of grinding activity.
- Use the mixer to dig, tow, pull or tear.
- Put hands inside the mixer or slide tools into the mixer during operation.
- Remove the protection of the grill

MAINTENANCE INSTRUCTIONS

1. Always keep the clean hydraulic oil, keep the hose joint clean, if the hydraulic oil is mixed with dirt, it will possibly cause the whole operation system abnormally.
2. Daily check all hydraulic lines, make sure the connection of the hydraulic line good, the pipe without distortion, wear, cracking, no loose joint to leak.
3. Daily inspect the concrete mixer oil level, and refuel timely.
4. Daily inspect all parts of the machine, make sure all the parts are connected stably and reliably.
5. If the paint off or damage, repaint timely, to prevent rust.
6. The gear chain should be lubricated every 3 months.

STORAGE INSTRUCTIONS

1. Clean all the debris, all mud, dirt and grease.
2. Inspect the unit for bent, loose, cracked, damaged or missing parts, Order any parts required, and make the necessary repairs to avoid delays when starting next season.
3. Tighten all loose nuts, bolts, screws and hydraulic connections.
4. Touch up all the unpainted and exposed areas with paint to prevent rust.
5. Replace security labels and tags if damaged, or in unreadable condition.
6. Connect the hydraulic couplers together or use the oil nuts to block the hydraulic hoses.
7. Check the motor for proper lubricant level.

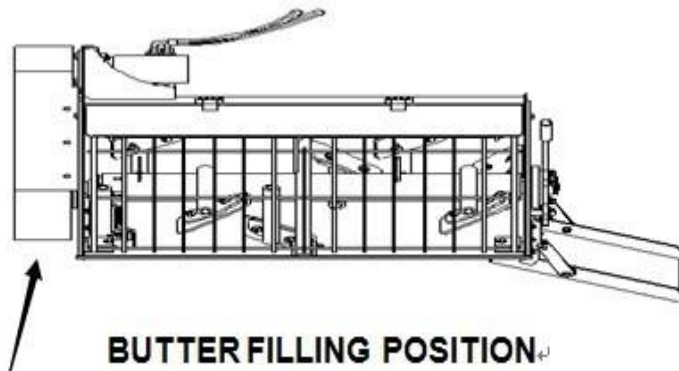

8. Should put the device in the dry non-corrosive place. If in nude outside, will shorten its life.

SPECIFICATION

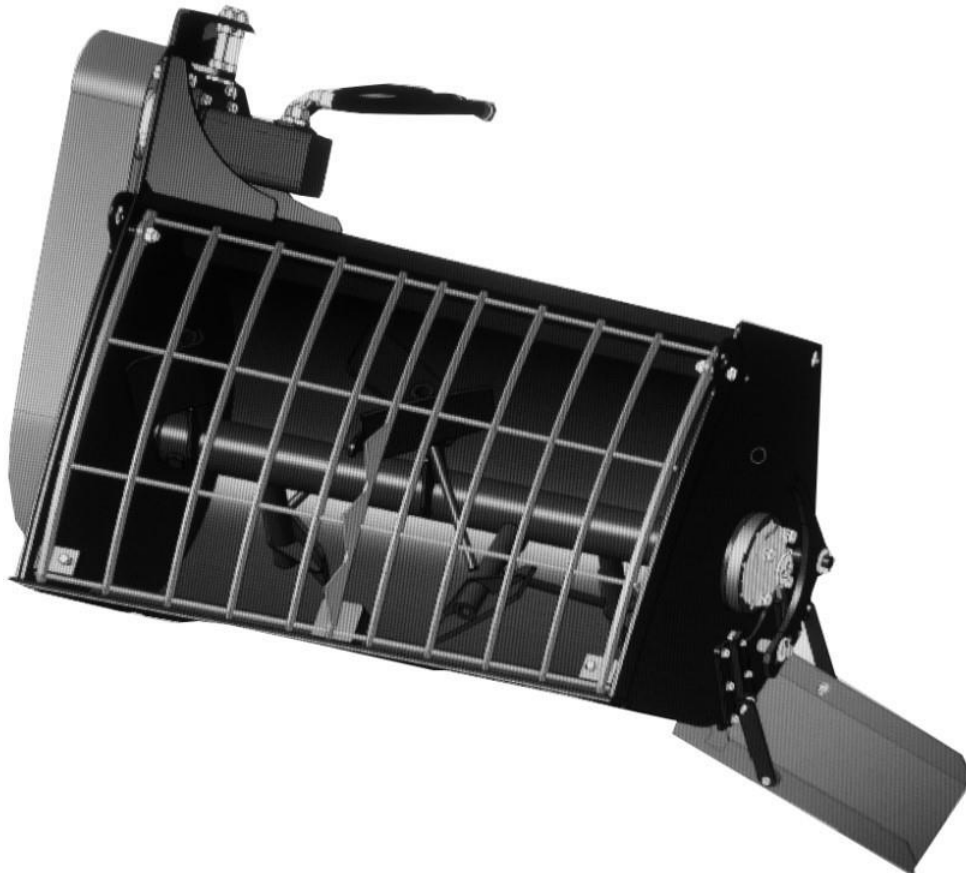

MODEL	150108
TOTAL LENGTH	43.3 in
TOTAL WIDTH	73.8 in
TOTAL HEIGHT	43.3 in
TOTAL WEIGHT	992 lbs
BUCKET CAPACITY (CBM)	0.45
SYSTEM FLOW (L/MIN)	60-110
MAX. PRESSURE (MPA)	16-21
DISCHARGING MATERIAL FORM	FRONT OR SIDE DISCHARGING