

Rhinoceros XN08 / XN12 Mini Digger Overall Dimensions

OVERALL DIMENSIONS	UNIT: MM
A Wheel Base	770
B Overall Length of Track	1,090
C Ground clearance of platform	380
D Ground clearance of platform tail	784
E Chassis Width	896
F Crawler Width	170
G Crawler Height	320
H Transportation Length	2,770
I Overall Height	1,330

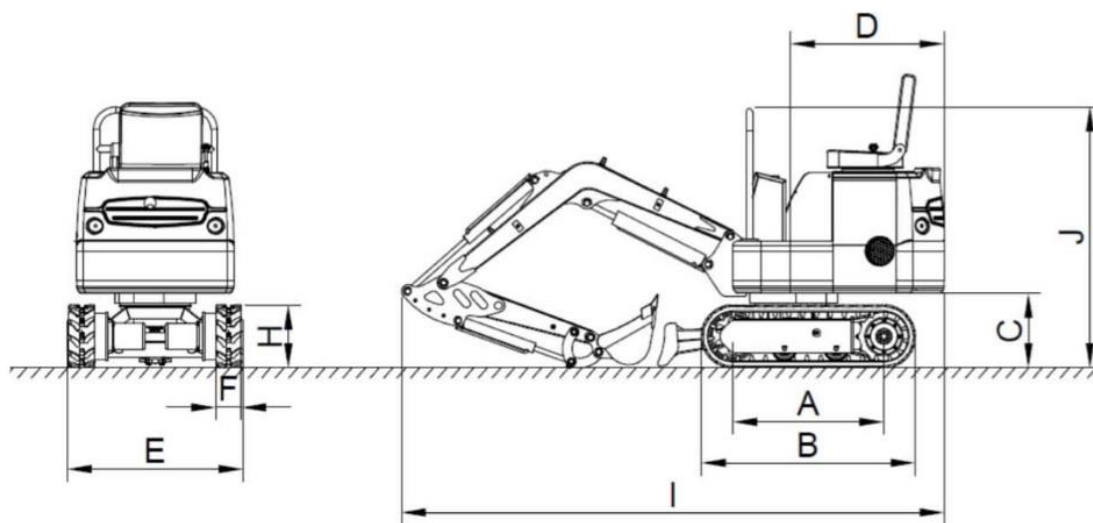

Rhinoceros XN08 / XN12 Mini Digger Operating Parameters

OVERALL DIMENSIONS	UNIT: MM
A Max Digging Radius on Ground	2,850
B Max Digging Depth	1,650
C Max Digging Height	2,610
D Max Unloading Height	1,850
E Max Vertical Digging Depth	1,375
F Min Swing Radius	1,330
G Max Lifting Height of Dozer Blade	345
H Max Digging Depth of Dozer Blade	255

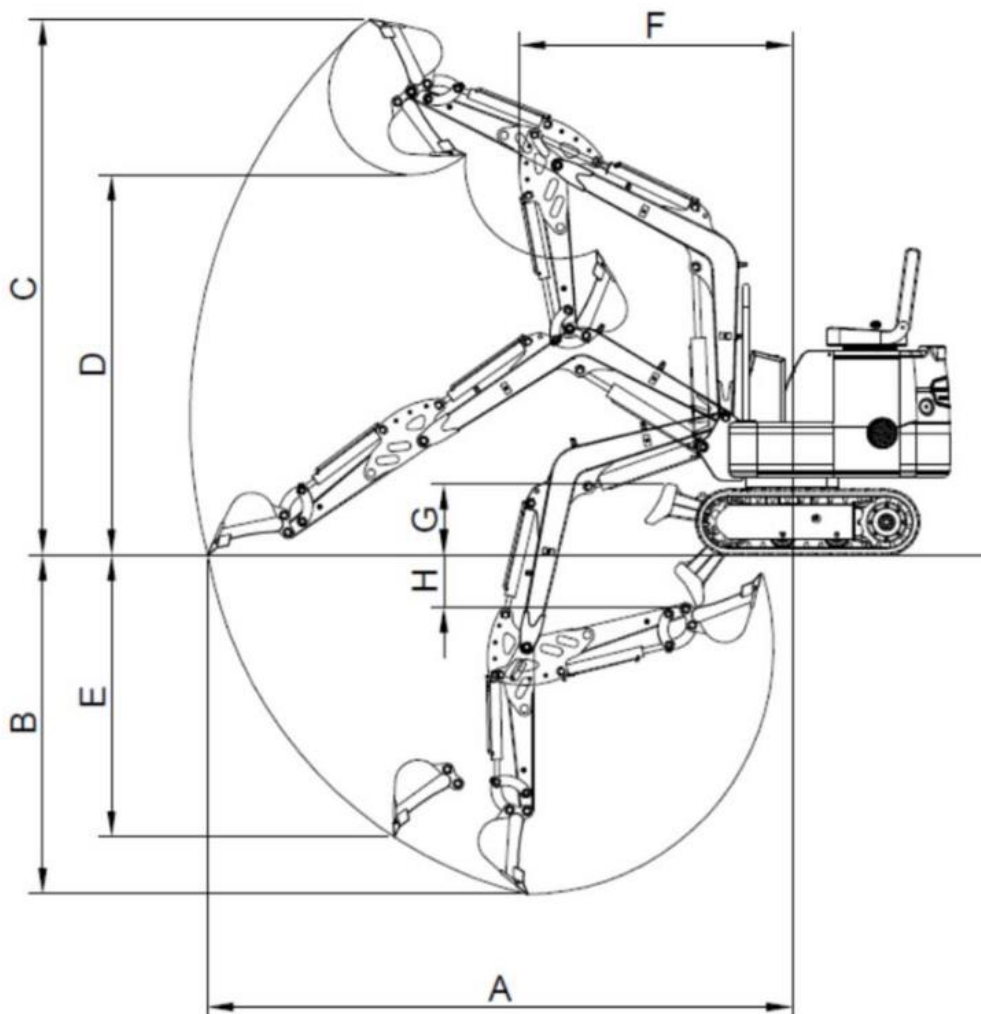



Rhinoceros XN12 – XN12-08 Specifications

Model	XN12
Operating Weight	1,040kg
Digging Bucket Capacity	0.025 cbm / 100kg
Engine	Kubota 3 Cyl D722-E4B Euro 5
Rated Power	14.9kw /3600 rpm
Displacement	0.719 L
Bore Stroke	67 x 68
Main Pump	ZANEDA
Displacement	6.8ml/r
Hydraulic System Pressure	16 MPA
Swing Motor	SJ-TECH (MP-1-160)
Travelling Motor	KERSEN (OMS-2450)
Travel Speed	1.5 kph

Rhinoceros XN12 – XN12-08
Engine Specifications



14.9KW @ 3600rpm

Kubota D722-E4B (2 Year Warranty)