



ASI178 Manual

Revision 1.2

Mar, 2018

All materials related to this publication are subject to change without notice and its copyright totally belongs to Suzhou ZWO CO.,LTD.



Table of Contents

ASI178 Manual	1
1. Instruction	3
2. Camera Models and Sensor Type	4
3. What's in the box?.....	5
4. Camera technical specifications.....	6
5. QE Graph & Read Noise.....	7
6. Getting to know your camera.....	9
6.1 External View.....	9
6.2 Power consumption:.....	10
6.3 Cooling system.....	11
6.4 Protect Window.....	11
6.5 Analog to Digital Converter (ADC).....	12
6.6 Binning.....	12
7. How to use your camera.....	13
8. Clean the camera and redry desiccant.....	16
9. Mechanical drawing.....	17
10. Servicing	18
11. Warranty	18

1. Instruction

Congratulations and thank you for buying one of our ASI Cameras! This manual will give you a brief introduction to your ASI camera. Please read it thoroughly. If you have any other questions, please feel free to contact us. info@zwoptical.com

ASI178 Cameras are designed for astronomical photography.
Its excellent performance and multifunctional usage will impress you a lot!

For software installation instructions and other technical information please refer to “Support” on our official website.
<https://astronomy-imaging-camera.com/>

2. Camera Models and Sensor Type

There are 4 types of ASI178 models:

Models	Mono or Color	Regulated TEC Cooling	Sensor
ASI178MM	Mono	No	IMX178
ASI178MC	Color	No	IMX178
ASI178MM-COOL	Mono	Yes	IMX178
ASI178MC-COOL	Color	Yes	IMX178

Which camera to choose:

Monochrome camera sensors are capable of higher details and sensitivity than color sensors, but you need additional accessories such as filter wheel and filters. The post-processing is more complicated too. So color camera is often recommended for beginner of astrophotographer.

TEC cooling will help to reduce dark current noise for long exposures. For short exposures, such as under one second, the dark current noise is very low. However, cooling is recommended for DSO imaging when long exposures are required.

3. What's in the box?

ASI178MM or ASI178MC



ST4 cable



Camera body



quick guide



USB3.0 cable



1.25" cover



1.25" nose piece

ASI178MM-COOL or ASI178MC-COOL



camera bag



camera body



USB3.0 cable



quick guide



0.5m USB 2.0 cable × 2



1.25" nose piece



1.25" cover

4. Camera technical specifications

Sensor	1 / 1.8"CMOS
Diagonal	8.95mm
Resolution	6.4 Mega Pixels 3096*2080
Pixel Size	2.4 μ m
Image area	7.4mm * 5mm
Max FPS at full resolution	60FPS
Shutter	Rolling shutter
Exposure Range	32 μ s-1000s
Read Noise	1.4-2.2e
QE peak	TBD
Full well	15k e
ADC	14 bit
Interface	USB3.0/USB2.0
Adapters	2"/ 1.25"/ M42X0.75
Protect window	AR/IR-CUT window
Dimensions	62mm/78mm
Weight	120g/410g
Back Focus Distance	12.5mm non-cooled 17.5mm cooled
Cooling:	Regulated Two Stage TEC
Delta T	35-40°C below ambient
Cooling Power consumption	12V at 2A Max
Supported OS	Windows, Linux & Mac OSX
Working Temperature	-5°C—45°C
Storage Temperature	-20°C—60°C
Working Relative Humidity	20%—80%
Storage Relative Humidity	20%—95%

5. QE Graph & Read Noise

QE and Read Noise are the most important parameters to measure the performance of a camera. Higher QE and lower Read Noise are needed to improve the SNR of an image.

Mono 178 sensor Relative QE Curve

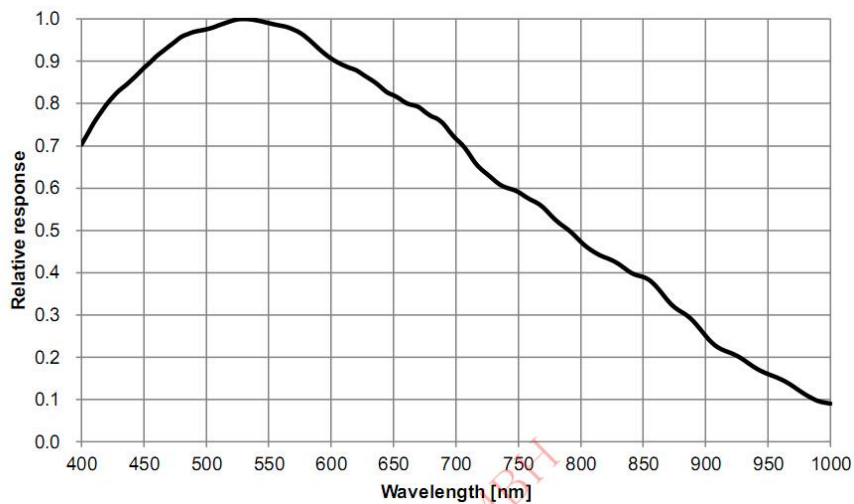

Color 178 sensor Relative QE Curve

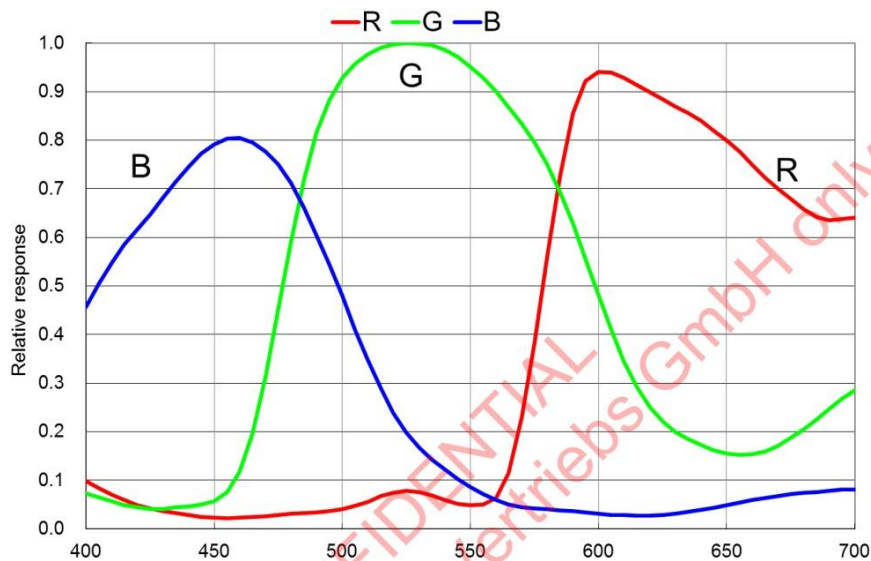

Read Noise includes pixel diode noise, circuit noise and ADC quantization error noise, and the lower the better.

The Read Noise of the ASI178 cameras is extremely lower when compared with traditional CCD cameras. It is even lower when the camera is set at a higher gain.

Depending on your target, you can set the Gain lower for higher Dynamic Range (longer exposure) or set the Gain higher for lower noise (such as short exposure or lucky imaging).

Read noise, full well, gain and dynamic range for ASI178

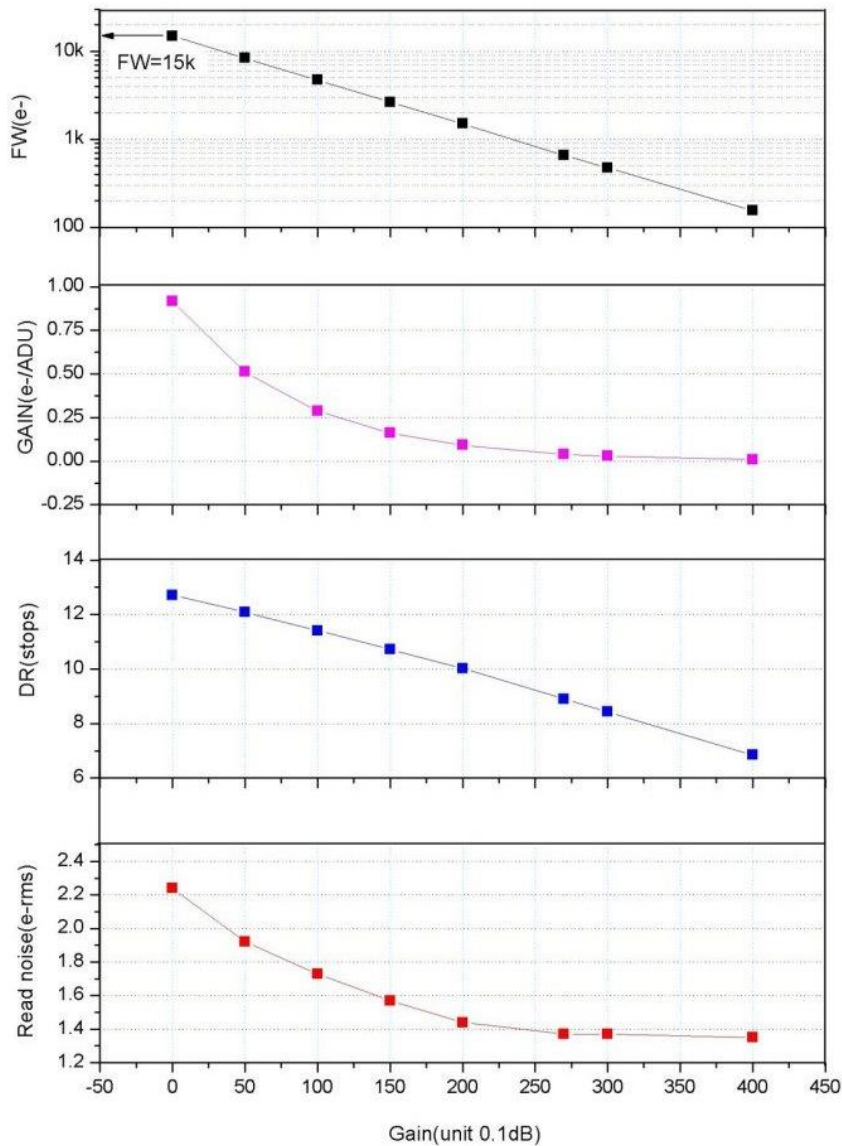

6. Getting to know your camera

6.1 External View



*The first generation of cooled camera we used a ST4 port instead of USB2.0 hub

You can order the [holder ring](#) from us or our dealer to mount the cooled camera to tripod.

There is 1/4" screw under the holder

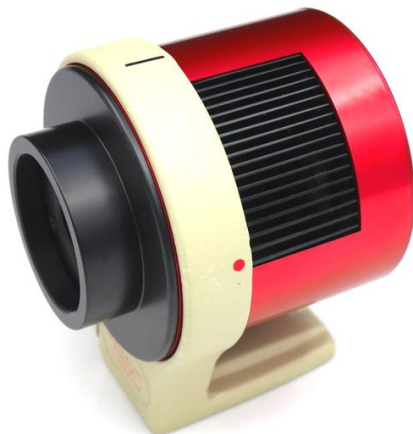

6.2 Power consumption:

ASI cameras are designed to have very low power consumption which is around 170ma@5V. You only need the USB cable to power up the camera. However, you will need a separate power supply to activate the cooler. We recommend 12V at 3A or more AC-DC adapter for cooler power supply (2.1mm*5.5mm, center positive). You may also use a battery supply from 9V to 15V to power the cooler.

Here is a test result of the cooler power consumption of our cooled camera. It only needs 0.5A to cool the camera to 30 degree below ambient.

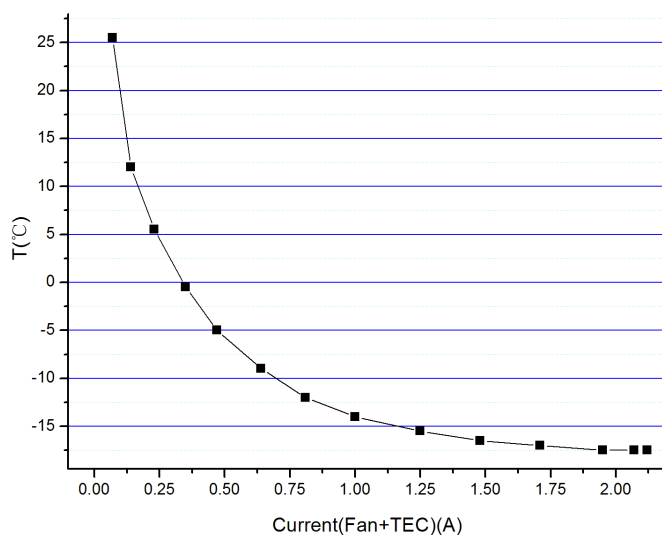

6.3 Cooling system

The cooled ASI178 cameras have a robust, regulated cooling system, which means that the camera sensor can be kept at the desired temperature throughout your imaging session. The super low readout noise, combined with efficient cooling and adjustable gain setting, allows you to do short exposure or lucky DSO imaging, unlike the traditional CCD cameras which need very long exposures for each frame. However, keep in mind that cooling won't help with very short exposures such as less than 100ms. The lowest temperature that can be set is -40°C .

6.4 Protect Window

There is an AR-AR and IR-CUT protect window in ASI178 series camera to prevent the sensor from humidity and dust.

ASI178MM protect window: AR-AR, Dimension 21mm, 1.1mm thickness.

ASI178MM-COOL protect window: AR-AR, Dimension 25mm, 3 mm thickness.

ASI178MC protect window: IR-CUT, Dimension 21mm, 1.1 mm thickness.

ASI178MC-COOL protect window: IR-CUT, Dimension 25mm, 3 mm thickness.

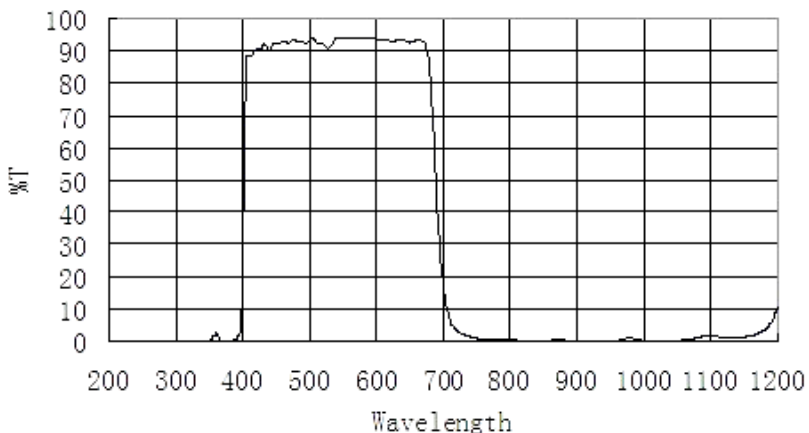

ASI178MM and ASI178MM-C come with the AR protect window.
 Diameter is 21mm (non-cooled version) and 1.1mm thick, 25mm (cooled version) and 2mm thick.
 Transmission chart of the AR filter

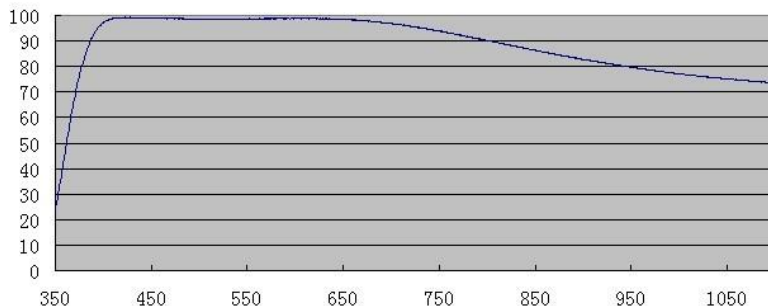

6.5 Analog to Digital Converter (ADC)

The ASI178 camera records in 10bit ADC and 14bit ADC. You can image at a faster fps rate if you choose to use 10bit ADC (high speed mode). This camera also supports ROI (region of interest) shooting, and this smaller ROI has faster fps.

Here is the maximum speed of ASI178 running at 10bit ADC and 14bit ADC.

Resolution	USB3.0	
	10Bit ADC	14Bit ADC
3096×2080	60 fps	30 fps
2560×2048	62 fps	31 fps
2048×1080	116 fps	58 fps
1280×960	130 fps	65 fps
800×600	204.7 fps	102.3 fps
640×480	253.1 fps	126.5 fps
320×240	479.7 fps	239.8 fps

6.6 Binning

The ASI178 camera supports hardware bin2 and bin4 mode. The ASI178 camera supports software bin2, bin3 and bin4 mode. Hardware binning is supported by sensor but is done in digital domain like software binning and use 10bit ADC. The only advantage of hardware binning is faster fps. We recommend customer to use software binning if you don't care speed.

7. How to use your camera

There are many adapters available for this camera for connecting to your scope or lens. Some are included with the camera and others you can order from our site:

Color camera connecting drawing:

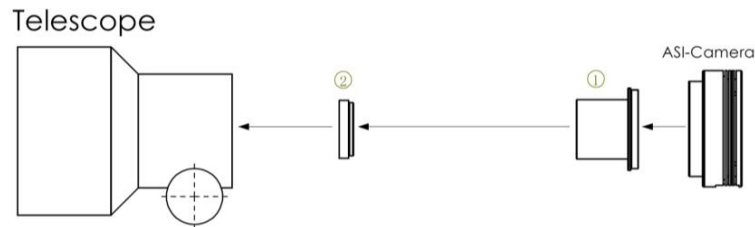

1. 1.25" T-Mount
2. 1.25" filter (optional)

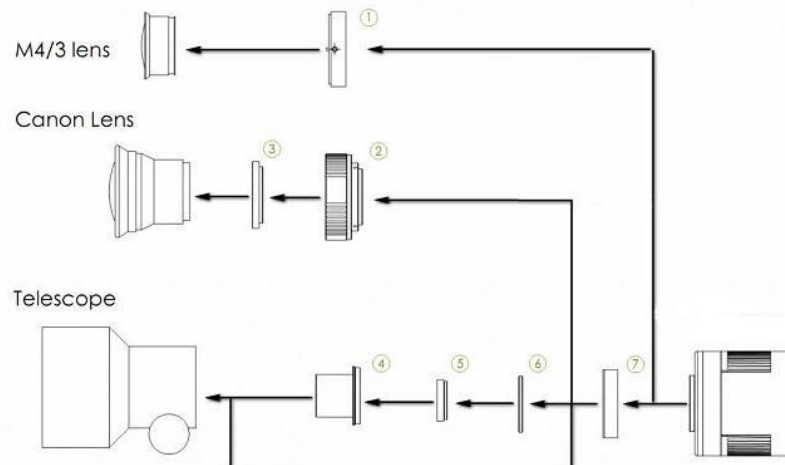

1. M43-T2 adapter
2. EOS-T2 adapter
3. 2" Filter (optional)
4. 1.25" T-Mount
5. 1.25" Filter (optional)
6. M42-1.25" Filter (optional)
7. T2 extender 11mm

Mono camera connecting drawing:

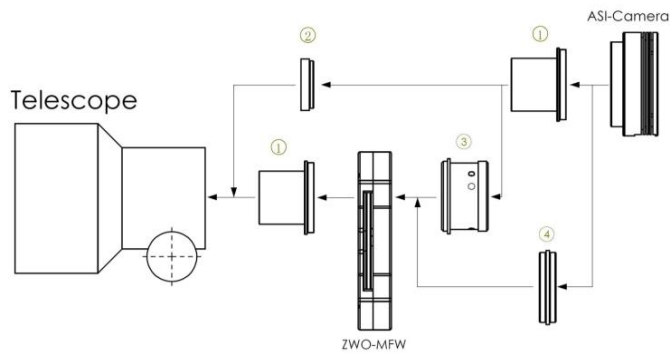

1. 1.25" T-Mount
2. 1.25" filter(optional)
3. M42-1.25" adapter
4. M42-M42 (Male screw thread)

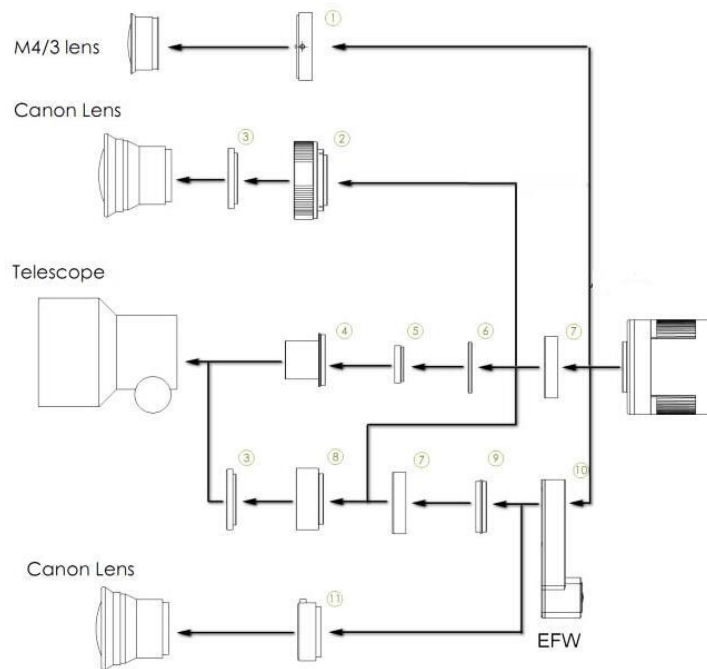

1. M43-T2 adapter
2. EOS-T2 adapter
3. 2"Filter (optional)
4. 1.25" T-Mount
5. 1.25" Filter (optional)
6. M42-1.25" Filter (optional)
7. T2 extender 11mm
8. M42-M48 extender 16.5mm
9. T2-T2 adapter
10. EFW mini
11. EOS adapter for EFW

Planetary/Guide Cameras
External Device Connecting Drawing



Cooled Cameras
External Device Connecting Drawing



8. Clean the camera and redry desiccant

The camera comes with an AR protect window, which can protect the sensor from dust and humidity. Should you need to clean the sensor, it's better to do so during the daytime. To see the dust, you just need to setup your telescope and point it to a bright place. A Barlow is required to see these dusts clear. Then attach the camera and adjust the exposure to make sure not over exposed. You can see an image like below if it's dirty.

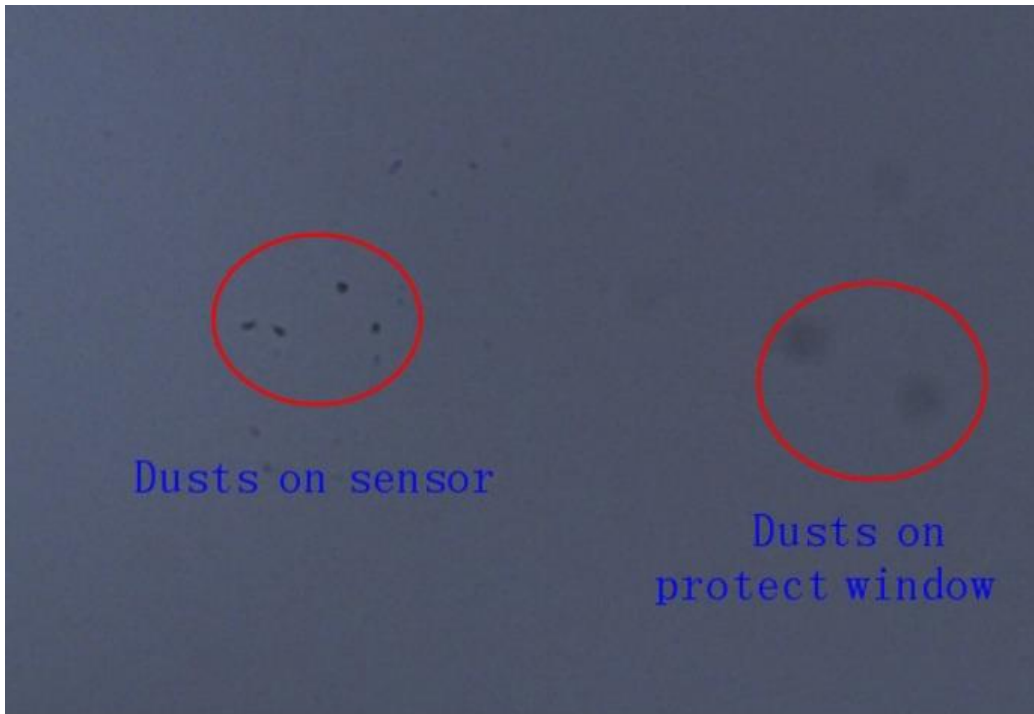

The big dim spot on the image (at right) are the shadows of dust on the protect window.
The very small but very dark spot in the image (at left) are the shadows of the dusts on the sensor.
The suggested way to clean them is try to blow them away with a manual air pump. To clean the dust on the sensor you will need to open the camera chamber.

We have a very detailed instruction on our website:

<https://astronomy-imaging-camera.com/manuals/>

Quickguide

- [ZWO ASI Camera Quick Guide](#)
- [ZWO ASI Cooled Camera Quick Guide](#)
- [How to clean ASI camera and redry the desiccant](#)

9. Mechanical drawing

ASI178MM/ASI178MC

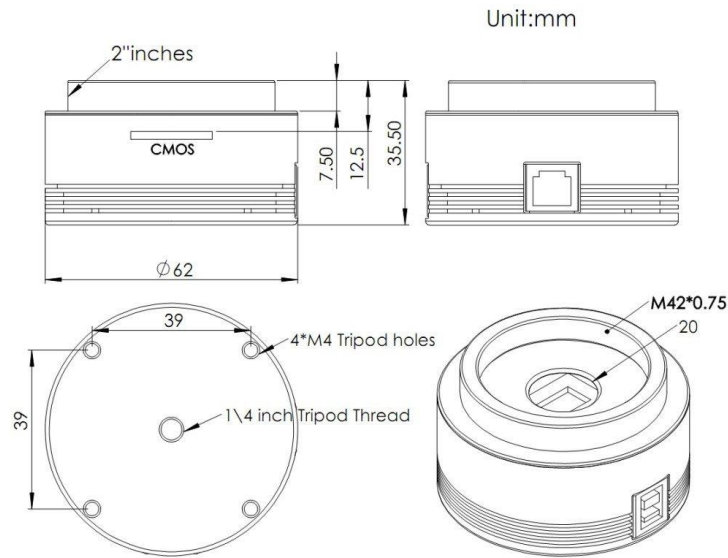

ASI178MM-COOL/ASI178MC-COOL

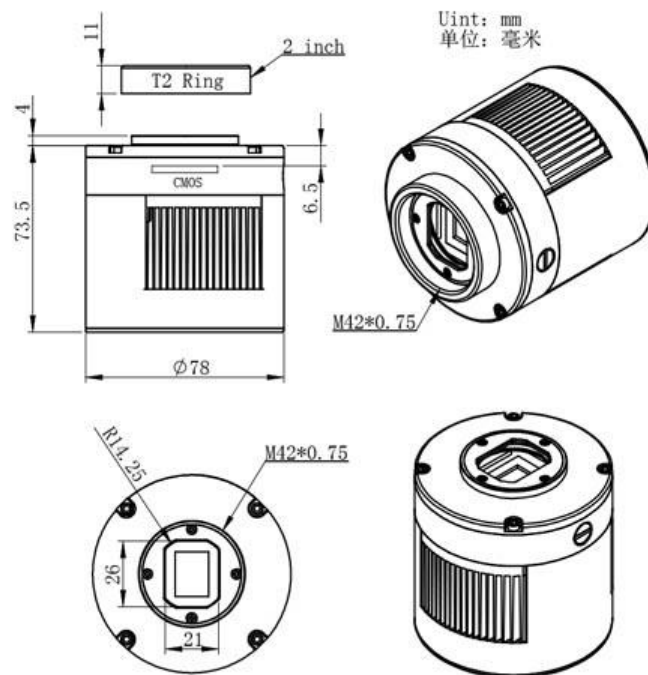

10. Servicing

For software upgrades please refer to “Support-manual and software” on our official website.

<https://astronomy-imaging-camera.com/>

Repairs and servicing are available by emailing info@zwoptical.com

For customers who bought the camera from your local dealer, dealer is responsible for the customer service.

11. Warranty

We provide 2-year warranty for our products. We offer repair service or replacement for free if the camera doesn't work within warranty period.

After the warranty period, we continue to provide repair support and service on a charged basis. This warranty does not apply to damage that occurred as a result of abuse or misuse, or caused by a fall or any other transportation failures after purchase.

Customer must pay for shipping when shipping the camera back for repair or replacement.