

REVISIONS			
REV.	DESCRIPTION	DATE	APPROVED
B	ECN200393B	8/22/2008	

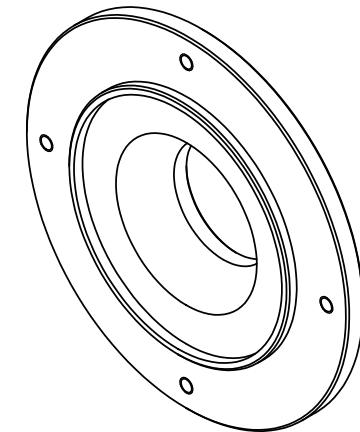
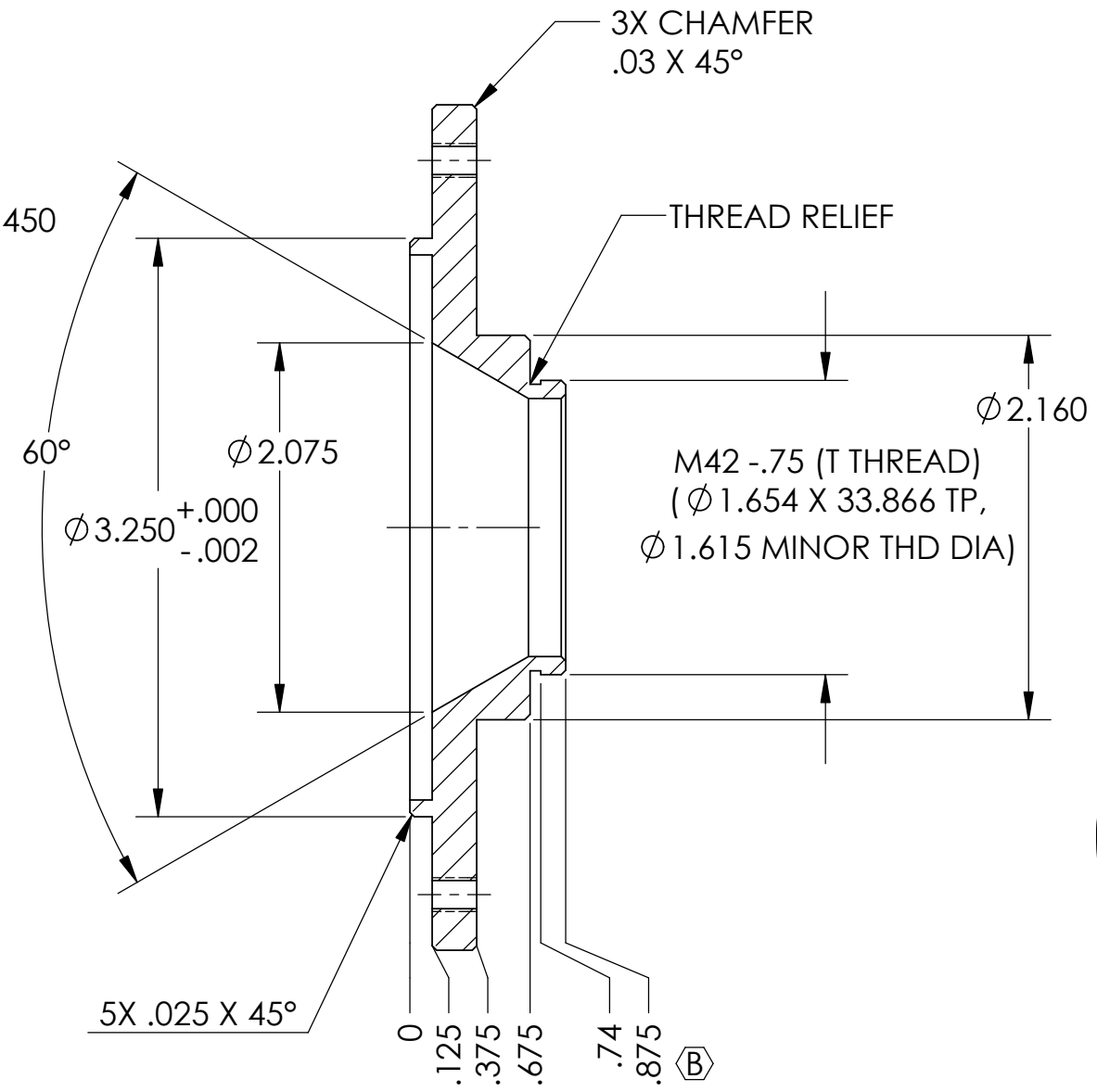
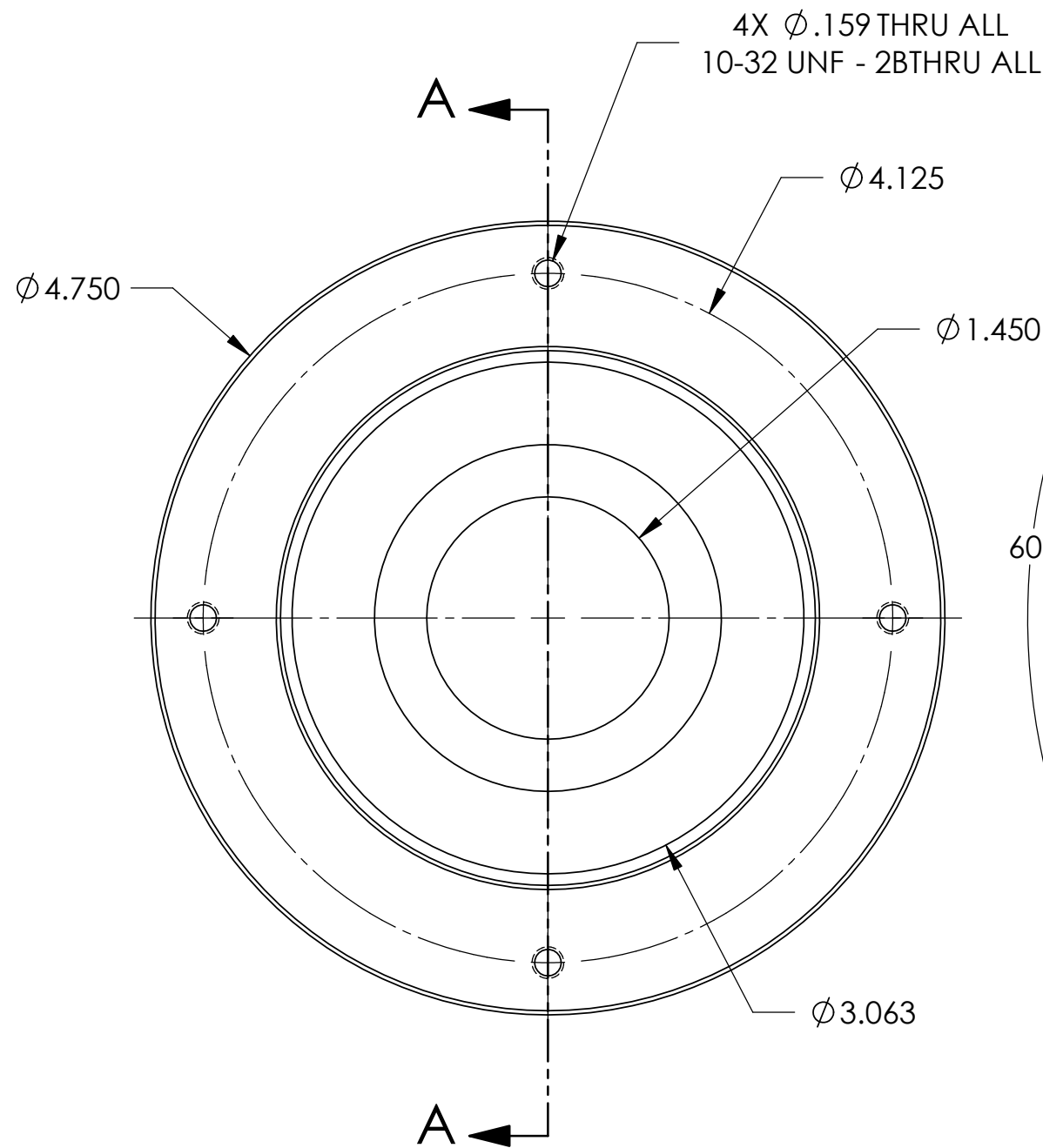

SECTION A-A

NOTES:

1. REMOVE ALL SHARP EDGES.
2. FINISH: SATIN BLACK ANODIZE PER MIL-A-8625, TYPE II, CLASS 2

PROPRIETARY AND CONFIDENTIAL
THE INFORMATION CONTAINED IN THIS DRAWING IS THE SOLE PROPERTY OF PLANEWAVE INSTRUMENTS. ANY REPRODUCTION IN PART OR AS A WHOLE WITHOUT THE WRITTEN PERMISSION OF PLANEWAVE INSTRUMENTS IS PROHIBITED.

UNLESS OTHERWISE SPECIFIED TOLERANCES	
DECIMAL DIM .XXXX±.0005 .XXX±.005 .XX±.02	ANGULAR DIM MACHINED ±0° 30' LOCATING ±0° 30' FORMED ±1° CHAMFERS ±5°
SURFACE FINISH MAX R 0.015	BREAK ALL SHARP EDGES & REMOVE BURRS.

DRAWN	NAME	DATE
CHECKED	W. ZHOU	11/24/2006
ENG APPR.		
MATERIAL 6061-T6 AL ALLOY		
FINISH SEE NOTE		

PLANEwave Instruments		
TITLE SECUREFIT TO T MALE THREAD		
SIZE B	DWG. NO. 200393	REV. B
SCALE: 1:1	CAD FILE: 200393B	SHEET 1 OF 1