

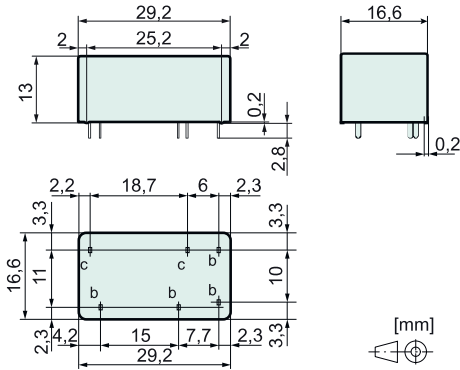

Features

- Relay with forcibly guided contacts according to IEC 61810-3
- Application type A
- Protective separation (see insulation data)
- Suitable for print mounting
- Height only 13 mm
- Contact assembly
SISF112: 1 NO + 1 NC

Dimensions



Pin dimension b	1,0 x 0,3 mm
Pin dimension c	1,0 x 0,4 mm
Recommended drilling on PCB	Ø 1,3 mm

Coil data at 20 °C

Nominal power (typ.)	0,45 W
Holding power (typ.)	0,18 W
Coil limit temperature	120 °C

Nominal voltage (VDC)	Min. Pick-up voltage (VDC)	Min. Drop-out voltage (VDC)	Nominal current (mA)	Resistance (Ohm)
5,0	3,5	0,5	90	56 (1 ± 10 %)
12,0	8,4	1,2	38	320 (1 ± 10 %)
18,0	12,6	1,8	25	720 (1 ± 10 %)
24,0	16,8	2,4	19	1280 (1 ± 10 %)
48,0	33,6	4,8	9	5160 (1 ± 13 %)
60,0	42,0	6,0	8	8000 (1 ± 15 %)

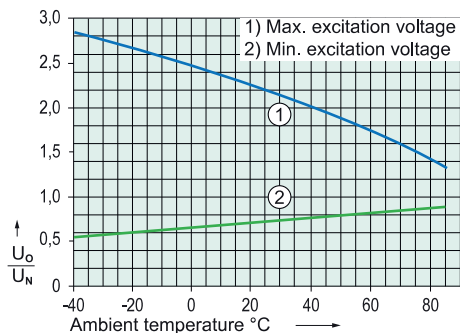

- Test conditions:
- Graph 1: Contact current 4 A MAX
 - Graph 2: without previous operation
 - Free-standing relay on PCB
 - Duty cycle 100%

Contact data

Contact material	AgCuNi + 0,2, ..., 0,4 µm Au
Type of contact	Single contact with notched crown
Rated switching power	1500 VA
250 V / 6 A / AC-1 (max.)	
Electr. life time (0,1 Hz, rel. duty cycle 10%)	90000
Inrush current	30 A for 20 ms
Switching voltage range	5, ..., 250 V DC / AC
Switching current range*	3 mA, ..., 6 A
Switching power range*	40 mW, ..., 1500 W (VA)
Contact resistance as new (max.)	100 mΩ
Short circuit resistance of contacts**	1000 A
with pre-fuse	SCPD 6 A gG / gL (fuse)

* Reference values ** Prospective short-circuit current

Electrical life (NO contacts)

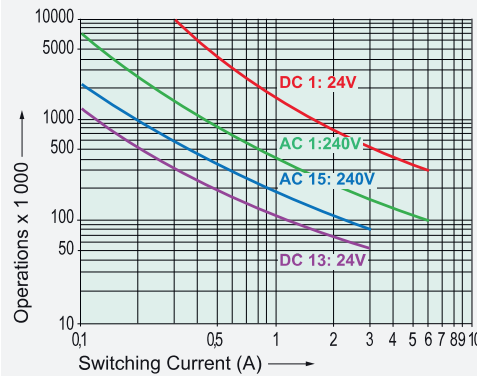

Switching capacity (IEC 61810-1)	
AC-1:	240 V / 6 A MAX
AC-15:	240 V / 3 A MAX
DC-1:	24 V / 6 A MAX
DC-13:	24 V / 3 A / 0,1 Hz MAX
	L/R = 40 ms
Switching capacity (UL 508)	B300, R300
Continuous current per contact at load of:	
1 contact	6 A MAX

Contact load limit curve (DC)

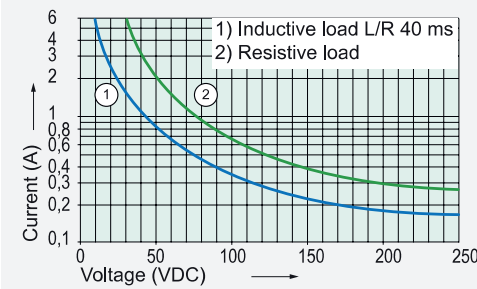

Circuit diagram (top view)

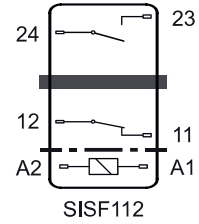

Insulation data

Rated insulation voltage (IEC 60664-1)	250 VAC
Double or reinforced insulation	-----
- Air and creepage distance (min.)	5,5 mm
- Test voltage	4000 V _{rms} / 1 min
Double or reinforced insulation	-----
- Air and creepage distance (min.)	8 mm
- Test voltage	4000 V _{rms} / 1 min
Open contact: Test voltage*	1500 V _{rms} / 1 min
Contact opening: open contact	micro-disconnection
Creepage resistance	CTI 175
Pollution degree	2
Overvoltage category	III
Insulation resistance (min.)	100 MΩ
- Test voltage	500 VDC

* Initial value

Mechanical data

Mechanical lifetime (min.)	10 x 10 ⁶ operations
Switching frequency (max.)	15 Hz
Response time (NO closed) (typ.)	10 ms
Drop-out time (NC closed) (typ.)*	3 ms
Bounce time (typ.)	NO: 2 ms / NC: 15 ms
Shock resistance (16 ms) (min.)	NO: 17g / NC: 10g
Vibration resistance (10-200 Hz) (min.)	NO: 7g / NC: 3g
Weight	approx. 16 g
Mounting position	any
Mounting distance (min.)	5 mm

* without coil wiring

Other data

Ambient temperature	-40 °C, ..., +85 °C
Thermal resistance	45 K / W
Protection class	RT II
Solder bath temperature	270 °C / 5 s
Test method (heating)	A (group assembly)
Approvals	cULus, TÜV
Flammability class	UL 94 V-0
UL File	E503456 Sec.1

Options, Accessories

Other pin lengths	possible
Other coil designs	possible

Product key

SISF	1	1	2	24VDC	XX
SISF	Type designation				
1	Number of contacts NO				
1	Number of contacts NC				
2	Connection technology	2 = Solder terminals			
24VDC	Nominal coil voltage				
XX	Options				