

1 Unzip zipper on the top of the Headrest (as shown.)

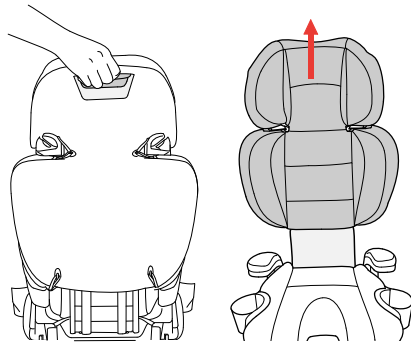

2 Squeeze the Height Adjustment Lever on the back of the Headrest and pull up to raise the Backrest.

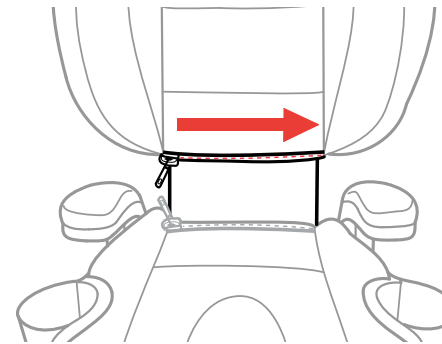

3 Unzip zipper on the Backrest (as shown.)

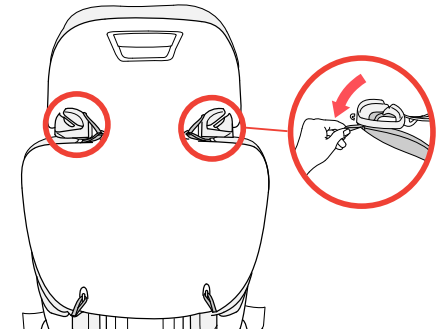

4 Unhook BOTH elastic straps on the back of the Backrest (as shown).

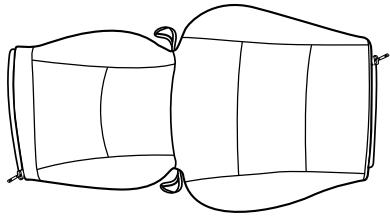

5 Remove the Back Pad from the Booster seat Backrest.

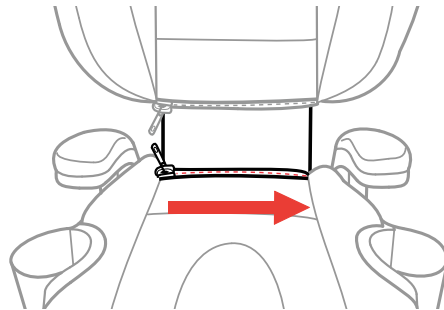

6 Unzip the zipper on back of the Booster seat bottom.

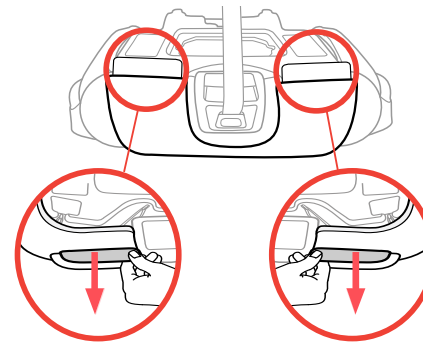

7 Flip the Booster seat bottom over and remove both Tabs on the front of the Booster seat.

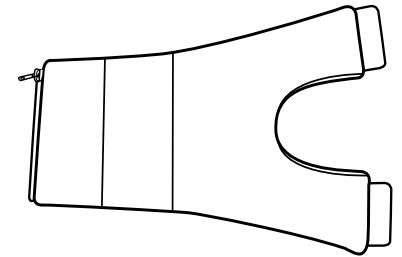

8 Remove the Bottom Pad from the Booster seat bottom.

KidFit Zip - Continue on STEP 8
KidFit Zip Air - Continue on STEP 9

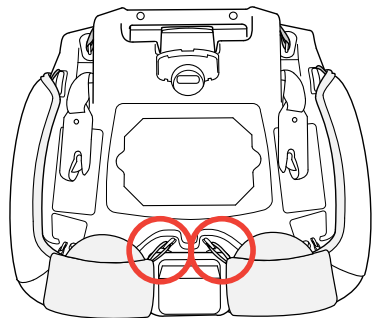

9 Flip the Booster seat bottom over and unhook 2 elastic loops on the front of the Booster seat.

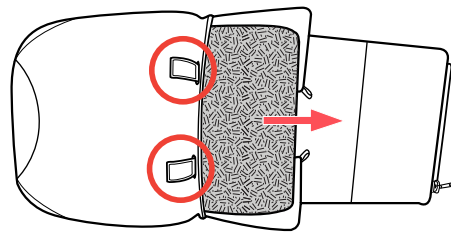

10 Remove Bottom Pad from the Booster seat bottom. Unhook both hook and loop straps on the Bottom Pad and remove Leg Rest Foam before washing.

TO REMOVE THE ARMREST COVERS:

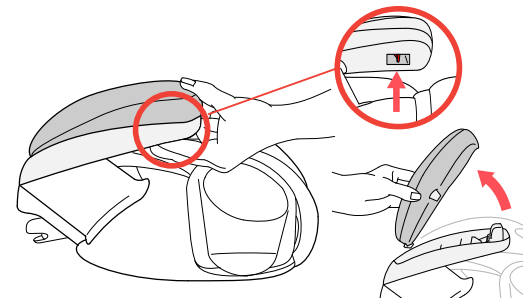

11 Locate the Armrest release button directly under the front of the Armrest. Pull on the button and at the same time lift up on the front edge to remove the Armrest cover.

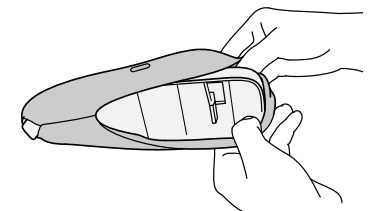

12 Pull back on the edges of the Armrest cover and slide the fabric off the Armrest base.

TO REMOVE THE FABRIC COVERS:

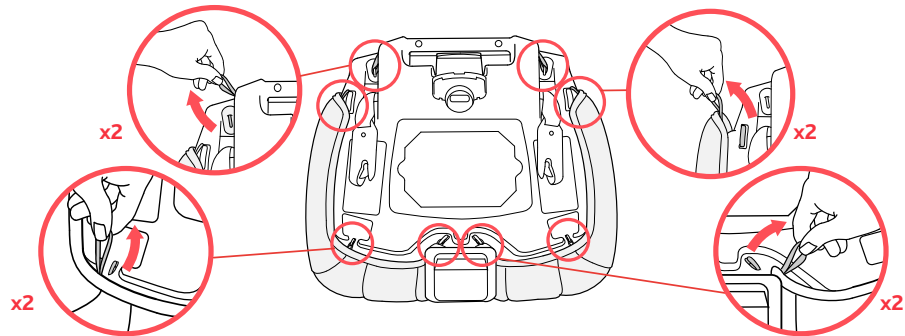

13 Flip the Booster Seat bottom over and unhook 8 elastic loops (as shown). Refer to User Guide to remove BOTH cup holders before continuing onto Step 14.

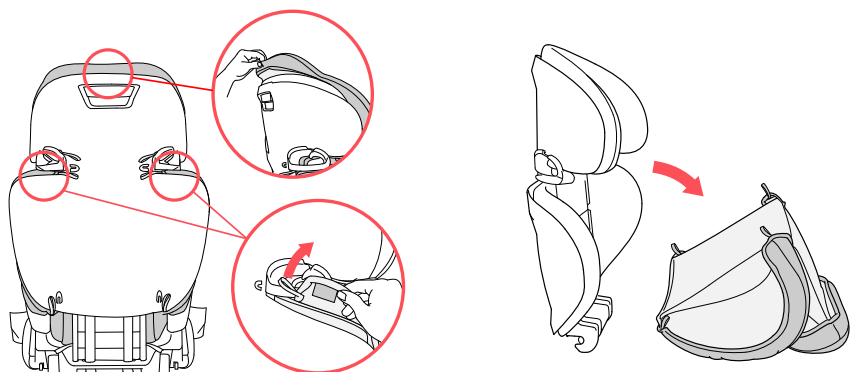

16 Lift up on the plastic tabs at the top of the Headrest and below the Shoulder Belt Guides, as shown.

17 Pull the Seat fabric cover forward to remove.

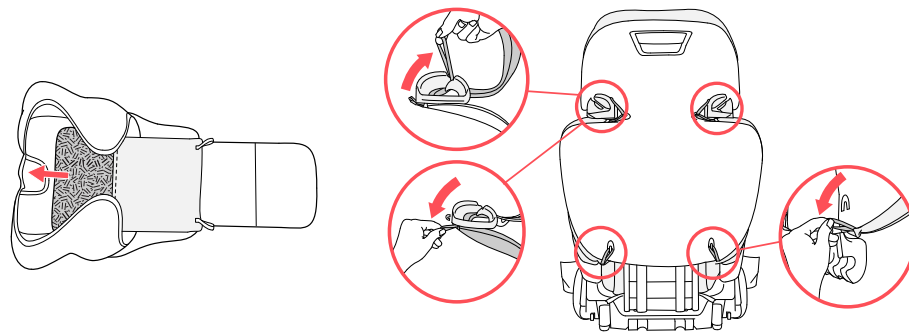

14 Remove the fabric cover from the Booster seat bottom. Flip the fabric over and remove the Foam Pad before you wash the fabric.

15 On the Booster Backrest, unhook 6 elastic loops as shown. Four behind the Headrest and two at the bottom of the seat back.

TO RE-ATTACH SOFTGOODS:

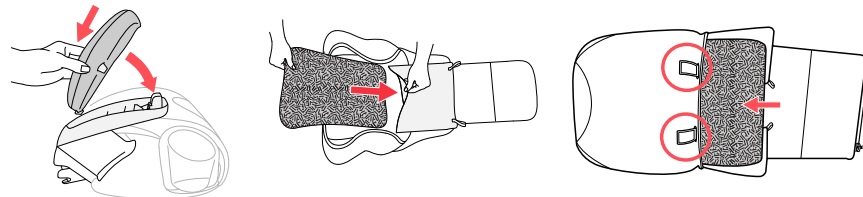

18 Re-attach Armrest covers refer to the USER GUIDE. Repeat steps 13 thru 17 in REVERSE to attach fabric covers. Make sure to insert Foam Pad into the seat bottom. Fit fabric carefully around all orange belt guides.

To re-attach Zip padding repeat steps 1 thru 8 in REVERSE.

To re-attach Zip Air padding repeat steps 10 thru 11 in REVERSE then 1 thru 6 in REVERSE. Make sure to insert the Foam Pad into the Bottom Pad.

The Booster Seat must never be used without the fabric covers. It may not perform as intended in the event of a crash.

Cleaning Instructions:

Fabrics may be spot-cleaned with mild soap and water, or machine washed in cold water on delicate cycle using mild detergent. Hang to dry. **DO NOT BLEACH.**

Please consult your product manual for additional care and maintenance instructions.

Contact Chicco Customer Service at 1-877-424-4226 for assistance in removing or replacing the softgoods.



WARNING: Avoid serious injury or death to your child. Never use your KidFit booster seat without the softgoods in place. You must read and understand the Softgood Removal instructions and the instructions in the User Guide. If you do not understand these instructions, DO NOT attempt to remove the Softgoods, STOP and call Chicco at 1-877-424-4226.

INSTRUCTIONS: KidFit Zip and Zip Air Softgood Removal

The KidFit Zip and KidFit Zip Air have four interchangeable pads (purchased separately). The Back Pad, the Bottom Pad and the two Armrest covers.

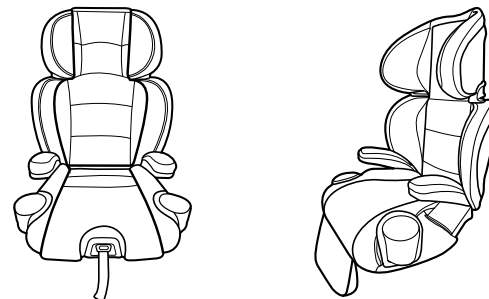

IMPORTANT: Please also refer to the instructions that came with your product.