

ELECTRIC STANDING DESK

Instruction Manual

ELT-Z4024

ELT-Z4824

ELT-Z5524

ELT-Z6324

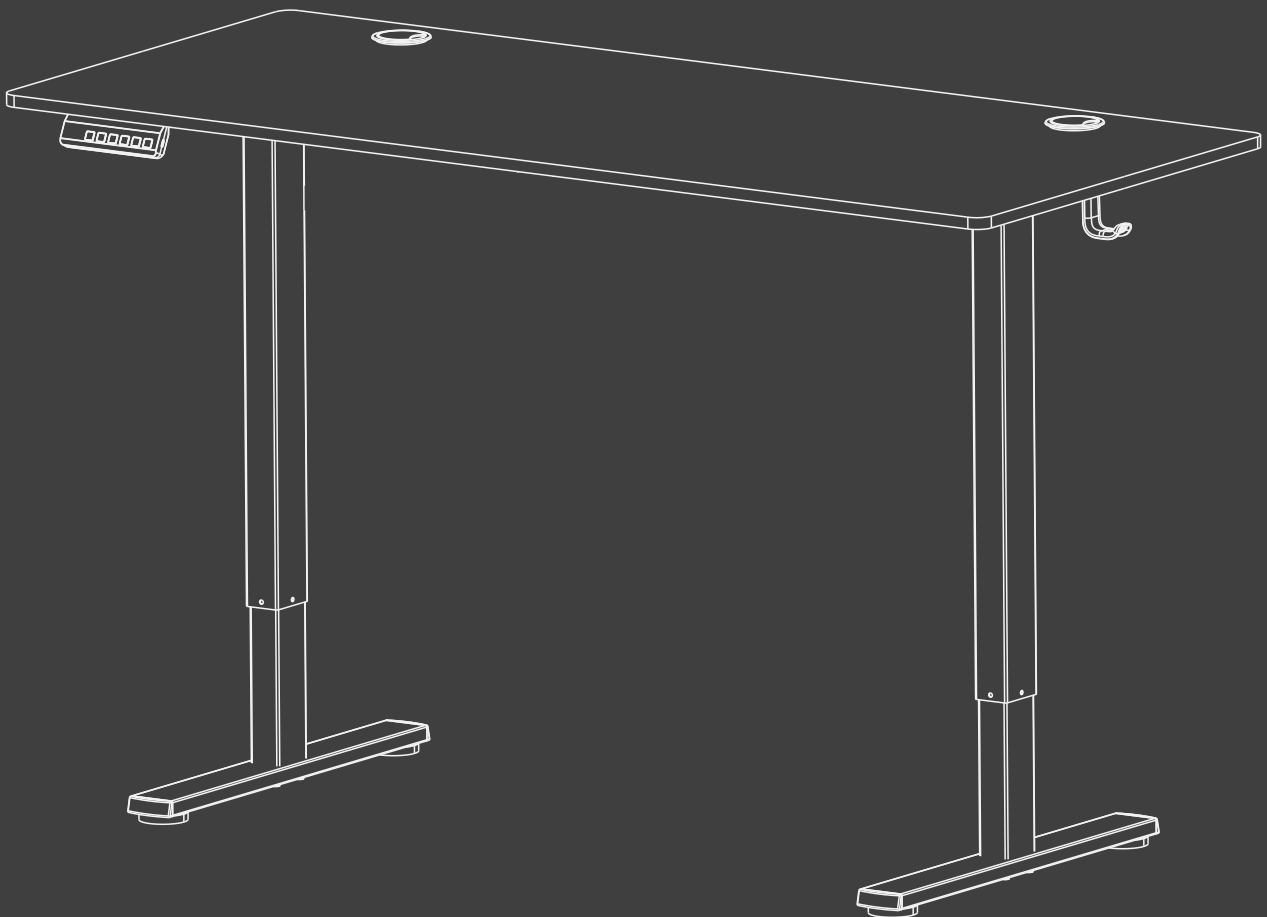

✉ HJ-Customer-Service@outlook.com

☎ (909)637-7665 | (909)637-7593

EST 9:00AM--17:00PM

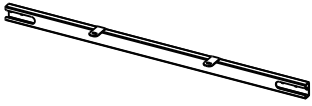

1 x1
Beam

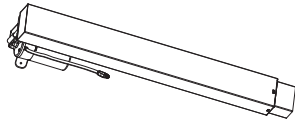

2 x1
Left Leg

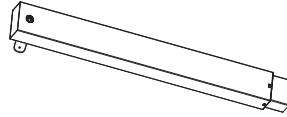

3 x1
Right Leg



4 x1
Drive Rod

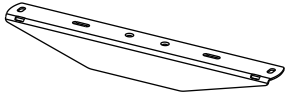

5 x2
Side Plate

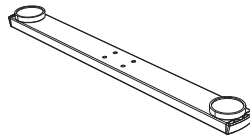

6 x2
Leg Base

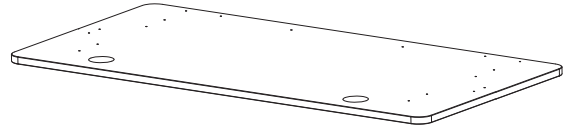

7 x1
Board

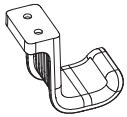

8 x2
Desk Connection Hook

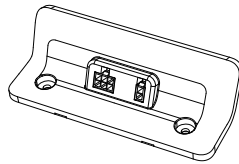

9 x1
Hand Controller

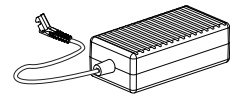

10 x1
Power Supply



11 x2
Cable Hole Cover

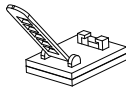

12 x2
Cable Clip



13 x10
Silicone Sheet

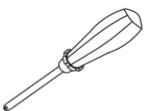

14 x1
Phillips screwdriver

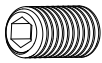

M-A x1

Screws
M5×10mm

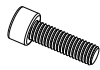

M-B x6

Screws
M6×12mm

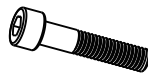

M-C x8

Screws
M6×35mm



M-D x6

Screws
M4×12mm



M-E x10

Screws
M4×16mm

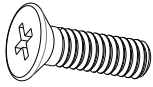

M-F x4

Screws
M6×16mm



2.5mm

M-G x1

Wrench



5mm

M-H x1

Wrench

Please read the installation instructions carefully before installatio.

Step 1

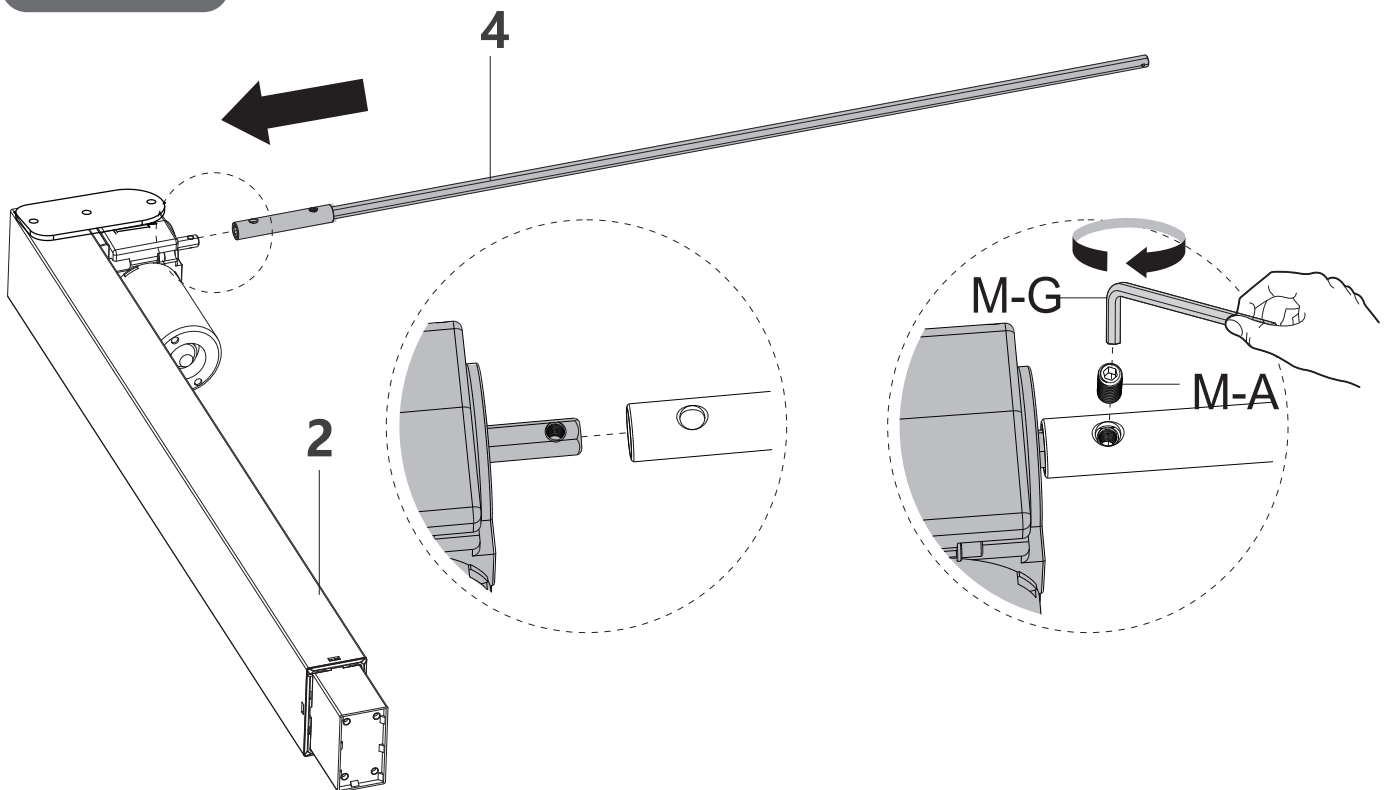

Align the holes of Left Leg (2) and Drive Rod (4), Using Wrench(M-G) to secure both with Screw (M-A).

Step 2

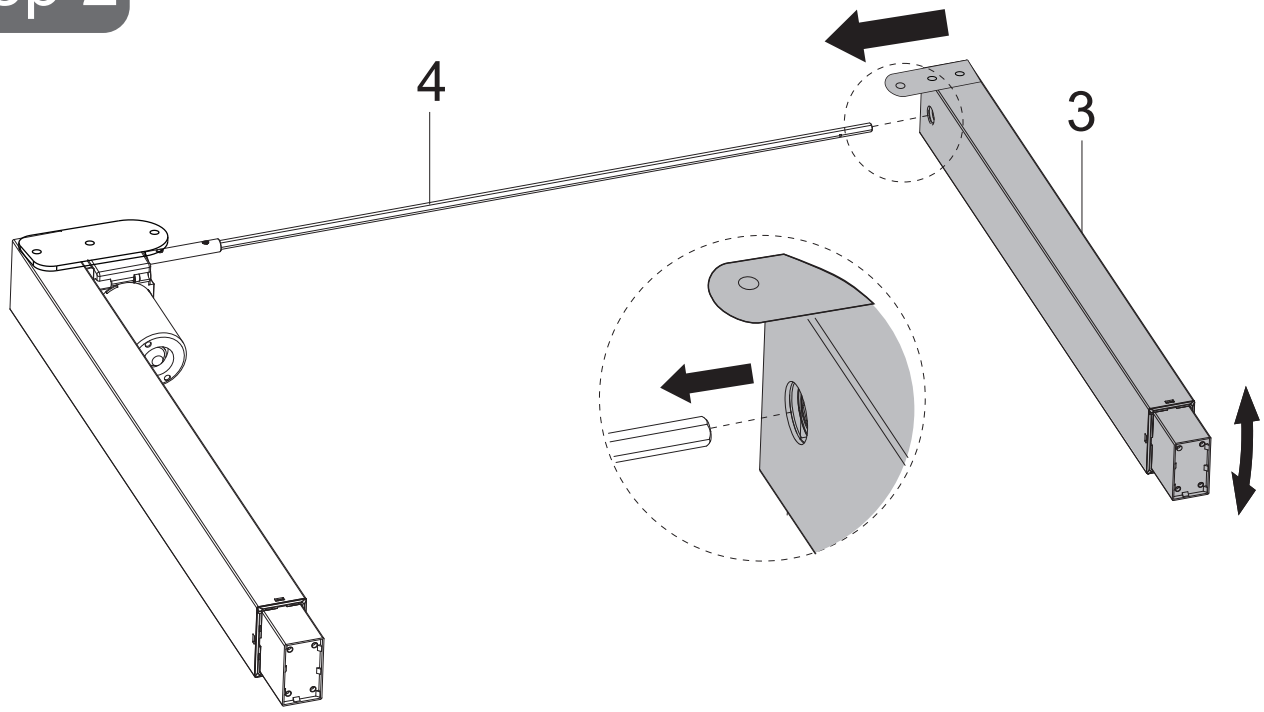

Insert the drive rod(4) into the hole in the right leg (3). If it is not possible to insert, please rotate the right leg (3) slightly until the inner hexagon matches.

Step 3

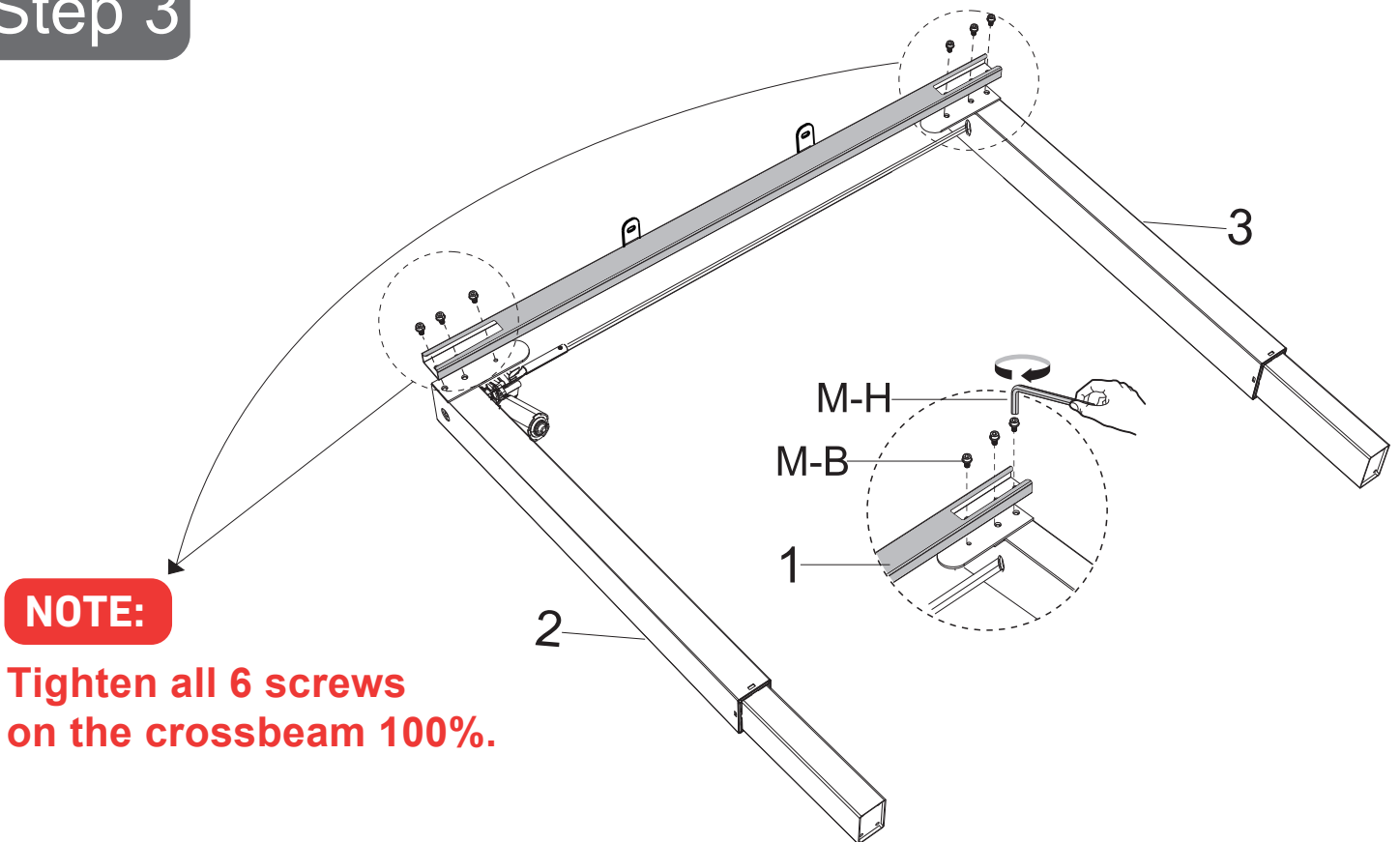

NOTE:
Tighten all 6 screws
on the crossbeam 100%.

As shown, use Wrench (M-H), install Beam (1) to the Legs (2&3) with Screws (M-B)*6.

Step 4

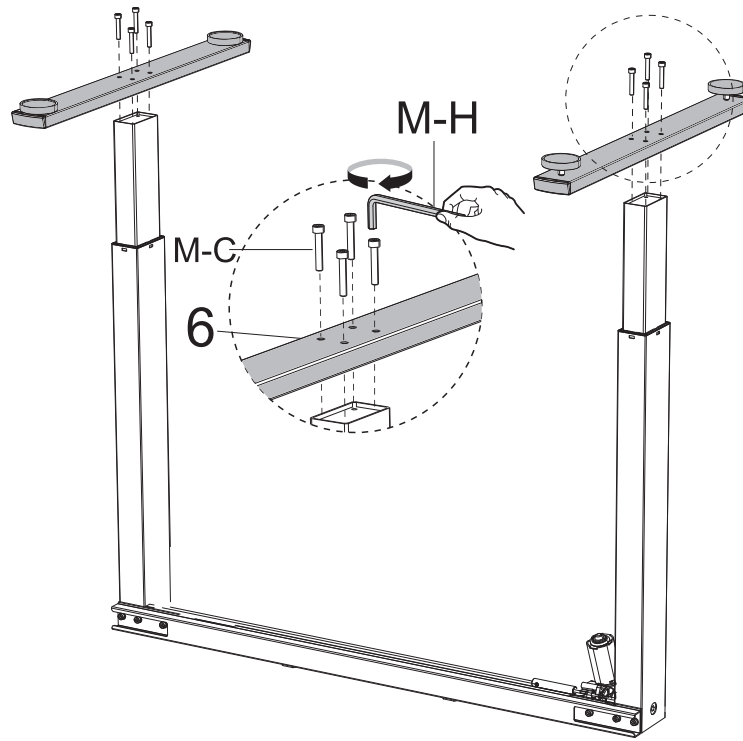

Using Wrench(M-H), install Leg Base (6)*2 to the Legs (2&3) respectively with Screws (M-C)*8.

Step 5

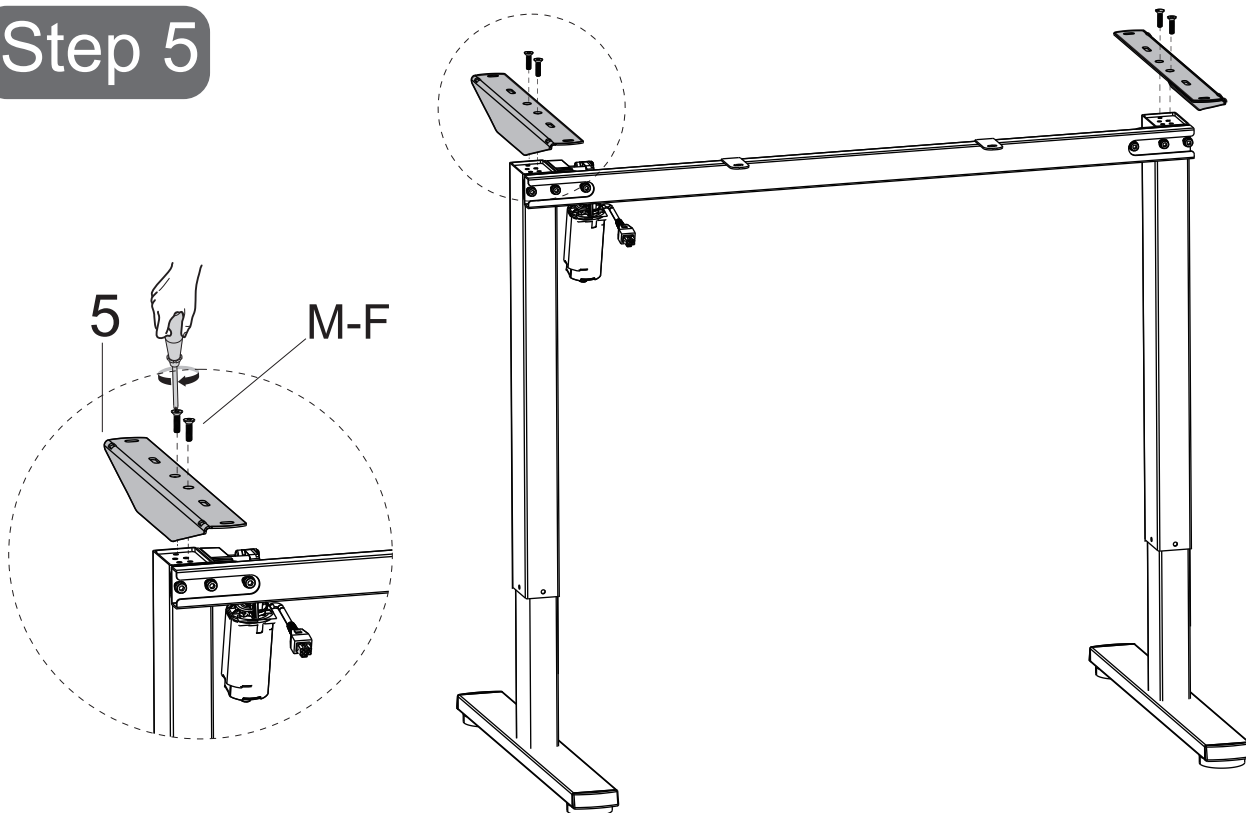

Use screwdriver , install Side Plate (5)*2 on each side of the Legs (2&3) with Screws (M-F)*4.

Step 6

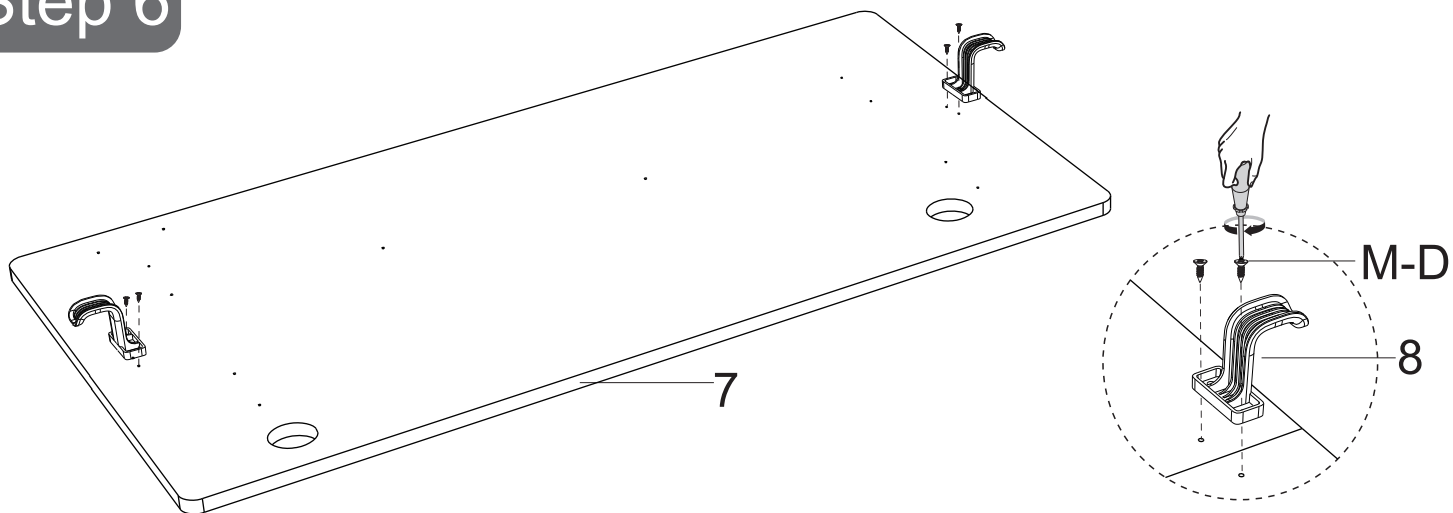

Use screwdriver with Screws (M-D)*4 , and Desk Connection Hook (8)
*2 to both sides of the Boards.

Step 7

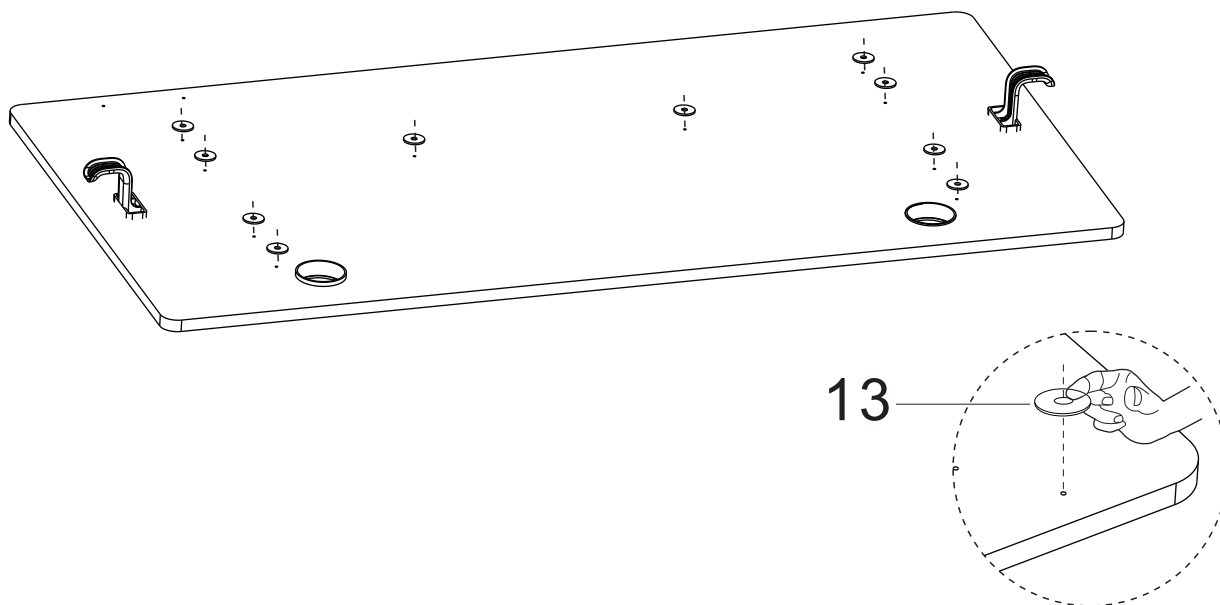

Fix Silicone Sheet (13)*10 to the corresponding hole position on the
Board.

Step 8

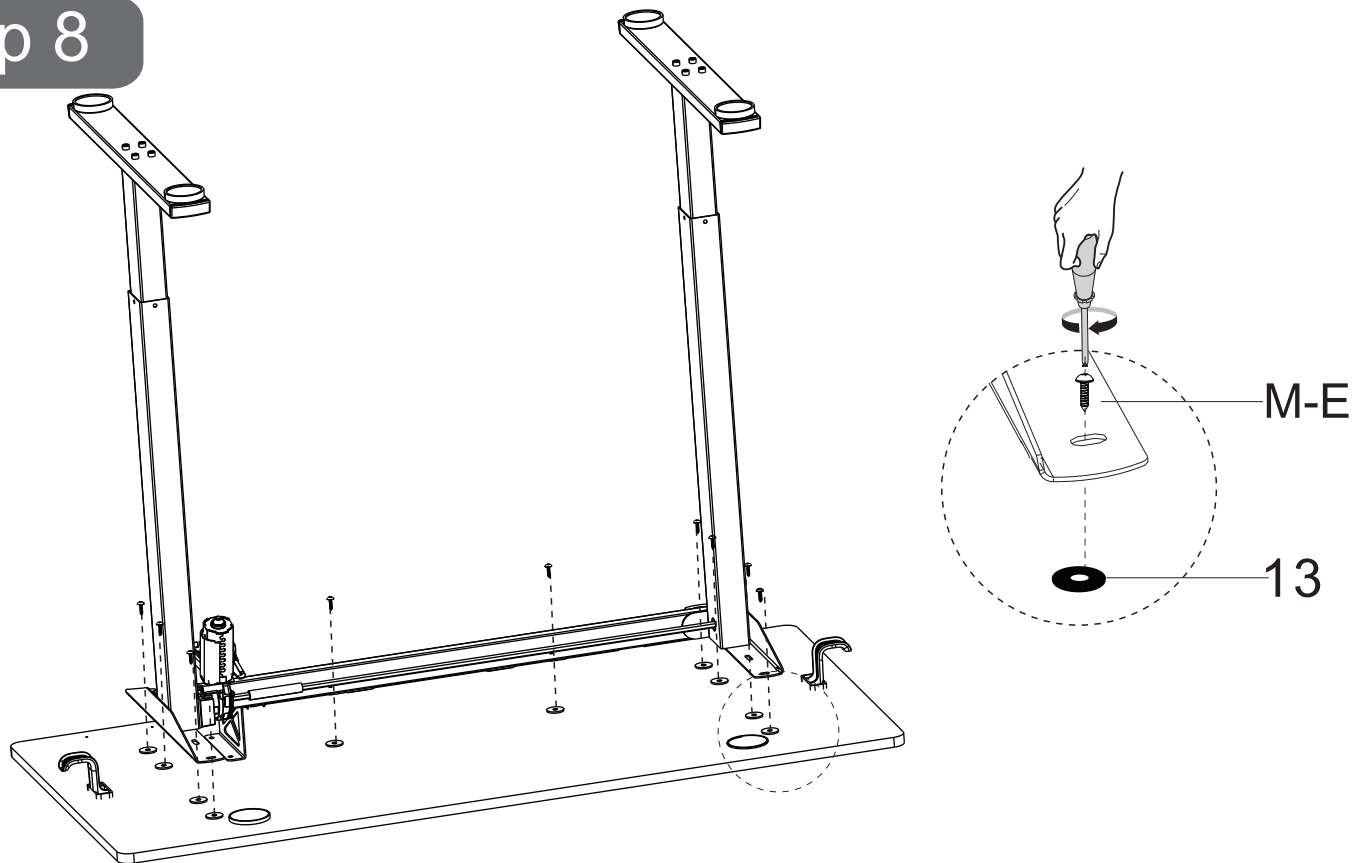

Use screwdriver, secure the Leg part to the Boards (7a&7b) with Screws (M-E)*10. Please align the Silicone Sheet (13)*10.

Step 9

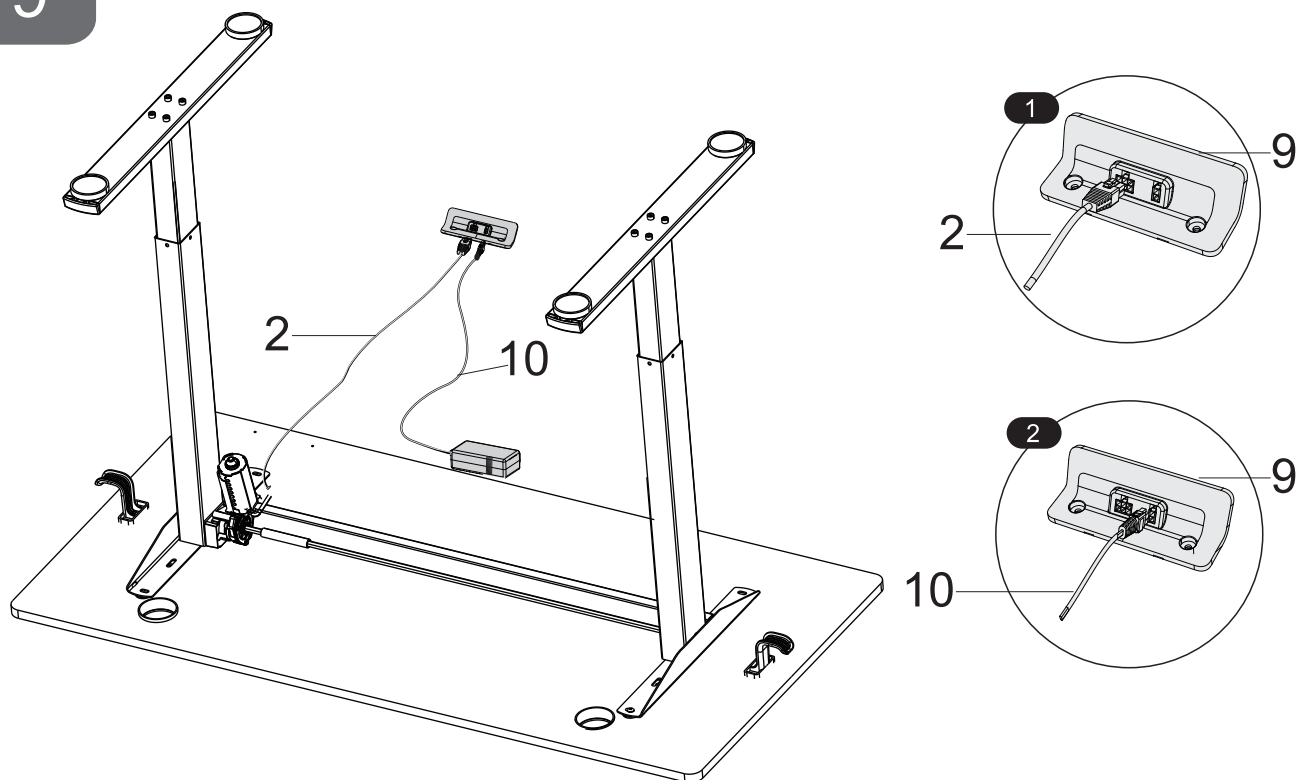

As shown, connect the motor at the Left Leg (2), Hand Controller (9) and Power Supply (10) in turn.

Step 10

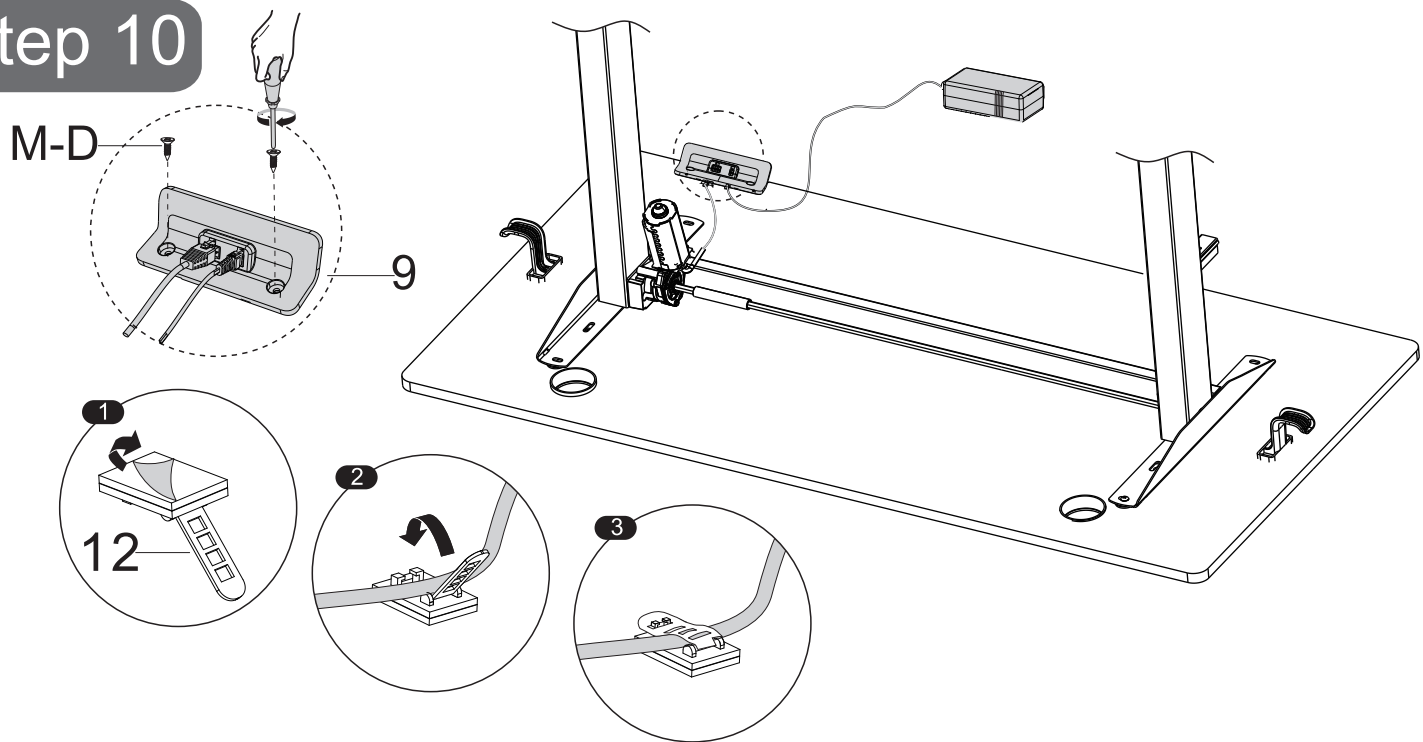

Using screwdriver install Hand Controller (9) to the Board (7) with Screws (M-D)*2. Secure the connecting cable with Cable Clip (12)*2 and glue it to the bottom of the Board.

Step 11

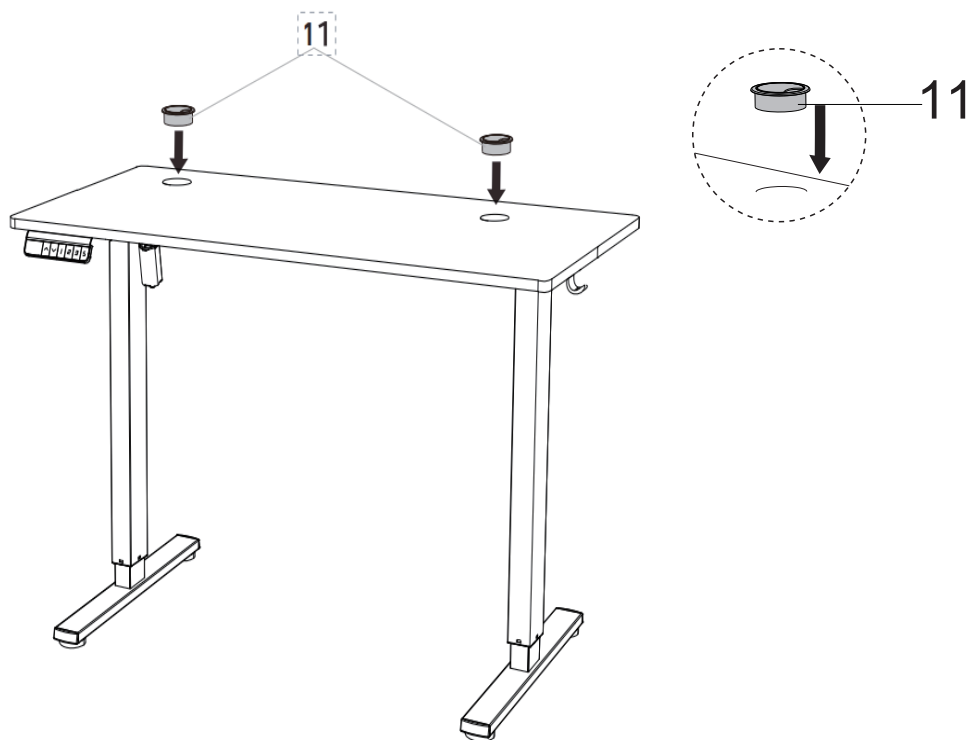

Insert Cable Hole Cover (11)*2 into the hole in the Board (7).

NOTE: Ensure that all bolts are 100% locked.

Using the Controller

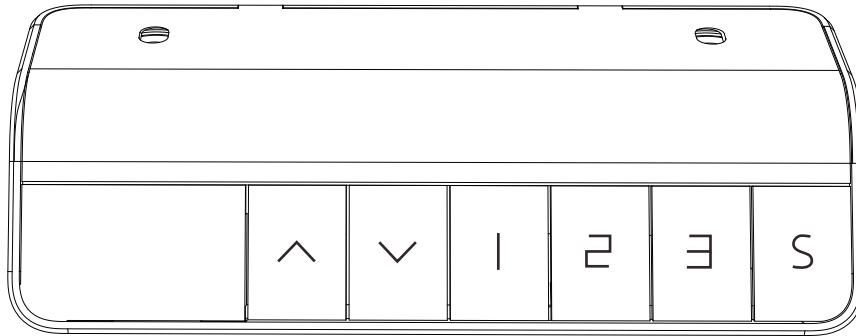

- **Raise the Desk**

Press the **^** button to raise the desk continuously until it reaches the highest position or the button is released.

- **Lower the Desk**

Press the **v** button to lower the desk continuously until it reaches the lowest position or the button is released.

- **Select Height Setting 1**

Press the **1** button, and the desk will move to the height that was previously set for that button.

- **Select Height Setting 2**

Press the **2** button, and the desk will move to the height that was previously set for that button.

- **Select Height Setting 3**

Press the **3** button, and the desk will move to the height that was previously set for that button.

Save Current Height Setting

Short-press the **S** button, and the screen will show 'S-'. Press the **1**, **2**, or **3** button to save the current height setting to that button. When you press the **1**, **2**, or **3** button, the desk will move to the height that was previously set for that button. Any button-press will stop the desk.

Settings

- **Reset**

Press and hold the \checkmark button until 'rst' is displayed. Continue holding until the desk goes down to its lowest level and comes back up slightly. Release the button, and reset is complete. If the button is released during the reset procedure, reset will stop. The desk won't work until reset is done correctly.

- **Child Lock**

Press and hold the \wedge and \checkmark buttons together for 5 seconds to turn child lock on. The screen will show 'LOC' and the buttons will be disabled. Turn child lock off the same way.

- **Settings Menu**

Press and hold the $\$$ button for 5 seconds to enter the settings menu. Short-press the $\$$ button to navigate through the menu. Short-press the \wedge or \checkmark button to adjust the settings. Long-press the \wedge or \checkmark button to quickly adjust the height settings. Press and hold the $\$$ button again to save the changes. 'SUS' will be displayed if saving is successful (or 'FAL' if saving fails). If there is no button-press for 10 seconds, the settings menu will be exited automatically.

- **Power-Saving Mode**

The screen will turn off if there is no button-press for a minute. Any button-press will turn the screen on again.

Protection Mode Error Codes

SC0	Standby Overvoltage Protection: Standby voltage too high. Power o the desk, check the connection between power and the controller, and power on again. If error code persists, please contact technical support.
SC1	Power Supply Overvoltage Protection: Input voltage too high. If the correct AC adapter is being used, power o the desk, check the connection between power and the controller, and power on again. If error code persists, please contact technical support.
SC4	Operating Overvoltage Protection: Operating voltage too high. Power o the desk, check the connection between power and the controller, and power on again. If error code persists, please contact technical support.
hot	Overheating Protection: When the motor has been working continuously for too long, it will stop operating to prevent overheating. Wait for at least 18 minutes (until error code disappears) before making any further height adjustment.
r-6	Power Supply Overvoltage Protection (during use): Input voltage too high. Error clears when power supply voltage returns to normal. If error code persists, please contact technical support.
rst	Reset Warning: Continue to complete reset.
E10	Short Circuit Protection: Power o, check the cable connections, and power back on again. If error persists, please contact technical support.

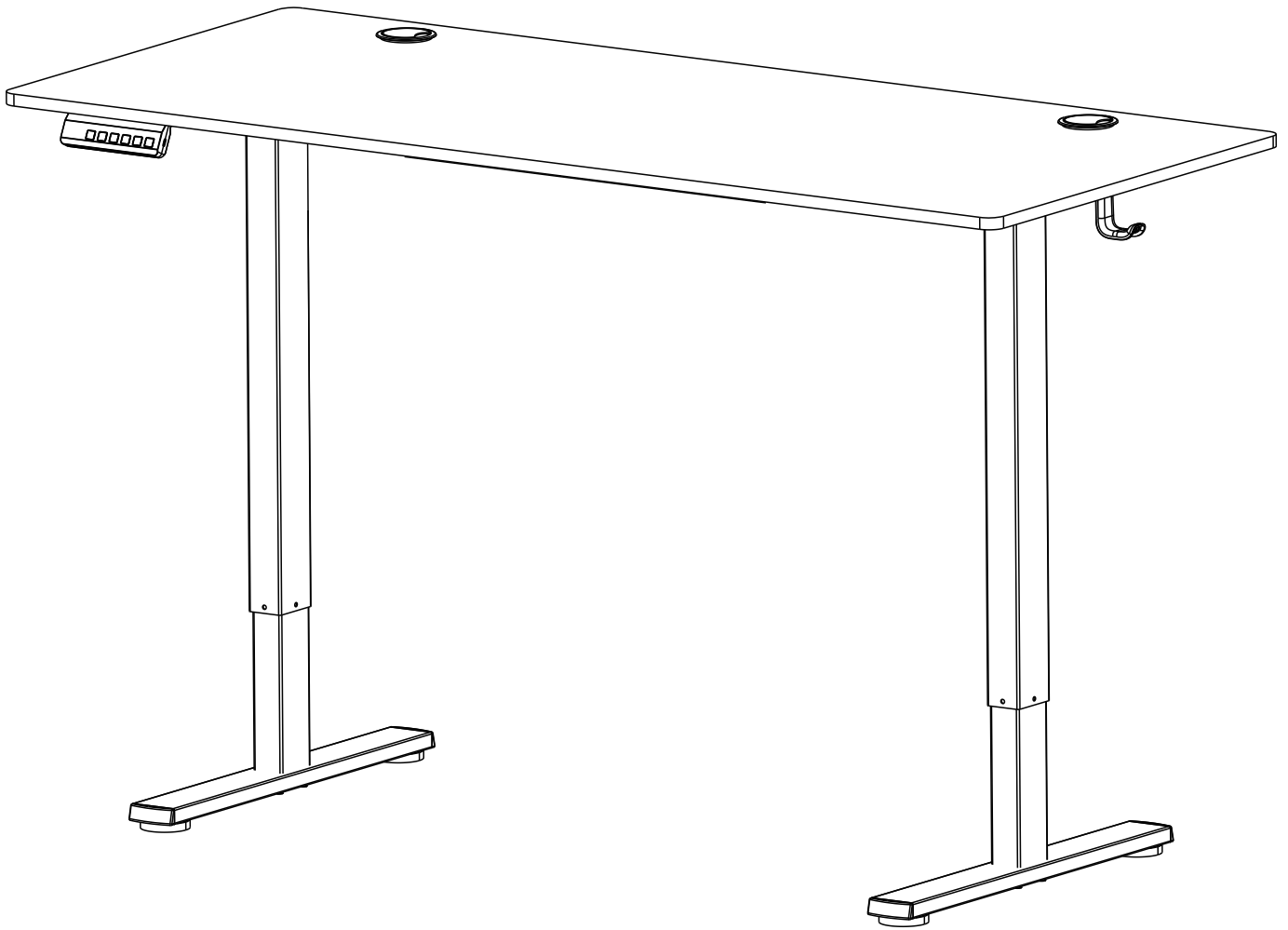

Technical Support

(909)637-7665 | (909)637-7593

Other Info

HJ-Customer-Service@outlook.com

Thank you for choosing this product. We strive to provide you with the best quality products and service in the industry. Should you have any issues, please don't hesitate to contact us.