



## **BN101-GS Series**

---

BN101-GS handheld cleaning head (single galvo)- User Manual

**Document History**

<b>Edit date</b>	<b>Version</b>	<b>Topic, revision, action taken</b>
2023/1/10	V1.0	First edition
2023/2/21	V1.1	Configuration update

Thank you for choosing our product!

This manual describes the installation and commissioning of laser cleaning head in details so that you can use this product quickly. You can consult us directly for more details.

Due to the continuous updating of product functions, the product you receive may differ from the introduction in this manual in some aspects.

We reserve all rights in this document including the issued patents and other registered commercial ownership related to this document. It is strictly prohibited to use this document in an improper way especially to copy and disseminate it to third parties.

If you find any errors in this document, please inform us as soon as possible. The data contained in this manual is only used to describe the product and shall not be regarded as a statement of security interest.

For the benefit of our customers, we will constantly try to ensure that the products we develop comply with the latest technology.

**Raytools AG**

Email: [sales@raytools.com](mailto:sales@raytools.com)

Website: [www.raytools.ch](http://www.raytools.ch)

### **Disclaimer**

- We reserve the right to change the design in order to improve the quality or expand the application or comply to manufacturing workmanship.
- We will not bear any responsibility for losses and accidents caused by wrong operation or improper handling of our products.
- Dismantling of product will lose all warranty claims excluding the normal replacement of worn parts and components required for maintenance or commissioning operations.
- Unauthorized modification of products or use of non-original spare parts will directly lead to the invalidation of warranty and liability exemption.
- It is recommended to only use the spare parts provided by us or submit them to us or the designated professional team for installation.

### **Use Regulations**



- Ensure that the product is used in a dry environment.
- Ensure that the product is used in the environment required by EMC standards.
- The product is only allowed to run within the parameters specified in the technical data.

### **Personnel Responsibilities**

- Be familiar with the basic provisions of work safety & accident prevention and have received equipment operation guidance.
- Read and understand basic safety instructions and operations.
- You must have studied the relevant regulations and safety instructions and understand the possible hazards.
- Comply with relevant regulations and implement corresponding protective measures.

## Safety Instructions

### Prevent Electric Shock

-  Parts of the laser head such as nozzle, sensor, sensor interface and attached fasteners may not be fully protected by the ground wire due to function fault. These parts may have low voltage. When installing electrical equipment, please pay attention to taking anti electric shock measures for relevant personnel.
-  Note that the equipment shall be grounded as specified.

### Guard against Danger

- Never put your hands or other body under the laser head.
- Repair and maintenance work can only be carried out after the power is turned off.
- Do not exceed the specified maximum pressure.
- It must be ensured that the laser head is in normal condition at all times.
- All fasteners such as bolts and nuts must be tightened.



### Laser Caution

- Avoid direct laser radiation or scattering to the skin.
- Do not stare at the laser beam even when wearing optical equipment.
- Use special laser protective eyeglasses that meet the requirements of safety standards IEC 60825-1.

### Prevent Waterway Corrosion

- In order to avoid corrosion, use the specified coolant and comply with relevant requirements and specified maintenance intervals.

### Noise Prevention

- The corresponding measures shall be specified or explained and observed in order to prevent personnel from being harmed by noise when the cutting air pressure is high.

### Storage and Transportation

- Observe the storage temperature range allowed by the technical data.
- Take reasonable measures to prevent fire, vibration or impact.
- Do not store in or near the magnetic field.

## Contents

1	Preface .....	1
1.1	Company Introduction .....	1
2	Safety Instructions & Precaution .....	2
2.1	Summary.....	2
2.2	Operation Standards.....	2
2.3	Warning signs and instructions.....	2
2.4	Damage Source .....	3
2.5	User Guideline .....	4
3	Handheld Cleaning Head .....	7
3.1	The Connection of QBH Interface and Handheld Cleaning Head .....	7
3.2	Removal and Installation of Cover Glass.....	8
3.3	Inspection .....	9
3.4	Safety Shutter .....	9
4	Controller .....	10
4.1	Connection of HMI Panel Communication Wire and Controller .....	11
4.2	Connection of Laser and Controller .....	11
4.3	Connection of Handheld Cleaning Head and Controller .....	12
4.4	Connection of Power Supply and Controller Box .....	12
4.5	Connection of Gas Valve, Chiller and Controller.....	13
5	Software Introduction.....	14
5.1	Main Interface Description .....	14
5.2	Setting.....	16
5.3	Process Library.....	17
5.4	Monitoring.....	18
	Schedule 4: Wiring Diagram between Controller and Fiber Laser .....	19
1、	BWT Laser DB25.....	19
3、	Maxphotonics Laser Aviation Plug- 12PIN Interface.....	21
4、	Raycus 380/220V DB25 PIN .....	22
5、	JPT Fiber Laser 24PIN .....	24
6、	IPG YLR-Y14.....	25
7、	Feibo Laser .....	26

## 1 Preface

### 1.1 Company Introduction

Founded in 2009, Shanghai Empower Technologies Co.,Ltd. is a high-tech enterprise in the laser manufacturing industry. With over ten years of technology development and innovation, we strive for "xEOS Empower Laser Smart ABC", (AheadTechs CNC, BeamTools Smart Laser Head, and CloudAhead Cloud Service), providing professional and one-stop solutions for integrators and customers.



Figure 1.1

- Wide business field  
More than 5,000 products including nozzles, lens and even laser solutions, and about 100 laser heads, meeting application requirements in the laser market.
- Large customer group  
About 2000 customers in 30 areas in China and more than 100 overseas customers including in Russia, South Korea, India, Argentina and Ukraine.
- Strong technical strength  
More than 400 employees, with 50% in technical R&D and engineering sections, acquiring more than 150 patents and copyrights.
- Fast service response  
Several after-sales service points covering Shenzhen, Wuhan, Jinan, giving real-time and quick feedback.

## 2 Safety Instructions & Precaution

### 2.1 Summary

This chapter summarizes all the information to operate laser equipment safely. Laser radiation could heat objects and cause hazard to eyes and skin. Therefore, to avoid potential risks, please operate this equipment correctly as required and take protections.

Please place this manual near laser equipment.

### 2.2 Operation Standards

Operation standard for handheld cleaning head - single-galvo:

GB 7247.1-2012 Safe operation of laser product-Part 1: Equipment classification & requirements

### 2.3 Warning signs and instructions

Warning signs including:

Information about the name and hazard source;

Information about the possible consequences if the danger has already occurred;

Information about signs to avoid damage.

Serious consequences may be caused by violating signs such as "Danger", "Warning", "Caution", and "Note".

"Danger": Serious danger with death or severe injury possibly;

"Warning": Moderate disability and permanent injury possibly;

"Caution": Mild disability but not permanent injury possibly;

"Note": Material damage possibly;

"Remark": Explanation and description for operation.

Warning eg. :

	Warning
<p>If the laser radiation doesn't deviate from the human body, eyes and skin may be exposed. Laser radiation will burn the skin, and direct and scattered laser beams will cause permanent eye damage.</p>	

## 2.4 Damage Source

Laser products are manufactured in accordance with the newest standard and accepted safety rules. However, there are risks to people and materials in operating, which will cause possible hazard and loss if failed to observe these rules.

This section explains the possible danger caused by laser products and response measure including:

How to reduce risks through measures Raytools provides;

How to ensure the safety of users when operating laser equipment through effective measures.

### 2.4.1 Laser beam

Laser beams may hurt eyes and skin. This product is classified as the Class 4 according to different damage definition. Therefore, please wear protective eyeglasses when cleaning and beaming out. Otherwise, we will not bear any responsibility for loss caused by violating rules.

Laser products is classified by safety standards EN 60825-1 and IEC 60825.

Class 4: By definition, a Class 4 laser can burn the skin, or cause devastating and permanent eye damage as a result of direct, diffuse or indirect beam viewing. These lasers may ignite combustible materials, and thus may represent an explosion risk.

Please wear laser protective eyeglasses when operating, and avoid direct laser radiation or scattering to the skin.

### 2.4.2 Gas & smoke & dust

Harmful gases, smoke and dust may be produced when processing workpiece. These materials may enter the respiratory tract and cause injury to nose or eyes, if contacting with the skin and mucous membranes in the mouth.

Submicron dust particle: Solid matter less than 1 micron in diameter

Smoke: Gas containing solid and liquid particles less than 1 micron in diameter.

Workpiece materials and divergent substances is closely related to cancer.

Carcinogens: Beryllium and zinc chromate, etc.

Relevant factors: Material type, producing speed, laser energy and protective gas pressure.



### 2.4.3 Thermal energy

Fire & Explosion: A Class 3B or Class 4 laser beam may ignite combustible materials, and thus may cause fire. Although laser beam does not directly irradiate solid materials with high energy, it's possible to cause fire by explosive gases or smoke in the air (such as hydrogen-oxygen mixture, sawdust and carbon chips).

■ Workpiece temperature: The laser beam will lead to a rising temperature of workpiece in operating, which depends on the workpiece material and laser beam energy.

	Warning
Touching hot workpieces may cause burns	

Solution:

Use appropriate tools and wear protective gloves to move hot workpieces, and don't touch the surface directly.

### 2.4.4 Noise

Noise will be generated when using handheld cleaning head to beam out and blow protective gas.

These noise may come from material gasification due to exposure to laser beam, but the max noise source is compressed protective gas [ $>60\text{dB(A)}$ ], which are applied to protect cover glasses through annular air knife when cleaning.

	Warning
There is noise to operate handheld cleaning head.	
Noise may cause permanent hearing damage and other health problems, especially when exposed to it for a long time.	

Solution:

Mount protective cover for effective noise reduction; Earmuff is available at high noise level.

## 2.5 User Guideline

### 2.5.1 Using rule

Handheld cleaning heads are mainly designed to clean the surface of substrate without contact.

Including:

1. Follow the instructions in this manual.
2. Follow laser usage rule, connecting fiber interface and cleaning head safely and scientifically.
3. Follow the electromagnetic coordination rule, wiring to the handheld cleaning head.
4. Inspect and maintain cleaning head.

Not allowable operations:

1. Operating laser with unspecified wavelength, or with laser power > 2kW.
2. Cleaning containers with flammable and explosive substances (including combustible gas, petrol and explosive).
3. Operating in a gas environment with explosive risk.

Laser manufactures will not bear any responsibility for loss caused by violating the using rules.

### 2.5.2 Technical guideline

■ Laser product state

Laser products can only be used in good condition. Any damage should be repaired timely, especially those problems affecting safety facilities.

■ Modify

Don't modify any parts without the permission of Raytools, to avoid unsafe usage of laser product.

■ Spare parts

Spare parts must meet technical requirements of Raytools.

■ Software

Don't modify software.

■ Connecting wire

Laser fiber and circuit cables should be placed well, following the minimum bending radius of fiber. And the connecting wire should be away from transportation channels and machine parts with frequent and severe vibration.

### 2.5.3 Follow standards and rules

Please comply with the following important rules when operating laser (for reference).

Operators should ensure to comply with these mandatory standards and regulations.

As shown in Figure 1.1, International Standard:

IEC60825	Radiation of laser product
EN60825	Safety of laser product
EN207	Personal eye-protection equipment—Filters and eye-protectors against laser radiation.
EN60204	Electrical equipment of machines

Figure 1.1

### Maintenance

1. Close all water/gas/ electrical circuit and safety shutter before maintaining and check in the clean environment.
2. Commission and maintain laser products regularly according to the manual. Please refer to the following chapters for maintaining detail and replace parts as required.
3. Check whether devices testing laser product are in good working regularly.

#### 2.5.4 Emergency & Safety Measure

Emergency including:

1. Laser leakage.
2. Movement caused by uncontrolled system components.
3. Fire or explosion.
4. Leakage of harmful substance.

Safety measure:

1. If there are any other situations will affect human health or damage materials, please solve them timely.
2. If the danger is caused by laser products, press the emergency "Stop" button to stop radiating laser and running machine.
3. Other specific measures should be taken for different situation.
4. We recommend that users of laser products should identify potential risks through assessment and then take corresponding measures, to minimize losses or give emergency treatment to the injured.
5. Please prepare emergency signs in visible places where there is potential risk.

### 3 Handheld Cleaning Head

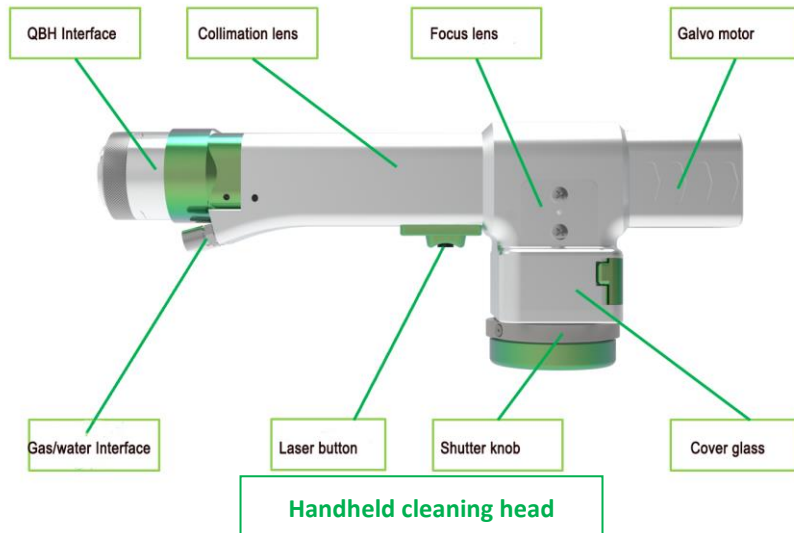

Figure 3.1

#### 3.1 The Connection of QBH Interface and Handheld Cleaning Head

1、As shown in Figure 3.2.

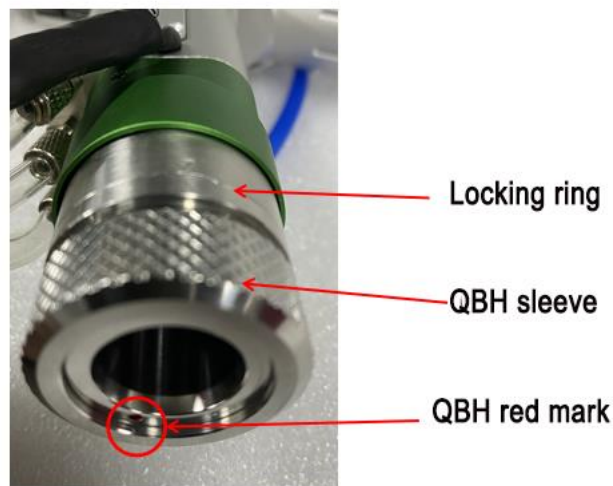

Figure 3.2

2、 Remove fiber dustproof cover and check whether the protective cap for fiber crystal head is locked. Clean the fiber head with dust-free cotton swabs and absolute ethanol until it's dust-free. As shown in Figure 3.3.

### Fiber output head (QBH)



Figure 3.3

3、 Place the welding head horizontally, align the red mark of male fiber end to red mark on female QBH of cleaning head when you insert the fiber end straightly to bottom of QBH interface of cleaning head.

4、 QBH Fiber Insertion: Take out the sealed transparent protective cover (Figure 3.4), rotate the steel cover counterclockwise (Figure 3.5), adjust the indicator ring to "Unlock" state. After inserting the fiber head, adjust the locking indicator ring to "Lock" state (Figure 3.6), and then turn clockwise to end. (Figure 3.7). Steel cover state is shown as below



Figure 3.4



Figure 3.5



Figure 3.6



Figure 3.7

## 3.2 Removal and Installation of Cover Glass

1. Loosen the buckle to open the cover glass drawer cover, pull out the drawer and place the cover back to avoid dust in, as shown in figure 3.10.

2. Remove the seal ring and cover glass for cleaning or replacement, as shown in Figure 3.10.

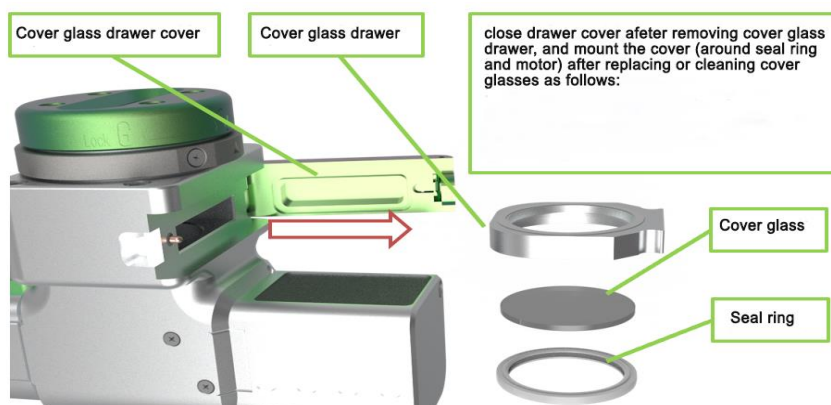

Figure 3.10

### 3.3 Inspection

1. Check whether cover glasses are contaminated before using every day. If so, replace them.
2. Check whether the QBH interface is loose before using every day. If so, tighten it.
3. Check whether connecting wire contains water before using every day; If so, clean and check if there is water seepage.
4. Please ensure that water and gas interfaces are connected correctly (assist gas in middle, water in/out on both sides).

Gas/water cooling interface:  $\phi$  6mm

As shown in Figure 3.12.



Figure 3.12

### 3.4 Safety Shutter

The safety shutter is equipped with an in-pos signal. Please open the shutter before beaming out, and close it immediately after processing to prevent loss or dust into the laser exit to contaminate the lenses.

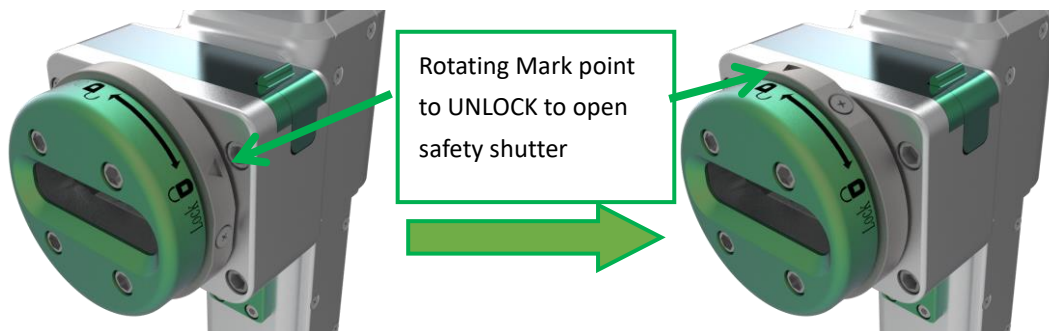

## 4 Controller

Controller overview of handheld cleaning system

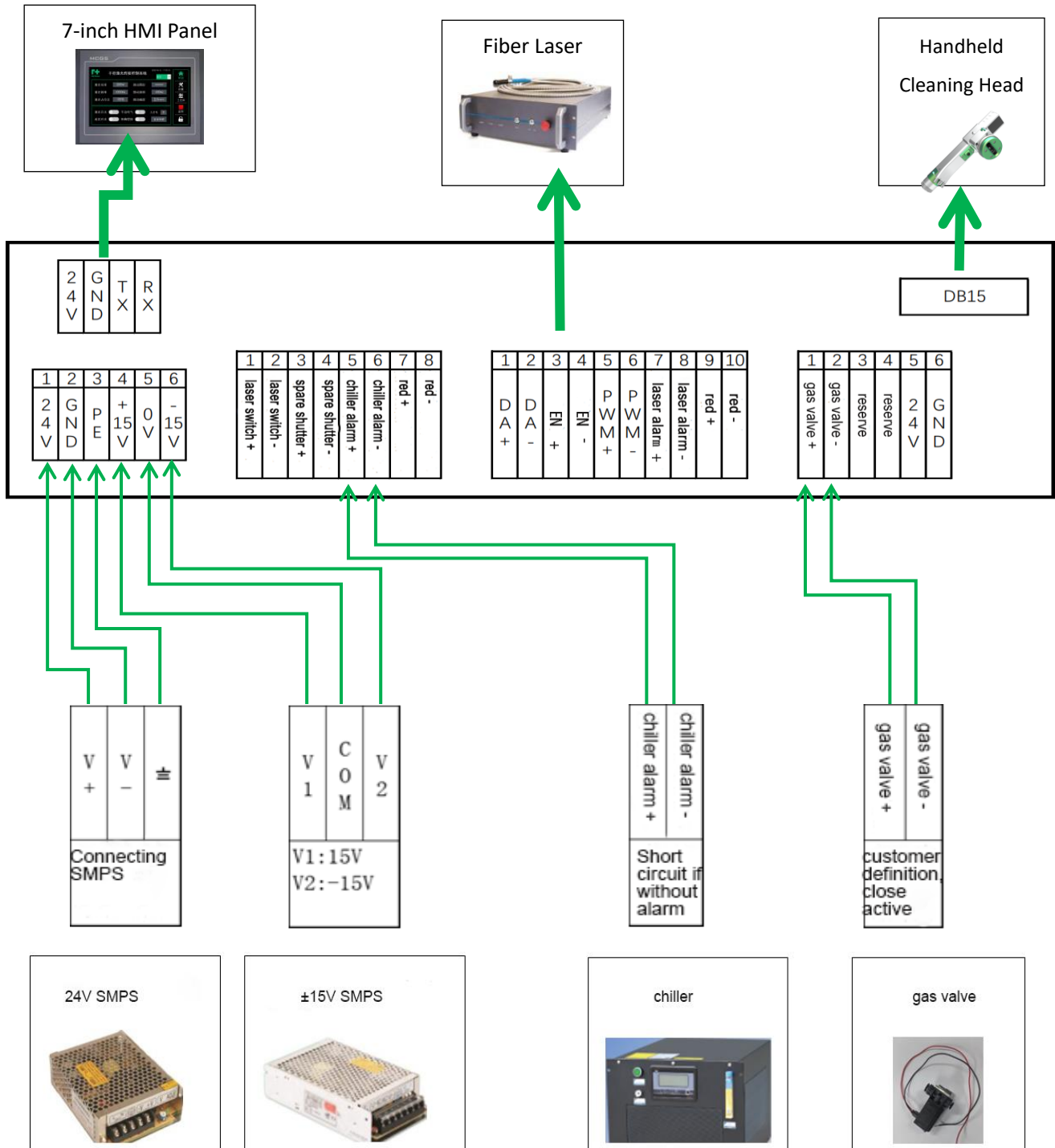

## 4.1 Connection of HMI Panel Communication Wire and Controller

As shown below.



HMI panel communication wire



Wiring method

## 4.2 Connection of Laser and Controller

Connect the control box with Enable $\pm$ , PWM $\pm$  and DA $\pm$  of the laser (Laser Fault is not required). However, different lasers require different wiring methods, and some lasers need to be interlocked before beaming out.

As shown in Figure 4.4.

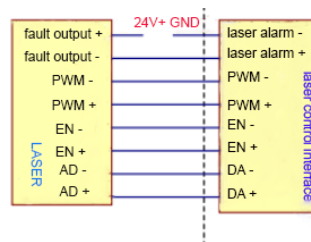

Figure 4.4

Enable $\pm$ : Enable +, laser enable output signal +; Enable -, laser enable output signal ground. (Enable input, generally NPN active)

PWM $\pm$ : PWM+, modulation output signal +; PWM-, modulation output signal ground. (control laser modulation beaming)

DA $\pm$ : DA+, analog output +; DA-, analog output ground. (control laser beaming power)

Fault $\pm$ : Fault +, fault signal output +; Fault-, fault signal output -. (controller receiving laser alarm signal)

For different wiring methods, please refer to Schedule 4: Wiring Diagram between Controller and Fiber Laser. Schedule 4 do not include all wiring methods for lasers, and these diagrams are for reference only.

If there is any discrepancy, please operate laser base on the instructions provided by manufacturers.



### 4.3 Connection of Handheld Cleaning Head and Controller



Figure 4.5

DB15 interface on the cleaning head wire connecting DB15 interface of control box, as shown in Figure 4.5.

### 4.4 Connection of Power Supply and Controller Box



24V



±15V



图 4.6

As shown in Figure 4.6:

±15V Power: V1 to 15V+, V2 to 15-, and com to GND.

24V Power: V+ to 24V+, and V- to GND.

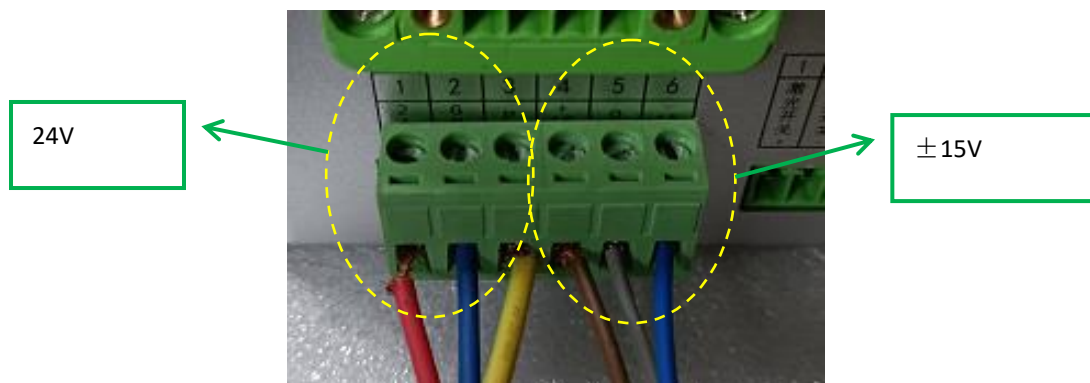
## 4.5 Connection of Gas Valve, Chiller and Controller

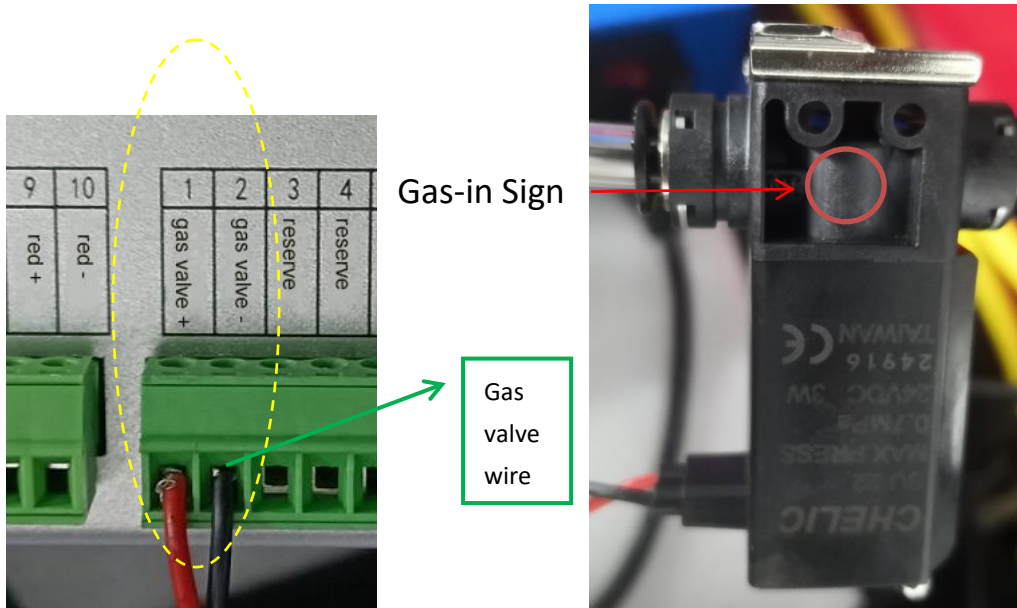
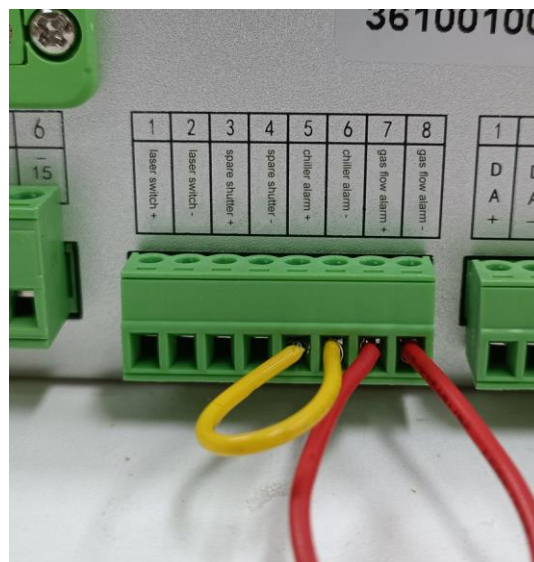

Figure 4.7

**Gas valve ±:** Switch for protective gas control. Valve +, 24V + relay output, no need for additional relay control; Valve - is 0V, and customized solenoid valves have different inlet and outlet. Please confirm interfaces are connected correctly.

**Chiller alarm ±:** Switch signal. If without chiller alarm interface, water pressure allows positive and negative short circuit.

**Gas flow alarm ±:** Switch signal, if without gas flow alarm valve, gas flow allows positive and negative short circuit.



## 5 Software Introduction

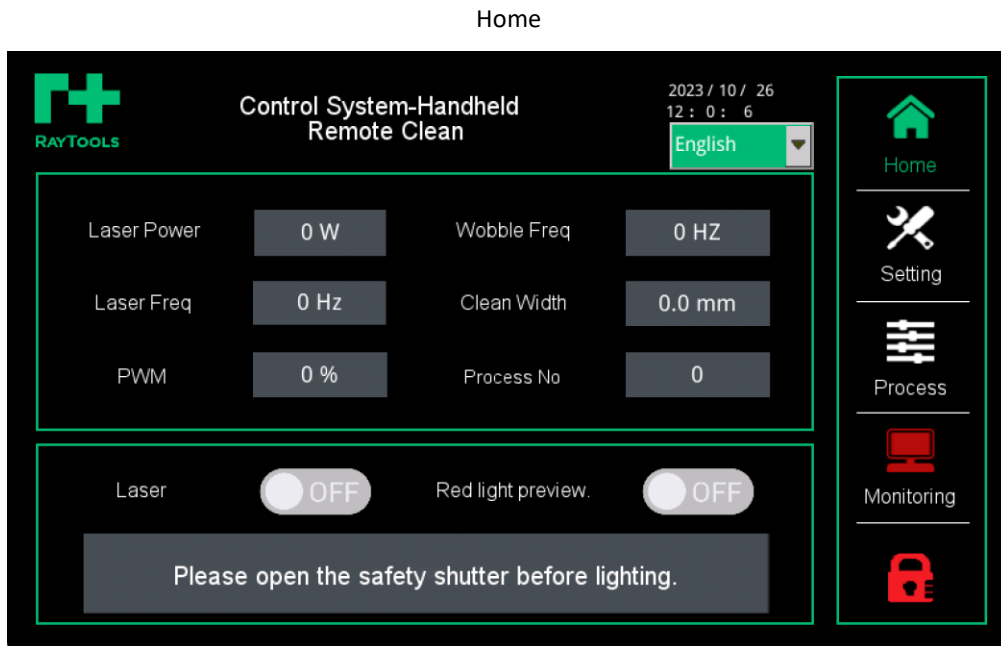
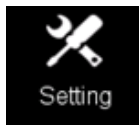

Figure 7.1

### 5.1 Main Interface Description

1. **Laser Power** Laser Power: laser output power: 0-2000W;
2. **Laser Freq** Laser Freq: pulses/s;
3. **PWM** PWM: pulse duration/period;
4. **Wobble Freq** Wobble Freq: wobble frequency setting (>100hz generally) ;
5. **Clean Width** Clean Width: wobble range setting (0-300mm. There is possible difference in actual range due to working distance.) ;
6. **Laser** Laser: switch for laser enable ON/OFF;
7. **Red light preview.** Red light preview: Turn on the red wobble to observe the cleaning width;
8. **Process No** Process No: 16 in total (1-16) . Each process No. match unique cleaning parameters, including laser, wobble and other parameters, which can be selected in the Process interface;
9. **Please open the safety shutter before lighting.** Safety shutter sign: Display the status of safety shutter. If

opening shutter correctly, the sign is red and shows “ Open safety shutter, please be careful”; If without opening shutter or opening incompletely, the sign is gray and shows “Please open the safety shutter before lighting”;



10. Setting: Modify parameters in this interface;

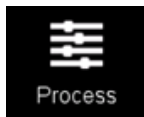

11. Process: Include various process reference parameters and could be modified and selected;



12. Monitoring: Red for alarm, please check IO status and fault signal;



13. Screen locking: Locking the screen to stop operation. It mainly used for preventing accidental touch by other people when operating, resulting in light off in welding or beaming when the operator debugs, to ensure the safety of the operator. When operating, click on the screen locking to unlock it, and click again to lock the screen again;



14. Multi-language switching button: Click the language dropdown box and select the required language.

## 5.2 Setting

### 5.2.1 Basic setting



#### Gas in Advance

Gas in Advance: The time for laser lighting and gas valve blowing in advance after opening switch;

#### Gas Delay

Gas Delay: The time for gas valve stopping blowing after closing switch;

#### Max Power

Max. Power: Setting based on Max. power of laser in actual usage. (range: 0-2000W);

#### Alarm Signal

Alarm Signal: Selecting based on laser and wiring config. in actual usage. (NPN for short circuit)

#### Safety Lock Interval

Safety Lock Interval: Valid interval during clicking lighting button twice;

#### X Magn

Magn: Has been corrected before selling, supporting adjustment if necessary.

## 5.3 Process Library

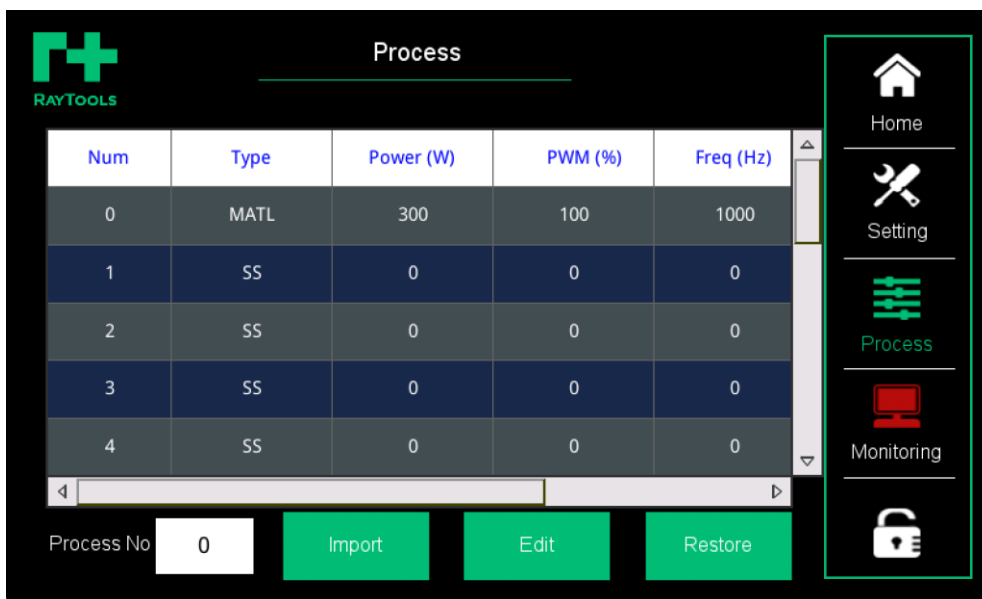

Process Parameters: Displaying each parameter clearly including Type, Power(W), PWM (%) and Freq (Hz);

- Process No Process No: Valid process No. to use after saving modified parameters and back Home by clicking Import;
- Import Import: Click to apply selected Process No;
- Edit Edit: Click Save to save modified parameters;
- Restore Restore: Click to restore factory reset.

## 5.4 Monitoring

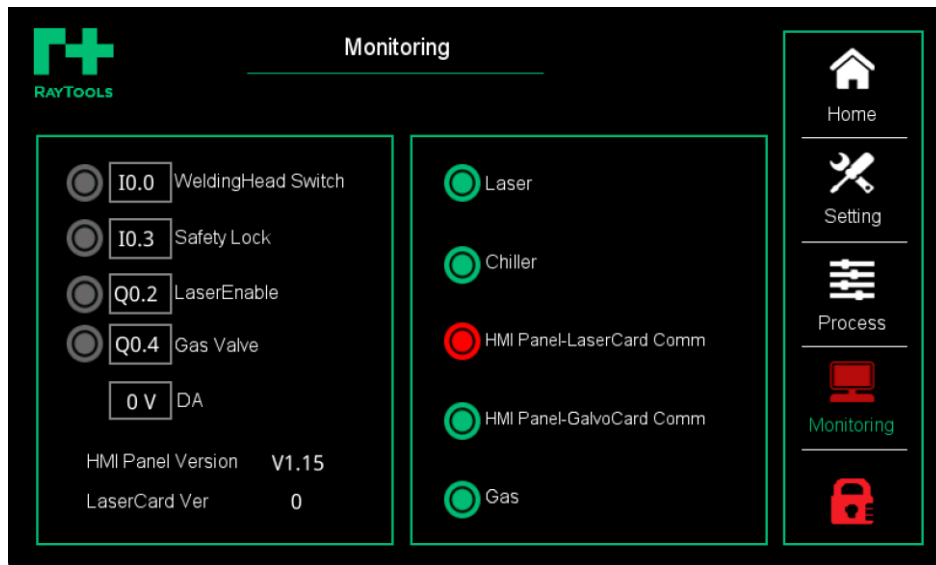

### Input / Output Status:

	I0.0 WeldingHead Switch	I0.0 WeldingHead switch: ON/OFF of cleaning head;
	I0.3 Safety Lock	I0.3 Safety Lock: Whether safety lock is in-pos;
	Q0.2 LaserEnable	Q0.2 LaserEnable: Laser Enable signal output status;
	Q0.4 Gas Valve	Q0.4 Gas Valve: Gas valve output status;
	0 V DA	DA: DA signal output status.

### Alarm signal:

	Laser	Laser: Green for normal and red for abnormal alarm;
	Chiller	Chiller: Green for normal and red for abnormal alarm;
	HMI Panel-LaserCard Comm	HMI Panel-LaserCard Communication: Green for normal and red for abnormal alarm;
	HMI Panel-GalvoCard Comm	HMI Panel-GalvoCard communication: Green for normal and red for abnormal alarm;
	Gas	Gas: Gas pressure alarm, green for normal and red for abnormal alarm;

**HMI Panel Version**  
**LaserCard Ver**

HMI Panel Version & LaserCard Version: Each generation of products matches a corresponding software version. Details here will correspond to the HMI panel, laser card and galvo card version, and the subsequent version upgrading requires to contact the manufacturer.

## Schedule 4: Wiring Diagram between Controller and Fiber Laser

### 1、BWT Laser DB25

No.	Definition	Function	Description
1	Enable+	Enable output signal +	5V-24V, PNP active.
2	Enable-	Enable output signal ground	
3	AD+	Analog output +	0V-10V, control laser output power (10V to 100% output power).
4	AD-	Analog output ground	
5	Bias+	Bias Current +	Max. value: 1V.
6	Bias-	Bias Current -	
7	Input 24V+	Input power supply 24V +	If with laser fault, output external 24V signal from 7/8 ports by 9/10 ports.
8	Input 24V-	Input power supply ground	
9	Fault signal+	Fault signal output +	If with laser fault, output 24V signal from 7/8 ports.
10	Fault signal-	Fault signal output ground	
11	PWM+	Modulation output signal +	Control laser modulation beaming, 10-24V, NPN active.
12	PWM-	Modulation output signal ground	

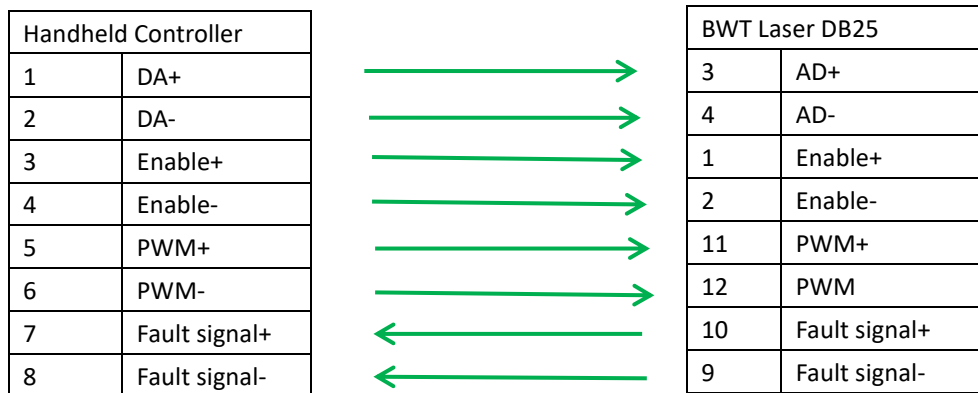



## 2、Reci Laser

Pin	Definition	Remark
1	RS485-A	485 Interface for parameter setting, fault checking and program upgrading.
2	RS485-B	
3	REM_START-	24V NPN active, for starting device remotely (with same functions as Power button).
4	REM_START+	
5	LASER_EN+	24V NPN active, for beaming enable in AD mode.
6	LASER_EN-	
7	KEY_LOCK	Short circuit for normal status and displaying KEY_LOCK alarm for disconnecting. (it's required to set EN by background software.)
8	KEY_LOCK	
9	EX_ALARM_OUT+	Fault signal output +
10	EX_ALARM_OUT+	Fault signal output +
11	EX_ALARM_OUT-	Fault signal output -
12	MOD_SW-	24V NPN active.
13	MOD_SW+	
14	ERROR_OUT (high value for error)	NPN depends on Pin 15 PULL.
15	ERROR_OUT_PULL (available for 5V, 12V and 24V)	
16	EX_ALARM_OUT-	Fault signal output -

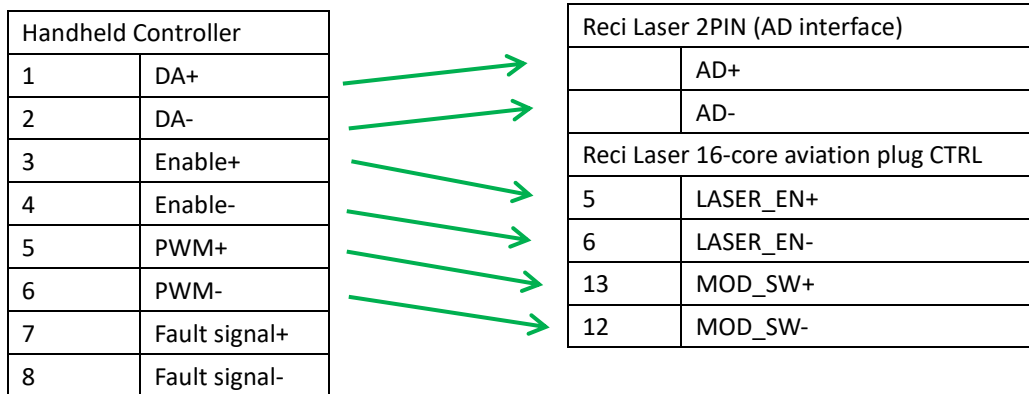

### 3、Maxphotonic Laser Aviation Plug- 12PIN Interface

CTRL interface No.	Wiring color	Function	Description
1	Red	Enable input +	24V VDC NPN active.
2	Red & white	Enable input -	
3	Black	Modulation input +	24V VDC NPN active.
4	Black & white	Modulation input -	
5	Yellow	Beaming +	24V VDC NPN active (the same function as START function in starting switch).
6	Black & yellow	Beaming -	
7	Green	DA(0-10V) input +	0-10V analog signal, control output power.
8	Green & white	DA(0-10V) input -	
9	Brown	Fault input 1	NC with alarm fault; NO without alarm fault.
10	Brown & white	Fault input 2	
11	Blue	NC	
12	Blue & white	NC	

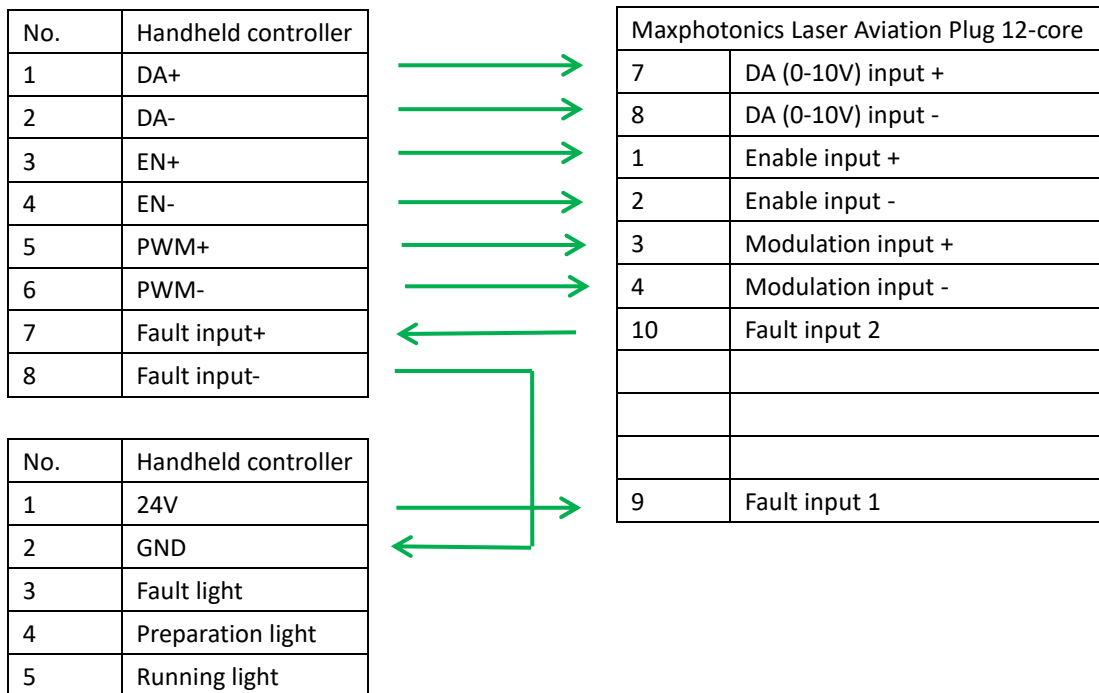

## 4、Raycus 380/220V DB25 PIN

PIN	Item	Input/ Output	Function	Typical value	Min.	Max.	Current	
6	LASER EN	Input	Laser beaming EN signal	EN	24V	15V	28V	<8mA
				No	0V	0V	3V	
7	ADEN	Input	External EN in AD mode	EN	24V	15V	28V	<8mA
				No	0V	0V	3V	
8	Laser Ready	Output	Laser preparing	Ready	24V			<100mA
				Not ready	0V			
9	EXGND		6,7,8,20,24 for reference					
20	EXVCC		24V (power supply for PIN8 & PIN24 output)	24V	20V	28V	<500mA	
22	Analog	Input	Analog external power		0V	10V	<10mA	
23	Laser power	Output	Laser power sign		0V	5V	<20mA	
24	Alarm	Output	Laser abnormality	Abnormal	24V			<100mA
				Normal	0V			
25	AGND		22 & 23 for reference					
Other	NC		No connection					

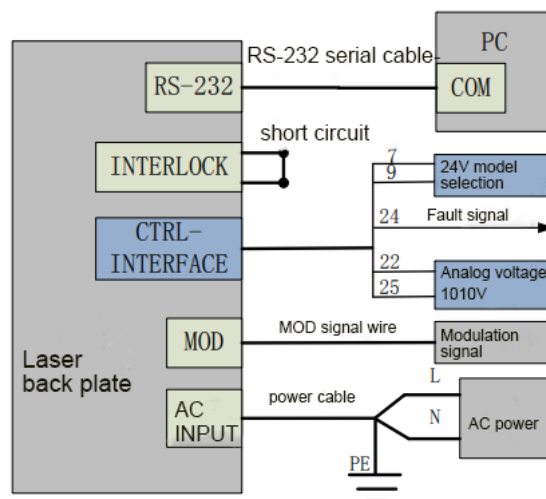
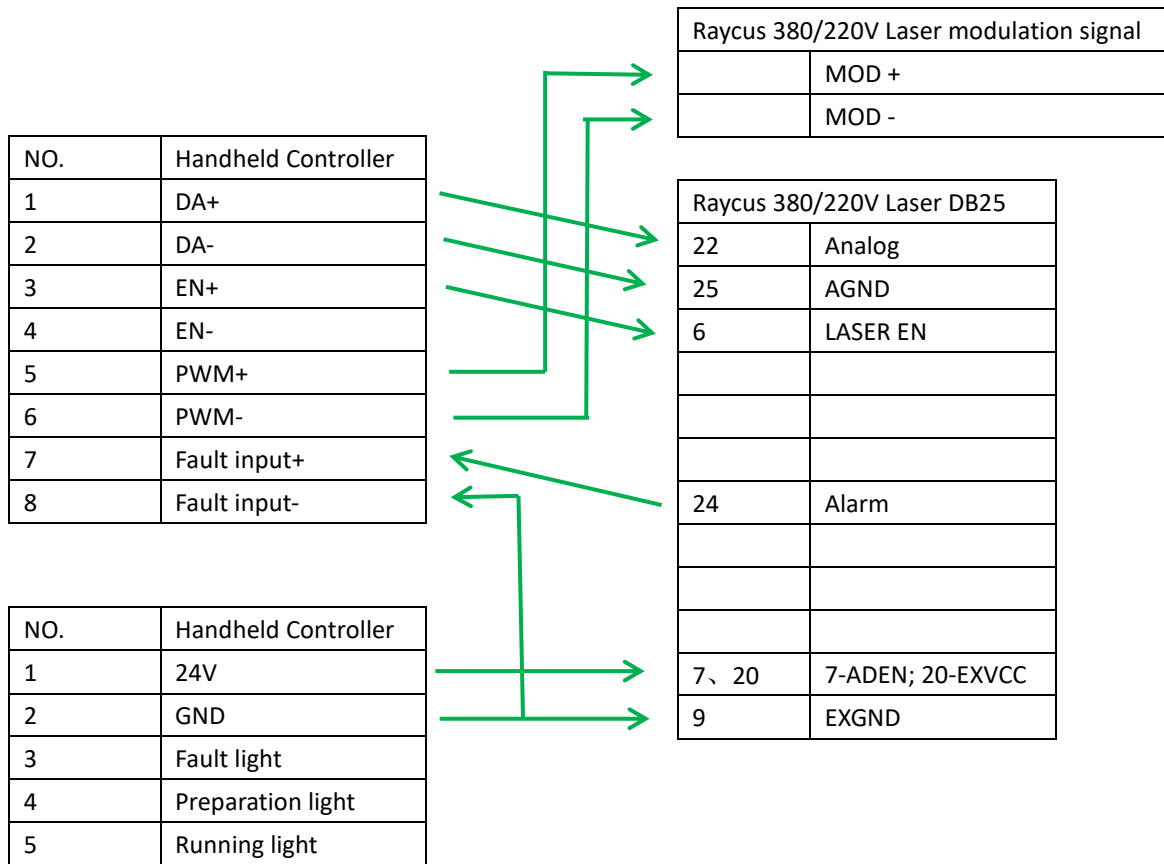
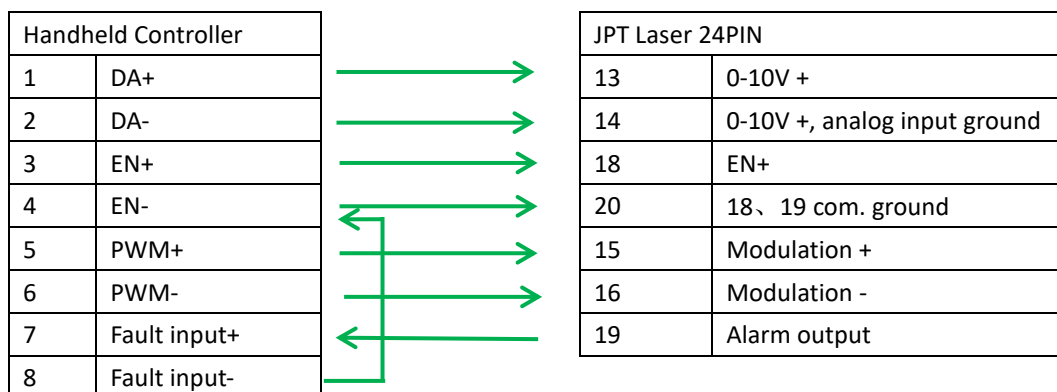

Figure 22 Wiring diagram in AD mode



## 5、JPT Fiber Laser 24PIN

PIN	Item	Type	Level	Description
1				
2				
3	Interlock channel +	Close contact input		Reserve
4	Interlock channel +			
5				
6				
7				
8				
9				
10	Remote starting button +	24VDC		Available to replace START button
11	Remote starting button -			
12				
13	0-10V +	Analog input	1-10VDC	Power control input: 1-10V=10-100% power
14	0-10V analog input ground			12、13 com. ground
15	Modulation +	24VDC		PWM modulation
16	Modulation -			
17				
18	EN +	24VDC		
19	Alarm output	24VDC		PNP with alarm
20	EN-/ alarm output			18、19 com. ground
21				
22				
23				
24				
PE	Ground wire			Grounding



## 6、IPG YLR-Y14

YLR-Y14 interface definition\_Han24

PIN	Item	Type	Level	Drive capacity	Typical response	Description
1	Safety interlock channel 1A	Closed contact input	Internal 24 VDC	1A	<500ms	passive contact and no external voltage or grounding (following EN 954-1/ ISO 13849-1 Cat. 3 PLd
2	Safety interlock channel 2A					
3	Safety interlock channel 2B					
4	Safety interlock channel 1B					
5	RS232 Tx				120 ms	Digital sending
6	RS232 Rx					Digital receiving
7	RS232 Com	Back port				RS-232 back port
8	Remote key switch	Closed contact input	Internal 5 VDC or 24 VDC		20s	Starting internal main control board for power supply in REMOTE mode
9						
10	Remote START button	Momentary closure; Contact input	24 VDC		1s	Starting laser pump power in REMOTE mode
11						
12	Current control (power) input	Analog input 1-10 VDC	1-10 VDC	1 mA (sink)	100μs	Current setting analog input: 1-10 VDX = 10-100% current
13	Laser power sign output	Analog output	0-5 VDC	11 mA (source)	20μs	Analog input 0-4 VDC = 0-P <sub>nom</sub>
14	Analog com. ground	Back port				12、13 com. ground
15	Modulation +	Digital input	5-24 VDC	6 mA (sink)	20μs	5-24 VDC PWM signal input
16	Modulation -	Back port				Back port of 15PIN
17	Leading red control	Digital input	5-24 VDC	6 mA (sink)	120 ms	Rising edge in REMOTE mode
18	Laser EN	Digital input	5-24 VDC	6 mA (sink)	120 ms	Rising edge in REMOTE mode
19	Fault/ RDY	Digital output	24 VDC	100 mA (source)	120 ms	PNP=alarm, NPN= RDY
20	System com. ground	Back port				17/18/19/21/22/23/24 com. ground
21	Fault reset	Digital input	5-24 VDC	6 mA (sink)	120 ms	Rising edge reset (resettable alarm)
22	System power on	Digital output	24 VDC	100 mA (source)	120 ms	NPN = System power on
23	Main power starting	Digital output	24 VDC	100 mA (source)	120 ms	NPN = Main power starts
24	Laser emitted	Digital output	24 VDC	100 mA (source)	120 ms	NPN = laser EN

## 7、Feibo Laser

PIN	Signal	Description
1	INTLK1A	Interlocking switch 1A, 1A1B close active
2	INTLK2A	Interlocking switch 2A, 2A2B close active
3	INTLK2B	Interlocking switch 2B, 2A2B close active
4	INTLK1B	Interlocking switch 1B, 1A1B close active
5	RS232 RX	RS232 receiving, no use with DB9-RS232
6	RS232 TX	RS232 sending, no use with DB9-RS232
7	CASE	RS232、RS485 signal ground
8	RS485_D+	Spare communication interface (RS485)
9	RS485_D-	Spare communication interface (RS485)
10	NC	No contact for internal testing signal
11	NC	No contact for internal testing signal
12	IFWD_SET	Power setting input (0-10V) 1-10V analog voltage = 10-100% output power 0-1V: 0V; >10V: 10V
13	IFWD_FB	Reserve
14	CASE	Analog voltage (Pin 12) signal ground
15	CASE	External contact signal input, 16-24V active
16	GND_IO	External interface signal ground (Pin15-Pin24)
17	RED_EN	Signal light EN input 24V: ON / 0V: OFF
18	EX_EN	External EN input 24V: control EN / 0V: control stop
19	FAULT	Fault signal output signal 24V: YES / 0V: NO
20	GND_IO	External interface signal ground (Pin15-Pin24)
21	WARNING	Alarm sign output signal 24V: YES / 0V: NO
22	PWR	Power on sign output signal 24V: Normal / 0V: Abnormal
23	EN_ON	EN sign output signal 24V: YES / 0V: NO
24	EN_ON	Beaming sign output signal 24V: YES / 0V: NO
25	NC	

