

Thermo  Drain

TECHNICAL GUIDE

ThermoDrain™ Heat Exchangers

INDEX

01	About us	4
02	Technical characteristics	5
03	Applications	6
04	Design and operation	6
05	Installation of the ThermoDrain™	7
5.1	Connection modes	8
5.1.1	Preheating of cold and hot water (equal flow)	8
5.1.2	Preheating of cold water only (unequal flow type “A”).....	10
5.1.3	Preheating of hot water only (unequal flow type “B”).....	12
5.2	Types of configurations	14
5.2.1	Decentralized water heating.....	14
5.2.2	Centralized water heating	15
5.2.3	Centralized water heating pumped loop.....	16
5.2.4	Distributed unit installation, cold water preheat.....	17
5.2.5	Distributed unit installation, equal flow preheat	18
5.2.6	Grouped unit installation	19
5.2.7	Commercial washer application.....	20

INDEX

5.3	Installation considerations	21
5.4	Detailed installation guide for the ThermoDrain™	23
06	Recovery calculation.....	29
6.1	Calculating the preheating of hot and cold water	30
6.2	Calculating the preheating of cold water only	31
6.3	Calculating the preheating of hot water only	31
07	System design.....	32
08	Specification sheets	33
8.1	TD series 3" drain diameter	33
8.2	TD series 4" drain diameter	39
8.3	TDH high performance series 3" drain diameter	45
09	Sample images of commercial applications	49

1 - ABOUT US

In 2006, Daniel Beauchemin came across something a little strange in his Canadian back yard that prompted action. You see, it is not every day that you will see healthy green grass growing over a septic tank in the middle of a cold Canadian winter. What this grass represented was a significant waste of heat energy and money. At this time, energy efficiency was starting to make its way into new home construction vocabulary. Knowing very well that this wasted energy must somehow be recoverable, Daniel met up with his friend Marc Fontaine to discuss a solution.

Marc and Daniel began to crunch the numbers and the potential for energy savings was incredible. They went straight to work on designing the ThermoDrain™. A passive heat exchanger that would assist in recovering and reusing this wasted heat energy. In 2007, Daniel and Marc founded EcoInnovation Technologies and began manufacturing the ThermoDrain™. Today, EcoInnovation has grown to be one of the largest manufacturers of high quality, high-performance drain water heat recovery systems in the world.

Our values

Responsibility – We are the industry leader; our goal is to provide high-quality products and service to all our clients.

Integrity – We believe that trust is a fundamental requisite of good business. We are open, honest and respectful to all our customers and colleagues.

Customer service – We build long-lasting relationships with our clients providing them all the support they require for their projects.

Our vision

To be a world leader in sustainable and affordable energy solutions.

Mission statement

To be the ultimate solution and standard for drain water heat recovery technology.

2 - TECHNICAL CHARACTERISTICS

General description

ThermoDrain™ heat exchanger units recover energy from waste water in applications from residential, institutional, commercial and industrial processes. Their robust copper construction makes it possible to obtain high energy recovery and offers increased durability benefits.

ThermoDrain™ heat exchangers have a unique design best suited for plumbing applications in buildings that use warm water continuously or in batches and where the recovery of the energy is desired.

Advantages

- ▶ High efficiency
- ▶ Simple installation
- ▶ No maintenance
- ▶ Durable and robust construction
- ▶ Significant reduction in the cost of heating water
- ▶ Increase in capacity of the water heater
- ▶ Multiple installations possible

Technical specifications

- ▶ Built from ASTM 306 copper drain tubing and ASTM B-88 Type L potable water copper tubing
- ▶ Suitable for most water flow rate requirements
- ▶ Permissible drain flow rates designed to that of the original drain pipe diameter
- ▶ Recovered power exceeding 22 kW on some models
- ▶ Low pressure drop
- ▶ Parallel coils available
- ▶ Compatible with potable water use
- ▶ Available with drain diameter of 3", 4" and 6"
- ▶ Available with connections of 1/2", 3/4" and 1"
- ▶ Available in lengths from 12" to 100"
- ▶ Available with three water connection options: factory installed crimp PEX fittings CSA B137.5 and ASTM F1807, factory installed cold expansion PEX fittings ASTM F1960 and 3/4" male copper tubing

3 - APPLICATIONS

ThermoDrain™ applications will generate significant energy savings and high rates of return on investment.

Some examples:

- Showers (single or multiple) :
 - ▶ Residential units, condominiums, affordable housing, and co-ops
 - ▶ Hotels, motels and retreats
 - ▶ Sport centers, fitness centers
 - ▶ Relaxation centers, spas
- Commercial and institutional laundry facilities
- Processes of sterilization or pasteurization
- Restaurants and dishwashers
- Hair salons
- Industrial washing and treating
- and much more

4 - DESIGN AND OPERATION

The ThermoDrain™ consists of a copper pipe tightly wound around a vertical section of a copper drainpipe. The energy recovery works under the principle of gravity film exchange. As warm water flows down the drain, it clings to the inside surface. The heat from the waste water is transferred through the copper drainpipe to fresh cold water flowing in the outer copper coil of the ThermoDrain™. The heat exchange is thus completed with no contamination risk to the incoming cold water. The preheated water is then sent to the water heater, to the plumbing fixture or both. The ThermoDrain™ has been designed without any moving parts or sealing joints, thereby eliminating maintenance issues.

5 - INSTALLATION OF THE THERMODRAIN™

The ThermoDrain™ must be installed vertically so that a uniform film can form on the inside of the heat exchanger and ensure maximum efficiency. An angled or horizontal installation will significantly lower the efficiency of the unit. In certain applications, the horizontal orientation of the ThermoDrain™ may be a viable option.

The following factors need to be considered before installing the ThermoDrain™.

- ▶ The desired connection mode
- ▶ The flow rates of the drain water and cold water
- ▶ The desired efficiency of the system
- ▶ The configuration of the hot water source (centralized or distributed)
- ▶ The budget allocated to recover drain water heat energy
- ▶ The plumbing systems architecture

For more information on the installation of the ThermoDrain™ heat exchanger, consult the Detailed installation guide for the ThermoDrain™ in [section 5.4](#).

5.1 - CONNECTION MODES

From the various installation possibilities, the pressure drop must be determined to evaluate the impact of the ThermoDrain™ on the entire plumbing system. The efficiency of the heat exchanger is directly related to the distribution of the preheated water, which in turn affects the flow rate of the drain water in relation to the flow rate of the cold water in the outer coils. Note that, the drain water flow is calculated by the sum of the cold water flow and the hot water flow to the plumbing fixtures.

5.1.1 - PREHEATING OF COLD AND HOT WATER (EQUAL FLOW)

In an equal flow connection mode, the water flowing in the ThermoDrain™ coil is directed to both the water heater and cold water plumbing fixtures. The rate of the drain water flowing through the central copper drain pipe is equal to the flow rate of the cold water circulating in the outer coil.

It is characterized by superior heat exchange efficiency, compared to the unequal flow type "A" and "B".

It may also involve a more complex distribution system due to the distances that may separate the plumbing fixture, the ThermoDrain™ and the hot water source.

Preheated water enters the water heater immediately reducing the energy required to heat the water. The cold side of the plumbing fixtures will receive preheated cold water instead of the usual cold water, and therefore the desired water temperature is then obtained using less energy.

Though it may be practical to connect the ThermoDrain™ preheated water outlet to the entire bathroom cold water supply, note that this will have the effect of providing lukewarm water at the cold fixtures in the bathroom during shower operation.

Refer to schematic #1

Schematic #1 : Equal flow

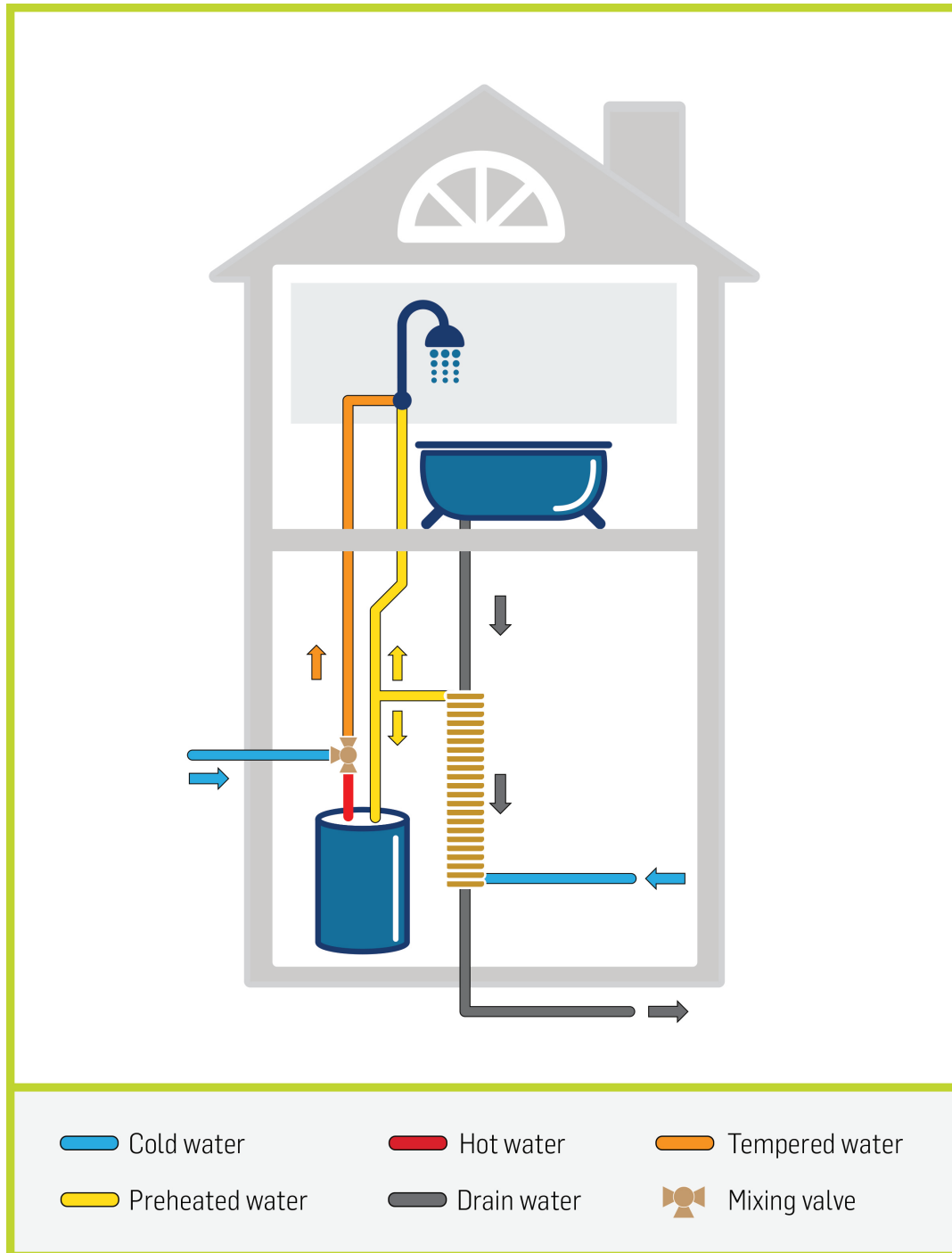

5.1.2 - PREHEATING OF COLD WATER (UNEQUAL FLOW TYPE "A")

In an unequal flow type "A" connection mode, the water flowing in the ThermoDrain™ coil is only directed to the cold water plumbing fixtures. The rate of the drain water flowing through the central copper drain pipe is greater than the flow rate of the preheated cold water, therefore, creating an unequal flow.

The efficiency is significantly increased when the cold water flow rate is greater than the hot water flow rate from the water heater.

It is characterized by the simplicity of the installation when the ThermoDrain™ is installed close to the cold water line that feeds the plumbing fixtures and is very far from the water heater(s).

The cold side of the plumbing fixtures will receive preheated cold water, and therefore the desired water temperature is then obtained using less energy.

Note that this connection mode is sensitive to variations in drain temperatures and must be considered when designing the system. It is recommended that a thermostatic mixing valve is used to ensure comfort to the user under changing drain temperature conditions.

Though it may be practical to connect the ThermoDrain™ preheated water outlet to the entire bathroom cold water supply, note that this will have the effect of providing lukewarm water at the cold fixtures in the bathroom during shower operation.

Refer to Schematic #2.

Schematic #2 : Unequal flow type "A"

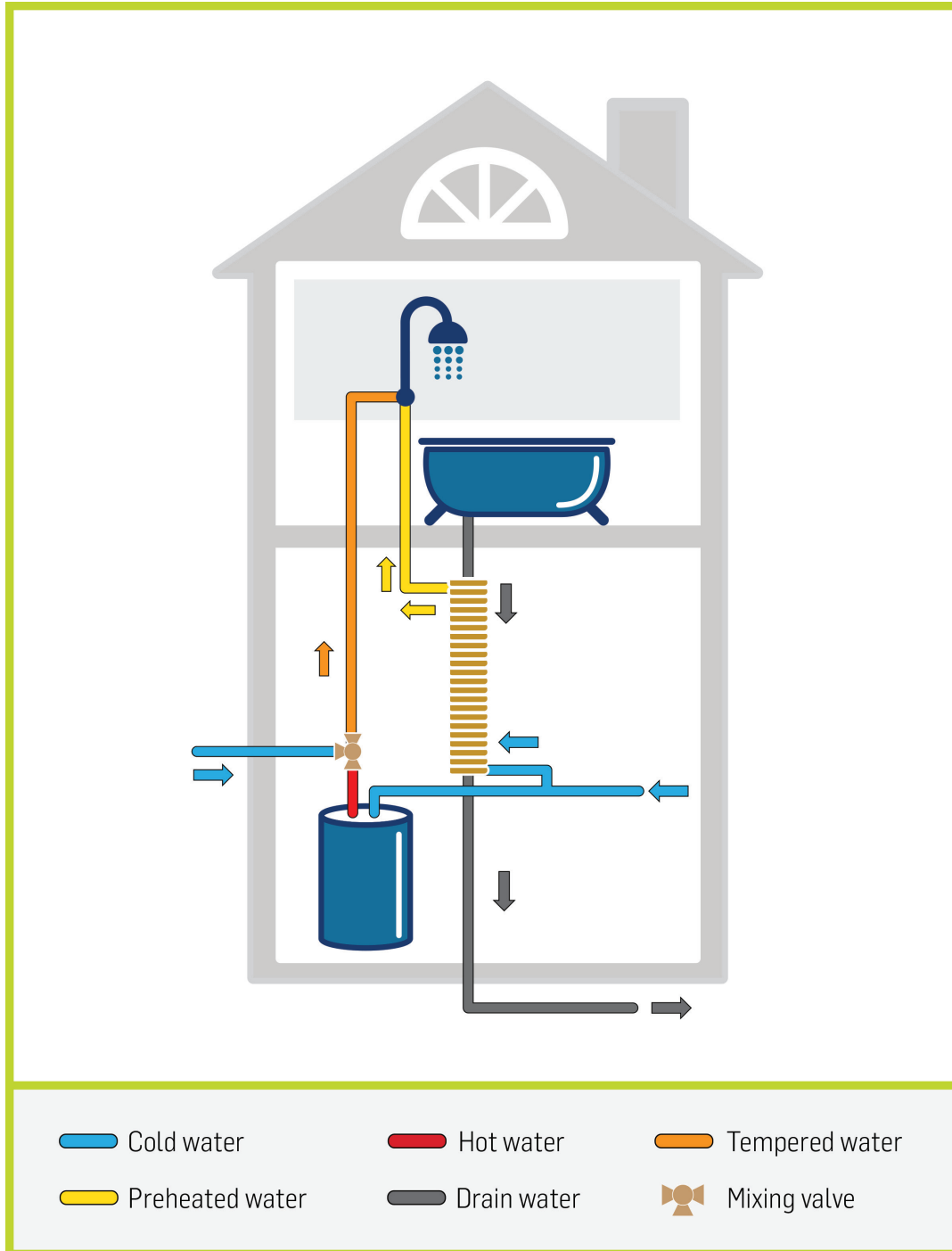

5.1.3 - PREHEATING HOT WATER ONLY (UNEQUAL FLOW TYPE "B")

In an unequal flow type "B" connection mode, the water flowing in the ThermoDrain™ coil is only directed to the water heater. The rate of the drain water flowing through the central copper drain pipe is greater than the flow rate of the preheated cold water, therefore, creating an unequal flow.

The efficiency is significantly increased when the hot water flow rate is greater than the cold water flow rate from the water heater.

It is characterized by the simplicity of the installation when the ThermoDrain™ is installed close to the water heater(s).

The water heater will receive the preheated cold water, and therefore the water heater is using less energy.

Note that, this connection mode is not sensitive to variations in drain temperatures. This does not need to be considered when designing a plumbing system.

Refer to Schematic #3

Schematic #3 : Unequal flow type "B"

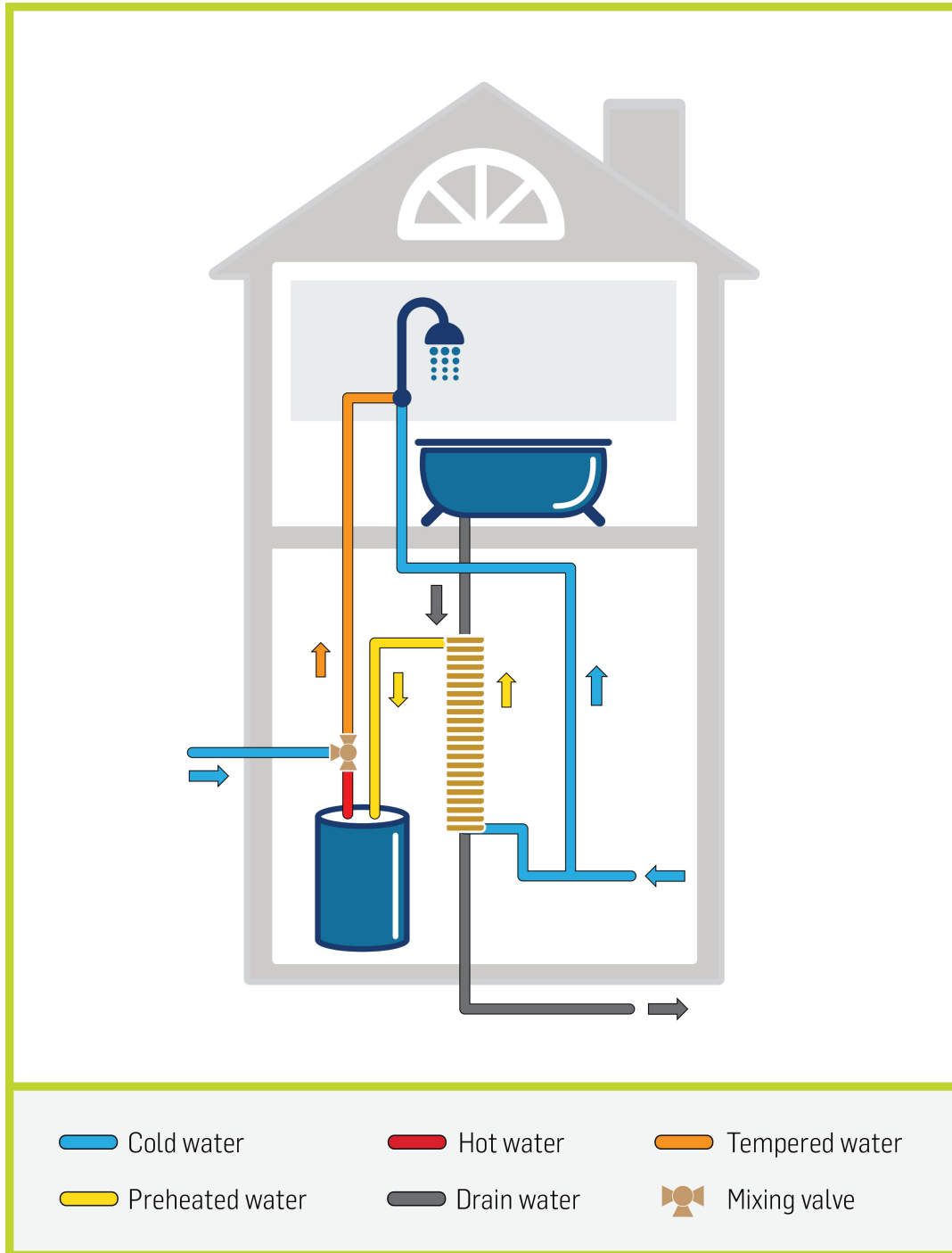

5.2 - TYPES OF CONFIGURATIONS

The choice of configuration is dependent on the desired results for the heat recovery units as well as the existing or designed plumbing system for each building. Some examples of configurations are given below and may serve as a basis for designing your type of installation.

5.2.1 - DECENTRALIZED WATER HEATING

- ▶ Best suited for low- or high-rise buildings with decentralized water heating
- ▶ Simple installation
- ▶ May combine multiple dwellings on the same ThermoDrain™ unit.
- ▶ High efficiency
- ▶ Low cost system

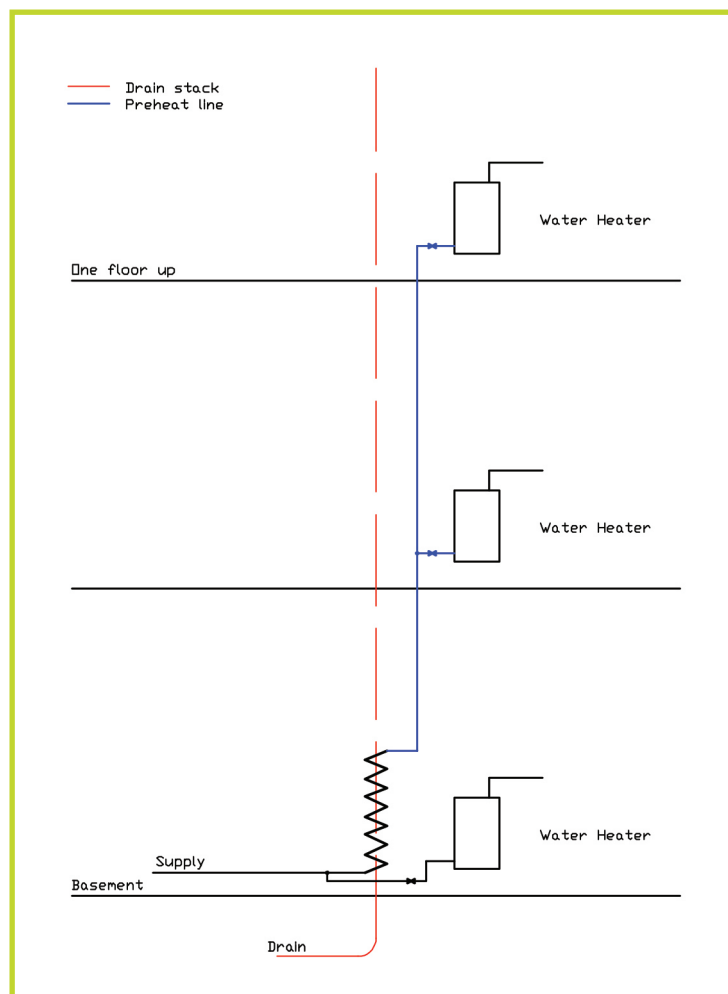

5.2.2 - CENTRALIZED WATER HEATING

- ▶ Best suited for low-rise buildings with centralized water heating with low hot water flow demand not exceeding the ThermoDrain™ capacity
- ▶ Simple installation
- ▶ May combine multiple dwellings on the same ThermoDrain™ unit
- ▶ Low efficiency
- ▶ Low cost system

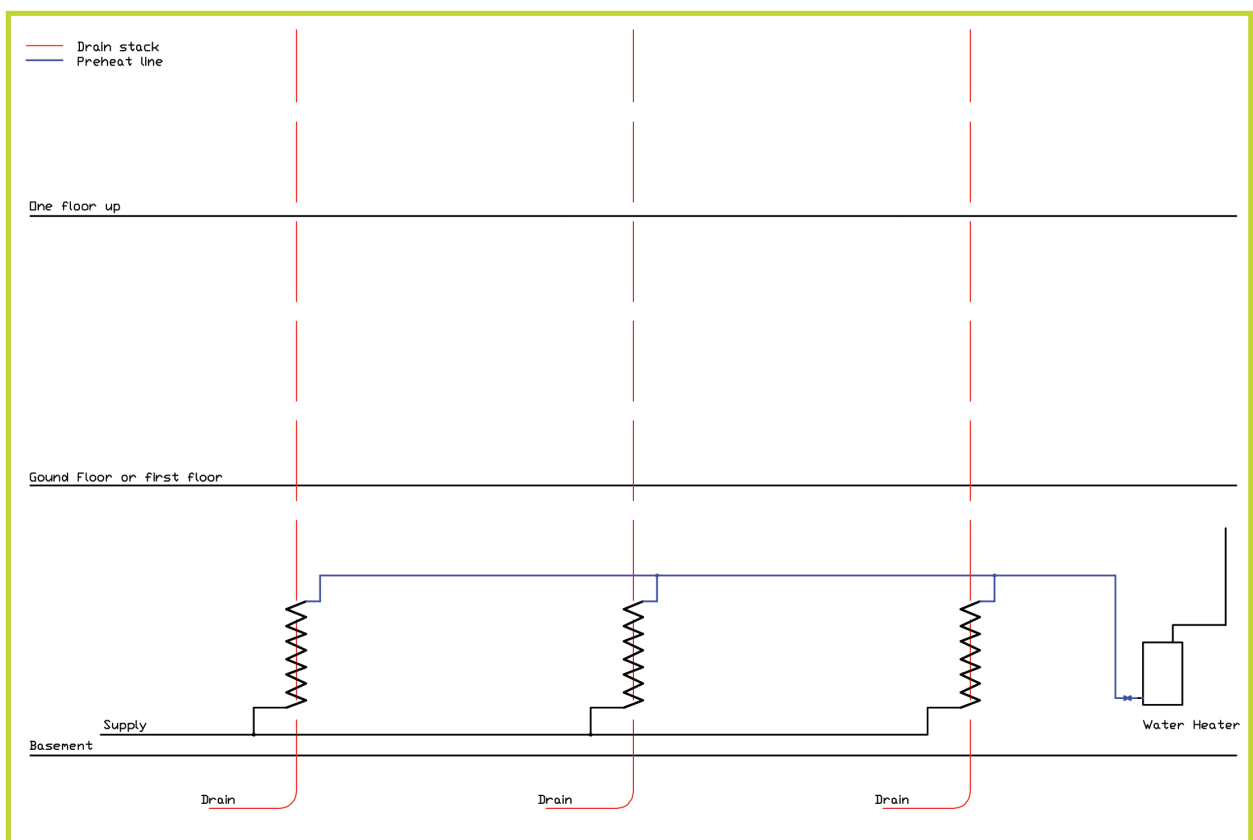

5.2.3 - CENTRALIZED WATER HEATING PUMPED LOOP

- ▶ Best suited for high-rise buildings with centralized water heating with high hot water flow demand exceeding the ThermoDrain™ capacity
- ▶ A pumped loop provides preheated water when hot water demand is present
- ▶ Slightly more complex installation (pump required)
- ▶ May combine multiple showers on the same ThermoDrain™ unit
- ▶ Low efficiency
- ▶ Low cost system

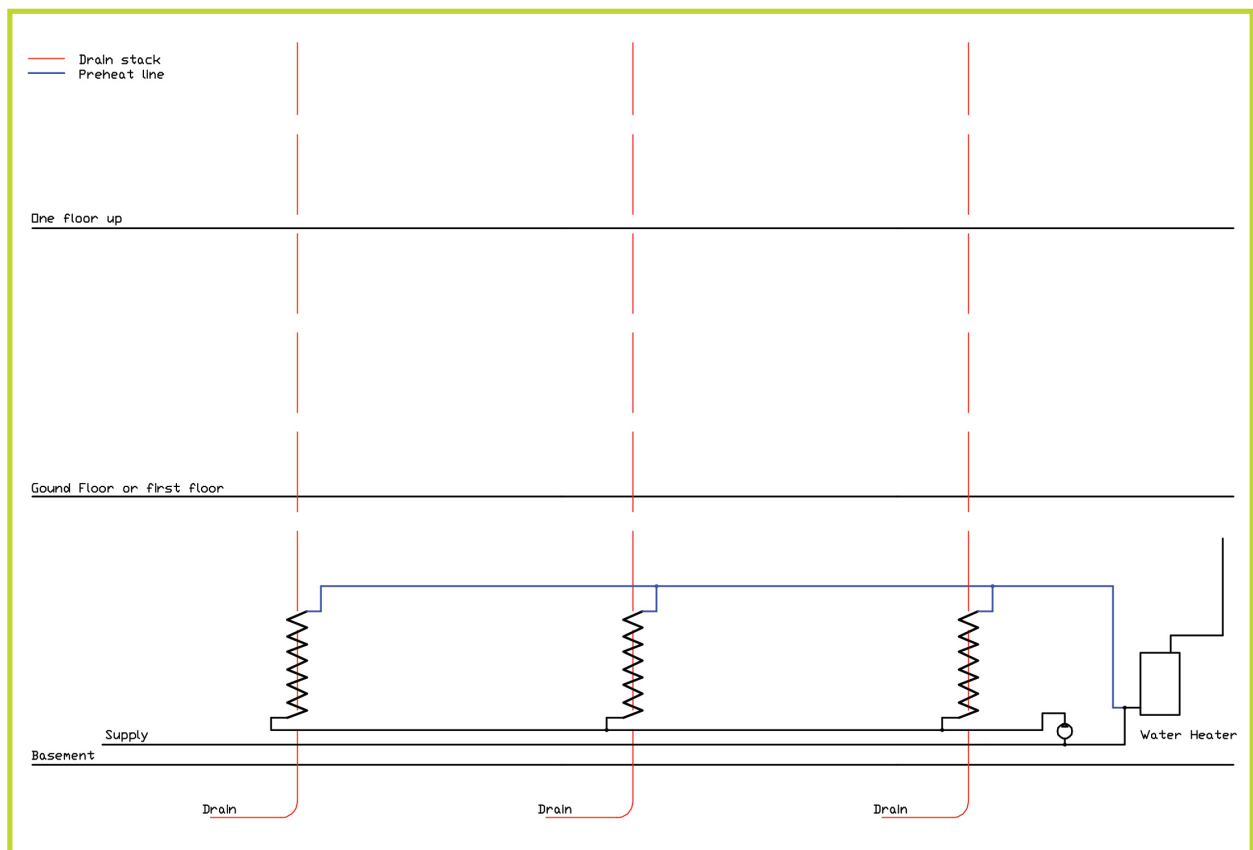

5.2.4 - DISTRIBUTED UNIT INSTALLATION, COLD WATER PREHEAT

- ▶ Best suited for low- or high-rise buildings
- ▶ Simple installation given that only the cold water is preheated
- ▶ May combine multiple showers on the same ThermoDrain™ unit
- ▶ High efficiency
- ▶ Higher cost system

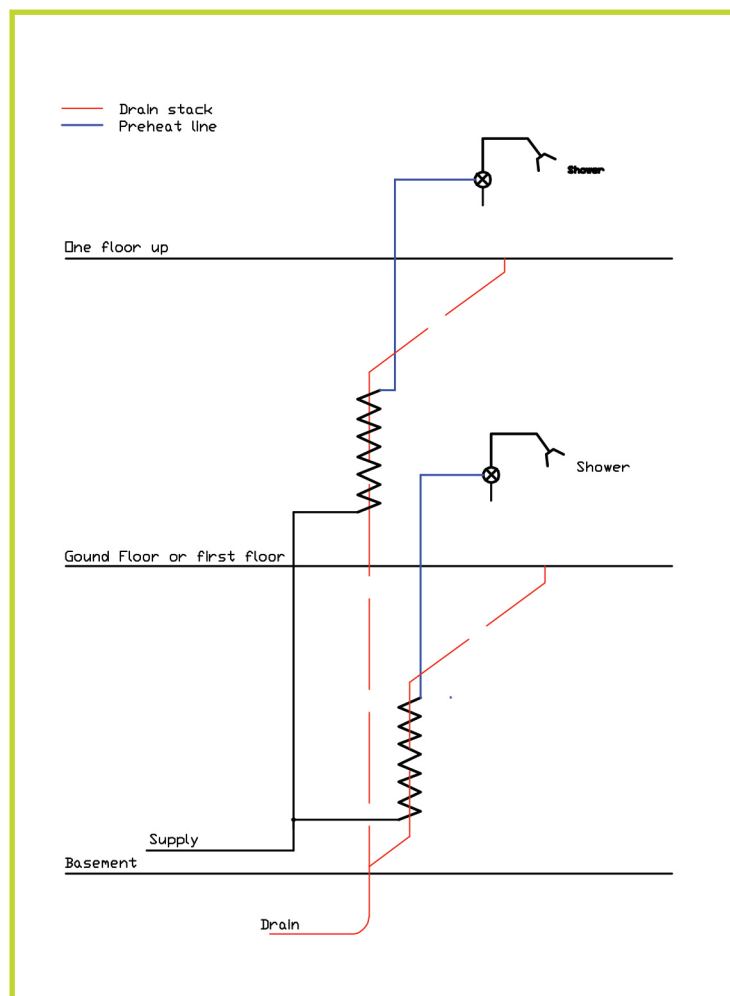

5.2.5 - DISTRIBUTED UNIT INSTALLATION, EQUAL FLOW PREHEAT

- ▶ Best suited for low- or high-rise buildings with individual water heaters in each dwelling
- ▶ Simple installation given that only the hot water is preheated
- ▶ May combine multiple showers on the same ThermoDrain™ unit
- ▶ High efficiency
- ▶ High cost system

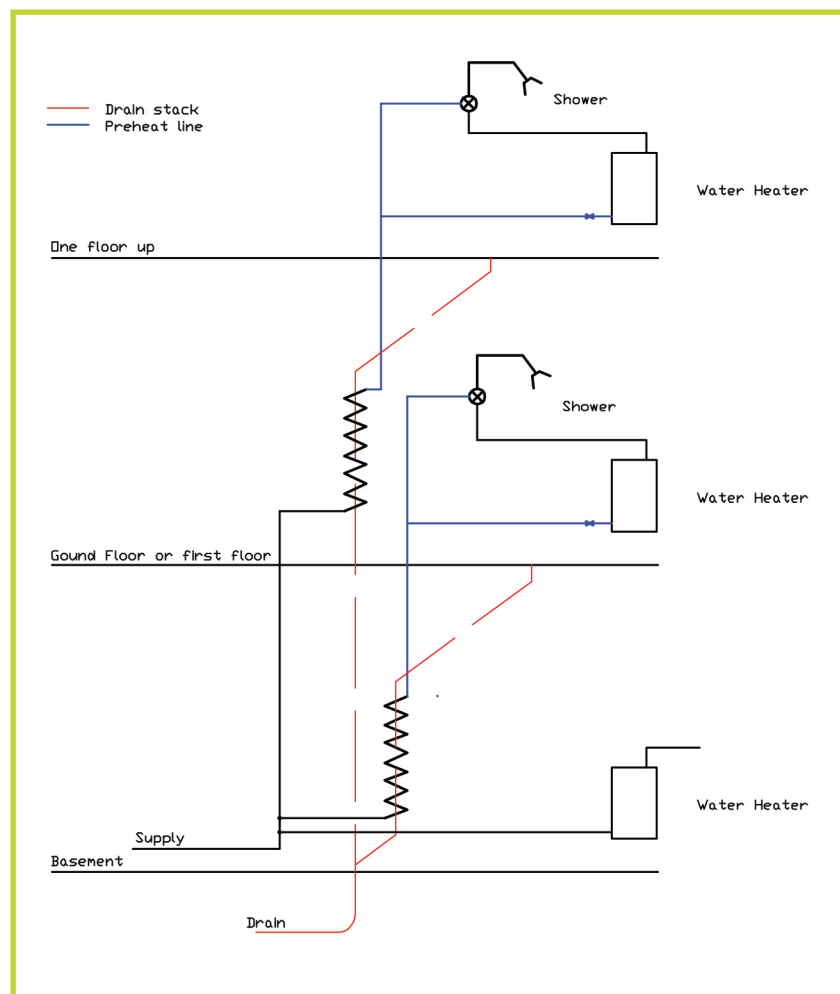

5.2.6 - GROUPED UNIT INSTALLATION

- ▶ Best suited when equal flow or hot water preheat modes are desired from a single mechanical room as well as for retrofit projects where a heat recovery system is desired given that there is access to the plumbing system
- ▶ Complex installation that requires a drainage system that leads towards several ThermoDrain™ units that have both preheated water and drain water flows connected in parallel. Designed for large flow rates generated when multiple shower fixtures are working simultaneously. It is adapted to service plumbing fixtures with different locations in the building that share the same drain stack and a single source of hot water
- ▶ May combine multiple showers on the same ThermoDrain™ unit
- ▶ Efficiency is directly related to the average temperature circulating in the drain
- ▶ Low cost system

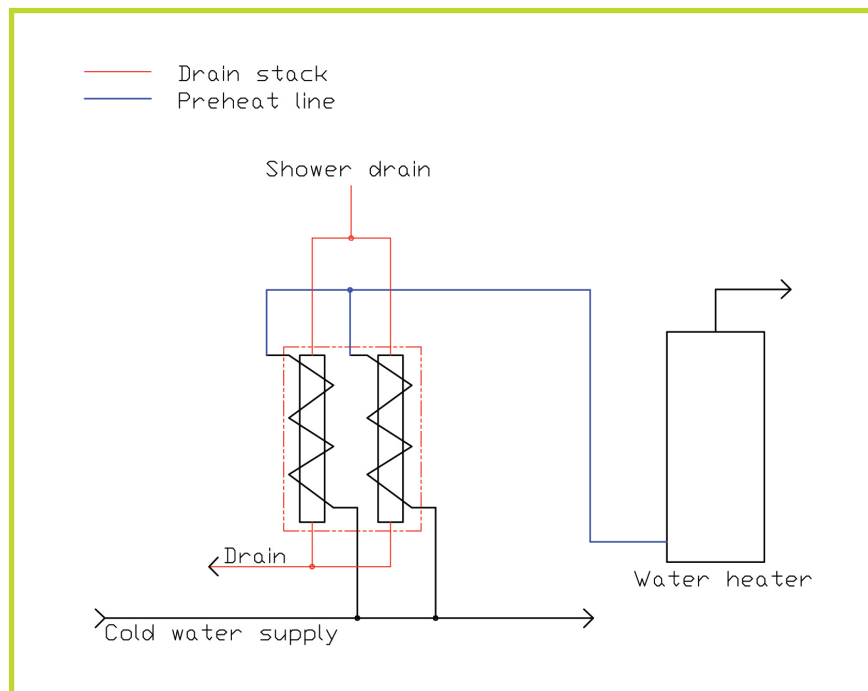

5.2.7 - COMMERCIAL WASHER APPLICATION

Many washing applications may benefit from drain water heat recovery. This example demonstrates how waste heat can be captured and stored in a batch process until there is a demand for hot water. When hot water is drained from the washer this event is detected by the flow switch and the preheat loop pump is energized. This process preheats the cold water going through the ThermoDrain™ and sends it to the storage tank. When hot water is required to fill the washer at a later time, the preheated water enters the water heater and provides the energy savings.

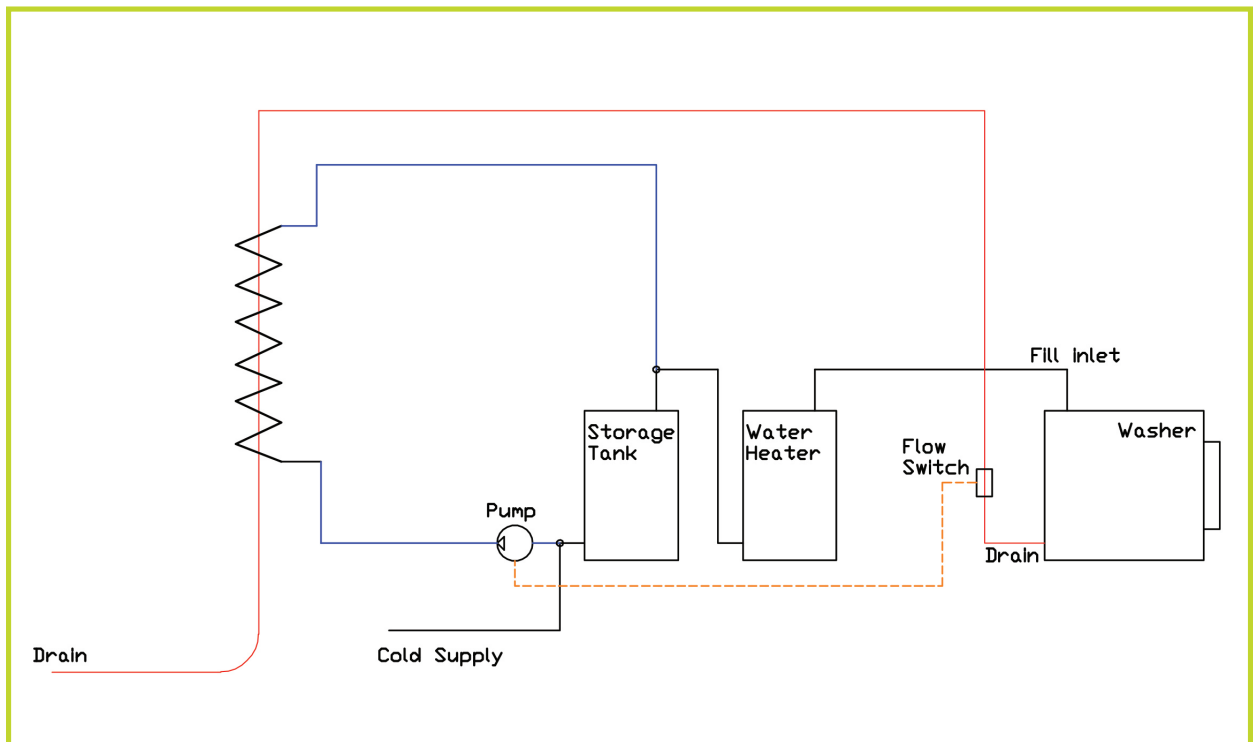

5.3 - INSTALLATION CONSIDERATIONS

In choosing the best installation configuration, it is essential to consider the efficiency, the comfort of the users and the cost and complexity of the installation. A technical representative from EcoInnovation Technologies will assist you in determining the optimal configuration.

- ▶ For horizontal applications, please consult a technical representative from EcoInnovation Technologies.
- ▶ It is recommended that the ThermoDrain™ be installed in an equal flow configuration to achieve the maximum efficiency ratings. However, unequal flow configurations will still provide high efficiency systems.
- ▶ For more information on the installation of the ThermoDrain™ heat exchanger contact a technical representative from EcoInnovation Technologies to assist you in determining the optimal installation configuration.

5.4 - DETAILED INSTALLATION GUIDE FOR THE THERMODRAIN™

WARNING

Carefully read the instructions before starting the installation of the ThermoDrain™ and proceed with the inspection of the unit for signs of damage in transit. Refer to the technical or installation drawing provided by the general contractor for references on installation. The installation should be done by a licensed plumber. The plumbing system must be shut off and guarded against accidental pressurization or drainage events during the entire installation process. However, the installer is responsible for any code requirements for things such as bypass valves, access traps, supports, etc.

INSTALLATION

Refer to national and local code requirements before installation. The ThermoDrain™ must be installed in a vertical position ONLY. Any other position will reduce the efficiency of the product. A maximum deviation of 1/8" per linear foot from vertical is acceptable. Provide suitable support for the ThermoDrain™ such that the weight of the unit either rests on rigid and supported pipe work or is attached to the wall or ceiling by hangers. The unit may NOT hang from the upper mechanical coupling. Clamps or hangers in direct contact with the unit shall be copper or with non metallic coating to prevent galvanic corrosion if a wall or ceiling support is required. Properly support the upper and lower part of the drain pipes BEFORE cutting into the drain stack to avoid the risk of serious injury or system failure. Stacks with cast iron pipes may require particular attention as the weight can be significant. If an expansion joint is installed on the drain stack, it should be placed above the ThermoDrain™ unit to minimize support requirements where allowed. Do NOT install the unit in a location where freezing may occur. Pressure test the plumbing system upon final assembly.

INSULATION

Unless insulation is required by the applicable codes or is specified by the technical requirements, it is not necessary to insulate the ThermoDrain™ as this will only marginally increase the effectiveness. However, insulation will greatly reduce condensation on the ThermoDrain™ as it would with any copper pipe with cold water flow. When insulation is required, use insulation impervious to moisture. Refer to the local code requirements.

DRAIN CONNECTION

The ThermoDrain™ must have the same nominal diameter as the host drain pipe. Since the heat exchanger is symmetrical, any end can be installed upwards unless noted "TOP" on the unit.

A straight section of drain pipe of at least 12" in length is recommended above the ThermoDrain™ to ensure the best efficiency. Only 3" of pipe are required at the bottom to allow for installation of the mechanical coupling. The distance between the upper and lower drain pipe ends should be approximately 1/2" longer than the height of the ThermoDrain™ unit being installed.

The drain stack must be located at least 1" from a wall to allow the ThermoDrain™ installation. Supplied mechanical couplings may be used with plastic or cast iron stacks. The upper mechanical joint connecting the drain pipe to the ThermoDrain™ should be inserted onto both pipes to ensure proper water film formation.

To install the lower mechanical joint, remove the stainless steel band and slip it over the drain pipe. Install the mechanical joint on the drain pipe and the ThermoDrain™. Slip the stainless steel band back on the joint and tighten to 60 in. lbs. Recheck the vertical mounting and adjust as required. Check that the unit is properly supported.

POTABLE WATER CONNECTION

If the unit doesn't have factory installed fittings, install the required fittings to the cold water side of the ThermoDrain™. A maximum temperature of 572°F is allowed during the installation of the fittings.

Warning: Do not use quick connect type, push-in type, compression type, and press type fittings. For ThermoDrain™ with ½" tube, use only ½" copper fitting and for ¾" PEX size fittings, use ¾" PEX tubing.

The cold water inlet is located at the bottom of the ThermoDrain™. Do not connect otherwise as units are designed as counterflow heat exchangers. The preheated water outlet is located at the top of the ThermoDrain™.

CONNECTION TO A PLUMBING DEVICE

The preheated outlet of the ThermoDrain™ should not supply a water softener, filtration equipment or the cold inlet of a central thermostatic mixing valve. If a local thermostatic mixing valve is used to limit the shower or bath temperature only, adjust after installation is completed.

Though it may be practical to connect the ThermoDrain™ preheated water outlet to the entire bathroom cold water supply, note that this will have the effect of providing lukewarm water at the cold fixtures in the bathroom during shower operation.

NEVER attempt to dismantle a unit or a component of the unit as significant tension is present in the coiled tube. Uncoiling may lead to serious injury. Never install or repair a damaged unit.

INSTALLATION WITH A SINGLE SHOWER

ThermoDrain™ with ½" tube should be installed in configurations #3 or #4 and as per local code. ThermoDrain™ with ¾" tube can be installed in any of the configurations as per local code.

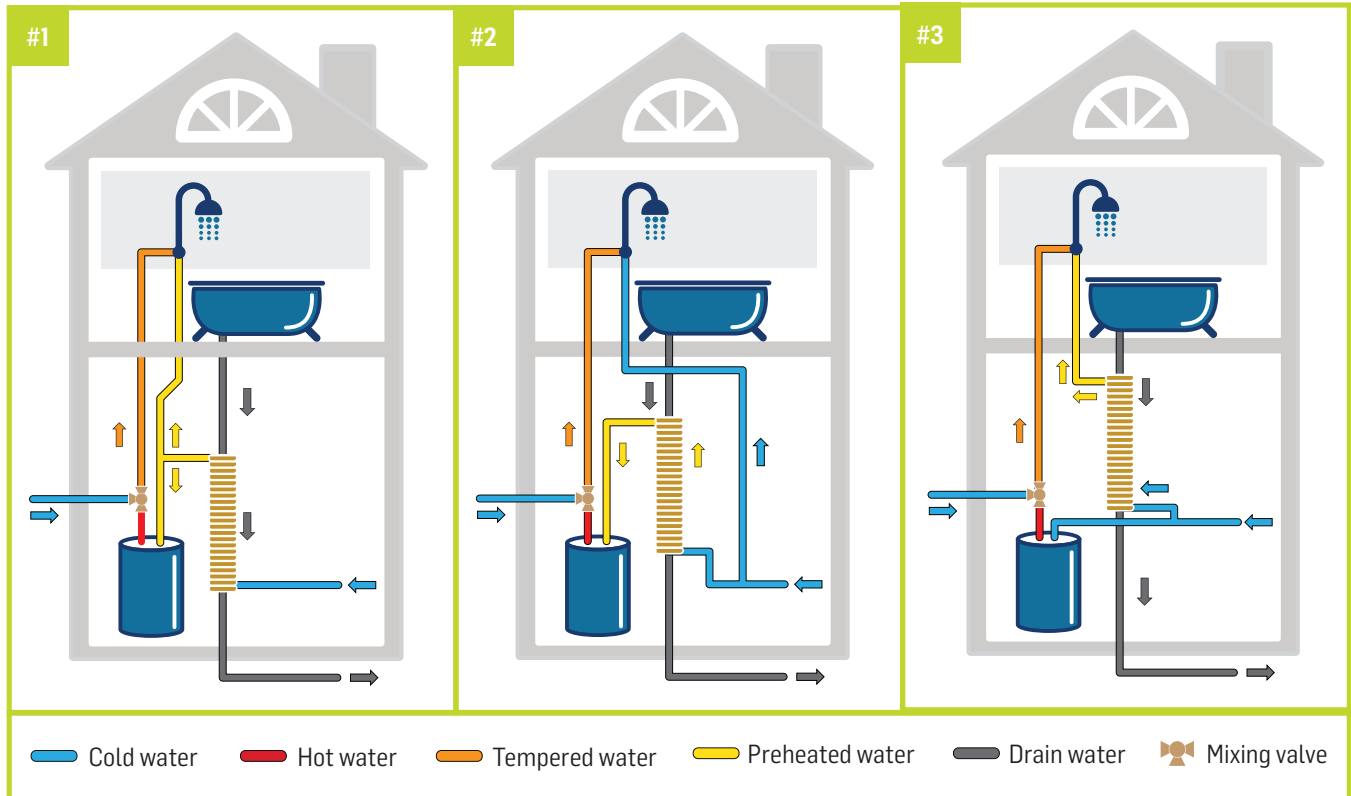

#1 - PREHEAT TO THE WATER HEATER AND SHOWER (Equal flow)

The preheated water from the unit is fed to both the water heater cold inlet and the cold shower supply. The equal flow installation is the most efficient. Note: This configuration is NOT allowed in the province of Quebec.

#2 - PREHEAT TO THE WATER HEATER SUPPLY

The preheated water from the unit is fed to the water heater inlet ONLY. This configuration is useful when access to plumbing is restricted or based on the plumbing system layout. Efficiency will be slightly lower than that of configuration #1.

#3 - PREHEAT TO THE SHOWER COLD WATER SUPPLY

The preheated water from the unit is fed to the cold shower side ONLY. This configuration is useful when access to plumbing is restricted or based on the plumbing system layout. Efficiency will be slightly lower than that of configuration #1. Note: This configuration is NOT allowed in the province of Quebec.

INSTALLATION WITH TWO (2) SHOWERS

If two showers use a common drain stack apply any of the above configurations #1 to #3.

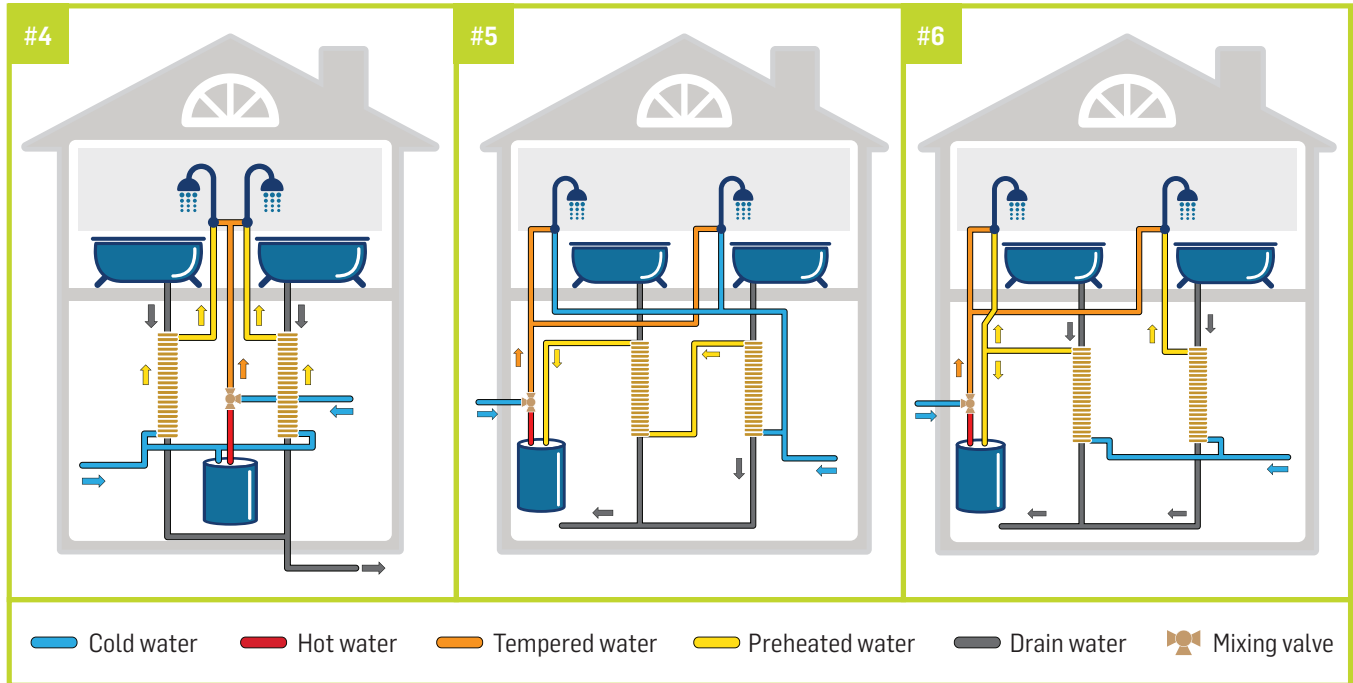

#4 - PREHEAT TO THE SHOWER COLD WATER SUPPLY

If two showers on the same or different levels use separate drain stacks the preheated water from the units is fed to each cold water side ONLY. Note: This configuration is NOT allowed in the province of Quebec.

#5 - PREHEAT TO THE WATER HEATER SUPPLY

If two showers on the same or different levels use separate drain stacks the preheated water from the units is fed to the water heater cold inlet ONLY. This configuration is useful when access to plumbing is restricted or based on the plumbing system layout.

#6 - HYBRID PREHEAT

This is a hybrid configuration between #4 & #5 that allows for easy installation in larger homes. Note: This configuration is NOT allowed in the province of Quebec.

LIMITED WARRANTY

EcolInnovation Technologies Inc. pays special attention to the design and delivery of its products. When the product is used for its intended purpose (standard residential/commercial plumbing system, standard operating temperature and pressure, in contact with non-caustic, non-corrosive and low mineral content drain water) the manufacturer offers a limited non-transferable warranty of five (5) years on all products against manufacturer defects from the date of purchase. The accessories manufactured by a third party and supplied with the ThermoDrain™ are covered by their respective manufacturer warranties and are not covered by the above EcolInnovation Technologies Inc. warranty. EcolInnovation Technologies Inc. assumes no responsibility with regards to these components.

If during the warranty period, a defect due to manufacturing or workmanship occurs that is covered by this warranty, EcolInnovation Technologies Inc. will proceed, entirely at its discretion, with the repair or replacement of the defective unit. Since the installation and use of the ThermoDrain™ are outside of the control of EcolInnovation Technologies Inc., no warranty is offered by the manufacturer for problems resulting from installation. It is the responsibility of the purchaser to properly select the product and to ensure that the product and installation procedures conform to local laws and codes in effect.

In no case is EcolInnovation Technologies Inc. responsible for prejudice to material, direct or indirect or as an accessory to other damages and/or expenses accrued, even if foreseeable, and even where resulting from the confirmed failure or the apparent or defect known by the purchaser, of all products or accessories distributed or sold by EcolInnovation Technologies Inc. In no case is EcolInnovation Technologies Inc. responsible for premature wear of its products due to the properties of the products used in conjunction with its products. It is the purchaser's responsibility to ensure that the products used in conjunction with the ThermoDrain™ are compatible with its specified intended design and use. The warranty in this document is non-transferable. The warranty will not be honored if the original serial number assigned by EcolInnovation Technologies Inc. is not legible or has been removed or has worn away with time. EcolInnovation Technologies does not offer any warranty on the optional components, other than those installed during manufacture of the ThermoDrain™.

This warranty does not cover defects caused by damage in transit, abuse, accident, negligence or repairs made by others. In the case of a defective product, contact the reseller in your area where you originally purchased the unit. All repairs or modifications made without the specific written authorization of EcolInnovation Technologies Inc. will render this warranty void without prejudice against EcolInnovation Technologies Inc.

6 - RECOVERY CALCULATION

It is assumed for the following calculations that the drain flow, drain temperature, initial cold water temperature and initial hot temperature are constant.

Required variables:

Variable	Measurement unit	Meaning
Qd	L/min	Drain flow
Qp	L/min	Flow rate of the preheated cold water exiting the ThermoDrain™
Qh	L/min	Flow rate of the hot water exiting the hot water tank
Tci	°C	Temperature of incoming cold water
Tco	°C	Temperature of preheated water exiting ThermoDrain™
Td	°C	Temperature of drain water entering the ThermoDrain™
Th	°C	Temperature of water exiting the hot water heater
ε	%	Efficiency
P	kW	Power

The ThermoDrain™ data sheets contain the necessary information required to perform calculations.

Considering the flow rate of the water circulating in the drain and the cold section we can establish two distinct cases:

- ▶ Equal flow rates between the drain and the cold water side
- ▶ Unequal flow rates between the drain and the cold water side

6.1 - CALCULATING THE PREHEATING OF HOT AND COLD WATER

In the first case where the flow rates are equal in the drain and the cold-water side, the calculation is relatively simple and characterized by:

- ▶ Constant temperature of the preheated cold water exiting the heat exchanger
- ▶ Constant efficiency of the heat exchanger

The temperature of the preheated water exiting the ThermoDrain™ is given by the following equation according to the effectiveness of the exchanger at the established flow:

$$T_{co} = \epsilon(T_d - T_{ci}) + T_{ci} \quad (1)$$

Knowing the drain flow as well as the temperature of cool water at the entry and the outlet side of the exchanger, calculate the recovered instantaneous power:

$$P = 0.07 Q_d(T_{co} - T_{ci}) \quad (2)$$

In the second case where there is unequal flow between the drain water and the cold water intake, the preheated water exiting the ThermoDrain™ can be distributed in one of the following configurations:

- ▶ To the cold inlet of the plumbing fixtures only
- ▶ To the inlet of the water heater only

6.2 - CALCULATING THE PREHEATING OF COLD WATER ONLY

In the case where the flow rates between the drain water and cold water are unequal, the calculation is more complex and is characterized by:

- ▶ A direct effect of the flow rate of the preheated water on the exit temperature of this water, considering that the effectiveness of the exchanger is a function of the flow of cool water
- ▶ A necessary iterative calculation to determine the equilibrium point based on the operating characteristics of the exchanger according to the cold water flow at equilibrium

Knowing the flow rate within the drain is necessary to calculate the preheated water flow in the exchanger at the initial conditions where $T_{co} = T_{ci}$ with the following equation:

$$Q_p = Q_d(T_h - T_d) / (T_h - T_{co}) \quad (3)$$

Next, calculate the efficiency of the heat exchanger for this cold side flow rate and the new exiting temperature T_{co} using equation (1) and the new required flow rate Q_p with equation (3). By iteration, recalculate T_{co} and Q_p until equilibrium is reached where the temperature T_{co} and the flow Q_p are constant. Calculate the instantaneous power recovered with equation (2).

Note that this configuration is sensitive to temperature variations in the drain water. It is not recommended to connect other plumbing fixtures to this drain to ensure the comfort of the users. A thermostatic valve can be used to limit this effect.

6.3 - CALCULATING THE PREHEATING OF HOT WATER ONLY

In the case where the flow rates are unequal between the drain and the cold water, the calculation is relatively simple and characterized by:

- ▶ Constant flow in the drain and in the incoming cold water
- ▶ Constant temperature of the preheated cold water exiting the heat exchanger
- ▶ Constant efficiency of the heat exchanger

Determine the flow rate Q_h that is equal to the flow rate from the hot water heater with equation (3) where:

$$Q_h = Q_d - Q_p \text{ with } T_{co} = T_{ci} \quad (4)$$

Next, calculate the preheated water temperature T_{co} with equation (1) considering the efficiency of the heat exchanger at flow rate Q_p et Q_d . Determine the instantaneous power recovered using equation (2).

Note that in this configuration, the drain temperature does not influence the comfort of the user.

7 - SYSTEM DESIGN

The ThermoDrain™ heat exchanger is capable of recovering a large quantity of energy. Many external factors directly influence its capacity to recover heat. The following points must be taken into consideration:

- ▶ The efficiency of the heat exchangers published by EcoInnovation Technologies has been measured in a laboratory to ensure accuracy of these results. These figures, however, are the efficiency of the heat exchanger alone and can be affected by the peculiarities in the plumbing system where it may be installed.
- ▶ The capacity of water heat recovery is a direct function of the frequency and the time of usage of the heat exchanger (combined usage of cold and hot water).
- ▶ The heat recovery unit must receive warm drain water to recover the energy within this drain water. The average temperature of the drain water that flows through the ThermoDrain™ must be evaluated for a combination of conditions expected, including the case where more than one source of drain water is added to the system.
- ▶ The temperature difference between the cold water and the drain water will determine the recovery potential. The higher the delta T, the more energy can be extracted.
- ▶ It is important to note that losses of heat associated with plumbing devices, pipes and other components within the plumbing system are to be considered. An evaluation of these losses will permit better prediction of the system performance.
- ▶ The ThermoDrain™ has a copper coil that can reach great lengths. It is expected that a pressure loss will be present. The pressure loss published by EcoInnovation Technologies has been obtained through laboratory tests. It is essential to measure the impact of these pressure drops in the design phase of the plumbing system, in particular when the cold water sections are placed in series with more than one heat exchanger.
- ▶ There exist many possible configurations of exchangers in a plumbing system, each of which has its own characteristics and affects heat recovery results. The expected performance of the heat exchangers and their influence on the system vary directly with the installation configuration chosen.
- ▶ EcoInnovation Technologies does not perform plumbing system design. Recommendations proposed by EcoInnovation Technologies are for evaluation purposes only, and we do not assume any responsibility for a design carried out by a third party.

8 - SPECIFICATION SHEETS

8.1 - TD SERIES 3" DRAIN DIAMETER

The ThermoDrain™ is the latest technology in Drain Water Heat Recovery. Its unique design provides outstanding savings that can be attributed to its superior performance and durability. With its exclusive features, the ThermoDrain™ is simply the best technology available today!

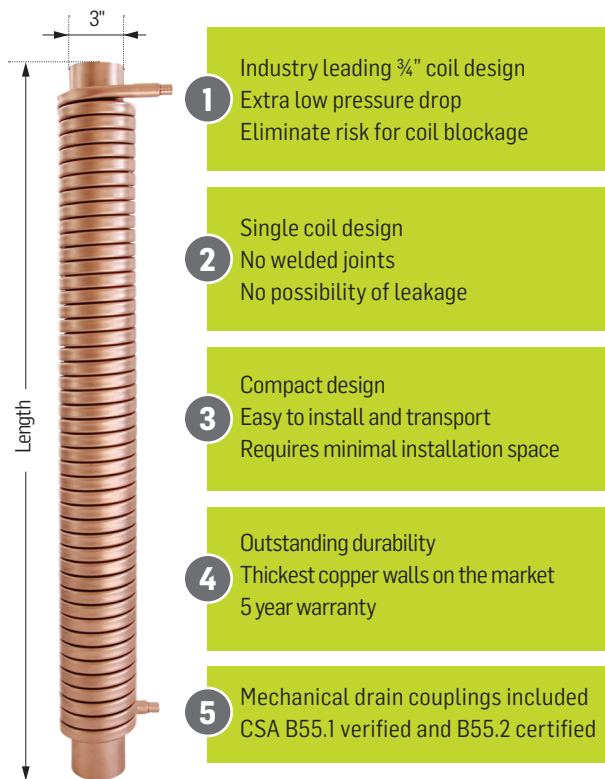

- 1 Industry leading 3/4" coil design
Extra low pressure drop
Eliminate risk for coil blockage
- 2 Single coil design
No welded joints
No possibility of leakage
- 3 Compact design
Easy to install and transport
Requires minimal installation space
- 4 Outstanding durability
Thickest copper walls on the market
5 year warranty
- 5 Mechanical drain couplings included
CSA B55.1 verified and B55.2 certified



TECHNICAL CHARACTERISTICS

- Potable water tube: Made from Type "L" copper, certified to ASTM B88;
- Minimal copper coil diameter is 3/4", profiled in a "D" shape to maximize heat transfer and minimize pressure drop;
- Approved maximum pressure rating of 150psi (1035 kPa);
- Potable water connections are the required diameter to connect to the water feed for the application. [Standard diameters: 3/4", 1", 1 1/4", 1 1/2".]

DRAIN CENTER TUBE

- Made from DWV copper, conforms to ASTM 306;
- The nominal diameter is the same as the drainage pipe on which the device is installed. [Standard diameters: 3" and 4".]

CERTIFICATIONS

- The length of the heat exchanger is accordance with engineering drawings. [Standard length: 12" to 100".]
- The thermal effectiveness of the heat exchanger must be verified to CSA B55.1-15. [All models]
- The construction of the heat exchanger must be certified to CSA B55.2-15. [All models]
- Three potable water connection options are available:
 - factory installed crimp PEX fittings, certified to CSA B137.5 and ASTM F1807
 - factory installed cold expansion PEX fittings, certified to ASTM F1960
 - 3/4" male copper tubing

INSTALLATION

The drain water heat exchanger will be integrated into the plumbing system using mechanical joints. The heat recovery unit will be installed vertically, as recommended by the manufacturer.

ACCEPTED PRODUCT

ThermoDrain models TDXXXB from EcoInnovation Technologies inc. [See technical drawing sheet].

TD series 3" drain diameter



Intertek Test Data Sheets

Page 7 of 8

Original Test Data

Client: ECO Innovations Technology Inc. Engineer: Blaine Serio *BS*
 Job No.: G101070334 Tested By: Pocholo Laforteza *PL* Date: 24-April-2013
 Product: Drain Water Heat Recovery Pipe Reviewed By: *Mr. M. H. P.* Rick Curkeet Date: June 17th, 2013
 Model No.: TD336B, TD342B, TD348B, TD360B, TD372 Standard(s): CSA B55.1 Issued: 2012/07/01 Test Method for Measuring Efficiency and Pressure Loss of Drain Water Heat Recovery Units
 Sample Control Number(s): 134000131, 134000129, 134000126, 134000119, 134000120

Model Number	Diameter (in)	Diameter (mm)	Length (in)	Length (mm)	Calculated Efficiency (%) @ 9.5 L/min	Calculated Pressure Loss (psi) @ 9.5 L/min	Heat Recover (kW)	Pressure Loss (kPa)	Mass (kg)
TD336B	3	76.2	36	914.4	39.2%	1.3	7.0	9.1	10.0
TD338B	3	76.2	38	965.2	40.4%	1.4	7.2	9.7	10.4
TD340B	3	76.2	40	1016	41.6%	1.5	7.5	10.3	10.9
TD342B	3	76.2	42	1066.8	42.8%	1.6	7.7	10.9	11.2
TD344B	3	76.2	44	1117.6	43.9%	1.7	7.9	11.5	11.9
TD346B	3	76.2	46	1168.4	45.0%	1.8	8.1	12.1	12.4
TD348B	3	76.2	48	1219.2	46.0%	1.8	8.2	12.7	13.0
TD350B	3	76.2	50	1270	47.0%	1.9	8.4	13.3	13.4
TD352B	3	76.2	52	1320.8	48.0%	2.0	8.6	13.9	14.0
TD354B	3	76.2	54	1371.6	48.9%	2.1	8.8	14.5	14.6
TD356B	3	76.2	56	1422.4	49.8%	2.2	8.9	15.0	15.2
TD358B	3	76.2	58	1473.2	50.7%	2.3	9.1	15.6	15.8
TD360B	3	76.2	60	1524	51.5%	2.3	9.2	16.2	16.5
TD362B	3	76.2	62	1574.8	52.3%	2.4	9.4	16.7	17.0
TD364B	3	76.2	64	1625.6	53.0%	2.5	9.5	17.3	17.7
TD366B	3	76.2	66	1676.4	53.7%	2.6	9.6	17.8	18.3
TD368B	3	76.2	68	1727.2	54.4%	2.7	9.7	18.4	18.9
TD370B	3	76.2	70	1778	55.0%	2.7	9.9	18.9	19.6
TD372B	3	76.2	72	1828.8	55.6%	2.8	10.0	19.5	20.3

TD series 3" drain diameter Efficiency vs water flow rate

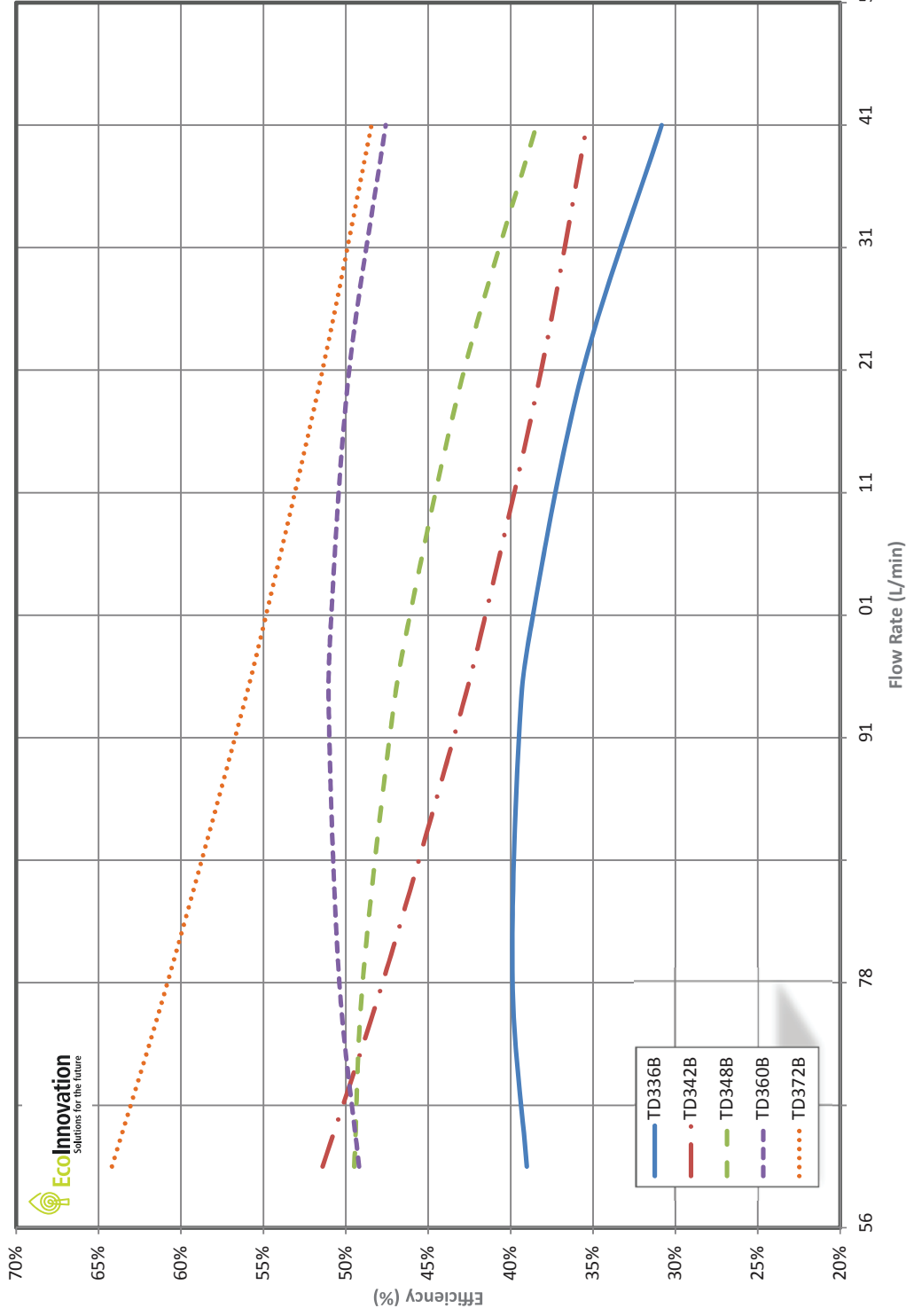

TD series 3" drain diameter

Recovered energy vs water flow rate

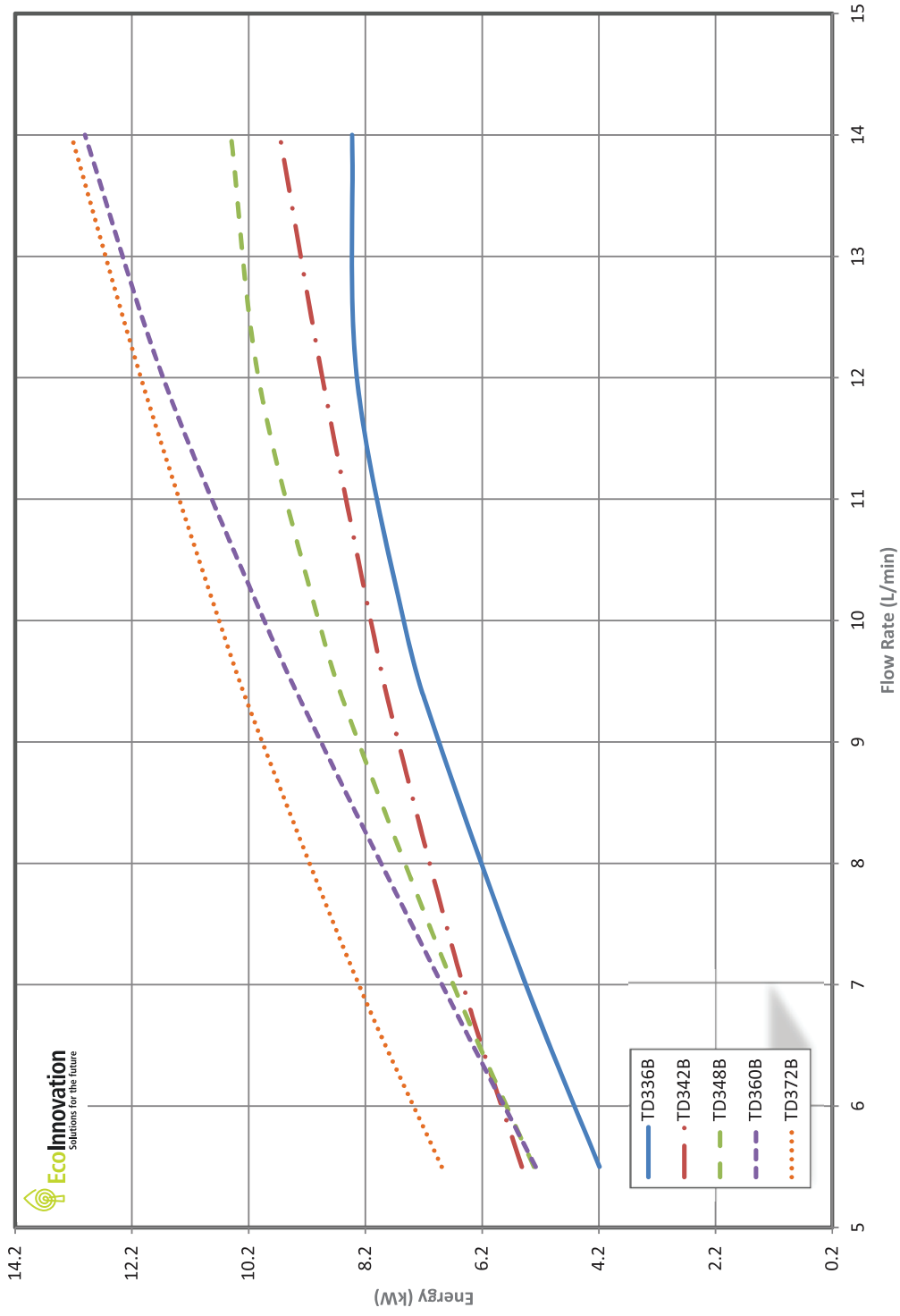

TD series 3" drain diameter

Pressure drop vs water flow rate

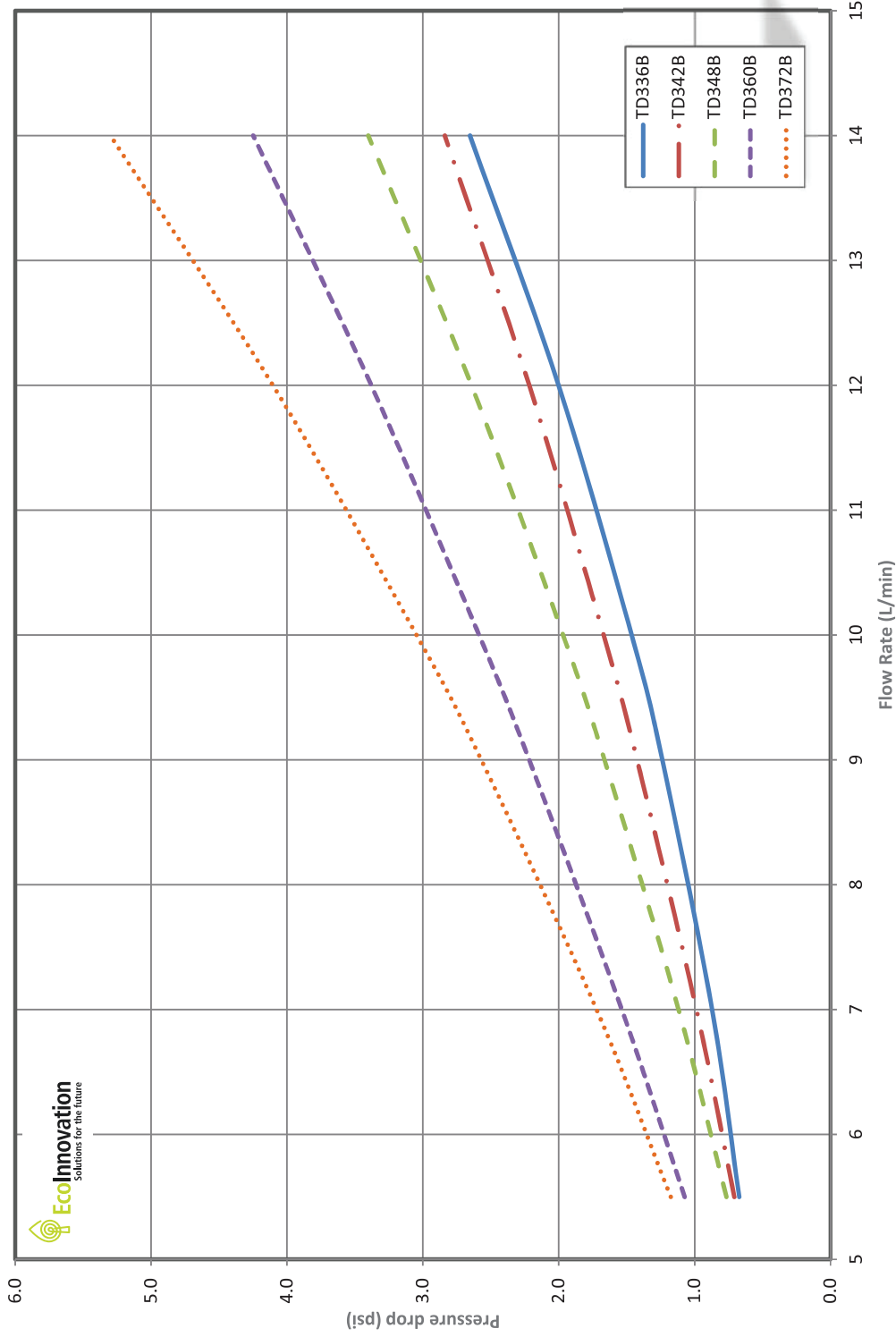

TD series 3" drain diameter

MODEL/MODELE : TDH		3		B	
SERIES/SÉRIE		DRAIN DIA.	LENGTH/LONG. "L"	TUBE DIA.	OPTIONS
		3"	32,0" - 62,0"	B = 3/4" CU	- DEFAULT MALE CU DR=W/ DRAIN COUPLINGS PEX=3/4" F1807 PEX EXP=3/4" F1960 PEX

SEE/VOIR Note A

NOTES:

- 1-THE DRAIN SECTION IS MADE FROM "COPPER DRAINAGE TUBE DWV" ASTM 306
- 1-LA SECTION DE DRAINAGE EST COMPOSÉE D'UN TUBE "COPPER DRAINAGE TUBE DWV" ASTM 306 EN CUIVRE
- 2-THE POTABLE WATER COIL IS MADE FROM TYPE "L" "SEAMLESS COPPER WATER TUBE" ASTM B-88
- 2-LA SECTION D'EAU POTABLE EST COMPOSÉE DE TUBE TYPE "L" "SEAMLESS COPPER WATER TUBE" ASTM B-88 EN CUIVRE
- 3-PEX FITTING IS CSA B137.5 AND ASTM F1807
- 3-RACCORD PEX CSA B137.5 ET ASTM F1807
- 4-UNIT MUST BE INSTALLED VERTICALLY. MAX. ALLOWANCE IS 1/8" PER LINEAR FEET.
- 4-L'INSTALLATION DOIT SE FAIRE DE MANIÈRE À CE QUE L'UNITÉ SOIT DANS UNE PENTE MAXIMALE DE 1/8" PAR PIED LINÉAIRE DE LA VERTICALE
- 5-GENERAL TOLERANCES ±1/4"
- 5-TOLÉRANCES GÉNÉRALES ±1/4"
- A-32" TO 62" IN LENGTH ARE CSA B55.1 EFFICIENCY VERIFIED
- INDICATE OTHER LENGTH AS REQUIRED: 12" to 72" AVAILABLE
- USE 3 DIGITS FOR LENGTH IN 0.5" INCREMENTS
- A-32" À 62" À 0,5" DE LONGUEUR EFFICACITÉS VÉRIFIÉES SELON CSA B55.1
- LONGUEURS DISPONIBLES SUR MESURE: 12" À 72"
- UTILISER 3 CHIFFRES POUR LA LONGUEUR EN INCREMENTS DE 0.5"

PROJECT / PROJET:		DATE:
APP:		
ECONNOVATION TECHNOLOGIES INC. 231 RUE STE MARIE, QUÉBEC, Q.C. J0S 1T0 T: 1-888-899-1133 F: 1-888-899-1135		
REV	DATE	BY/PAR
1	March 20'	MF
TITLE:		TITLE:
SHOP DRAWING		
DESSIN D'ATELIER		
DRAWING NO.: THERMODRAIN TDH SERIES		DESIGN NO.:
REV	DATE	BY/PAR
1:8	01/01/20	1
		1/1

8.2 - TD SERIES 4" DRAIN DIAMETER

The ThermoDrain™ is the latest technology in Drain Water Heat Recovery. Its unique design provides outstanding savings that can be attributed to its superior performance and durability. With its exclusive features, the ThermoDrain™ is simply the best technology available today!

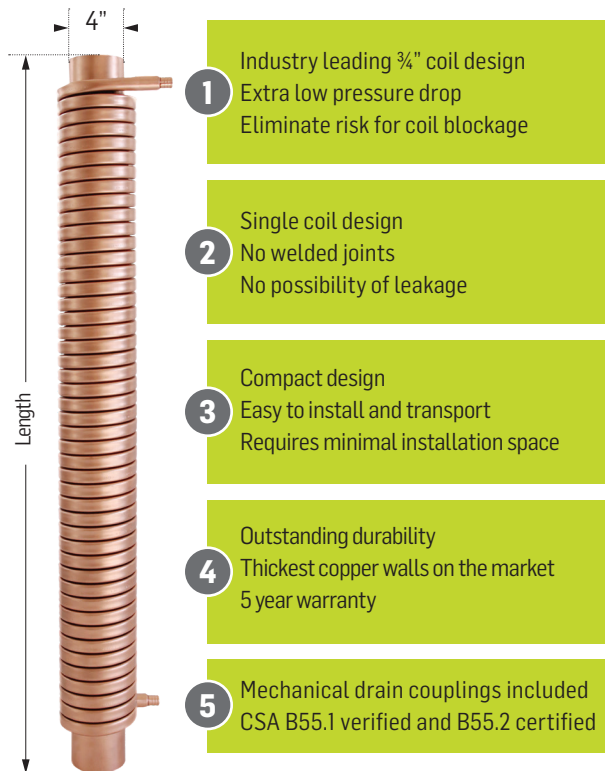

- 1 Industry leading 3/4" coil design
Extra low pressure drop
Eliminate risk for coil blockage
- 2 Single coil design
No welded joints
No possibility of leakage
- 3 Compact design
Easy to install and transport
Requires minimal installation space
- 4 Outstanding durability
Thickest copper walls on the market
5 year warranty
- 5 Mechanical drain couplings included
CSA B55.1 verified and B55.2 certified



TECHNICAL CHARACTERISTICS

- Potable water tube: Made from Type "L" copper, certified to ASTM B88;
- Minimal copper coil diameter is 3/4", profiled in a "D" shape to maximize heat transfer and minimize pressure drop;
- Approved maximum pressure rating of 150psi (1035 kPa);
- Potable water connections are the required diameter to connect to the water feed for the application. [Standard diameters: 3/4", 1", 1 1/4", 1 1/2".]

DRAIN CENTER TUBE

- Made from DWV copper, conforms to ASTM 306;
- The nominal diameter is the same as the drainage pipe on which the device is installed. [Standard diameters: 3" and 4".]

CERTIFICATIONS

- The length of the heat exchanger is accordance with engineering drawings. [Standard length: 12" to 100".]
- The thermal effectiveness of the heat exchanger must be verified to CSA B55.1-15. [All models]
- The construction of the heat exchanger must be certified to CSA B55.2-15. [All models]
- Three potable water connection options are available:
 - factory installed crimp PEX fittings, certified to CSA B137.5 and ASTM F1807
 - factory installed cold expansion PEX fittings, certified to ASTM F1960
 - 3/4" male copper tubing

INSTALLATION

The drain water heat exchanger will be integrated into the plumbing system using mechanical joints. The heat recovery unit will be installed vertically, as recommended by the manufacturer.

ACCEPTED PRODUCT

ThermoDrain models TDXXXB from EcoInnovation Technologies inc. [See technical drawing sheet].

TD series 4" drain diameter



Intertek Test Data Sheets Original Test Data

Page 5 of 6

Client: ECO Innovations Technology Inc. Engineer: Blaine Serio
 Job No.: G101070334 Tested By: Pocholo Laforteza Date: 29-April-2013
 Product: Drain Water Heat Recovery Pipe Reviewed By: Rick Curkeet Date: June 17th, 2013
 Model No.: TD442B, TD460B,, TD472B Standard(s): CSA B55.1 Issued: 2012/07/01 Test Method for Measuring Efficiency and Pressure Loss of Drain Water Heat Recovery Units
 Sample Control Number(s): 134000121, 134000122, 134000123

Model Number	Diameter (in)	Diameter (mm)	Length (in)	Length (mm)	Calculated Efficiency (%) @ 9.5 L/min	Calculated Pressure Loss (psi) @ 9.5 L/min	Heat Recover (kW)	Pressure Loss (kPa)	Mass (kg)
TD442B	4	101.6	42	1066.8	46.0%	1.4	8.3	9.6	16.8
TD460B	4	101.6	60	1524	57.3%	2.2	10.3	15.4	24.8
TD472B	4	101.6	72	1828.8	58.4%	2.7	10.5	18.5	29.9

TD series 4" drain diameter *Efficiency vs water flow rate*

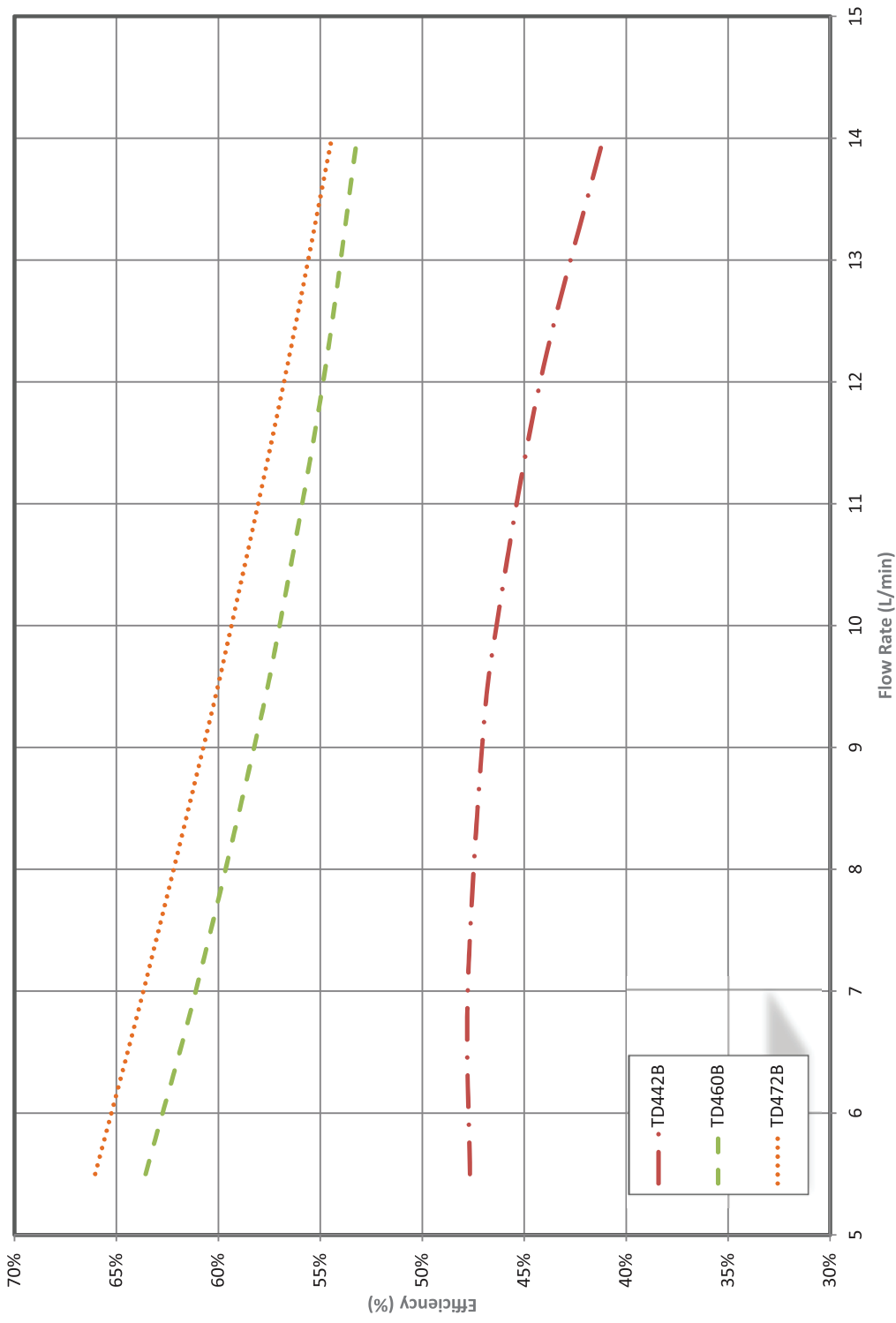

TD series 4" drain diameter

Recovered energy vs water flow rate

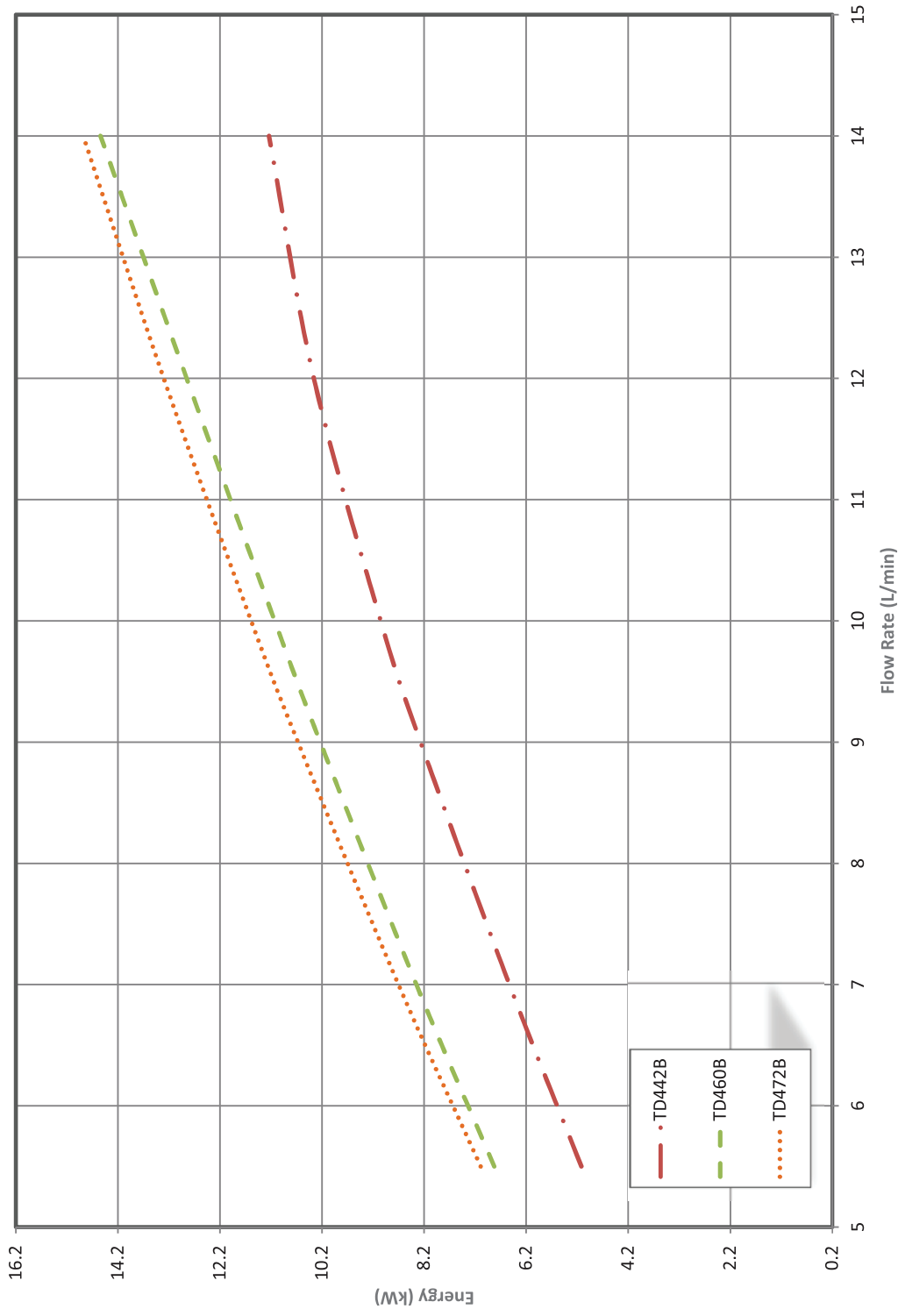

TD series 4" drain diameter

Pressure drop vs water flow rate

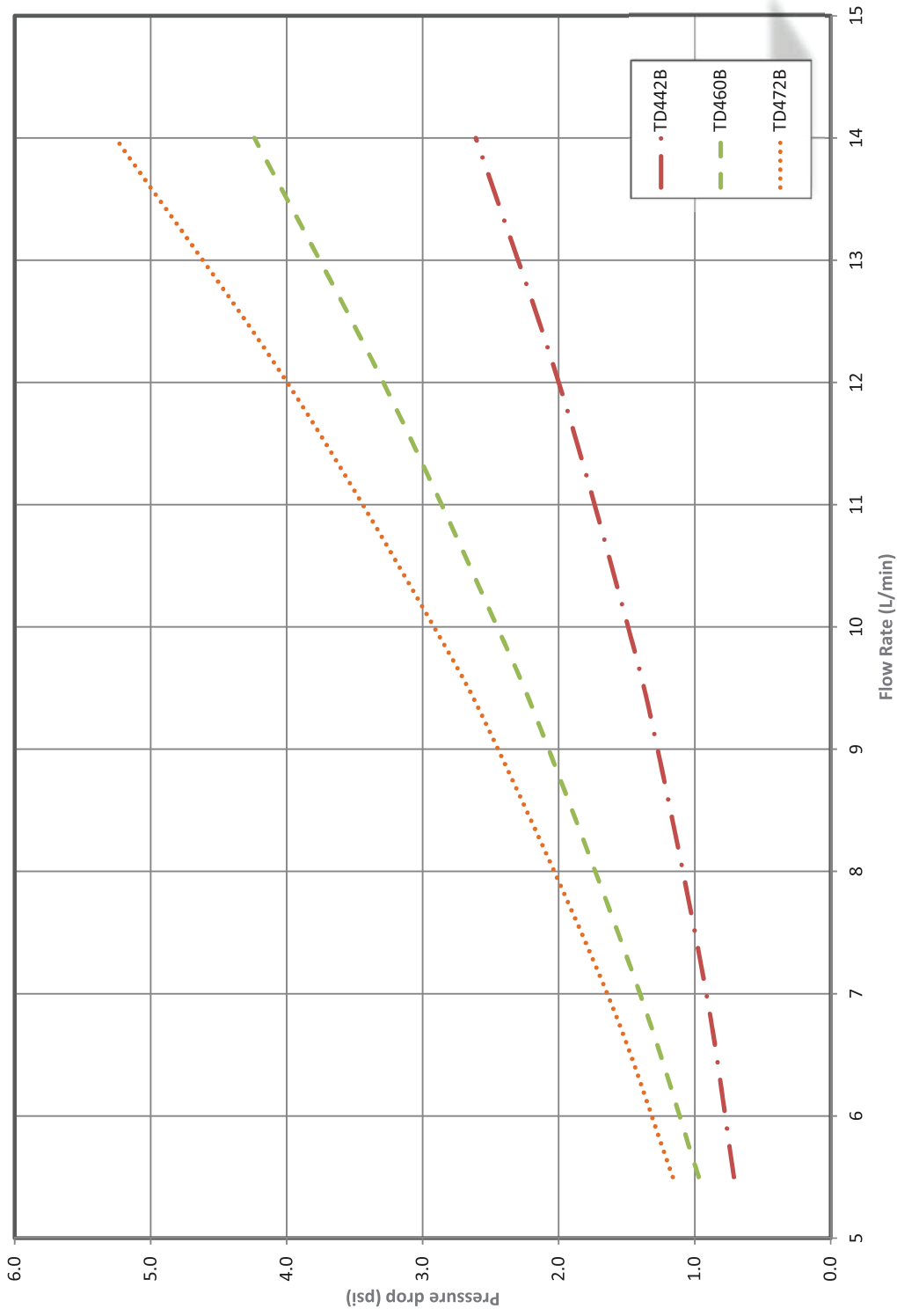

TD series 4" drain diameter

MODEL/MODELE : TDH		3		B	
SERIES/SÉRIE		DRAIN DIA.	LENGTH/LONG. "L"	TUBE DIA.	OPTIONS
		3"	32,0" - 62,0"	B = 3/4" CU	- DEFAULT MALE CU DR=W/ DRAIN COUPLINGS PEX=3/4" F1807 PEX EXP=3/4" F1960 PEX
SEE/VOIR Note A					

NOTES:

1-THE DRAIN SECTION IS MADE FROM "COPPER DRAINAGE TUBE DWV" ASTM 306
1-LA SECTION DE DRAINAGE EST COMPOSÉE D'UN TUBE "COPPER DRAINAGE TUBE DWV" ASTM 306 EN CUIVRE

2-THE POTABLE WATER COIL IS MADE FROM TYPE "L" "SEAMLESS COPPER WATER TUBE" ASTM B-88
2-LA SECTION D'EAU POTABLE EST COMPOSÉE DE TUBE TYPE "L" "SEAMLESS COPPER WATER TUBE" ASTM B-88 EN CUIVRE

3-PEX FITTING IS CSA B137.5 AND ASTM F1807
3-RACCORD PEX CSA B137.5 ET ASTM F1807

4-UNIT MUST BE INSTALLED VERTICALLY. MAX. ALLOWANCE IS 1/8" PER LINEAR FEET.
4-L'INSTALLATION DOIT SE FAIRE DE MANIÈRE À CE QUE L'UNITÉ SOIT DANS UNE PENTE MAXIMALE DE 1/8" PAR PIED LINÉAIRE DE LA VERTICALE

5-TOLERANCES GÉNÉRALES ±1/4"

A-32" TO 62" IN LENGTH ARE CSA B55.1 EFFICIENCY VERIFIED
INDICATE OTHER LENGTH AS REQUIRED: 12" to 72" AVAILABLE
USE 3 DIGITS FOR LENGTH IN 0.5" INCREMENTS
A-32" À 62" À 0,5" DE LONGUEUR EFFICACITÉS VÉRIFIÉES SELON CSA B55.1
LONGUEURS DISPONIBLES SUR MESURE: 12" À 72"
UTILISER 3 CHIFFRES POUR LA LONGUEUR EN INCREMENTS DE 0.5"

PROJECT / PROJET:		DATE:	
APP: ECONOVATION TECHNOLOGIES INC. 231 RUE STE MARIE, QUÉBEC, Q.C. J0S 1T0 T: 1-888-899-1133 F: 1-888-899-1135			
REV	DATE	BY/PAR	TITLE
1	March 20'	Added F1960 PEX option	MF
		MODIFICATION	
DRAWING NO.: THERMODRAIN TDH SERIES		DESIGN NO.:	
REV	DATE	BY/PAR	TITLE
1:8	01/01/20		
1	1/1		



EcoInnovation
EcoInnovation Technologies Inc.

231 Rue Ste Marie
St-Louis de Gonzague (Qc) J0S 1T0

1.888.891.7693
1.888.899.1135
info@ecoinnovation.ca
www.ecoinnovation.ca

8.3 - TDH HIGH PERFORMANCE SERIES 3" DRAIN DIAMETER

The ThermoDrain™ TDH series is the latest technology in Drain Water Heat Recovery. Its unique compact design provides high efficiency and an easier installation. With its exclusive features, the ThermoDrain™ TDH series is simply the best technology available today!

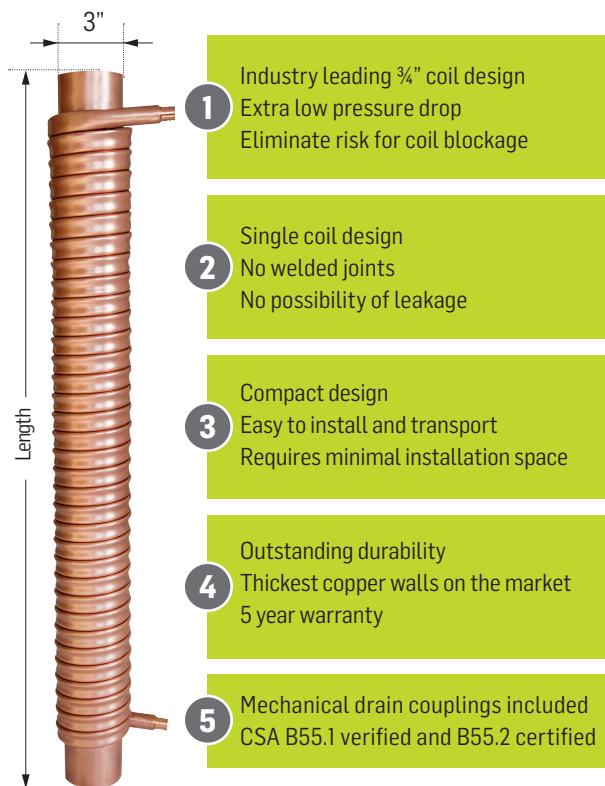

TECHNICAL CHARACTERISTICS

- Potable water tube: Made from Type "L" copper, certified to ASTM B88;
- Minimal copper coil diameter is 3/4", profiled in a "D" shape to maximize heat transfer and minimize pressure drop;
- Approved maximum pressure rating of 150psi (1035 kPa);
- Maximum recommended flow rate of 19 Lpm (5 Gpm)

DRAIN CENTER TUBE

- Made from DWV copper, conforms to ASTM 306;
- The nominal diameter is the same as the drainage pipe on which the device is installed. [Standard diameters: 3"]

CERTIFICATIONS

- The length of the heat exchanger is accordance with engineering drawings. Standard length: 32" to 62"
- The thermal effectiveness of the heat exchanger is verified to CSA B55.1-15. [All models]
- The construction of the heat exchanger is certified to CSA B55.2-15. [All models]
- Three potable water connection options are available:
 - factory installed crimp PEX fittings, certified to CSA B137.5 and ASTM F1807
 - factory installed cold expansion PEX fittings, certified to ASTM F1960
 - 3/4" male copper tubing

INSTALLATION

The drain water heat exchanger will be integrated into the plumbing system using mechanical joints. The heat recovery unit will be installed vertically, as recommended by the manufacturer.

ACCEPTED PRODUCT

ThermoDrain models TDH3XXXB from EcoInnovation Technologies inc. [See technical drawing sheet].

MODEL	LENGTH (in)	EFFICIENCY (%) at 9.5L/min (2.5 GPM)	PRESSURE LOSS (psi) at 9.5L/min (2.5 GPM)	HEAT RECOVERY (kW)	MASS (lbs)	MODEL	LENGTH (in)	EFFICIENCY (%) at 9.5L/min (2.5 GPM)	PRESSURE LOSS (psi) at 9.5L/min (2.5 GPM)	HEAT RECOVERY (kW)	MASS (lbs)
TDH3320B	32.0	41.0	2.0	7.7	15.4	TDH3475B	47.5	50.8	2.3	9.6	24.4
TDH3325B	32.5	41.4	2.0	7.8	15.7	TDH3480B	48.0	51.0	2.3	9.6	24.7
TDH3330B	33.0	41.8	2.0	7.9	16.0	TDH3485B	48.5	51.3	2.3	9.7	25.0
TDH3335B	33.5	42.1	2.1	7.9	16.3	TDH3490B	49.0	51.6	2.4	9.7	25.3
TDH3340B	34.0	42.5	2.1	8.0	16.6	TDH3495B	49.5	51.8	2.4	9.8	25.5
TDH3345B	34.5	42.8	2.1	8.1	16.9	TDH3500B	50.0	52.1	2.4	9.8	25.8
TDH3350B	35.0	43.2	2.1	8.1	17.2	TDH3505B	50.5	52.3	2.4	9.8	26.1
TDH3355B	35.5	43.5	2.1	8.2	17.5	TDH3510B	51.0	52.6	2.4	9.9	26.4
TDH3360B	36.0	43.8	2.2	8.3	17.8	TDH3515B	51.5	52.8	2.4	9.9	26.7
TDH3365B	36.5	44.2	2.1	8.3	18.1	TDH3520B	52.0	53.0	2.4	10.0	26.9
TDH3370B	37.0	44.5	2.1	8.4	18.4	TDH3525B	52.5	53.3	2.4	10.0	27.2
TDH3375B	37.5	44.8	2.2	8.5	18.7	TDH3530B	53.0	53.5	2.4	10.1	27.5
TDH3380B	38.0	45.2	2.2	8.5	18.9	TDH3535B	53.5	53.7	2.4	10.1	27.8
TDH3385B	38.5	45.5	2.2	8.6	19.2	TDH3540B	54.0	54.0	2.4	10.1	28.1
TDH3390B	39.0	45.8	2.2	8.6	19.5	TDH3545B	54.5	54.2	2.4	10.2	28.3
TDH3395B	39.5	46.1	2.2	8.7	19.8	TDH3550B	55.0	54.4	2.4	10.2	28.6
TDH3400B	40.0	46.4	2.2	8.8	20.1	TDH3555B	55.5	54.6	2.4	10.2	28.9
TDH3405B	40.5	46.8	2.2	8.8	20.4	TDH3560B	56.0	54.8	2.4	10.3	29.2
TDH3410B	41.0	47.1	2.2	8.9	20.7	TDH3565B	56.5	55.1	2.4	10.3	29.4
TDH3415B	41.5	47.4	2.2	8.9	21.0	TDH3570B	57.0	55.3	2.4	10.4	29.7
TDH3420B	42.0	47.7	2.2	9.0	21.3	TDH3575B	57.5	55.5	2.4	10.4	30.0
TDH3425B	42.5	48.0	2.3	9.0	21.6	TDH3580B	58.0	55.7	2.4	10.4	30.3
TDH3430B	43.0	48.3	2.3	9.1	21.8	TDH3585B	58.5	55.9	2.4	10.5	30.5
TDH3435B	43.5	48.6	2.3	9.2	22.1	TDH3590B	59.0	56.1	2.4	10.5	30.8
TDH3440B	44.0	48.8	2.3	9.2	22.4	TDH3595B	59.5	56.3	2.4	10.5	31.1
TDH3445B	44.5	49.1	2.3	9.3	22.7	TDH3600B	60.0	56.4	2.4	10.6	31.4
TDH3450B	45.0	49.4	2.3	9.4	23.0	TDH3605B	60.5	56.6	2.4	10.6	31.6
TDH3455B	45.5	49.7	2.3	9.4	23.3	TDH3610B	61.0	56.8	2.4	10.6	31.9
TDH3460B	46.0	50.0	2.3	9.5	23.6	TDH3615B	61.5	57.0	2.4	10.6	32.2
TDH3465B	46.5	50.2	2.3	9.5	23.8	TDH3620B	62.0	57.2	2.5	10.7	32.4
TDH3470B	47.0	50.5	2.3	9.5	24.1						

Note : All models have a 3" drain diameter

Efficiency vs. length

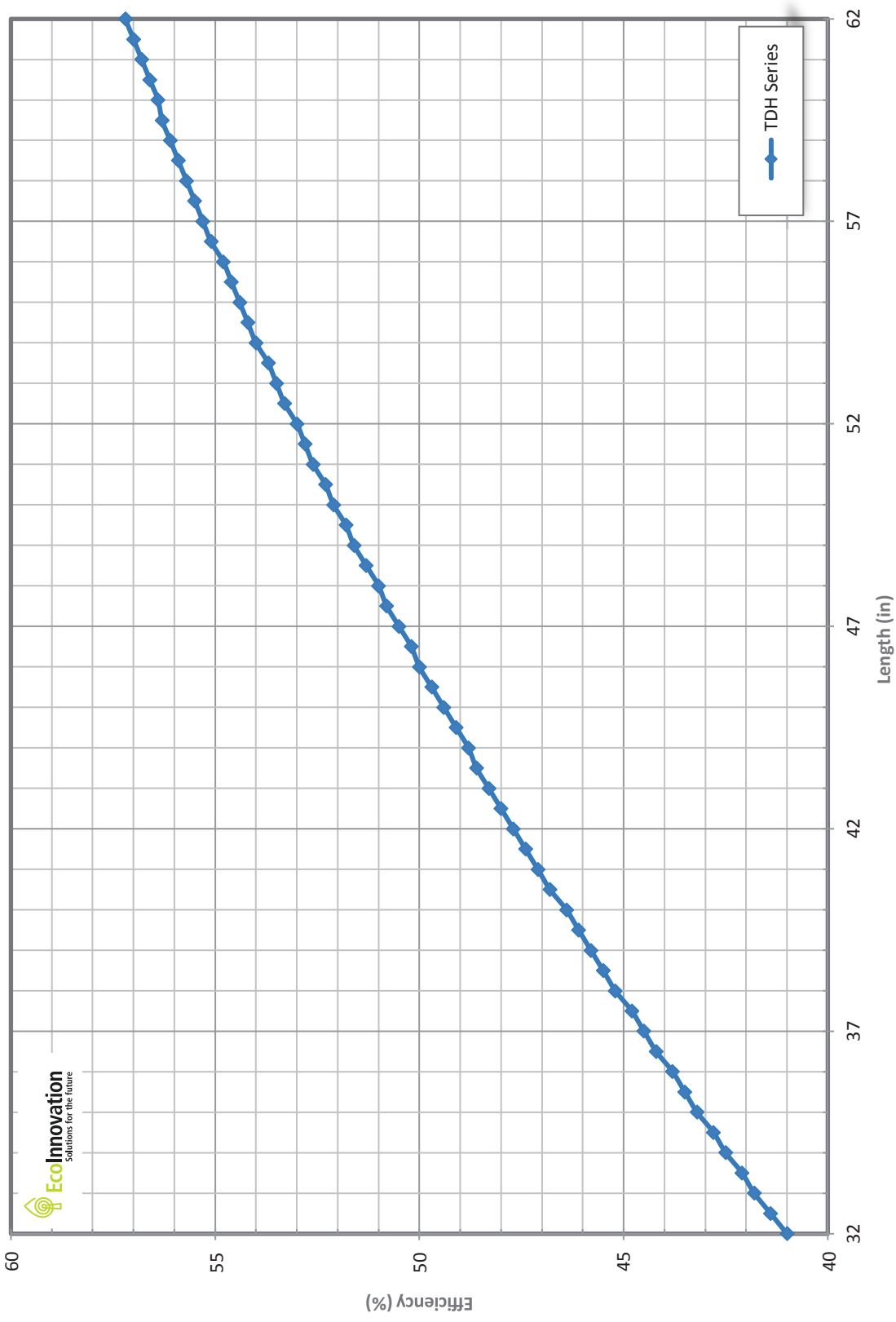

TDH high performance series 3" drain diameter

MODEL/MODELE : TDH		3	B	
SERIES/SÉRIE		DRAIN DIA.	LENGTH/LONG. "L"	TUBE DIA.
		3"	32,0" - 62,0"	B = 3/4" CU
SEE/VOIR Note A				
OPTIONS				
- DEFAULT MALE CU				
DR=W/ DRAIN COUPLINGS				
PEX=3/4" F1807 PEX				
EXP=3/4" F1960 PEX				

NOTES:

1-THE DRAIN SECTION IS MADE FROM "COPPER DRAINAGE TUBE DWV" ASTM 306
1-LA SECTION DE DRAINAGE EST COMPOSÉE D'UN TUBE "COPPER DRAINAGE TUBE DWV" ASTM 306 EN CUIVRE

2-THE POTABLE WATER COIL IS MADE FROM TYPE "L" "SEAMLESS COPPER WATER TUBE" ASTM B-88
2-LA SECTION D'EAU POTABLE EST COMPOSÉE DE TUBE TYPE "L" "SEAMLESS COPPER WATER TUBE" ASTM B-88 EN CUIVRE

3-PEX FITTING IS CSA B137.5 AND ASTM F1807
3-RACCORD PEX CSA B137.5 ET ASTM F1807

4-UNIT MUST BE INSTALLED VERTICALLY. MAX. ALLOWANCE IS 1/8" PER LINEAR FEET.
4-L'INSTALLATION DOIT SE FAIRE DE MANIÈRE À CE QUE L'UNITÉ SOIT DANS UNE PENTE MAXIMALE DE 1/8" PAR PIED LINÉAIRE DE LA VERTICALE

5-GENERAL TOLERANCES ±1/4"
5-TOLÉRANCES GÉNÉRALES ±1/4"

A-32" TO 62" IN LENGTH ARE CSA B55.1 EFFICIENCY VERIFIED
INDICATE OTHER LENGTH AS REQUIRED: 12" to 72" AVAILABLE
USE 3 DIGITS FOR LENGTH IN 0.5" INCREMENTS
A-32" À 62" À LONGUEUR EFFICACITÉ VÉRIFIÉE SELON CSA B55.1
LONGUEURS DISPONIBLES SUR MESURE: 12" À 72"
UTILISER 3 CHIFFRES POUR LA LONGUEUR EN INCRÉMENTS DE 0.5"

PROJECT / PROJET:		DATE:
APP:		ECOMMUNICATION TECHNOLOGIES INC.
231 RUE STE MARIE, ST-LOUIS DE GONZAGUE (QC) J0S 1T0		TÉL: 1-888-899-1133
REV 1		March 2017 Added F1960 PEX option
DATE	MODIFICATION	BY/PAR
TITLE:		
SHOP DRAWING		
DESSIN D'ATELIER		
DRAWING NO.: THERMODRAIN TDH SERIES		DESIGN NO.:
REV	DATE	BY
1	01/01/20	1
1/8		1/1

9 - SAMPLE IMAGES OF COMMERCIAL APPLICATIONS







