



WCW10

Cafe **DECO**

Single Burner Coffee Warmer



Cafe **DECO** Single Burner Coffee Warmer



MAIN FEATURES

- Keeps coffee fresh and hot
- Self regulating warmers prevent overheating – Saves energy compared to continuous heat models
- Low profile, simple design
- Stainless steel construction
- Non-skid feet
- Perfect for restaurants, cafes and diners
- Two-year parts and one year labor warranty

The Waring Coffee Warmers are best used in conjunction with Waring Commercial Coffee Makers, to ensure you always have hot and fresh coffee!



WCM50



WCM50P

Decanters not included with coffeemakers or warmer.

ELECTRICAL

Voltage: 120

Frequency: 60Hz

Watts: 70

Amps: 1.7

Plug Type: NEMA 5-15P ⓘ

Cord Length: 3 feet



SALES FEATURES

Perfect for restaurants, cafes, diners, and catered events, the Waring Commercial® Single Burner Coffee Warmer ensures there's always a fresh pot of piping hot coffee on hand. Durable yet lightweight, with wipe-clean stainless steel construction, it offers portable convenience and fits easily on any countertop. Just press the toggle switch on and the burner generates 70W of heating power to keep coffee at the optimal temperature. Non-skid feet keep the unit in place to prevent spills.



@waringcommercial

©2021 Waring Commercial
314 Ella T. Grasso Avenue, Torrington, CT 06790
Tel. 800-492-7464 • Fax 860-496-9008

waringcommercialproducts.com

WCW10



OPTIONAL ACCESSORIES



WCDB64 64-oz. Glass Decanter

DIMENSIONS

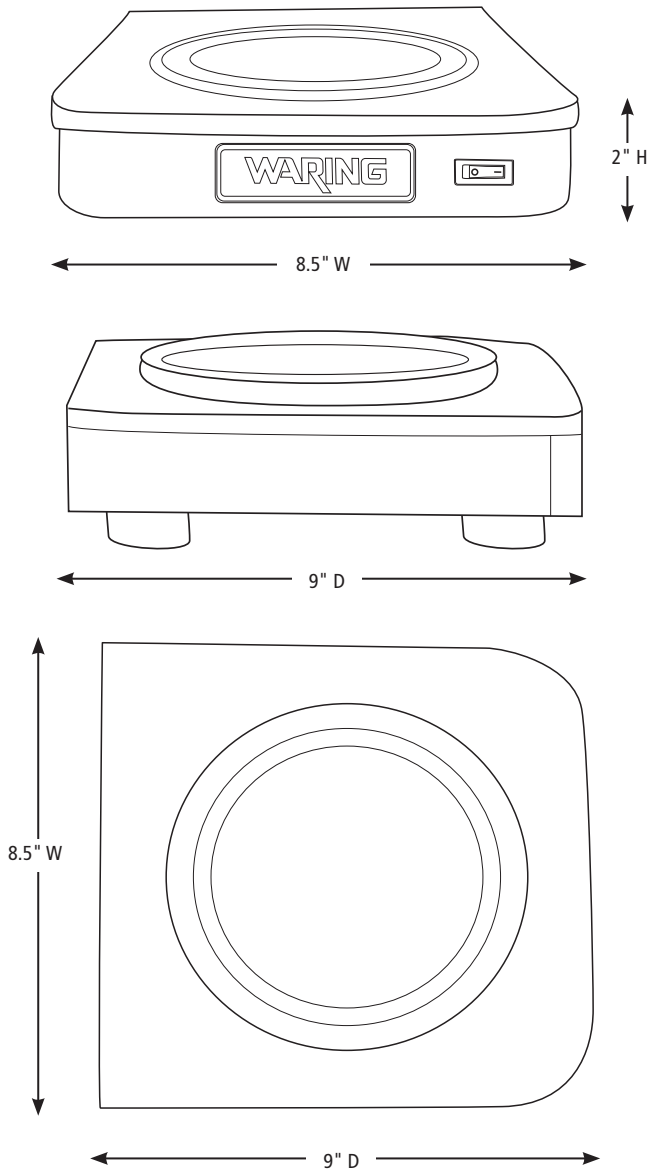

Out of Box Weight: 2 lb.

| ORDERING INFORMATION | #STD. PKG. | GIFTBOX WEIGHT | CUBIC FEET | BOX DIMENSIONS D X W X H | UPC | CASE PKG. | MC WEIGHT | MC DIMENSIONS D X W X H | MBC |
|-------------------------------------|------------|----------------|------------|----------------------------|--------------|-----------|-----------|-------------------------|----------------|
| WCW10 – Single Burner Coffee Warmer | 1 | 2.6 | 2.82 | 10.875" x 10.875" x 4.125" | 040072090707 | 16 | 45.2 | 22.25" x 22" x 17.75" | 10040072090704 |



@waringcommercial

©2021 Waring Commercial
314 Ella T. Grasso Avenue, Torrington, CT 06790
Tel. 800-492-7464 • Fax 860-496-9008

waringcommercialproducts.com

21WC081334 / REV 10/21