

WARING COMMERCIAL

Chamber Vacuum Sealer

WCV300

Unit Information

120 volts – 60 Hz – 380 watts
Effectively seals pouches up to 11" wide.
Seal Time: Max allowable time is 9 seconds.

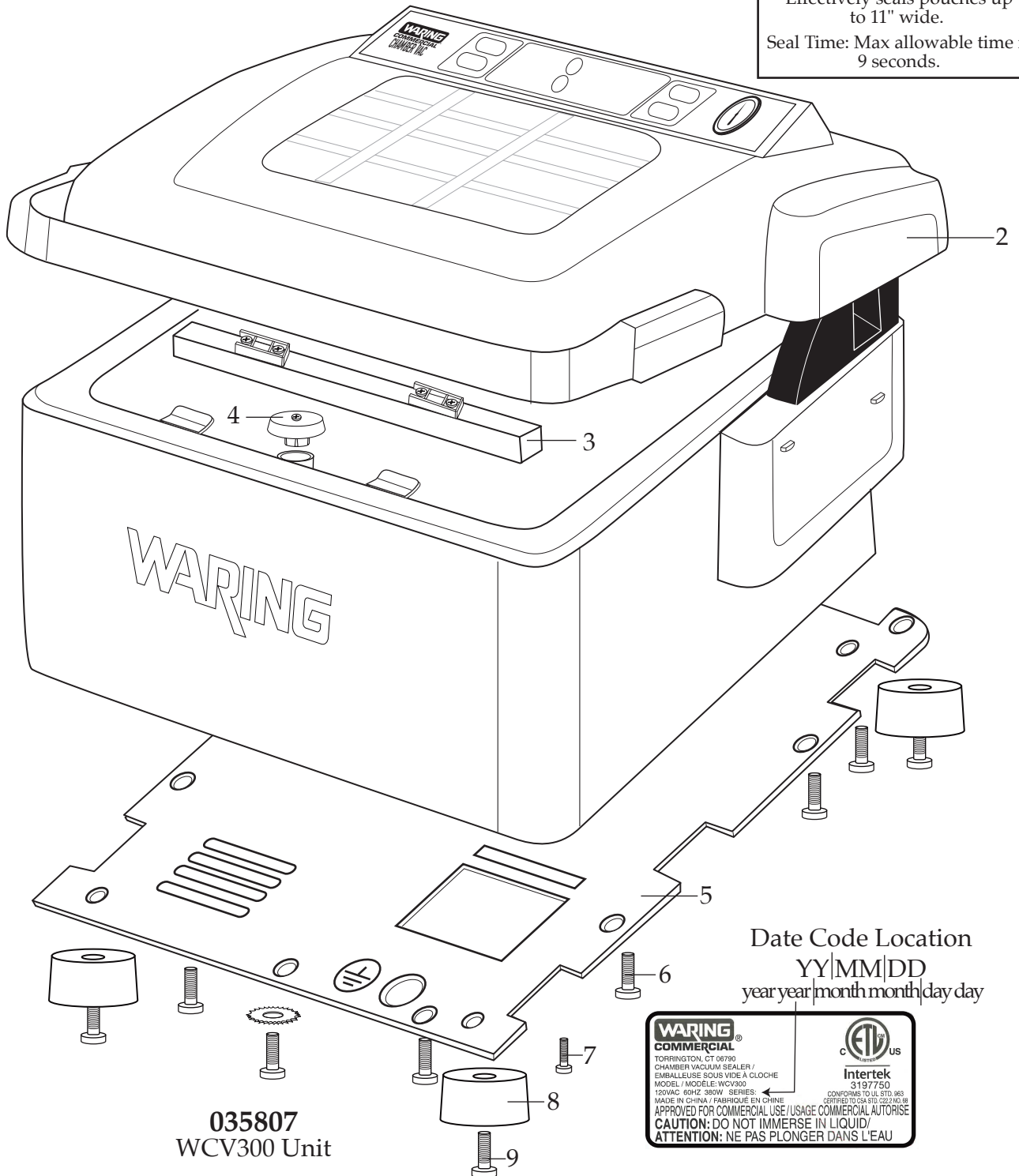

WARING

035807
WCV300 Unit

Date Code Location
YY|MM|DD
year|year|month|month|day|day



WARING COMMERCIAL[®] WCV300 Internal Parts

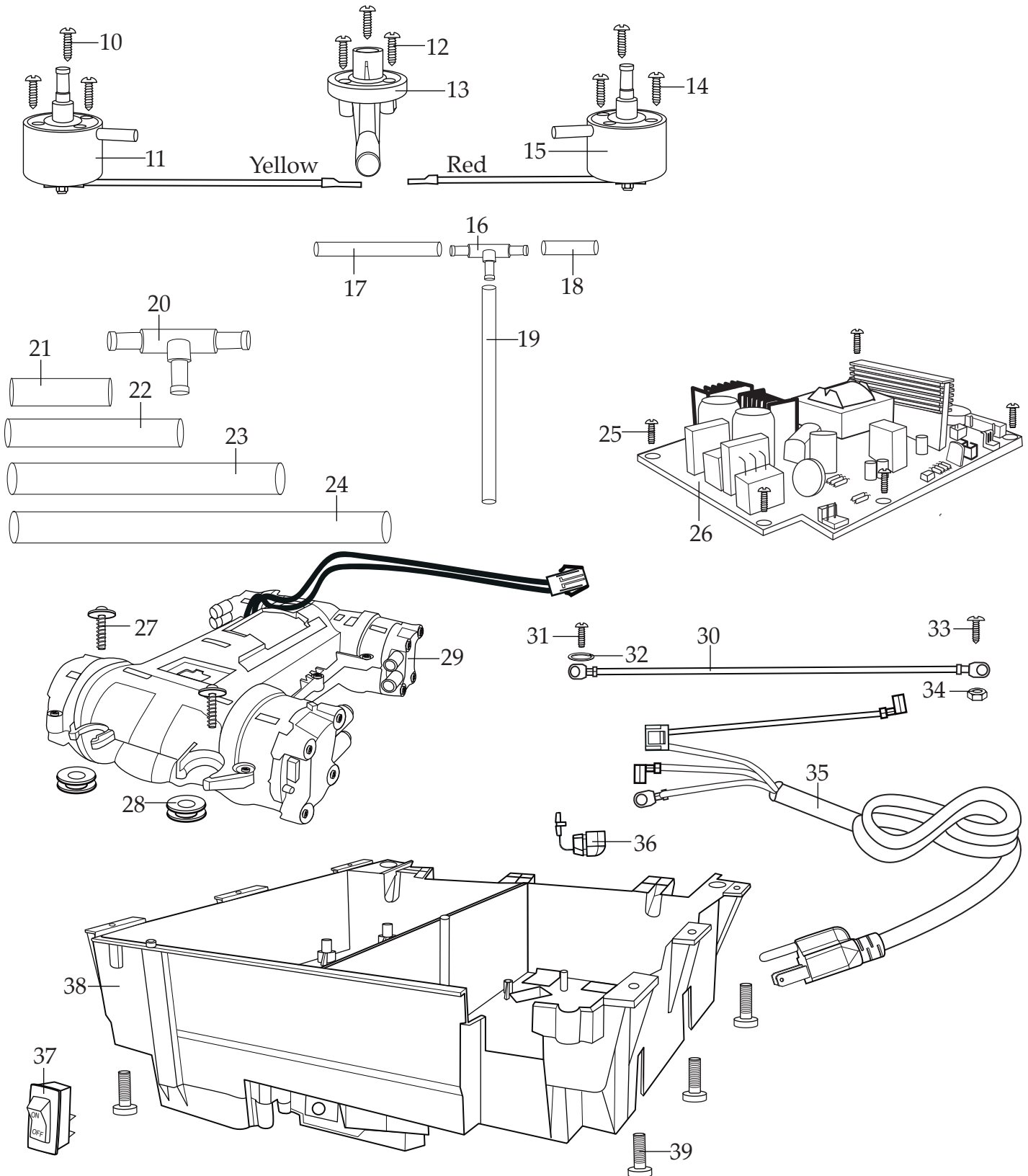

Illustration #	Part #	Description
1	035774	Lid Gasket
2	035776	Upper Hingde Cover Set (both right & left)
3	035808	Heat Sealing Bar
4	035777	Air Filter Cover
5	035778	Base Plate
6	035779	Screw (9 required)
7	035781	Screw (2 required)
8	035780	Foot (4 required)
9	035779	Screw (4 required)
10	035785	Screw (3 required)
11	035782	Heat Connector Assembly w/ Yellow Lead
12	035785	Screw (3 required)
13	035784	Air Filter Suction Base
14	035785	Screw (3 required)
15	035783	Heat Connector Assembly w/ Red Lead
16	035786	Small T Connector
17	035804	3" Clear Hose
18	035803	1.375" Clear Hose
19	035805	11" Clear Hose
20	035787	Large T Connector
21	035797	1.75" White Hose (5 required)
22	035796	5.25" White Hose
23	035798	8.25" White Hose
24	035799	10.75" White Hose
25	035790	Screw (5 required)
26	035788	Power PCB
27	035795	Screw (6 required)
28	035794	Motor Mount (6 required)
29	035789	Motor Assembly
30	035791	Ground Lead

Illustration #	Part #	Description
31	035790	Screw
32	035801	Washer
33	035800	Screw
34	035802	Nut
35	035793	Cord Assembly
36	035806	Strain Relief
37	035792	Toggle Switch
38	035775	Lower Housing Assembly
39	035779	Screw (6 required)