



PIZZA PREP TABLE

DPP90-12-S3
3-Door



TECHNICAL SPECIFICATIONS

| | |
|-----------------------|-----------------|
| Voltage/Frequency | 115V/60Hz |
| Refrigerant | R290 |
| Type of Defrost | Automatic |
| Interior Material | Stainless Steel |
| Exterior Material | Stainless Steel |
| Temperature Range °F | 33 ~ 41°F |
| Compressor Power (HP) | 1/2 |
| Nema Config. | NEMA5-15P |



PRODUCT FEATURES

- The compressor is mounted in the back and placed in the coolest possible area; this makes it easily accessible for servicing.
- Digital temperature controls with LED display for precise adjustment and automatic defrosting system.
- Temperatures in the cabinet range from 33 to 41 degrees Fahrenheit
- Higher Resistance to dust, high quality condenser.
- R290 Natural Refrigerant promotes faster cool down and efficient energy consumption.
- Self-closing doors at 60° with stay open feature.
- Stainless steel interior & exterior, sealed interior floors, and rounded cabinet corners for easy cleaning.
- 6" deep 1/3 plastic plan included.
- High quality coated stainless adjustable shelves prevent peel and rust.
- Lifetime warranty on hinges.
- 5" casters with lock for easy mobility.



HIGH QUALITY STAINLESS STEEL & ROBUST DESIGN



Los Angeles | San Francisco | Dallas
Houston | Florida | Chicago | New Jersey

1-800-931-8628

@ info@dukersusa.com

www.DukersUSA.com

DETAILS & SPECIFICATIONS

PIZZA PREP TABLE DPP90-12-S3

Front View

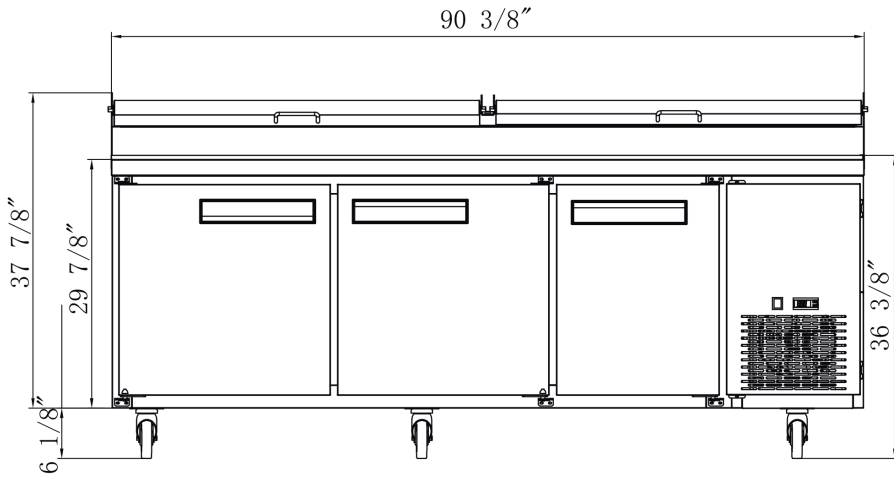

Side View

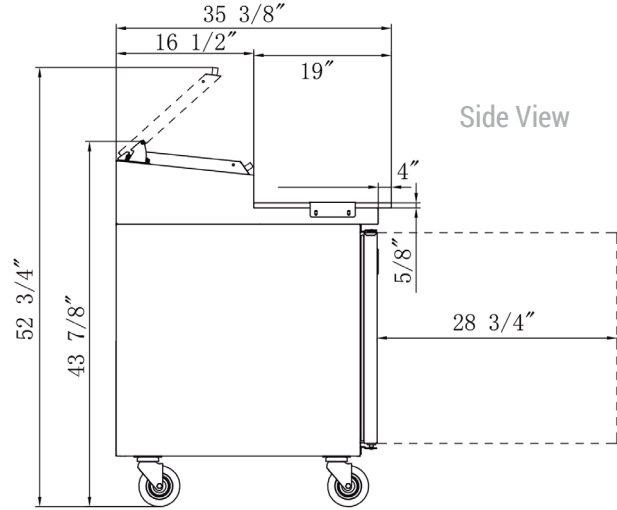

1/3 PAN COUNT: 12

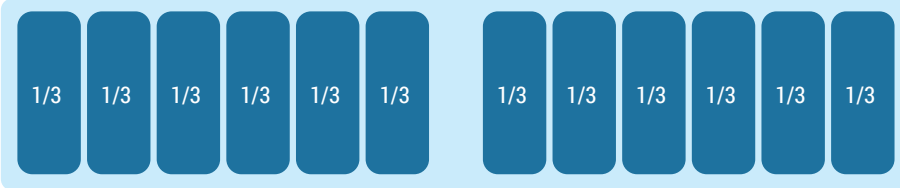

MODEL DPP90-12-S3

| | |
|---------------------------|--------------|
| Rated Voltage | 115V |
| Rated Frequency | 60Hz |
| Total Input Power | 620W |
| Total Current | 8.5A |
| Total Capacity | 24.89cu ft |
| Climatic Category | 4-5 |
| Protection Type | I |
| Design Pressure High Side | 300 PSIG |
| Design Pressure Low Side | 150 PSIG |
| Insulation Blowing Gas | C-Pentane |
| Refrigerant | R290/4.93 oz |

| MODEL | EXTERNAL DIMENSION WXDXH (INCHES) | PACKAGING DIMENSION WXDXH (INCHES) | PRODUCT NET WEIGHT | # OF SHELVES | 40HQ CONTAINER CERT. |
|-------------|--------------------------------------|---------------------------------------|-----------------------|-----------------|-------------------------|
| DPP90-12-S3 | 90 3/8 x 31 1/2 x 43 7/8 | 91 3/8 x 35 7/8 x 48 3/8 | 423 lbs | 3 | 26 |



Los Angeles | San Francisco | Dallas
Houston | Florida | Chicago | New Jersey

1-800-931-8628

info@dukersusa.com

www.DukersUSA.com