



Stock Pot DCSPA1



Catch Tray



Ventilation



Legs

Knobs

Cast Iron
Cooking Surface



PRODUCT DESCRIPTION

- Stainless steel sides and front valve cover.
- Stainless steel tubing for pilots and pilot tips per burner ring.
- Heavy duty cast iron three-ring burner, rated at a total of 80,000 BTU/h.
- Each burner is equipped with two continuous pilots.
- Heavy duty cast iron and top grates.
- Two manual controls to operate the inner and outer rings independently.
- 3/4" NPT rear gas connection and regulator standard.
- Stainless steel legs standard.
- Full length seamless drip pan for easy cleanup.



HIGH QUALITY STAINLESS STEEL & ROBUST DESIGN

STOCK POT MODEL	DIMENSION		
	Width	Depth	Height
DCSPA1	18 in	24 1/4 in	22 3/4 in



Los Angeles | San Francisco | Dallas
Houston | Florida | Chicago | New Jersey

1-800-931-8628

@ info@dukersusa.com

www.DukersUSA.com

DETAILS & SPECIFICATIONS

STOCK POT DCSPA1

Front View

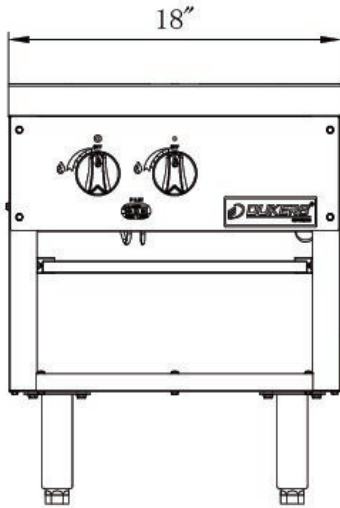

Side View

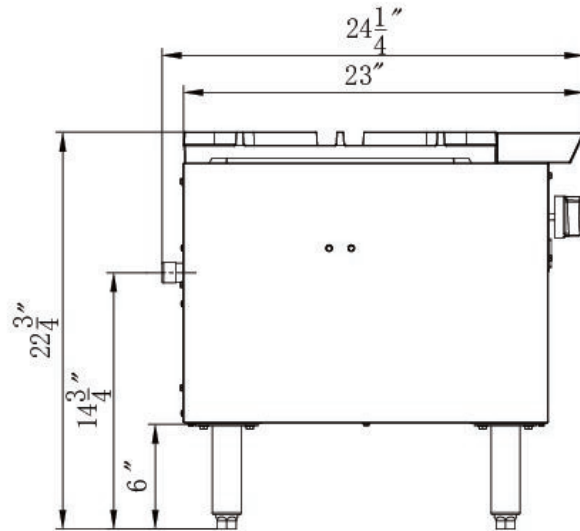

Top View

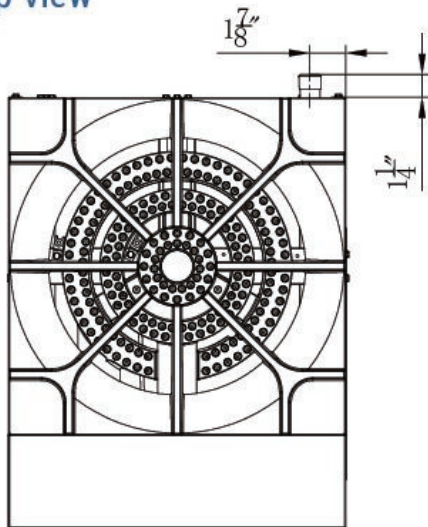

DCSPA1

GAS SOURCE	NG/Propane
COOKING AREA	18x18in
BURNER SINGLE	2 count
BURNER	40000 BTU/H
COMBINED GAS	80000 BTU/H
PRESSURE	NG: 5 "WC Propane: 10 "WC
NOZZEL	NG: 32# Propane: 48#



Model	Packaging Dimensions (inches)			Net Weight (lbs)	Ship Weight (lbs)	Container Capacity 40'HQ
	W	D	H			
DCSPA1	21 1/8"	30 7/8"	24"	115	157	240



Los Angeles | San Francisco | Dallas
Houston | Florida | Chicago | New Jersey

1-800-931-8628

info@dukersusa.com

www.DukersUSA.com