

# Body-Solid®

Built for Life

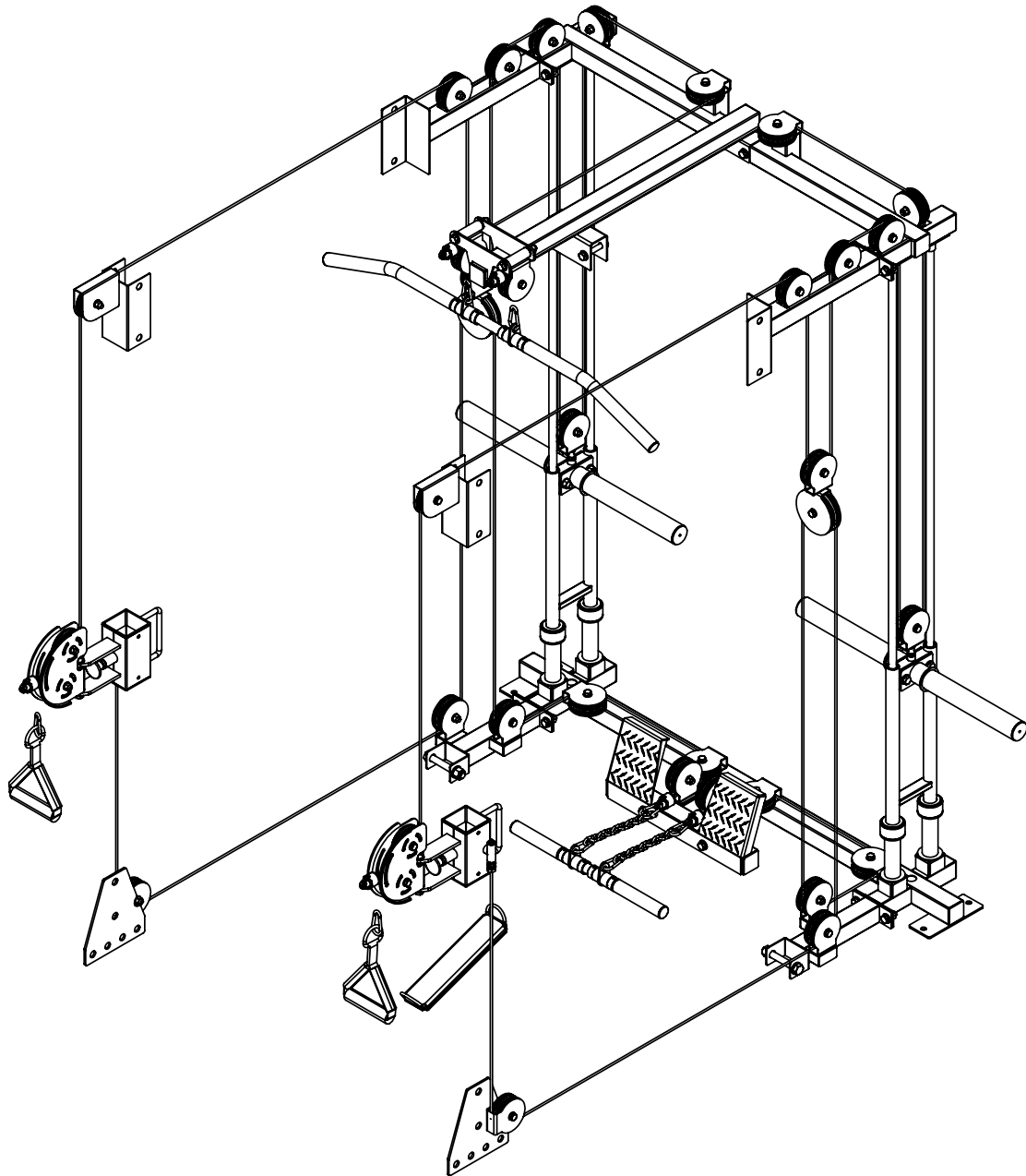

# GPRFT

Assembly & Instructions

**OWNER'S & MANUAL**

V. GPRFT-20230719

# Warning, Safety & Maintenance

Be sure that all users carefully read and understand all warning, safety and maintenance labels on the machine before each use. Failure to do so may result in death or serious injury.

It is imperative that you retain this Owner's Manual and be sure all warning labels are legible and intact. Replacement Owner's Manuals and warning labels are available from your local Body-Solid dealer.

If you have any questions about the operation, set up or maintenance of this machine please call our customer service department at 1 (800) 556-3113.

**THERE IS A RISK ASSUMED BY INDIVIDUALS WHO USE THIS TYPE OF EQUIPMENT. TO MINIMIZE RISK, YOU MUST FOLLOW THESE RULES:**

1. Inspect equipment before each workout. Check that all nuts, bolts, screws and pop pins are in place and fully tightened. Also, before use, check cables for signs of wear. Replace all worn parts immediately. Never use machine if any parts are damaged or missing. **FAILURE TO FOLLOW THESE RULES MAY RESULT IN SERIOUS INJURY.**
2. Keep clear of the cables and all moving parts when the machine is in use.
3. Always make sure all Snap Links are closed when doing any cable/pulley/strap exercises.
4. Exercise with care. Perform your exercises at a smooth moderate pace; never perform jerky or uncoordinated movements that may cause injury.
5. It is recommended that you should workout with a training partner.
6. Do not allow children or minors to play on or around this equipment.
7. If unsure of proper use of equipment, call your local Body-Solid distributor or the Body-Solid customer service department at 1-800-556-3113.
8. **WARNING:** Consult your physician before starting your exercise program. For your own safety, do not begin any exercise program without proper instruction. RAL8-6-03 WC-54

**! DANGER !**

**MAXIMUM 1 USER AT A TIME**

Usage by two or more users is not permitted at any time. Death or serious injuries will result with improper exercise. Use only the weight stack supplied by the manufacturer. DO NOT add additional resistance, unauthorized accessories or attachments to the machine. Never pin the weight stack or top plate into an elevated position.

## WARNING

### Safety and Maintenance of Cables

**IMPORTANT:** Cables are wear items. It is your responsibility to prevent unexpected breakage. **Cable inspection should be performed daily.** Inspect all cables, the nylon coating on all cables, and the area near the fitting at each end of each cable. **Replace any damaged or worn cable immediately.** Do not allow the machine to be used until damaged or worn cables are replaced. Using or allowing a machine to be used with a suspect cable can result in serious injury. See Owner's Manual for more information.

For Body-Solid Customer Service  
Call 1-800-556-3113

## MAINTENANCE SCHEDULE

Check the function and integrity of the following components. As noted, inspect equipment before each workout. Replace all damaged, broken or worn components immediately.

	D	A	I	L	Y	W	E	E	K	L	Y
Cables: Check tension, end fittings, and coating						✓					
Check that locking nut at weight stack is tight											✓
Upholstery: Wipe down and dry						✓					
Clean and condition											✓
Frame: Wipe down and dry						✓					
Polish / Wax											✓
Chrome: Wipe down and dry						✓					
Polish / Lubricate											✓
Nuts / Bolts / Fasteners: Tighten and / or adjust as needed											✓
Guide Rods: Lubricate and clean											✓
Linear Rods: Lubricate and clean											✓
Seat Sleeves: Lubricate and clean											✓
Adjustments / Locking Pins / Tightening Knobs											✓
Weight Stack Pins											✓
Warning Instruction Labels											✓
Springs / Pop Pins						✓					
Anti Skid Surfaces											✓
Hand Grips / Rollers											✓

For Body-Solid Customer Service  
Call 1-800-556-3113  
#MSSTR0803

## Table of Contents

- SAFETY INSTRUCTIONS..... PAGE 4
- PREPARATION..... PAGE 5
- PART / HARDWARE LIST..... PAGE 6
- HARDWARE ILLUSTRATION..... PAGE 8
- ASSEMBLY INSTRUCTIONS..... PAGE 12
- EXPLODED VIEW..... PAGE 34
- CONTACT PAGE..... PAGE 36

# Important Safety Instructions

Before beginning any fitness program, you should obtain a complete physical examination from your physician.

*Il est conseillé de subir un examen médical complet avant d'entreprendre tout programme d'exercice.  
Si vous avez des étourdissements ou des faiblesses, arrêtez les exercices immédiatement.*

*Antes de comenzar cualquier programa de ejercicios, deberías tener un examen físico con su doctor.*

## **When using exercise equipment, you should always take basic precautions, including the following:**

- Read all instructions before using the **GPRFT**. These instructions are written to ensure your safety and to protect the unit.
- **Do not remove any safety labels from the machine.**
- Do not allow children on or near the equipment.
- Use the equipment only for its intended purpose as described in this guide. Do not use accessory attachments that are not recommended by the manufacturer. Such attachments might cause injuries.
- Wear proper exercise clothing and shoes for your workout, no loose clothing.
- Keep hands, limbs, loose clothing, and long hair well out of the way of all moving parts.
- Use care when getting on or off the unit.
- Do not overexert yourself or work to exhaustion.
- If you feel any pain or abnormal symptoms, stop your workout immediately and consult your physician.
- Never operate unit when it has been dropped or damaged. Return the equipment to a service center for examination and repair.
- Never drop or insert objects into any opening in the equipment.
- Always check the unit and its cables before each use. Make sure that all fasteners and cables are secure and in good working condition.
- Do not use the equipment outdoors or near water.

## **Personal Safety During Assembly**

- Before beginning assembly, please take the time to read the instructions thoroughly.
- Read each step in the assembly instructions and follow the steps in sequence. Do not skip ahead. If you skip ahead, you may learn later that you have to disassemble components and that you may have damaged the equipment.
- Assemble and operate the **GPRFT** on a solid, level surface. Locate the unit a few feet from the walls or furniture to provide easy access.

The **GPRFT** is designed for your enjoyment. By following these precautions and using common sense, you will have many safe and pleasurable hours of healthful exercise with your Body-Solid **Functional Trainer Kit for GPR400**.

After assembly, you should check all functions to ensure correct operation. If you experience problems, first recheck the assembly instructions to locate any possible errors made during assembly. If you are unable to correct the problem, call the dealer from whom you purchased the machine or call **1-800-556-3113** for the dealer nearest you.

## **Obtaining Service**

Please use this Owner's Manual to make sure that all parts have been included in your shipment. When ordering parts, you must use the part number and description from this Owner's Manual. Use only Body-Solid replacement parts when servicing this machine. Failure to do so will void your warranty and could result in personal injury.

For information about product operation or service, check out the official Body-Solid website at [www.bodysolid.com](http://www.bodysolid.com) or contact an authorized Body-Solid dealer or a Body-Solid factory-authorized service company or contact Body-Solid customer service at one of the following:

**Toll Free: 1-800-556-3113**  
**Phone: 1-708-427-3555**  
**Fax: 1-708-427-3556**  
**Hours: M-F 8:30-5:00 CST**  
**E-Mail: [service@bodysolid.com](mailto:service@bodysolid.com)**

**Or write to: Body-Solid, Inc.**  
**Service Department**  
**1900 S. Des Plaines Ave.**  
**Forest Park, IL 60130 USA**

**Retain this Owner's Manual for future reference. If you need to order replacement parts please be prepared to provide the following information when contacting us so that we can assist you better.**

- 1. Model Number**
- 2. Place of Purchase**
- 3. Serial Number (S/N)**
- 4. Part # and Description**

# Preparation

Thank you for purchasing the **GPRFT**. This Product is part of the Body-Solid line of quality strength training machines, which lets you target specific muscle groups to achieve better muscle tone and overall body conditioning. To maximize your use of the equipment please study this Owner's Manual thoroughly.

## **Required Tools**

The basic tools that you must obtain before assembling the **GPRFT** include but are not limited to:

- Standard Wrench Set
- Metric Wrench Set
- Adjustable Wrench

## **Installation Requirements**

Follow these installation requirements when assembling the **GPRFT**:

Set up the **GPRFT** on a solid, flat surface. A smooth, flat surface under the machine helps keep it level. A level machine has fewer malfunctions.

Provide ample space around the machine. Open space around the machine allows for easier access.

Insert all bolts in the same direction. For aesthetic purposes, insert all bolts in the same direction unless specified (in text or illustrations) to do otherwise.

Leave room for adjustments. Tighten fasteners such as bolts, nuts, and screws so the unit is stable, but leave room for adjustments. Do not fully tighten fasteners until instructed in the assembly steps to do so.

**Fill out and mail the warranty card.**

## **Assembly Tips**

Read all "Notes" on each page before beginning each step.

While you may be able to assemble the **GPRFT** using the illustrations only, important safety notes and other tips are included in the text.

Some pieces may have extra holes that you will not use. Use only those holes indicated in the instructions and illustrations.

**NOTE:** With so many assembled parts, proper alignment and adjustment is critical. While tightening the nuts and bolts, be sure to leave room for adjustments.

**CAUTION:** Obtain assistance! If you feel like you can't assemble the **GPRFT** by yourself then do not attempt to do so as this could result in injury. Review the installation requirements before proceeding with the following steps.

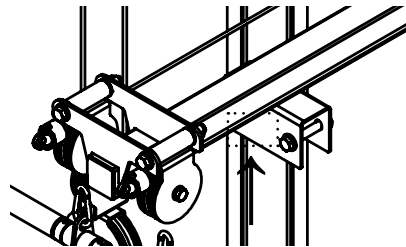

Your S/N# can  
be found here

Body-Solid continually seeks ways to improve the performance, specifications and product manuals in order to ensure that only superior products are released from our factories. Please take the time to carefully read through this manual thoroughly. Instructions contained in this document are not intended to cover all details or variations possible with Body-Solid equipment, or to cover every contingency that may be met in conjunction with installation, operation, maintenance or troubleshooting of the equipment. Even though we have prepared this manual with extreme care, neither the publisher nor the author can accept responsibility for any errors in, or omission from, the information given. Should additional information be required, or should situations arise that are not covered by this manual, the matter should be directed to your local Body-Solid representative, or the Service Department at Body-Solid Inc. in Forest Park, Illinois.

## GPRFT Parts & Hardware List

<b>Part#</b>	<b>Qty</b>	<b>Description</b>
A	1	CENTER BASE FRAME
B	1	RIGHT BASE FRAME
C	1	LEFT BASE FRAME
D	1	FOOTPLATE
E	4	RISER
F	2	CARRIAGE
G	4	WEIGHT HORN
H	4	CHROME GUIDE ROD
J	2	GUIDE ROD BRACKET
K	1	RIGHT TOP FRAME
L	1	REAR TOP FRAME
M	1	LEFT TOP FRAME
N	1	CENTER TOP FRAME
P	2	LAT PULLEY BRACKET
Q	2	FLOATING PULLEY BRACKET
R	2	PULLEY BRACKET
S	2	FRONT TOP PULLEY BRACKET
T	2	SLIDING HANDLE
U	2	DOUBLE PULLEY BRACKET
V	1	FRONT RIGHT PULLEY BRACKET
W	1	FRONT LEFT PULLEY BRACKET
X	1	LAT BAR
Y	1	SHORT BAR
1	2	M16x110mm HEX HEAD BOLT
2	4	M12x110mm HEX HEAD BOLT
3	6	M12x75mm HEX HEAD BOLT
4	4	M12x60mm HEX HEAD BOLT
5	8	M12x30mm HEX HEAD BOLT
6	36	M10x50mm HEX HEAD BOLT
7	4	M10x20mm HEX HEAD BOLT
8	12	M6x12mm BUTTON HEAD CAP SCREW
9	12	M16 WASHER
10	44	M12 WASHER
11	76	M10 WASHER

## GPRFT Parts & Hardware List

<b>Part#</b>	<b>Qty</b>	<b>Description</b>
12	4	M10 LOCK WASHER
13	6	M16 NYLON LOCK NUT
14	22	M12 NYLON LOCK NUT
15	36	M10 NYLON LOCK NUT
17	2	POP PIN
18	8	METAL BUSHING, $\varnothing 25 \times \varnothing 19.6 \times \varnothing 12.5 \times 10 \text{mm}$
19	4	PLASTIC SQUARE BUSHING, 84x84mm
20	4	RUBBER DONUT
21	8	PLASTIC BUSHING, $\varnothing 27.2 \times \varnothing 50.5 \times 65 \text{mm}$
22	32	PULLEY, $\varnothing 90 \text{mm}$
23	2	PULLEY, $\varnothing 117 \text{mm}$
24	2	TOP CABLE, 7880mm
25	2	LOW CABLE, 5500mm
26	6	CABLE CONNECTOR
27	6	ACCESSORY CONNECTOR
28	2	CABLE CONNECTOR BOLT
29	2	M12 LOCK WASHER
30	6	M12 HEX NUT
31	2	SHORT BAR HAND GRIP
32	4	PLASTIC ROUND PLUG, $\varnothing 31 \text{mm}$
33	2	STEEL CHAIN
34	8	SNAP LINK
35	2	STRAP HANDLE
36	2	LAT BAR HAND GRIP
37	1	ANKLE STRAP
38	4	M16x115mm HEX HEAD BOLT

# GPRFT Hardware Illustration

Part #1      HEX HEAD BOLT M16x110mm

QTY. 2

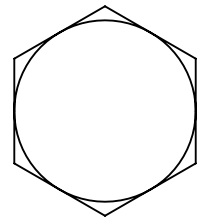
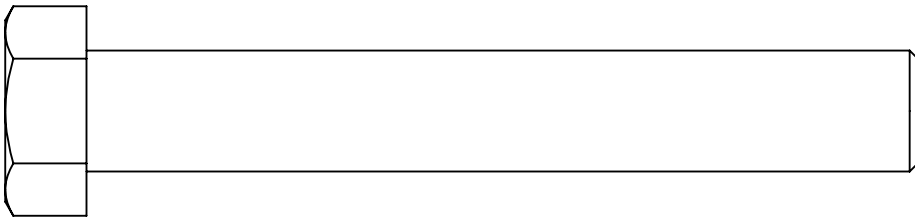

Part #2      HEX HEAD BOLT M12x110mm

QTY. 4

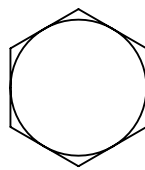
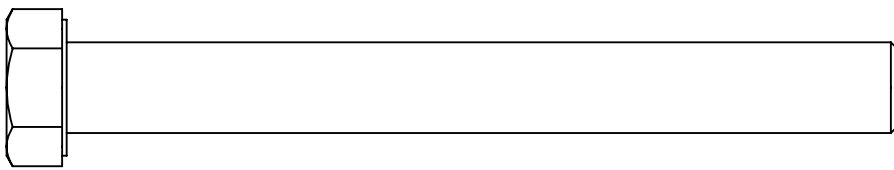

Part #3      HEX HEAD BOLT M12x75mm

QTY. 6

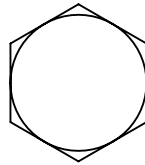
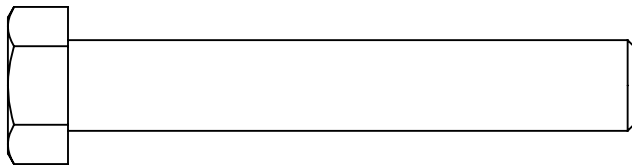

Part #4      HEX HEAD BOLT M12x60mm

QTY. 4

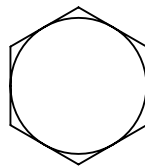
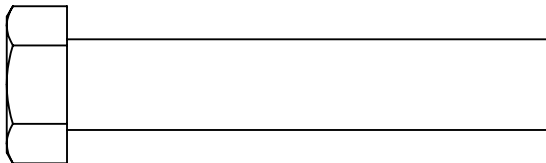

Part #5      HEX HEAD BOLT M12x30mm

QTY. 8

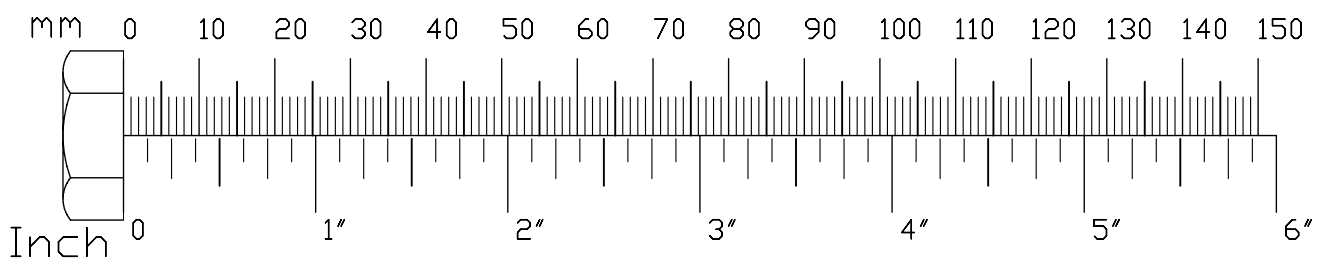
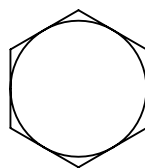
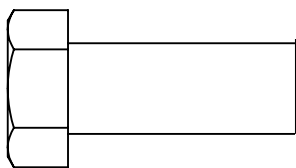



# GPRFT Hardware Illustration

Part #6 HEX HEAD BOLT M10x50mm

QTY. 36

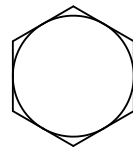
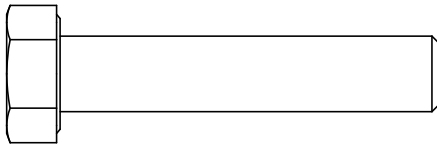

Part #7 HEX HEAD BOLT M10x20mm

QTY. 4

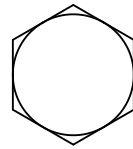
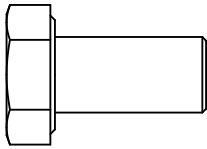

Part #8 BUTTON HEAD CAP SCREW M6x12mm

QTY. 12

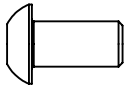

Part #9 M16 WASHER

QTY. 12

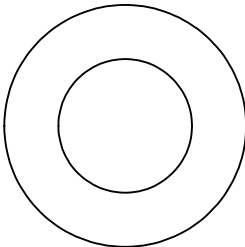

Part #10 M12 WASHER

QTY. 44

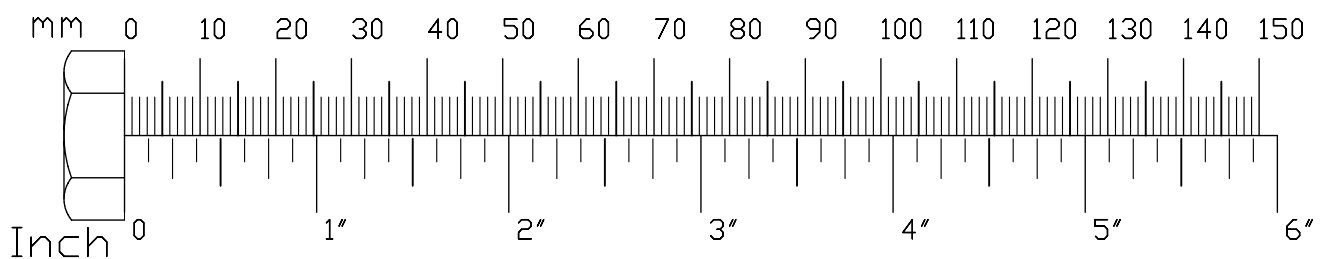
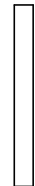
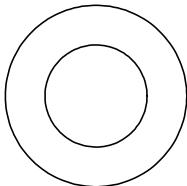

# GPRFT Hardware Illustration

Part #11

M10 WASHER

QTY. 76

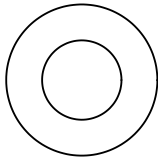

Part #12

M10 LOCK WASHER

QTY. 4

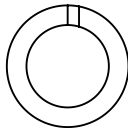

Part #13

M16 NYLON LOCK NUT

QTY. 6

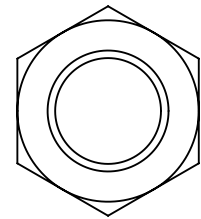
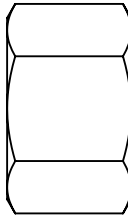

Part #14

M12 NYLON LOCK NUT

QTY. 22

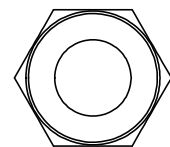
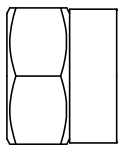

Part #15

M10 NYLON LOCK NUT

QTY. 36

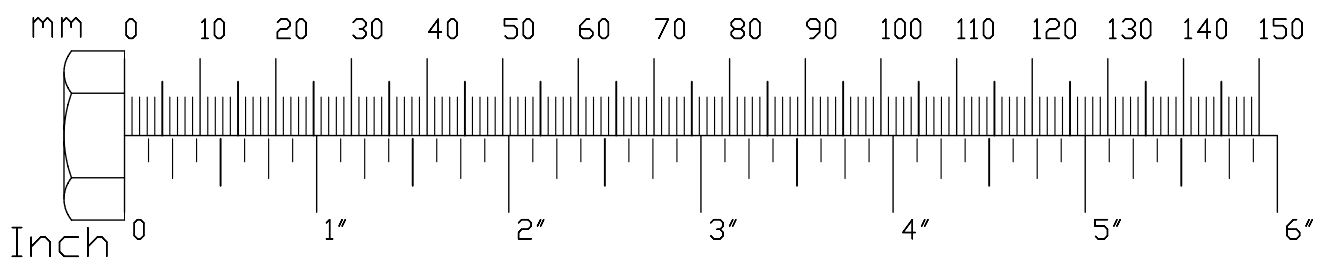
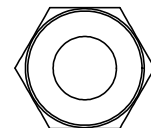
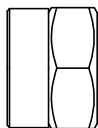

# GPRFT Hardware Illustration

Part #29

M12 LOCK WASHER

QTY. 2

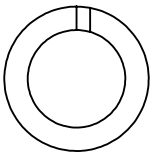

Part #30

M12 HEX NUT

QTY. 6

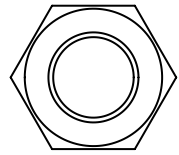

Part #38

HEX HEAD BOLT M16x115mm

QTY. 4

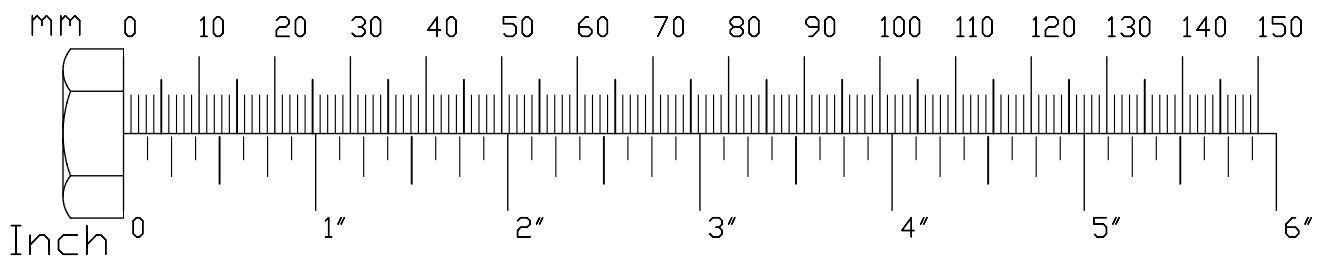
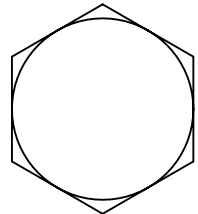
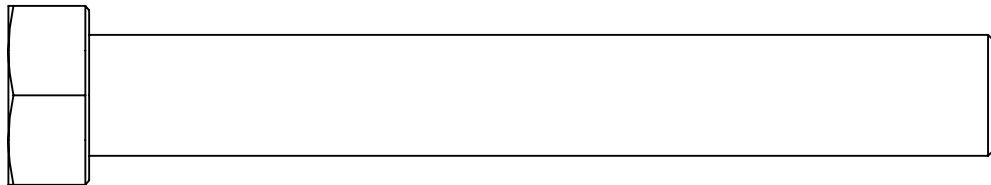

**STEP****1**

**Be careful to assemble all components in the sequence they are presented.**

**NOTE:**

**Finger tighten all hardware in this step. DO NOT wrench tighten until instructed. Some components may be pre-assembled. Nylon lock nuts will not fully screw onto bolts, they must be wrench tightened to fully go on.**

- 1A.** Disassemble the Left side of the Upright (**AB**) from GPR400 by removing:
- 6 - (#1) M16x110mm Hex Head Bolt (Hardware is from GPR400)**
  - 12 - (#9) M16 Washer (Hardware is from GPR400)**
  - 6 - (#13) M16 Nylon Lock Nut (Hardware is from GPR400)**
- 1B.** Insert Sliding Handle (**T**) onto the Upright (**AB**).
- 1C.** Attach the Upright (**AB**) to Base Frame (**AA**) using:
- 4 - (#1) M16x110mm Hex Head Bolt (Hardware is from GPR400)**
  - 8 - (#9) M16 Washer (Hardware is from GPR400)**
  - 4 - (#13) M16 Nylon Lock Nut (Hardware is from GPR400)**
  - 1 - (AF) Steel Plate**
  - 1 - (W) Front Left Pulley Bracket**
- 1D.** Attach Top Side Frame (**AC**), Upright (**AB**) & Front Top Pulley Bracket (**S**) together using:
- 2 - (#1) M16x110mm Hex Head Bolt (Hardware is from GPR400)**
  - 4 - (#9) M16 Washer (Hardware is from GPR400)**
  - 2 - (#13) M16 Nylon Lock Nut (Hardware is from GPR400)**
- 1E.** Screw Pop Pin (**#17**) into the Sliding Handle (**T**).
- 1F.** Attach the Double Pulley Bracket (**U**) to Sliding Handle (**T**) using:
- 1 - (#2) M12x110mm Hex Head Bolt**
  - 2 - (#10) M12 Washer**
  - 1 - (#14) M12 Nylon Lock Nut**
  - 2 - (#18) Metal Bushing**

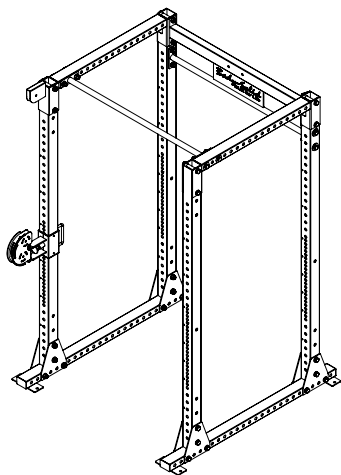

Above shows Step 1 assembled and completed.

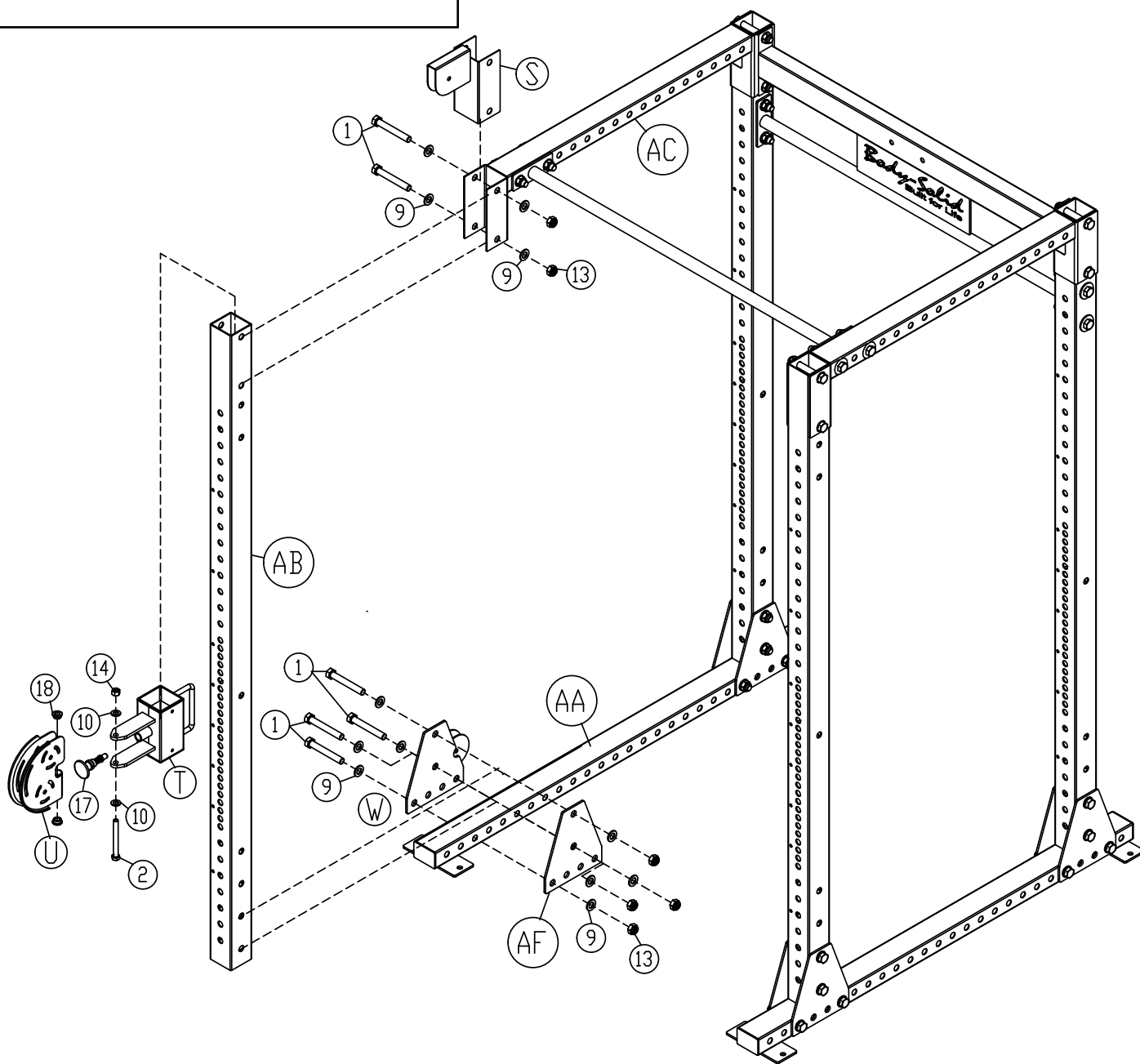

**STEP****2**

**Be careful to assemble all components in the sequence they are presented.**

**NOTE:**

**Finger tighten all hardware in this step. DO NOT wrench tighten until instructed. Some components may be pre-assembled. Nylon lock nuts will not fully screw onto bolts, they must be wrench tightened to fully go on.**

- 2A.** Disassemble the right side of the Upright (**AB**) from GPR400 by removing:
- 6 - (#1) M16x110mm Hex Head Bolt (Hardware is from GPR400)**
  - 12 - (#9) M16 Washer (Hardware is from GPR400)**
  - 6 - (#13) M16 Nylon Lock Nut (Hardware is from GPR400)**
- 2B.** Insert Sliding Handle (**T**) onto the Upright (**AB**).
- 2C.** Attach the Upright (**AB**) to Base Frame (**AA**) using:
- 4 - (#1) M16x110mm Hex Head Bolt (Hardware is from GPR400)**
  - 8 - (#9) M16 Washer (Hardware is from GPR400)**
  - 4 - (#13) M16 Nylon Lock Nut (Hardware is from GPR400)**
  - 1 - (AF) Steel Plate**
  - 1 - (V) Front Right Pulley Bracket**
- 2D.** Attach Top Side Frame (**AC**), Upright (**AB**) & Front Top Pulley Bracket (**S**) together using:
- 2 - (#1) M16x110mm Hex Head Bolt (Hardware is from GPR400)**
  - 4 - (#9) M16 Washer (Hardware is from GPR400)**
  - 2 - (#13) M16 Nylon Lock Nut (Hardware is from GPR400)**
- 2E.** Screw Pop Pin (**#17**) into the Sliding Handle (**T**).
- 2F.** Attach the Double Pulley Bracket (**U**) to Sliding Handle (**T**) using:
- 1 - (#2) M12x110mm Hex Head Bolt**
  - 2 - (#10) M12 Washer**
  - 1 - (#14) M12 Nylon Lock Nut**
  - 2 - (#18) Metal Bushing**

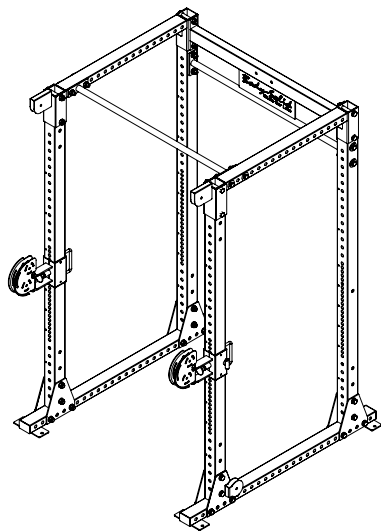

Above shows Step 2 assembled and completed.

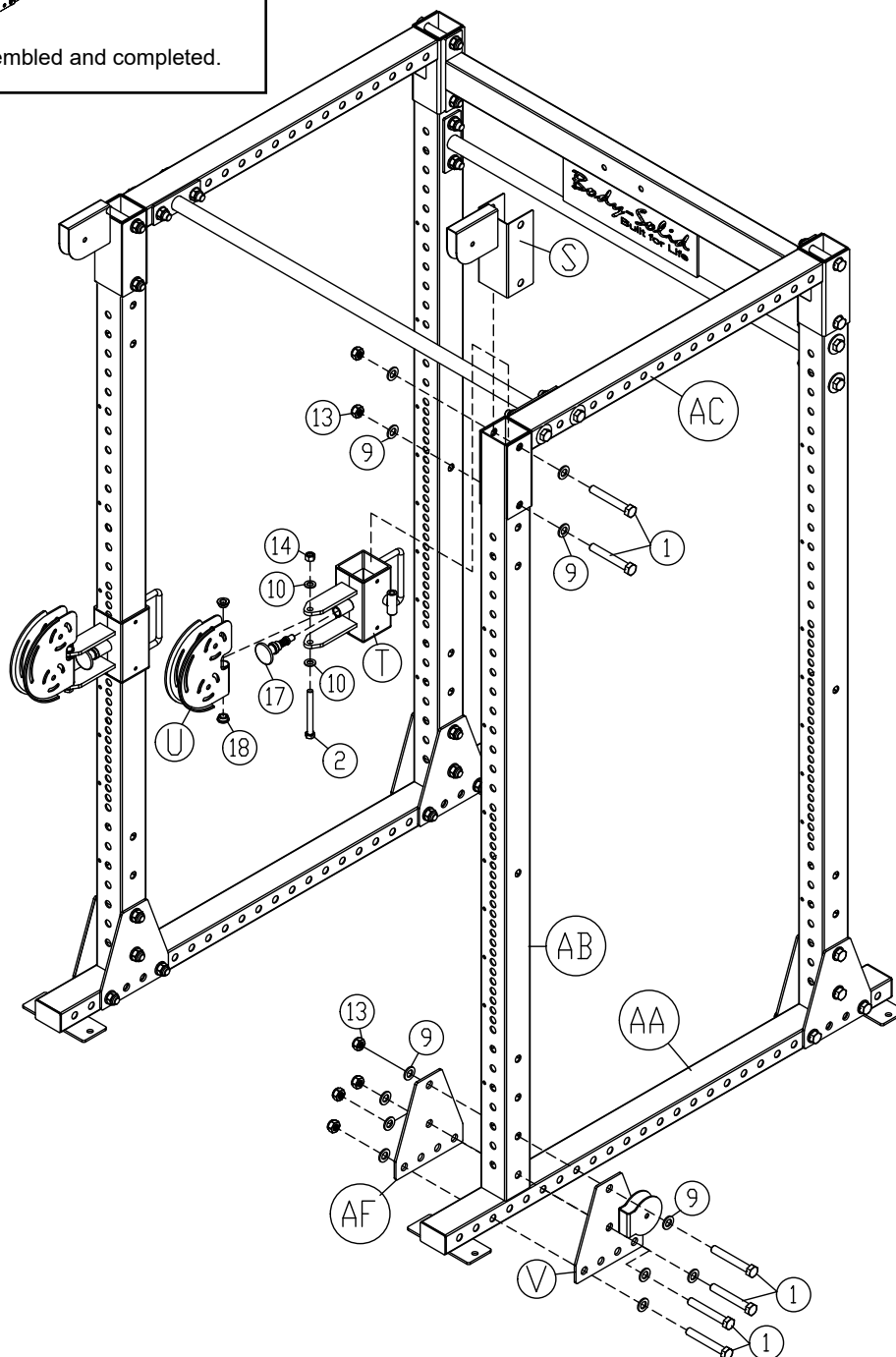

**STEP****3**

**Be careful to assemble all components in the sequence they are presented.**

**NOTE:**

**Finger tighten all hardware in this step. DO NOT wrench tighten until instructed. Some components may be pre-assembled. Nylon lock nuts will not fully screw onto bolts, they must be wrench tightened to fully go on.**

- 3A.** Attach Left and Right Base Frames (**B & C**) to Base Frames (**AA**) of GPR400 using:  
2 - (#1) M16x110mm Hex Head Bolt  
4 - (#9) M16 Washer  
2 - (#13) M16 Nylon Lock Nut
- 3B.** Attach Center Base Frame (**A**) to Left and Right Base Frame (**B & C**) using:  
4 - (#5) M12x30mm Hex Head Bolt  
8 - (#10) M12 Washer  
4 - (#14) M12 Nylon Lock Nut
- 3C.** Attach Right Top Frame (**K**) to the Right Side Frame (**AC**) using:  
2 - (#38) M16x115mm Hex Head Bolt  
4 - (#9) M16 Washer  
2 - (#13) M16 Nylon Lock Nut
- 3D.** Attach Left Top Frame (**M**) to the Left Side Frame (**AC**) using:  
2 - (#38) M16x115mm Hex Head Bolt  
4 - (#9) M16 Washer  
2 - (#13) M16 Nylon Lock Nut
- 3E.** Attach Rear Top Frame (**L**) to Left and Right Top Frames (**M & K**) using:  
4 - (#5) M12x30mm Hex Head Bolt  
8 - (#10) M12 Washer  
4 - (#14) M12 Nylon Lock Nut



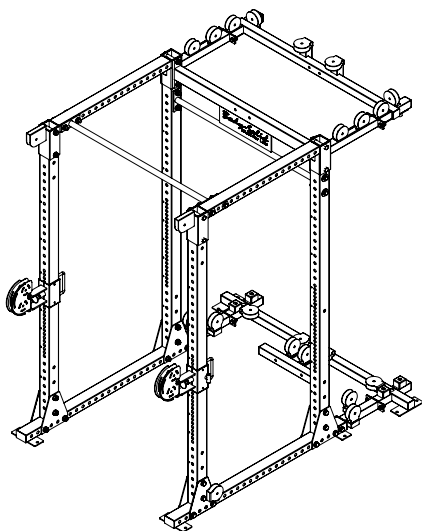

Above shows Step 3 assembled and completed.

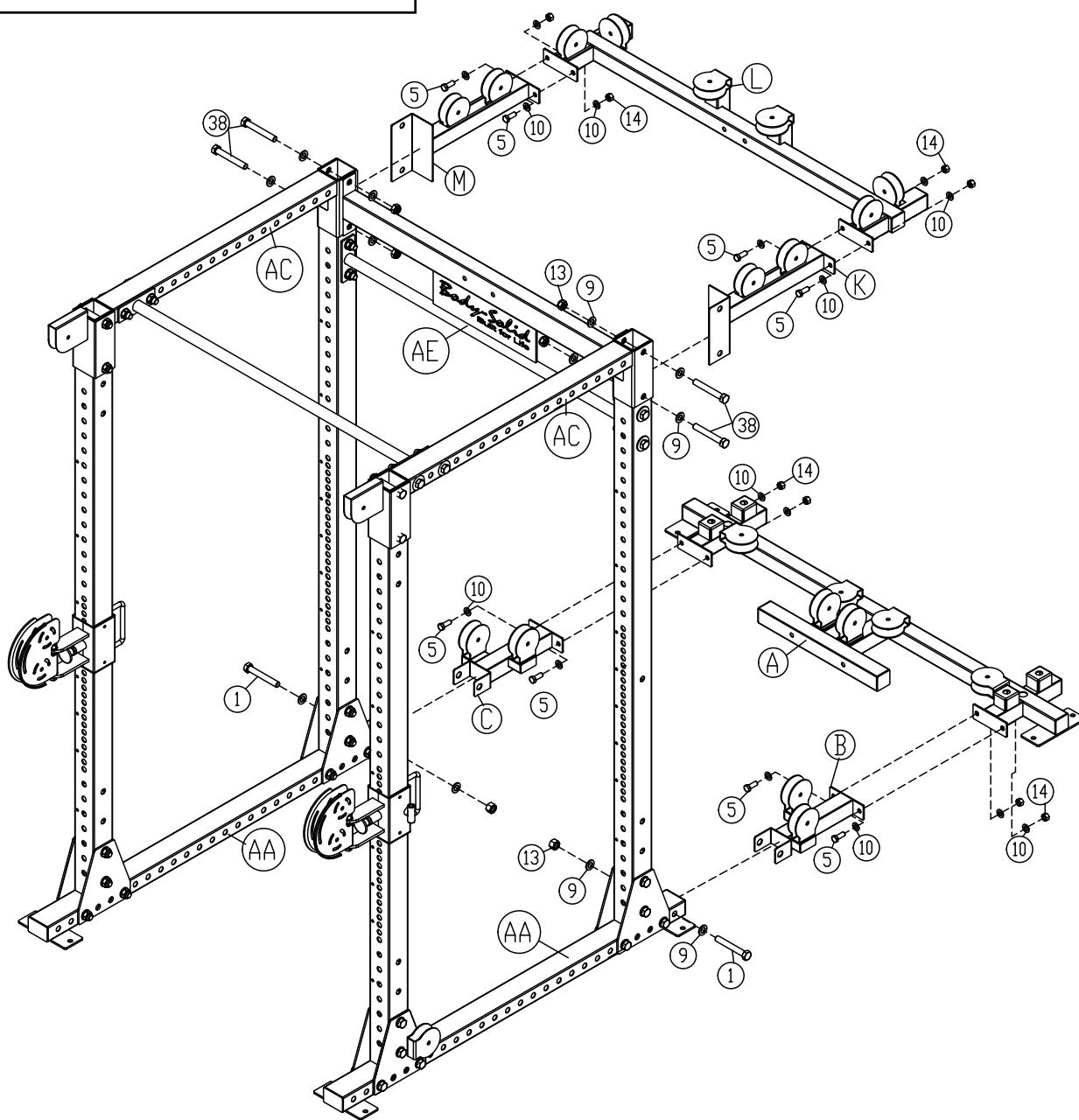

## STEP

# 4A

**Be careful to assemble all components in the sequence they are presented.**

**NOTE:**

**Finger tighten all hardware in this step. DO NOT wrench tighten until instructed. Some components may be pre-assembled. Nylon lock nuts will not fully screw onto bolts, they must be wrench tightened to fully go on.**

### PLATE LOADED VERSION

- 4A.** Install Chrome Guide Rods (**H**) into the holes of the right side of the Base Frame (**A**).
- 4B.** Install Risers (**E**) & Rubber Donuts (**#20**) and slide to the bottom of the Guide Rods
- 4D.** Install Carriage (**F**) onto the Guide Rods (**H**) .
- 4E.** Install Guide Rod Bracket (**J**) onto Guide Rods(**H**).
- 4F.** Attach Guide Rod Bracket (**J**) to Rear Top Frame (**L**) using:
  - 2 - (#7) M10x20mm Hex Head Bolt**
  - 2 - (#11) M10 Washer**
  - 2 - (#12) M10 Lock Washer**
- 4G.** Attach Weight Horns (**G**) to Carriage (**F**) using:
  - 2 - (#4) M12x60mm Hex Head Bolt**
  - 4 - (#10) M12 Washer**
  - 2 - (#14) M12 Nylon Lock Nut**
- 4H.** Install M12 Hex Nut (**#30**), M12 Lock Washer (**#29**) and Pulley Bracket (**R**) onto the Carriage (**F**).
- 4J.** Repeat the Same Steps (**4A to 4H**) on the left side of the machine.

# STEP 4A

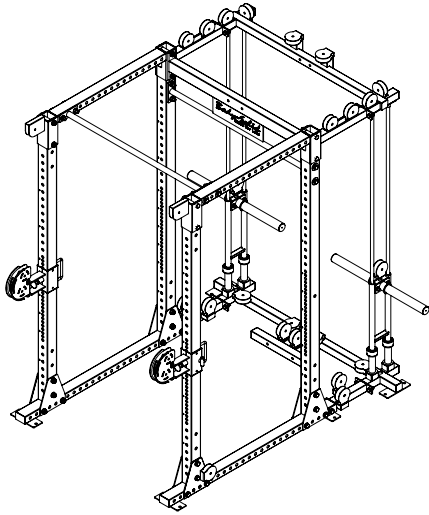

Above shows Step 4A assembled and completed.

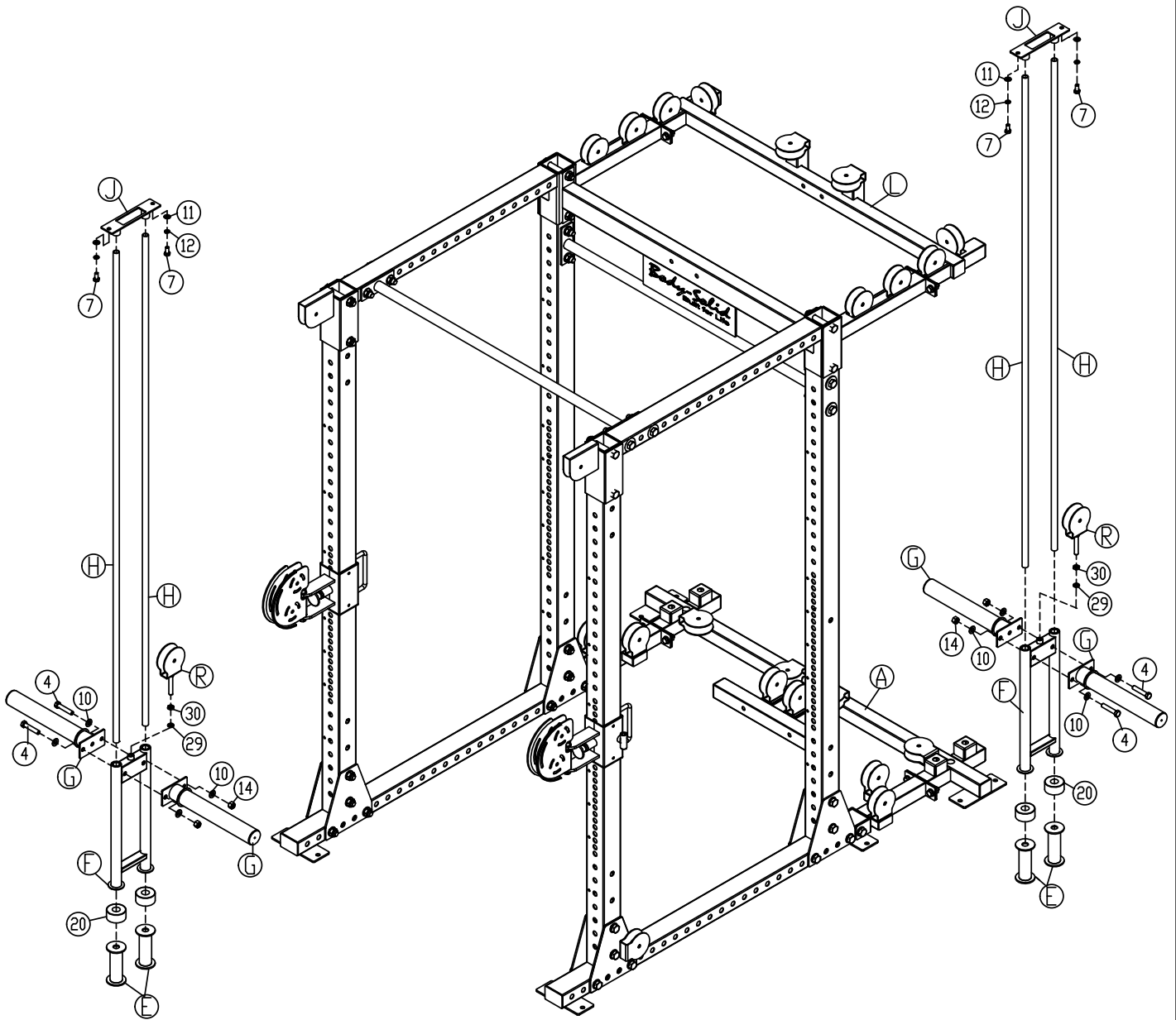

**STEP****4B**

**Be careful to assemble all components in the sequence they are presented.**

**NOTE:**

**Finger tighten all hardware in this step. DO NOT wrench tighten until instructed. Some components may be pre-assembled. Nylon lock nuts will not fully screw onto bolts, they must be wrench tightened to fully go on.**

**SELECTORIZED WEIGHT STACK VERSION**

- 4A.** Install Chrome Guide Rods (**H**) into the holes of the right side of the Base Frame (**A**).
- 4B.** Install Rubber Donuts (**#20**) and slide to the bottom of the Guide Rods (**H**).
- 4C.** Tilt Guide Rods (**H**) away from the Base Frame (**A**) and install 20pcs of weight plates (**43**). Be careful to hold guide rods steadily when installing weight plates.
- 4D.** Attach Selector Rod (**#42**) to Top Plate (**#38**) using:
  - 1 - (#39) M10x50mm Socket Head Cap Screw**
  - 1 - (#12) M10 Lock Washer**
- 4E.** Install Top Plate & Selector Rod Assembly (**#38 & #42**) onto the Guide Rods (**H**).
- 4F.** Install Guide Rod Bracket (**J**) onto Guide Rods (**H**).
- 4G.** Attach Guide Rod Bracket (**J**) to Rear Top Frame (**L**) using:
  - 2 - (#7) M10x20mm Hex Head Bolt**
  - 2 - (#11) M10 Washer**
  - 2 - (#12) M10 Lock Washer**
- 4H.** Install Weight Stack Pin (**#43**) using the key ring end through the Pulley Bracket (**R**).
- 4J.** Install M12 Hex Nut (**#30**), M12 Lock Washer (**#29**) and Pulley Bracket (**R**) onto the Top Plate (**#38**).
- 4K.** Repeat the Same Steps (**4A to 4J**) on the left side of the machine.

# STEP 4B

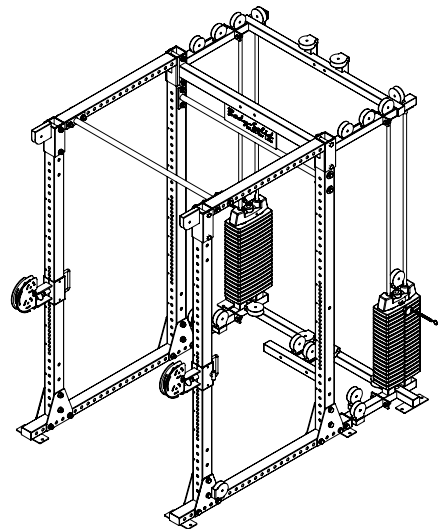

Above shows Step 4B assembled and completed.

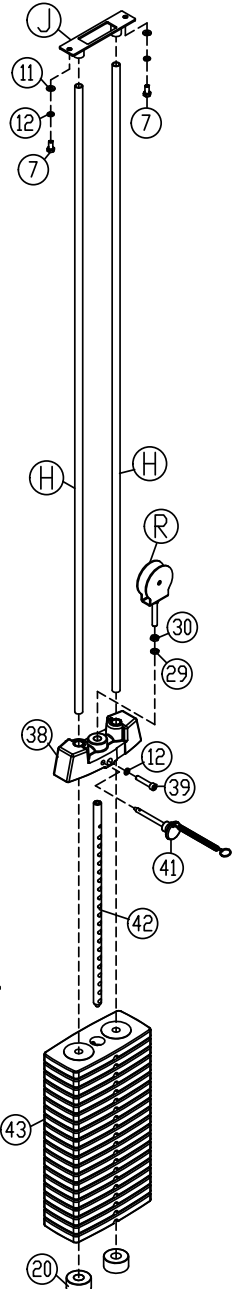
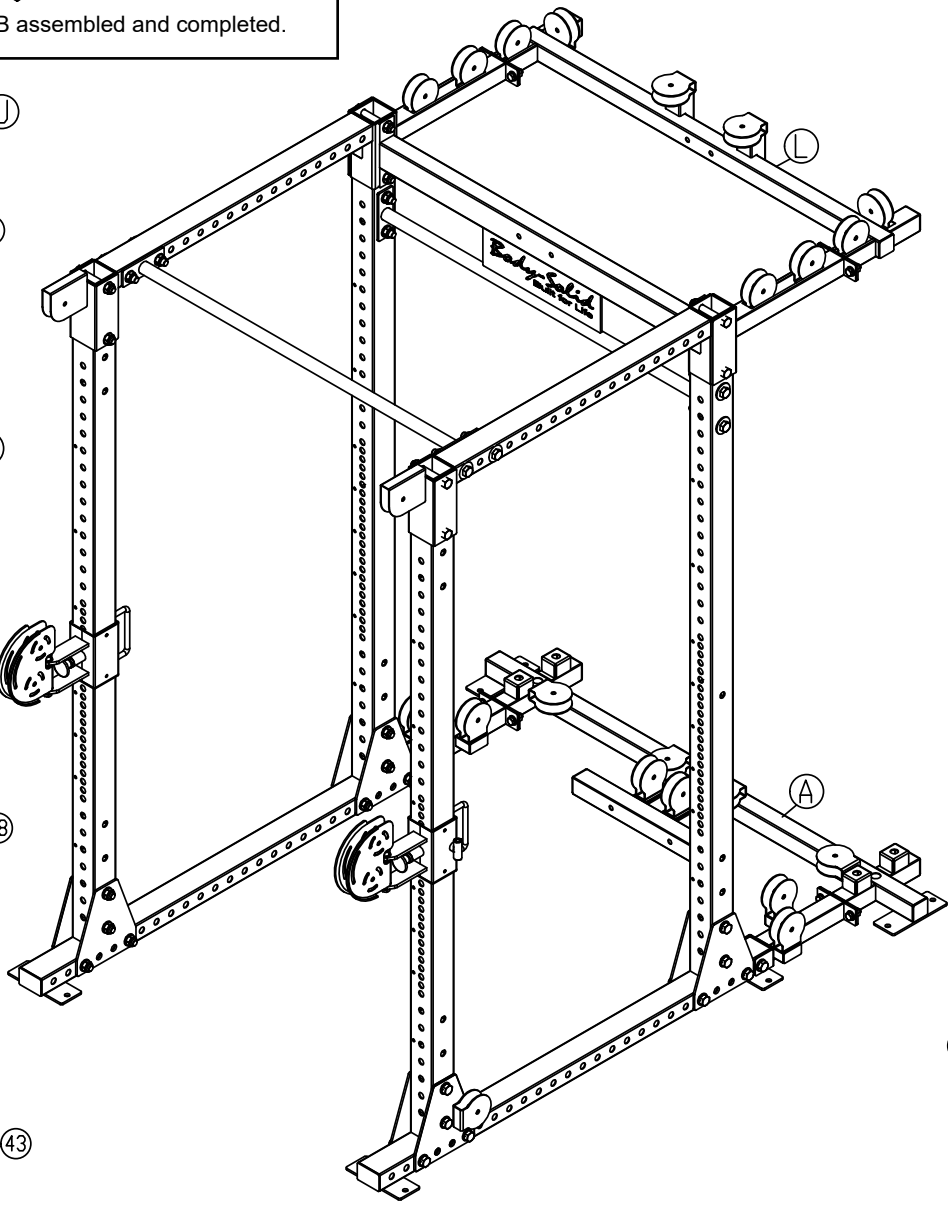
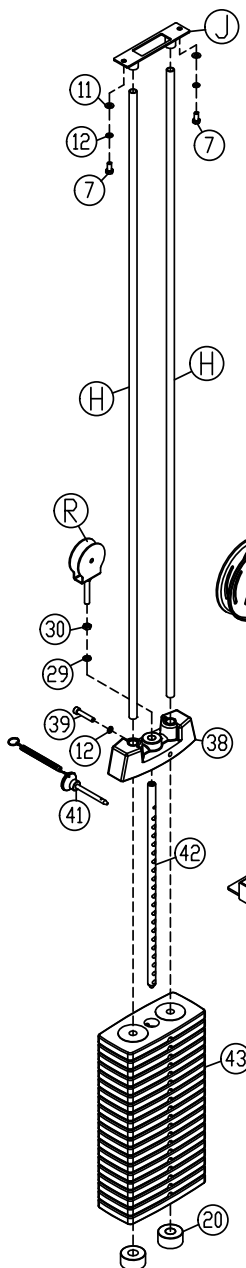

**STEP****5**

**Be careful to assemble all components in the sequence they are presented.**

**NOTE:**

**Wrench tighten ALL hardware at the end of STEP 5D. Some components may be pre-assembled. Nylon lock nuts will not fully screw onto bolts, they must be wrench tighten to fully go on.**

- 5A.** Attach Center Top Frame (**N**) to Top Frame (**AE**) of GPR400 using:  
2 - (**#3**) M12x75mm Hex Head Bolt  
4 - (**#10**) M12 Washer  
2 - (**#14**) M12 Nylon Lock Nut
- 5B.** Attach Center Top Frame (**N**) to Rear Top Frame (**L**) using:  
2 - (**#3**) M12x75mm Hex Head Bolt  
4 - (**#10**) M12 Washer  
2 - (**#14**) M12 Nylon Lock Nut
- 5C.** Attach Lat Pulley Brackets (**P**) to Center Top Frame (**N**) using:  
2 - (**#2**) M12x110mm Hex Head Bolt  
4 - (**#10**) M12 Washer  
2 - (**#14**) M12 Nylon Lock Nut  
4 - (**#18**) Metal Bushing
- 5D.** Attach Foot Plate (**D**) to Center Bottom Base Frame (**A**) using:  
2 - (**#3**) M12x75mm Hex Head Bolt  
4 - (**#10**) M12 Washer  
2 - (**#14**) M12 Nylon Lock Nut

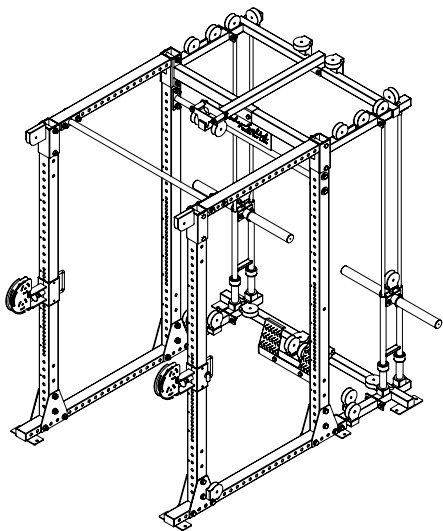

Above shows Step 5 assembled and completed.

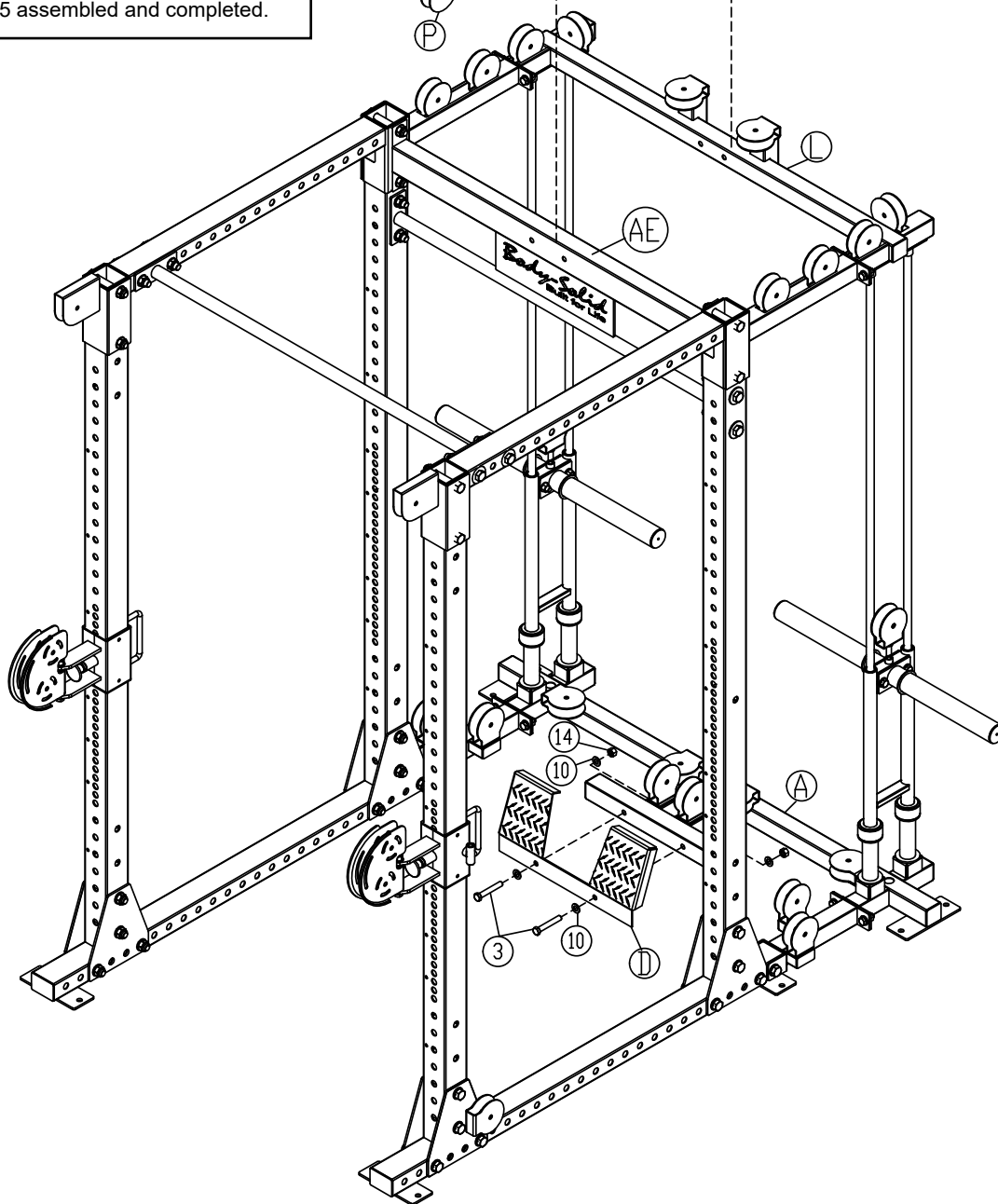
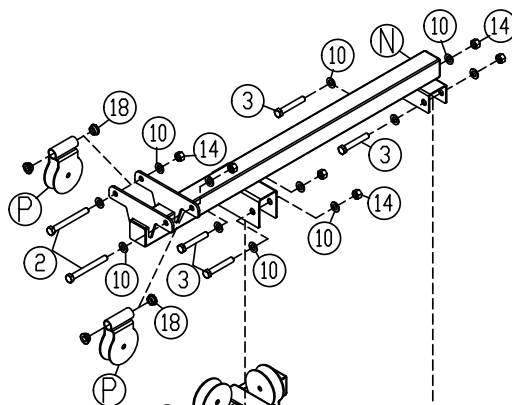

**STEP****6**

**Be careful to assemble all components in the sequence they are presented.**

**NOTE:**

**Wrench tighten ALL hardware at the end of STEP 6A. Some components may be pre-assembled. Nylon lock nuts will not fully screw onto bolts, they must be wrench tighten to fully go on.**

**NOTE #1:** Some of the components are hidden to better illustrate the cable routing.

**NOTE #2:** In order to route the Cable (#24) correctly, please disassemble Cable Connector (#26) and Accessory Connector (#27) from one end of the Cable (#24) by removing two M6x12mm Button Head Cap Screws (#8)

After the Cable (#24) is installed in the machine, please assemble back the Cable Connector (#26) and Accessory Connector (#27) to the Cable (#24) using two M6x12mm Button Head Cap Screws (#8)

**6A.** Route Top Cable (#24) while installing Eleven  $\varnothing 90$ mm Pulleys (#22) on the left side of the machine as shown in STEP 6 drawing using:

11 - (#6) M10x50mm Hex Head Bolt

22 - (#11) M10 Washer

11 - (#15) M10 Nylon Lock Nut

1 - (Q) Floating Pulley Bracket

1 - (R) Pulley Bracket



**STEP**  
**6**

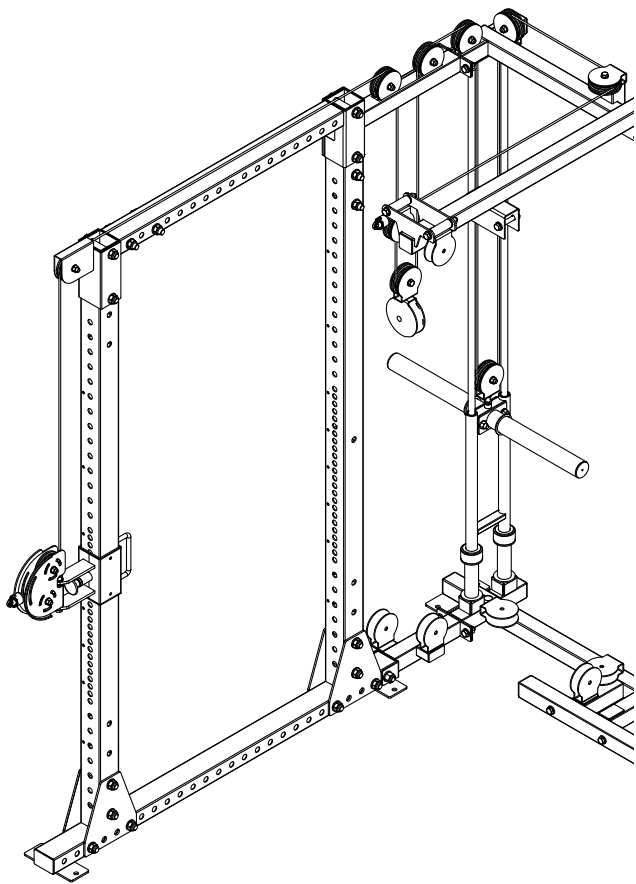

Above shows Step 6 assembled and completed.

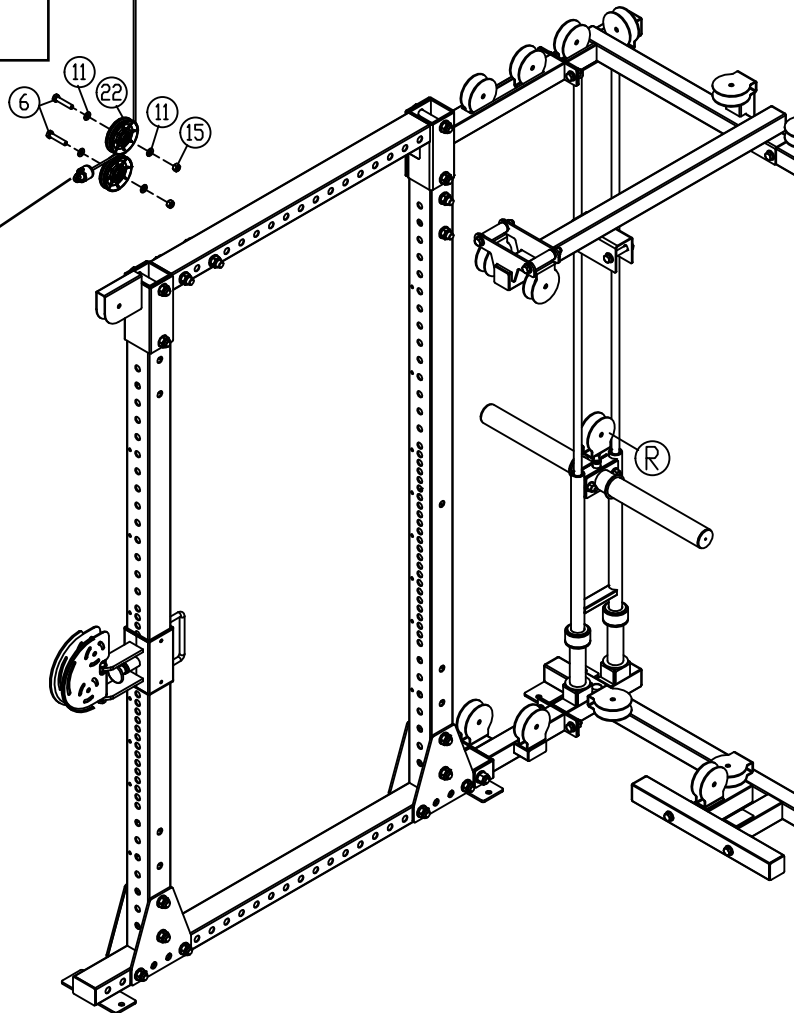
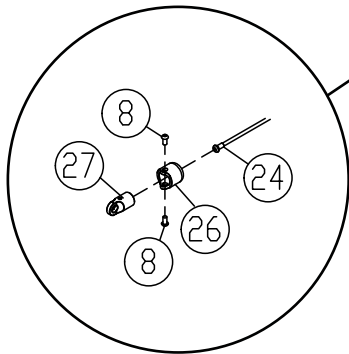
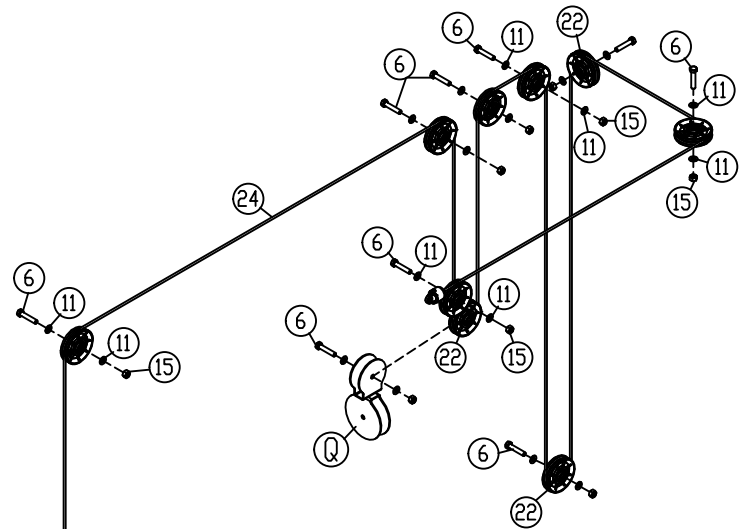

**STEP****7**

**Be careful to assemble all components in the sequence they are presented.**

**NOTE:**

**Wrench tighten ALL hardware at the end of STEP 7C. Some components may be pre-assembled. Nylon lock nuts will not fully screw onto bolts, they must be wrench tighten to fully go on.**

**NOTE: Some of the components are hidden to better illustrate the cable routing.**

**7A.** Route Low Cable (#25) while installing Six ø90mm Pulleys (#22) and One ø117mm Pulley (#23) on the left side of the machine as shown in STEP 7 drawing using:

7 - (#6) M10x50mm Hex Head Bolt

14 - (#11) M10 Washer

7 - (#15) M10 Nylon Lock Nut

1 - (Q) Floating Pulley Bracket

**7B.** Attach Low Cable (#25) to Cable Connector Bolt (#28) and screw in two M12 Hex Nuts (#16) into Cable Connector Bolt (#28)

**7C.** Attach the Cable Connector Bolt (#28) of the Low Cable (#25) to the Side of the Left Sliding Handle (T) and secure the Cable (#25) by wrench tightening the two M12 Hex Nuts (#30)

**STEP**  
**7**

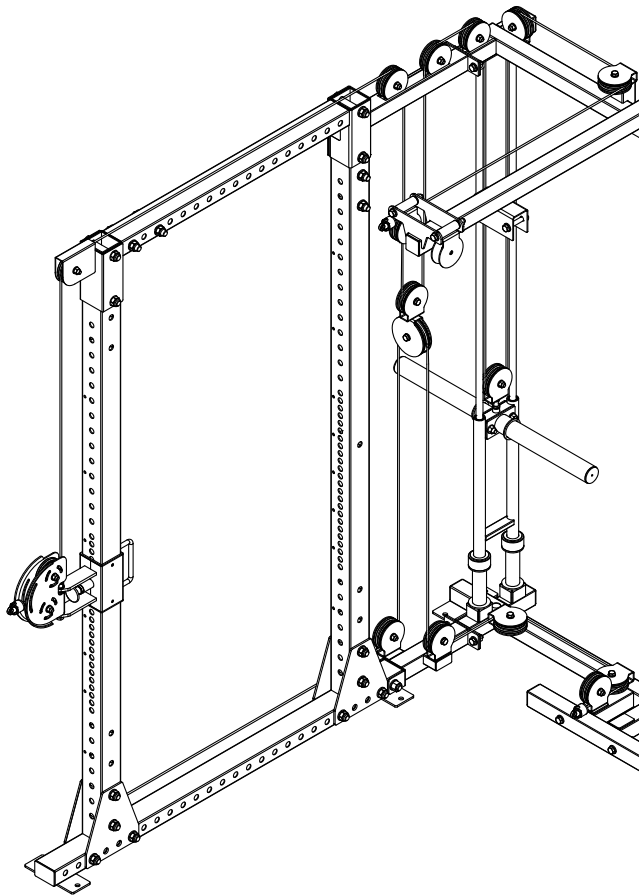

Above shows Step 7 assembled and completed.

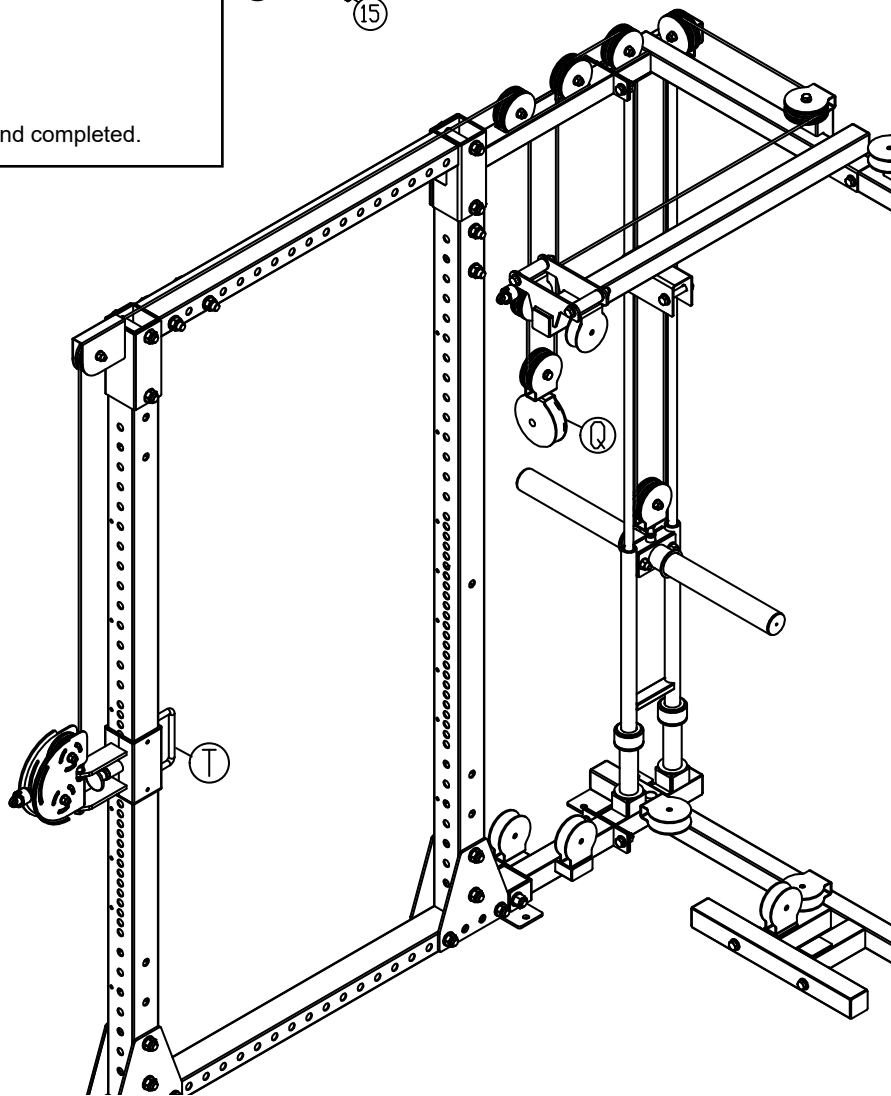
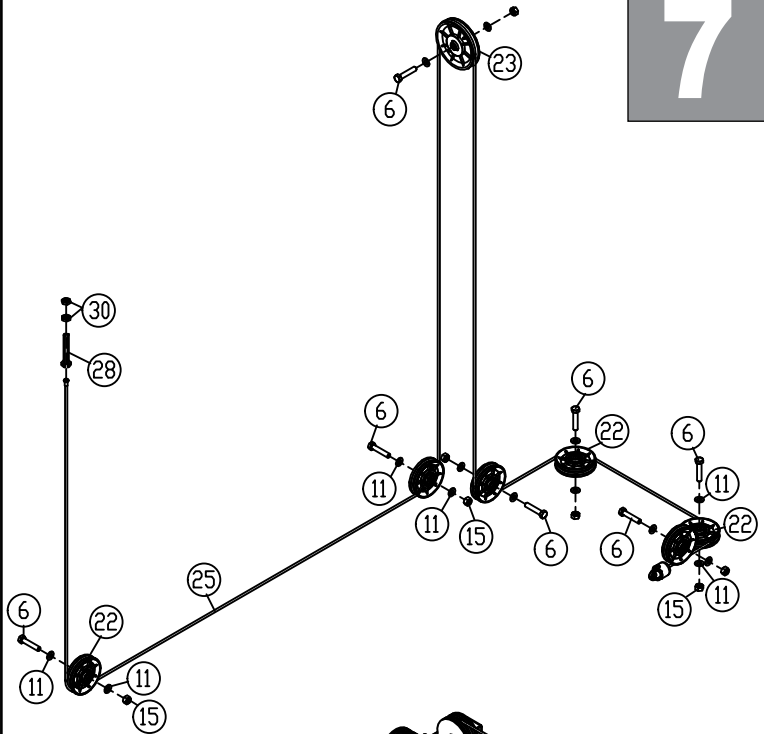

**STEP****8**

**Be careful to assemble all components in the sequence they are presented.**

**NOTE:**

**Wrench tighten ALL hardware at the end of STEP 8A. Some components may be pre-assembled. Nylon lock nuts will not fully screw onto bolts, they must be wrench tighten to fully go on.**

**NOTE #1:** Some of the components are hidden to better illustrate the cable routing.

**NOTE #2:** In order to route the Cable (#24) correctly, please disassemble Cable Connector (#26) and Accessory Connector (#27) from one end of the Cable (#24) by removing two M6x12mm Button Head Cap Screws (#8)

After the Cable (#24) is installed in the machine, please assemble back the Cable Connector (#26) and Accessory Connector (#27) to the Cable (#24) using two M6x12mm Button Head Cap Screws (#8)

**8A.** Route Top Cable (#24) while installing Eleven ø90mm Pulleys (#22) on the right side of the machine as shown in STEP 8 drawing using:

11 - (#6) M10x50mm Hex Head Bolt

22 - (#11) M10 Washer

11 - (#15) M10 Nylon Lock Nut

1 - (Q) Floating Pulley Bracket

1 - (R) Pulley Bracket

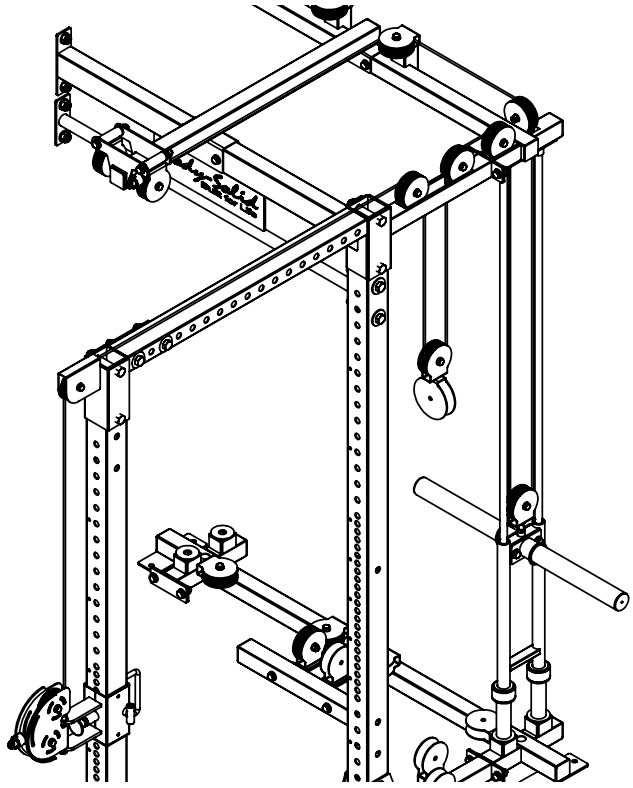

Above shows Step 8 assembled and completed.

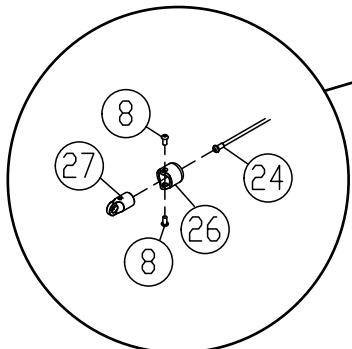
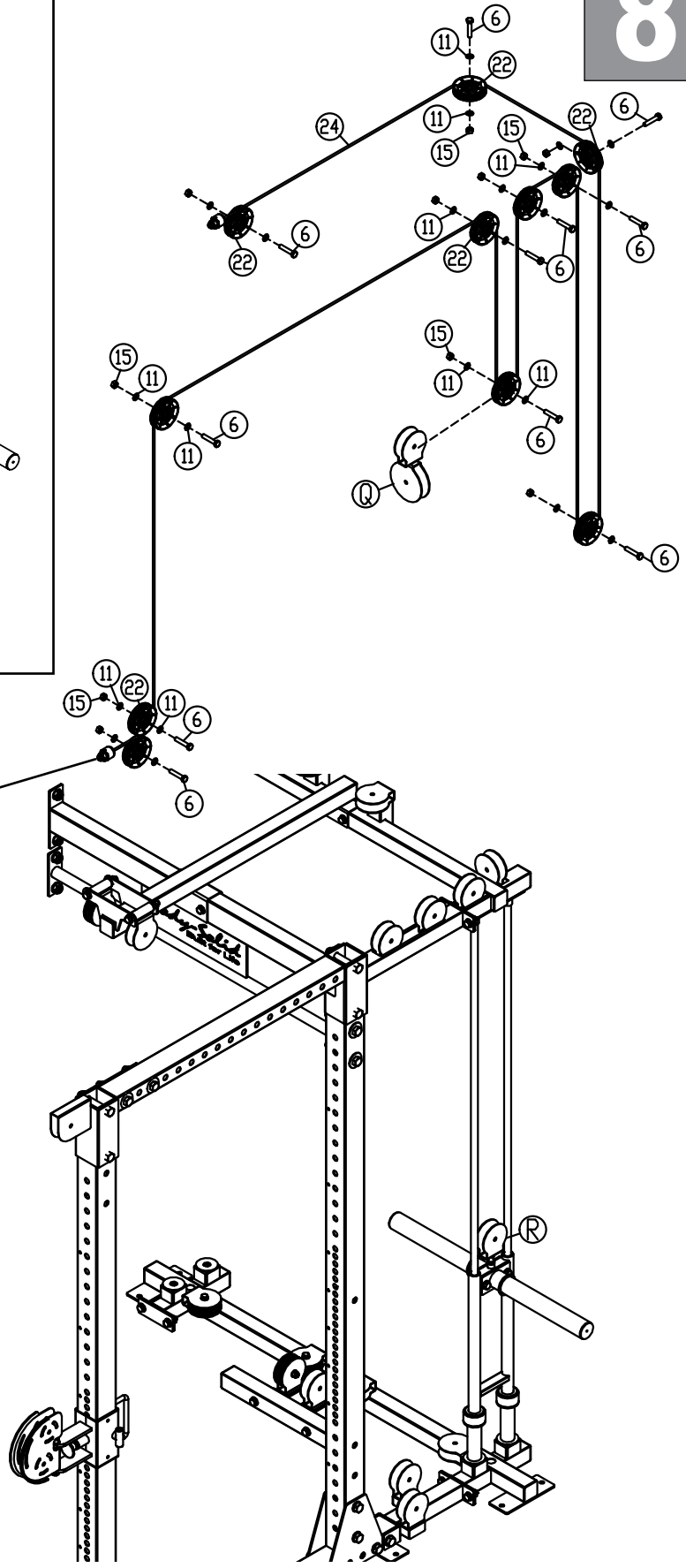

**STEP****9**

**Be careful to assemble all components in the sequence they are presented.**

**NOTE:**

**Wrench tighten ALL hardware at the end of STEP 9C. Some components may be pre-assembled. Nylon lock nuts will not fully screw onto bolts, they must be wrench tighten to fully go on.**

**NOTE: Some of the components are hidden to better illustrate the cable routing.**

**9A.** Route Low Cable (#25) while installing Six ø90mm Pulleys (#22) and One ø117mm Pulley (#23) on the Right side of the machine as shown in STEP 9 drawing using:

7 - (#6) M10x50mm Hex Head Bolt

14 - (#11) M10 Washer

7 - (#15) M10 Nylon Lock Nut

1 - (Q) Floating Pulley Bracket

**9B.** Attach Low Cable (#25) to Cable Connector Bolt (#28) and screw in two M12 Hex Nuts (#16) into Cable Connector Bolt (#28)

**9C.** Attach the Cable Connector Bolt (#28) of the Low Cable (#25) to the Side of the Right Sliding Handle (T) and secure the Cable (#25) by wrench tightening the two M12 Hex Nuts (#30)

**STEP**  
**9**

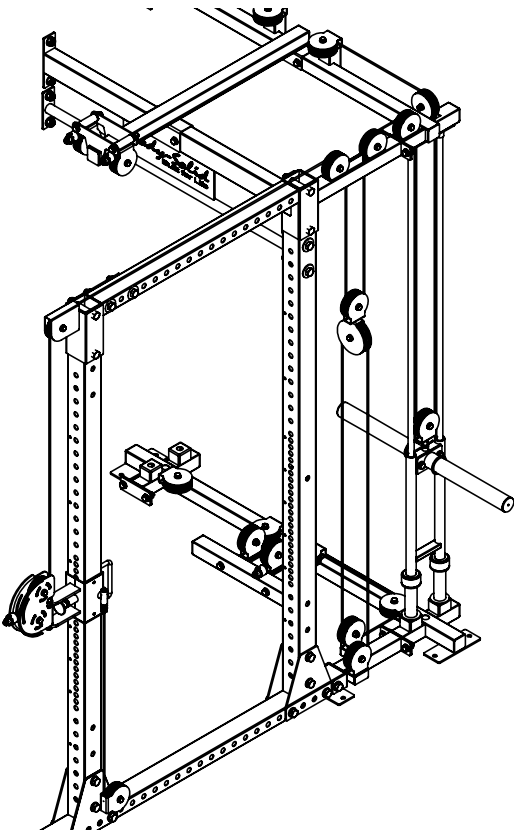

Above shows Step 9 assembled and completed.

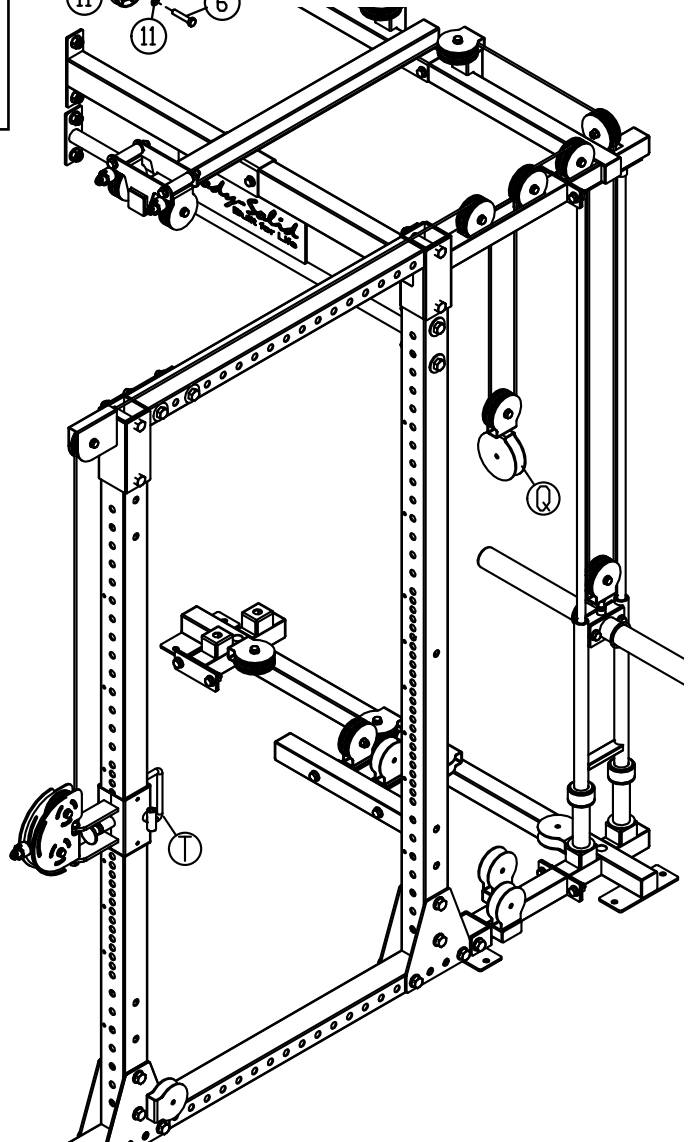
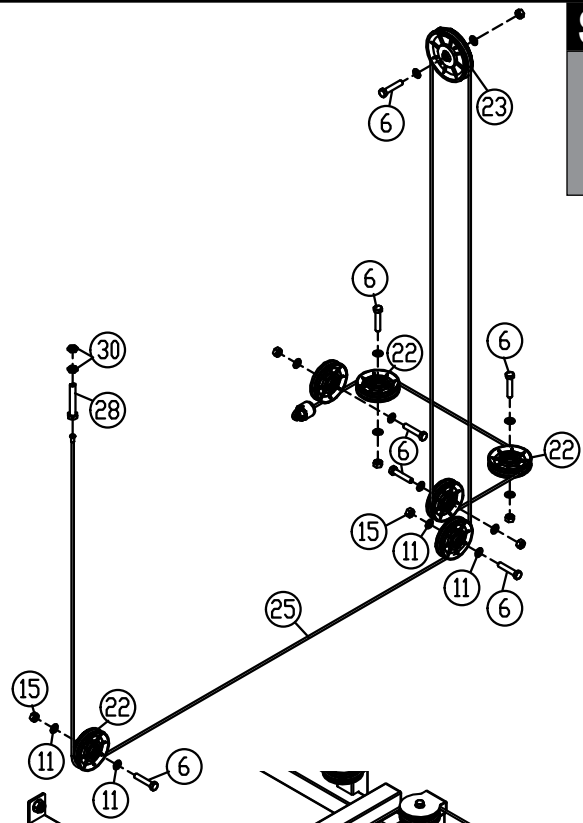

**STEP****10**

**Be careful to assemble all components in the sequence they are presented.**

**NOTE:**

**Some components may be pre-assembled. Nylon lock nuts will not fully screw onto bolts, they must be wrench tightened to fully go on.**

**10A.** Attach Strap Handles (**#35**) to Top Cables (**#24**).

**10B.** Attach Lat Bar (**X**) to Top Cables (**#24**).

**10C.** Attach Short Bar (**Y**) or Ankle Strap (**#37**) to Low Cables (**#25**).



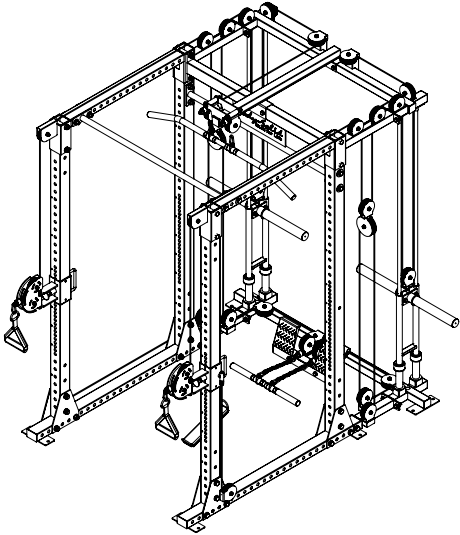

Above shows Step 8 assembled and completed.

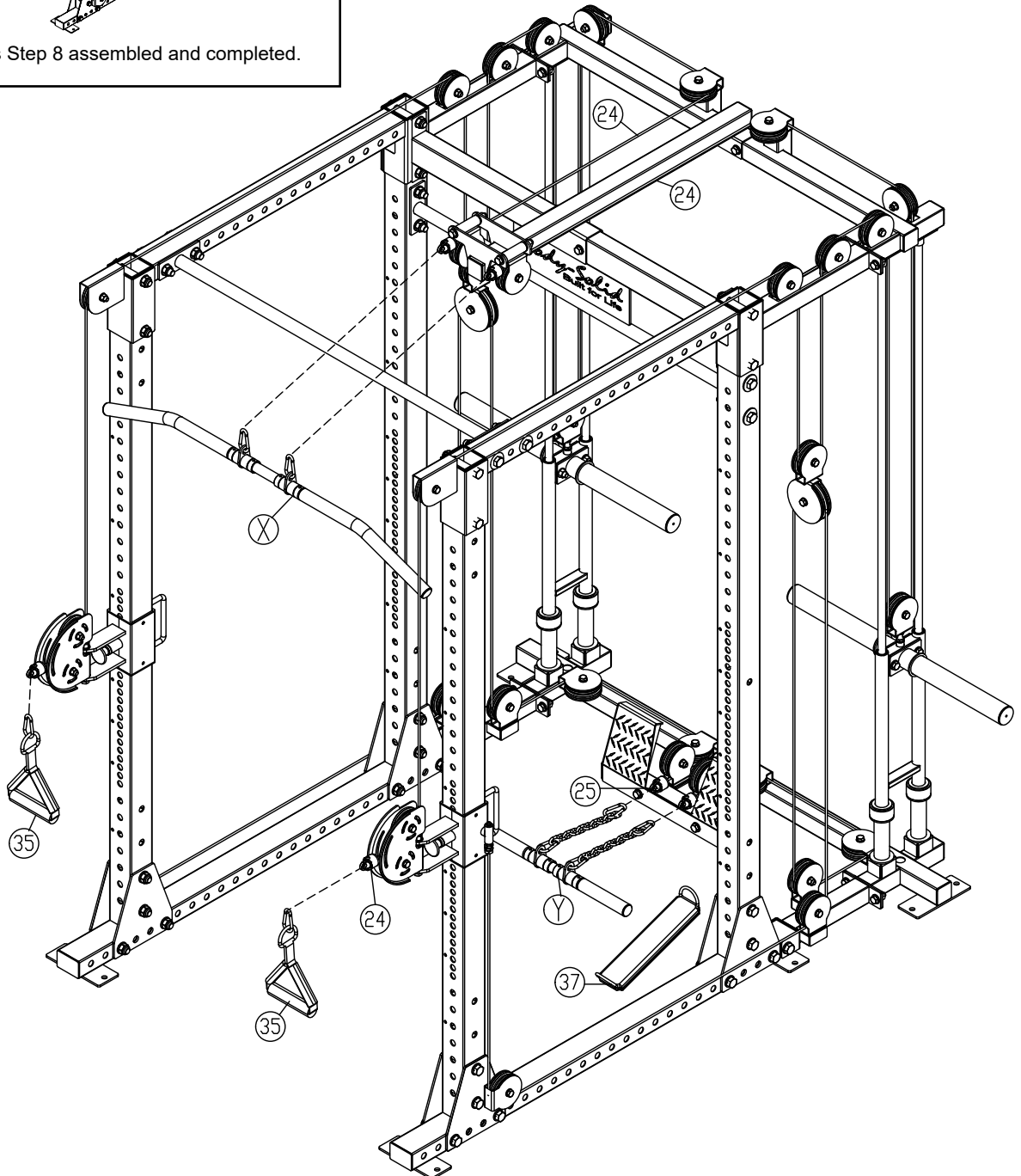

# GPRFT Exploded View (1)

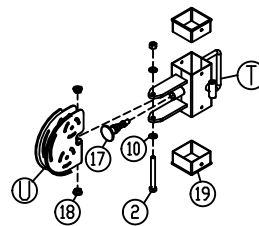
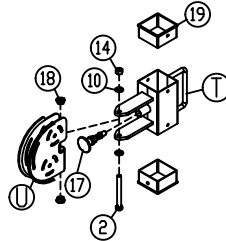
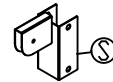
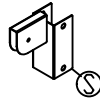
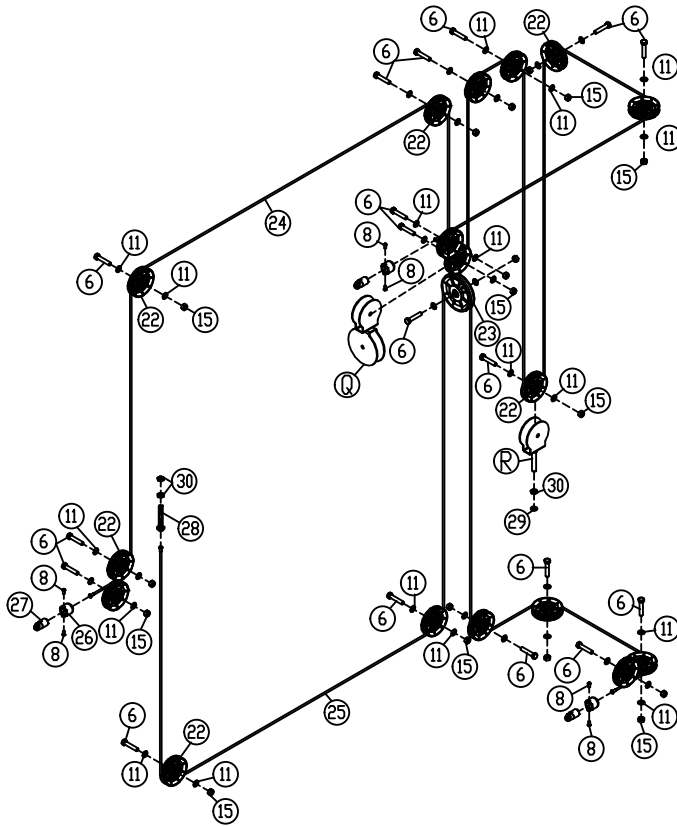

# GPRFT Exploded View (2)

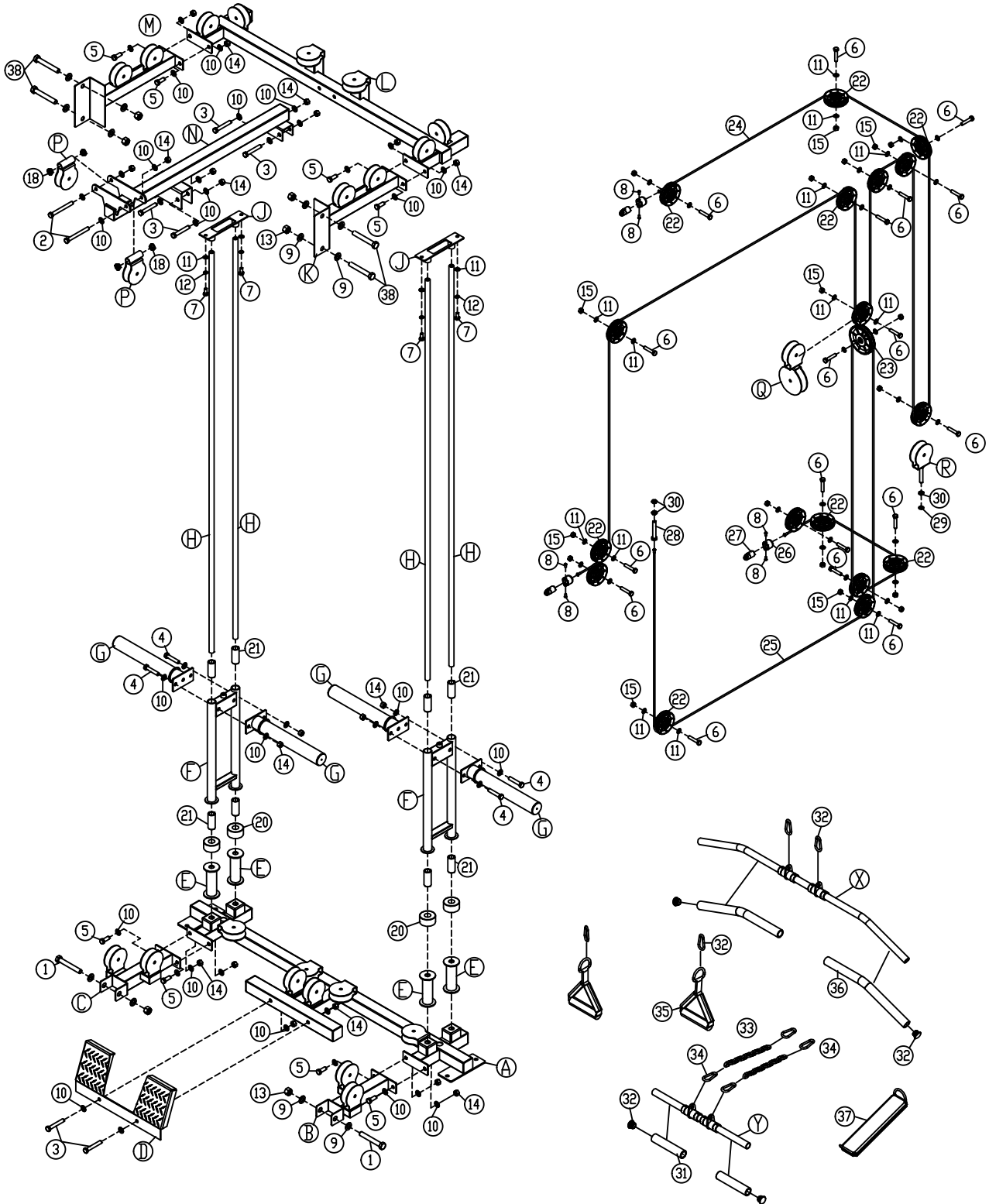



# GPRFT

PLEASE WRITE YOUR SERIAL NUMBER IN THE BOXES BELOW

S/N # 018266----

1900 S. Des Plaines Ave.  
Forest Park, IL 60130  
Phone:(708)427-3555  
Fax:(708)427-3556  
Hours: M-F 8:30 - 5:00 CST

*www.bodysolid.com*