

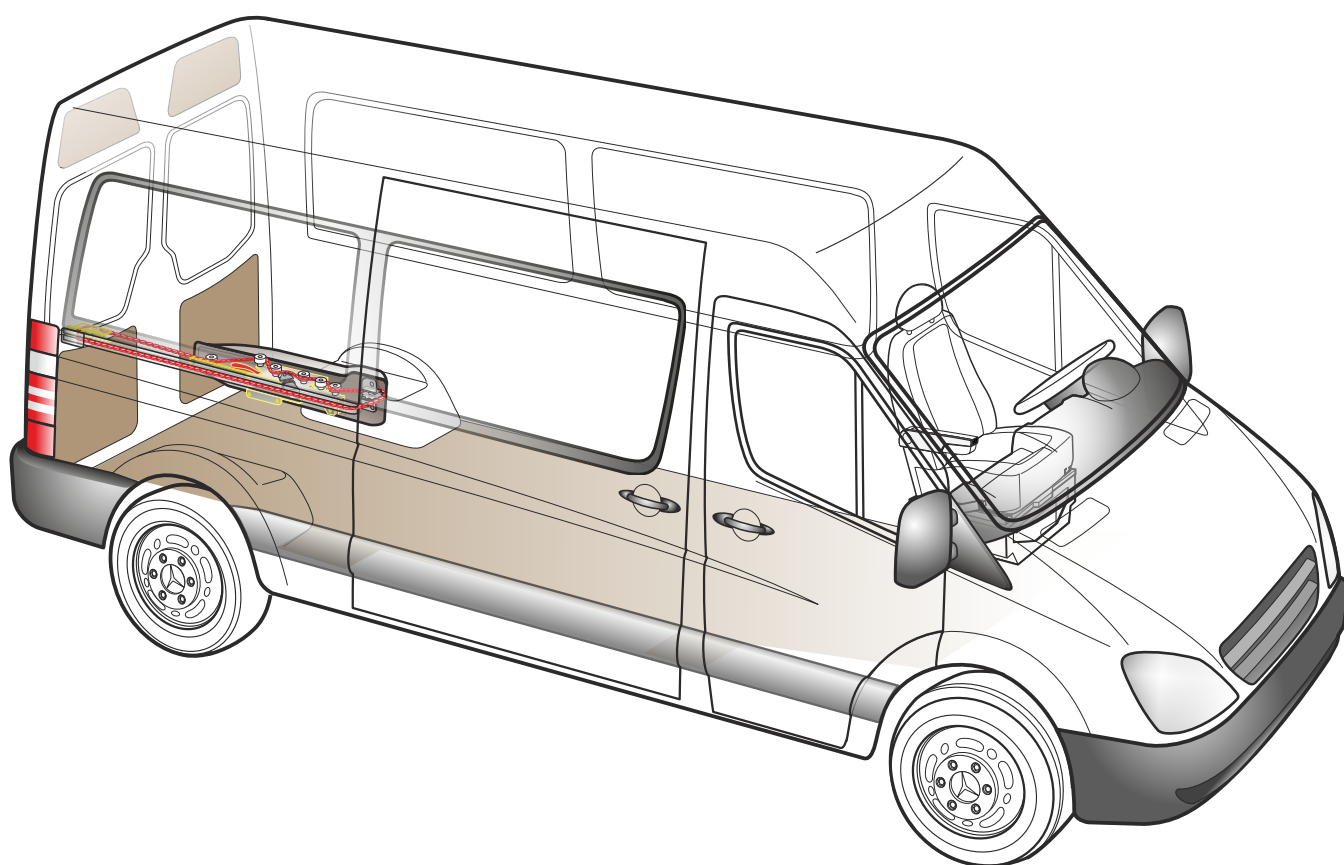
Power Door & Step



PowerDoorAndStep.com

888.928.8000

Mercedes Sprinter
VW CRAFTER



ASD Automatic Sliding Door

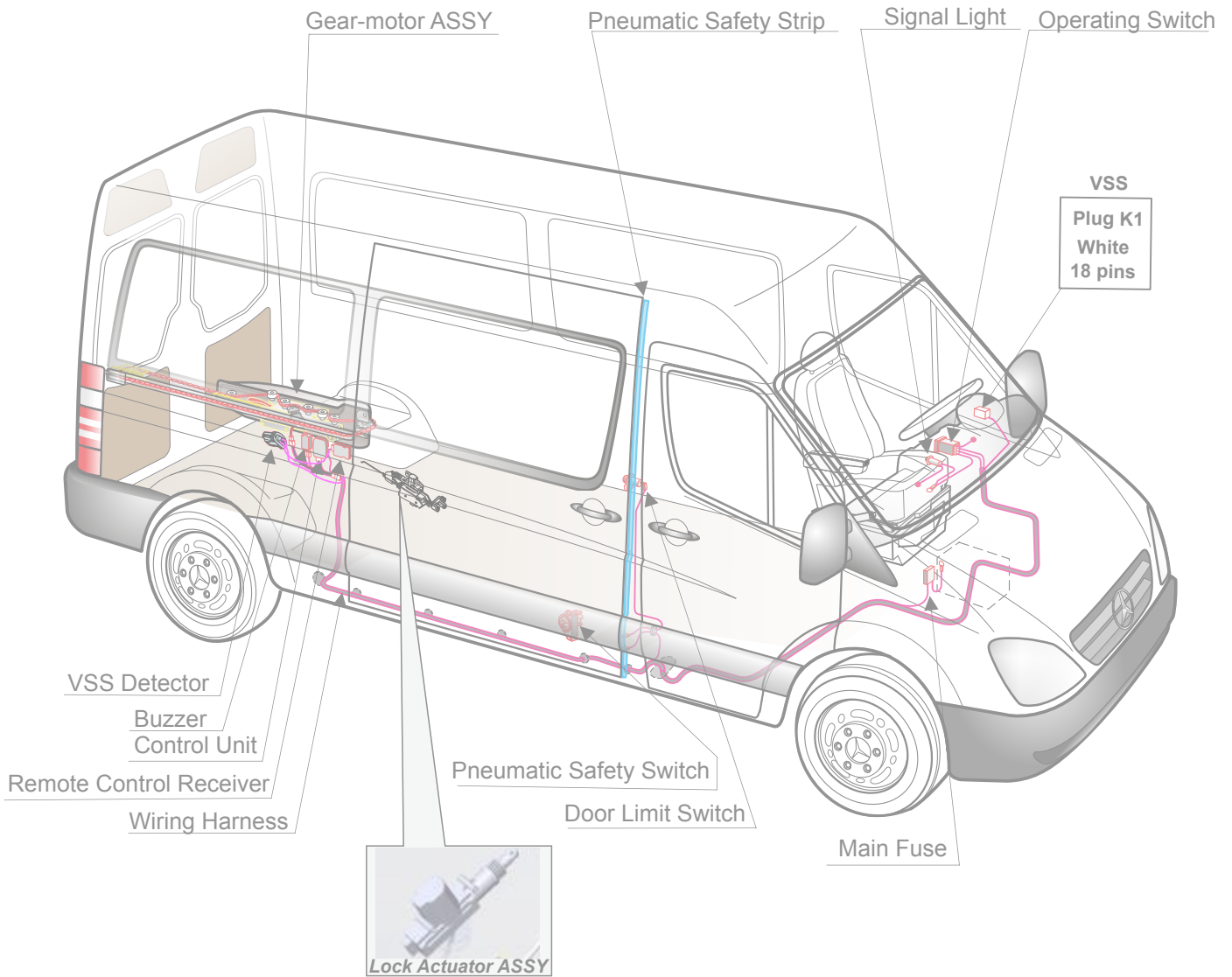
PN: 015-0003-DL Kombi standard (wheelbase-3.665)

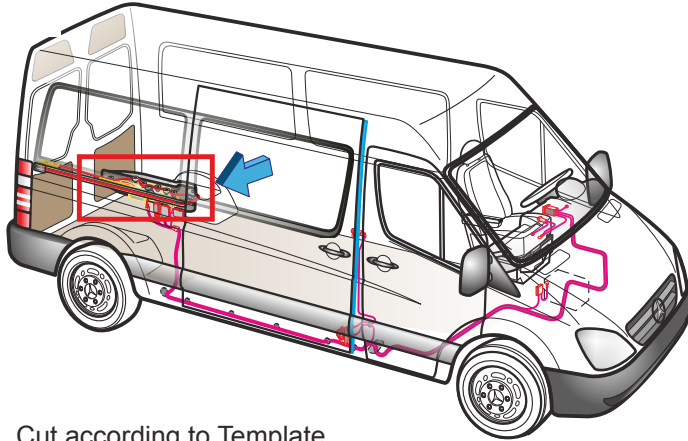
Kombi long and super long (wheelbase-4.325)

Original Door latch mechanism
& operation with handles

Recommendation

Please print this instruction manual in **color**





Cut according to Template

Drill $\varnothing 7$ (x2)

Supplied Template

Cut according to dimensions

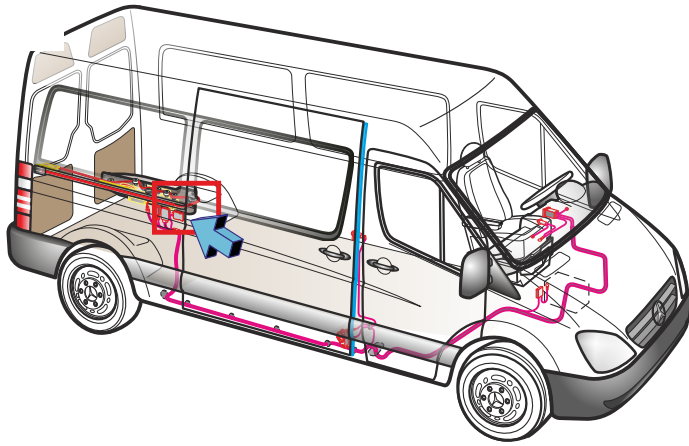


55

70

20



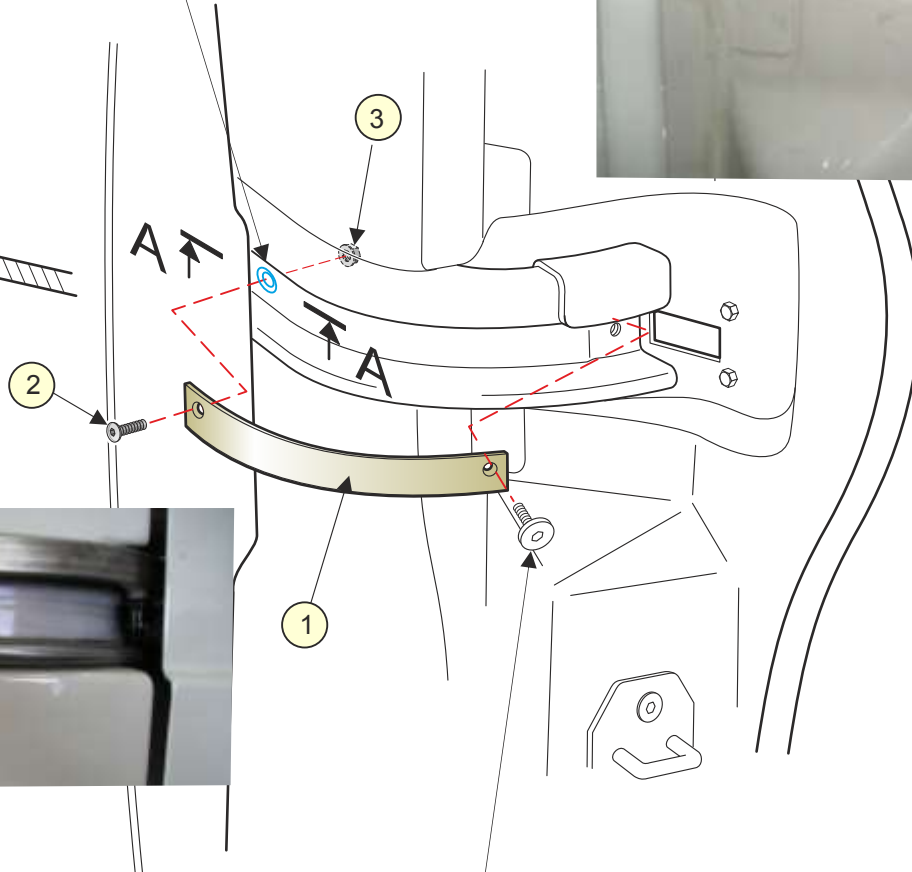


Drill $\varnothing 4.5$ according to detail (25)



A-A

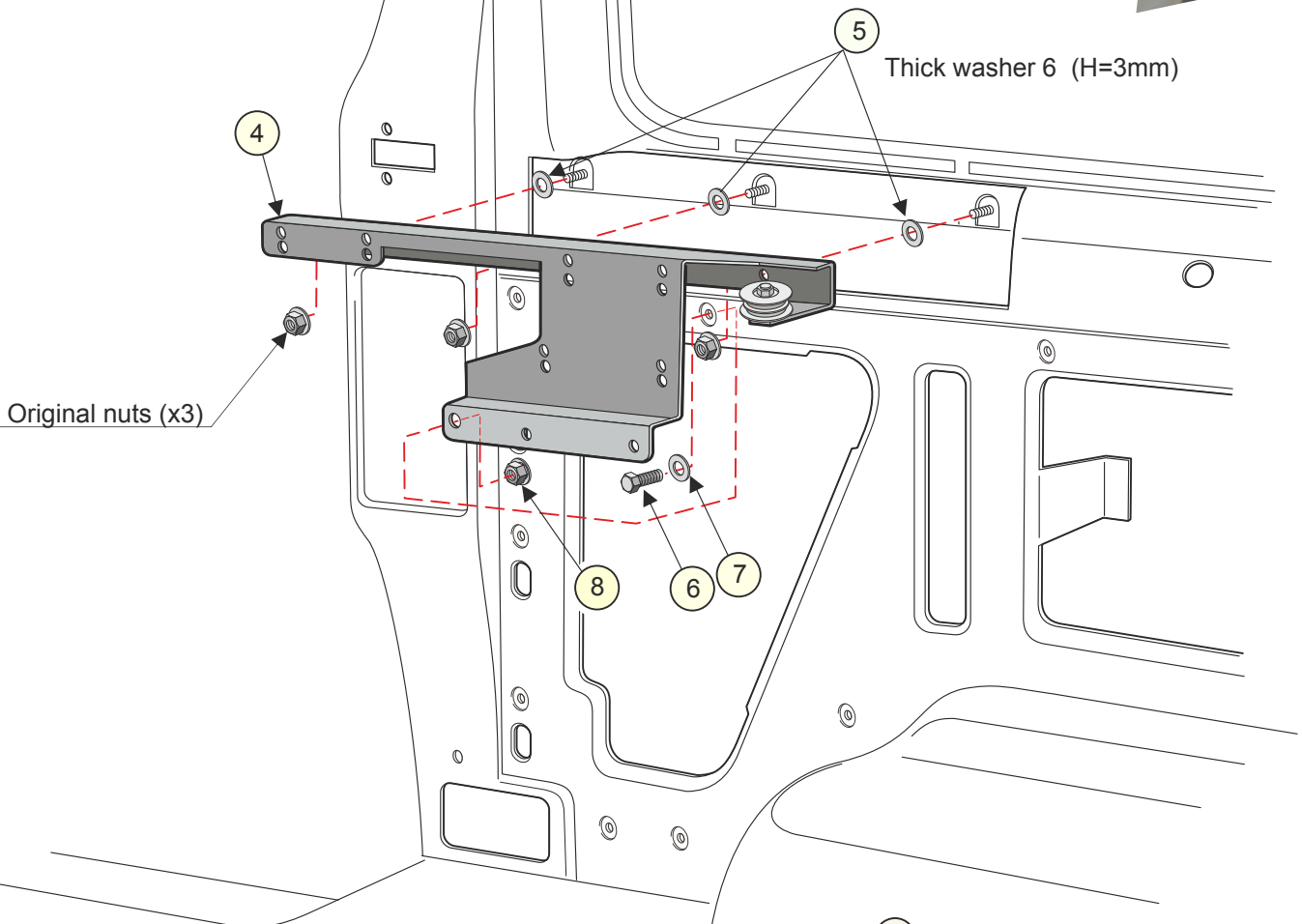
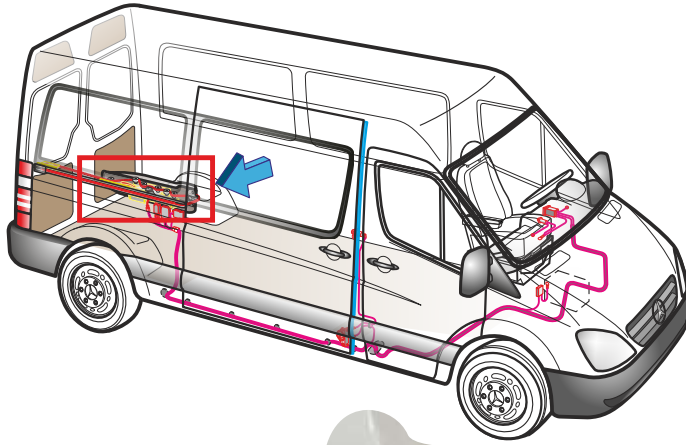
90°





4.5mm

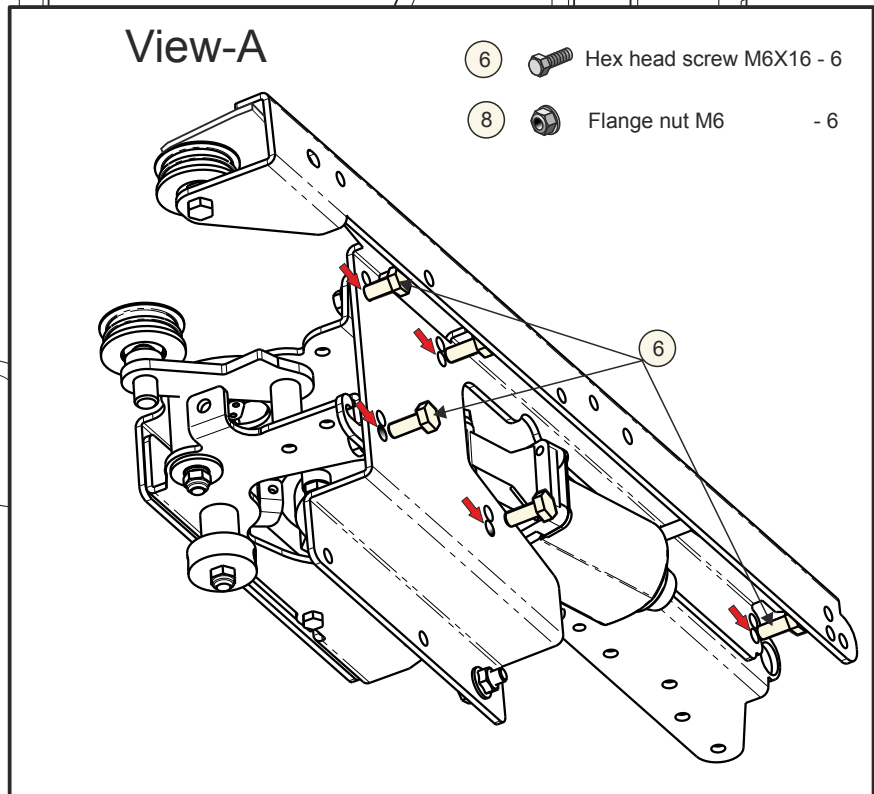
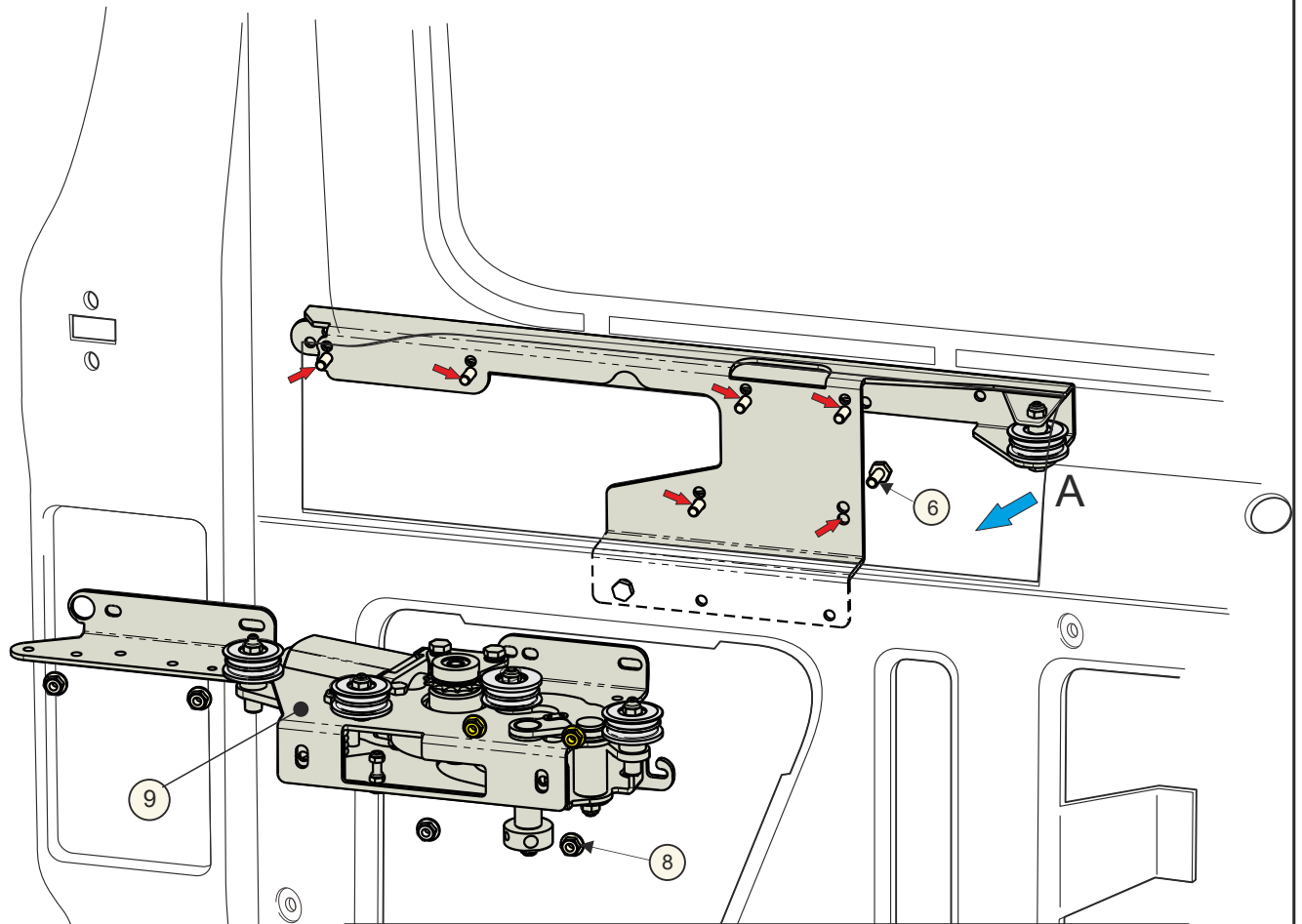


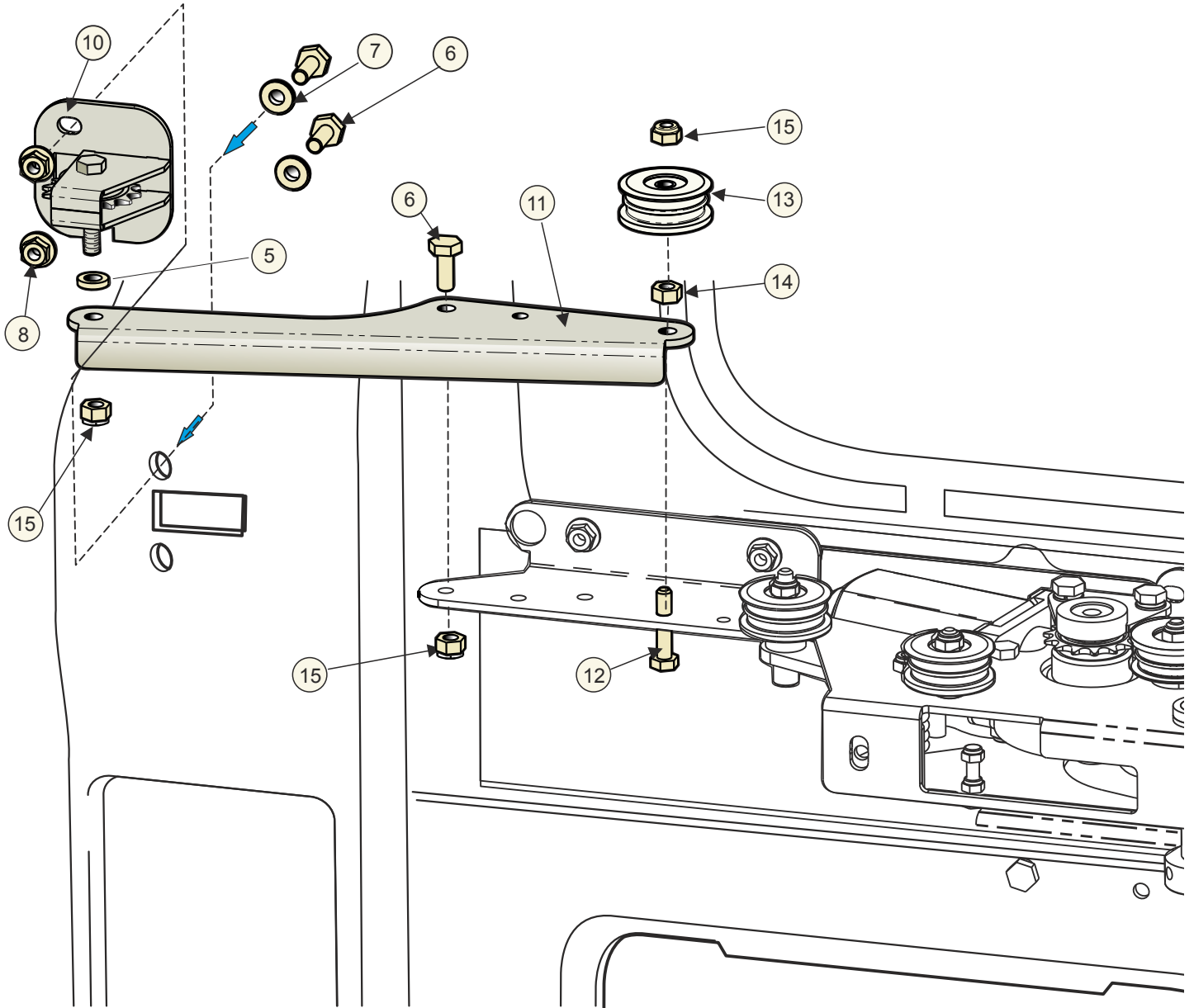
Original bolt

- 2  Socket flat head screw M4X20 - 1
- 3  Lock nut M4 - 1



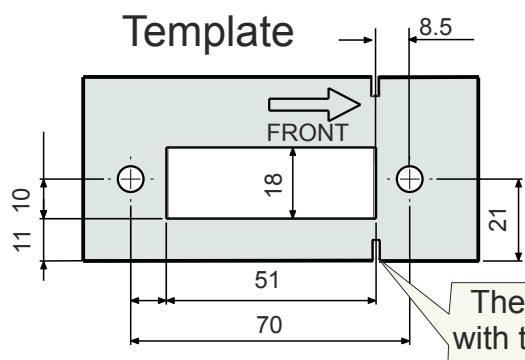
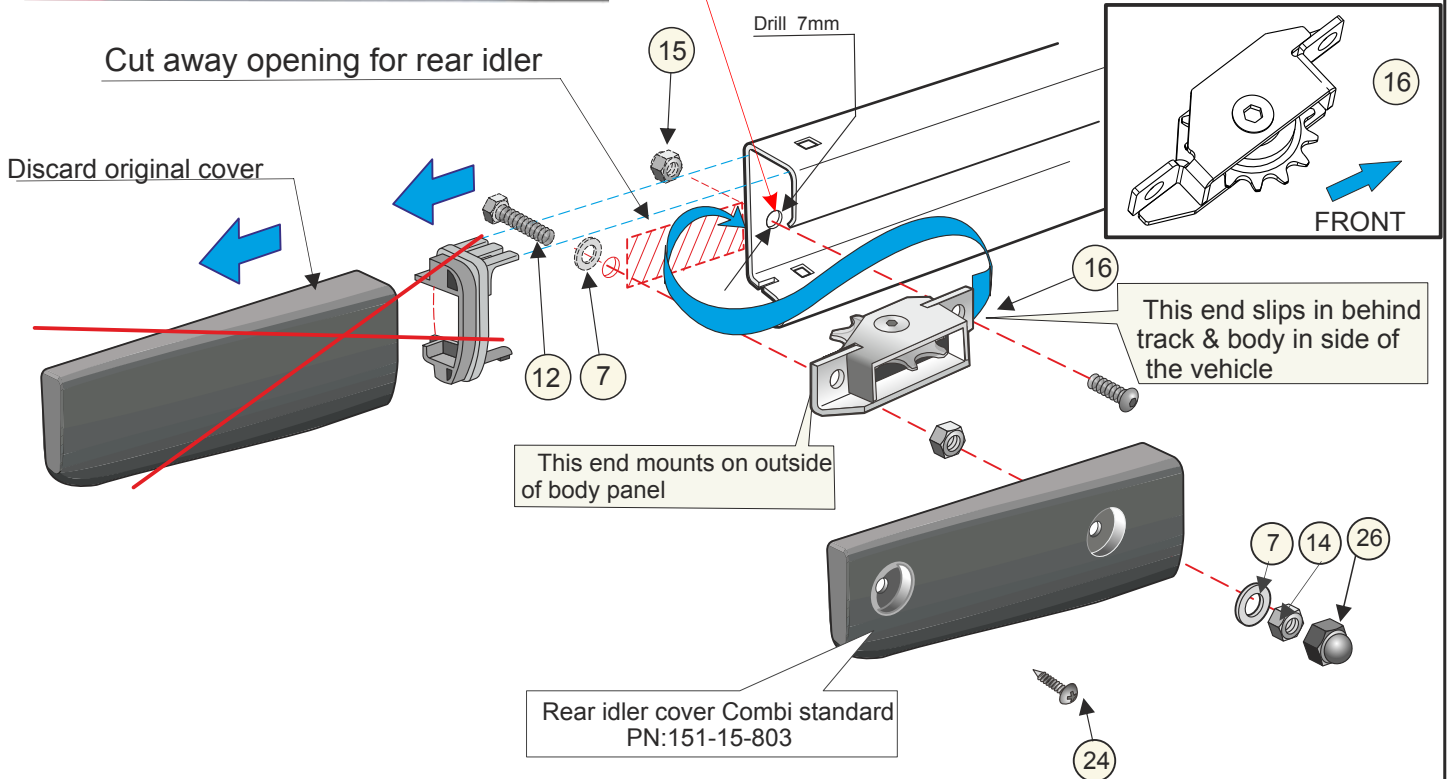
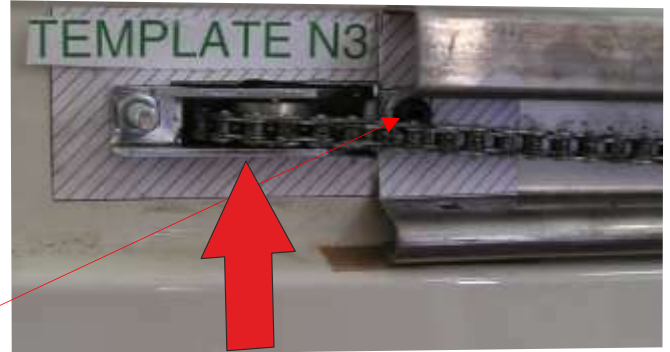
- | | | | |
|---|---------------------------------------------------------------------------------------|----------------------|-----|
| 5 |  | Thick Washer 6 | - 3 |
| 6 |  | Hex head screw M6X16 | - 1 |
| 7 |  | Washer 6 | - 1 |
| 8 |  | Flange nut M6 | - 1 |





		QTY
6		Hex head screw M6X16 - 3
5		Washer 6 - 2
8		Flange nut M6 - 2
12		Hex head screw M6X30 - 1
14		Nut M6 - 1
15		Lock nut M6 - 3

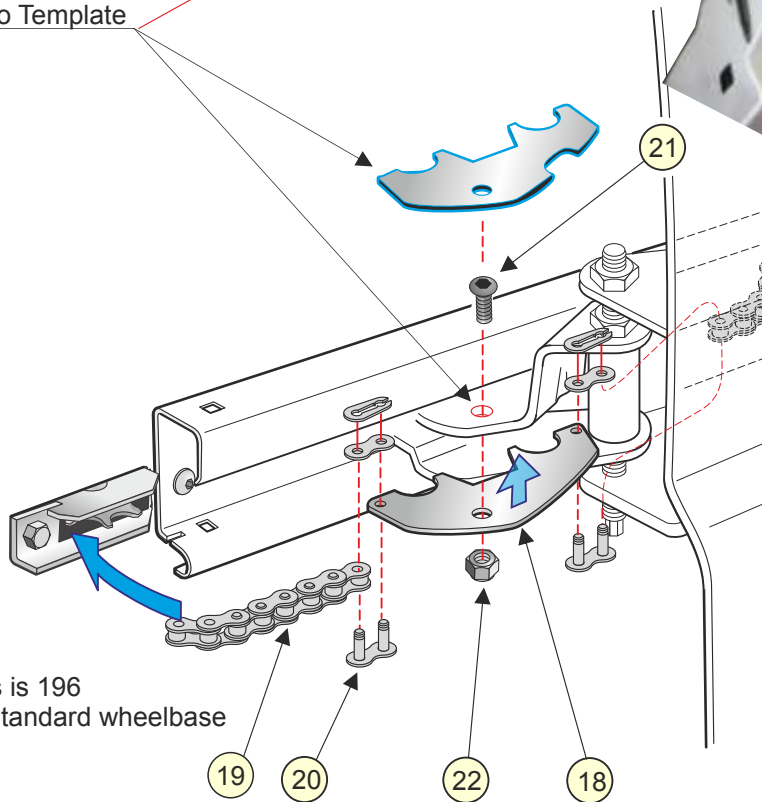
Kombi standard (wheelbase-3.665)
 PN: 015-0003



- | | | | |
|----|--|--------------------------------|-----|
| 17 | | Socket button head screw M6X16 | - 1 |
| 7 | | Washer 6 | - 2 |
| 15 | | Lock nut M6 | - 2 |
| 12 | | Hex head screw M6X30 | - 1 |
| 14 | | Nut M6 | - 1 |
| 26 | | Nut's Plastic Cover | - 1 |
| 24 | | Philips screw 5/8" | - 1 |



Drill $\varnothing 5$ according to Template



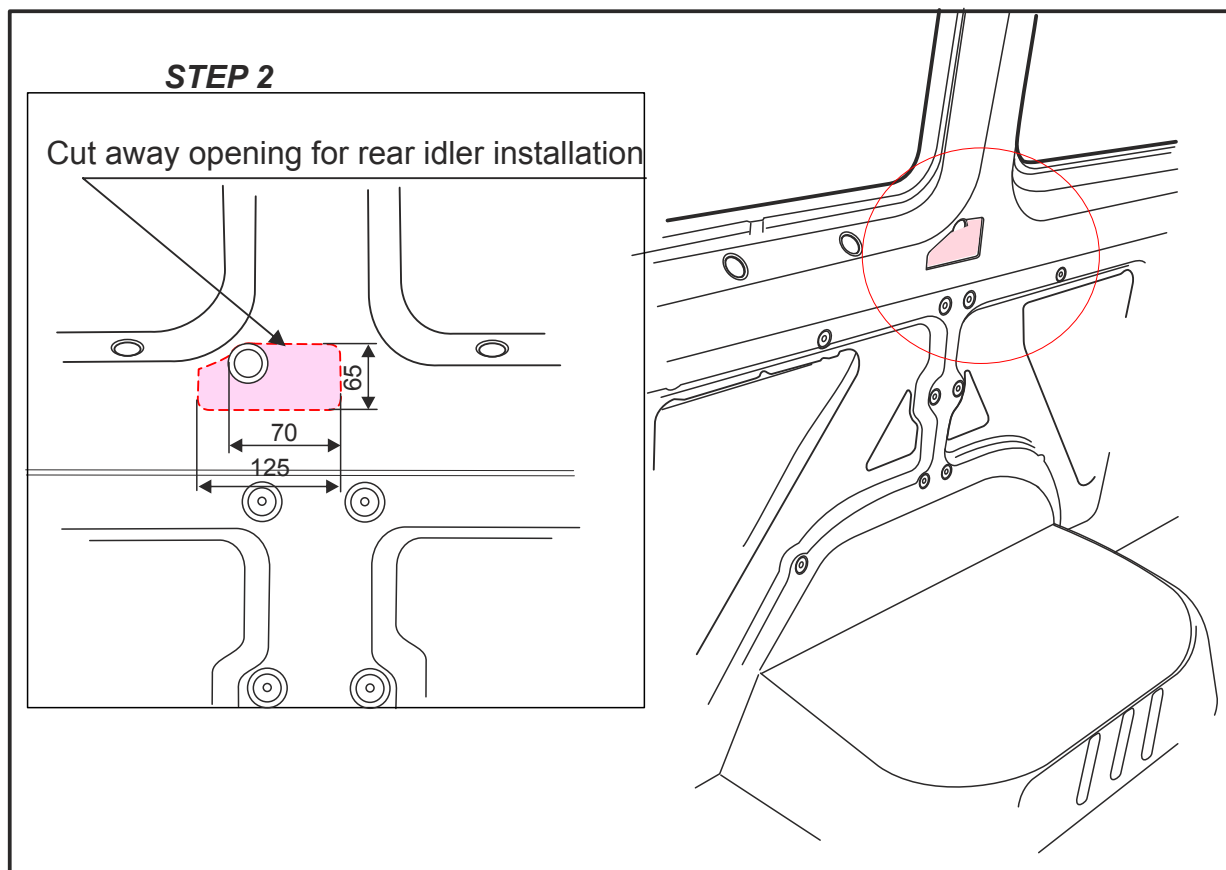
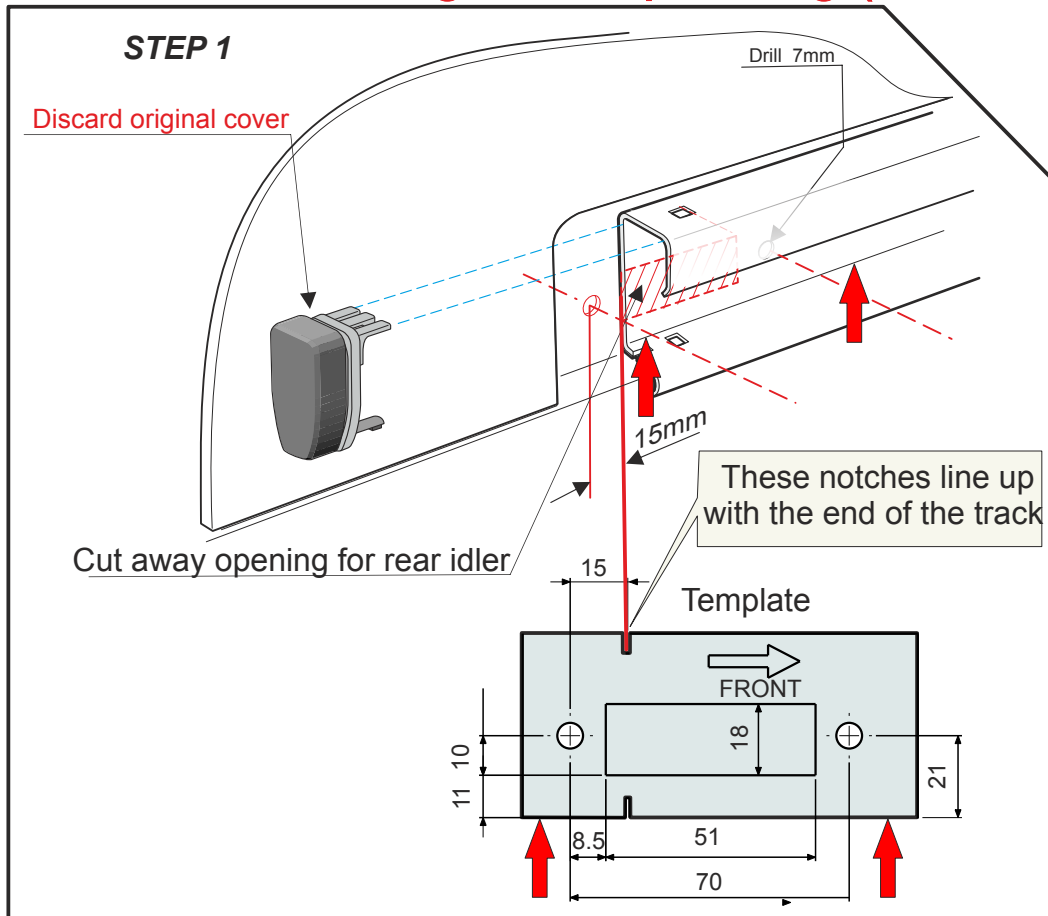
Note
 Number of chain links is 196
 (for vehicles: Kombi standard wheelbase
 and Delivery van)



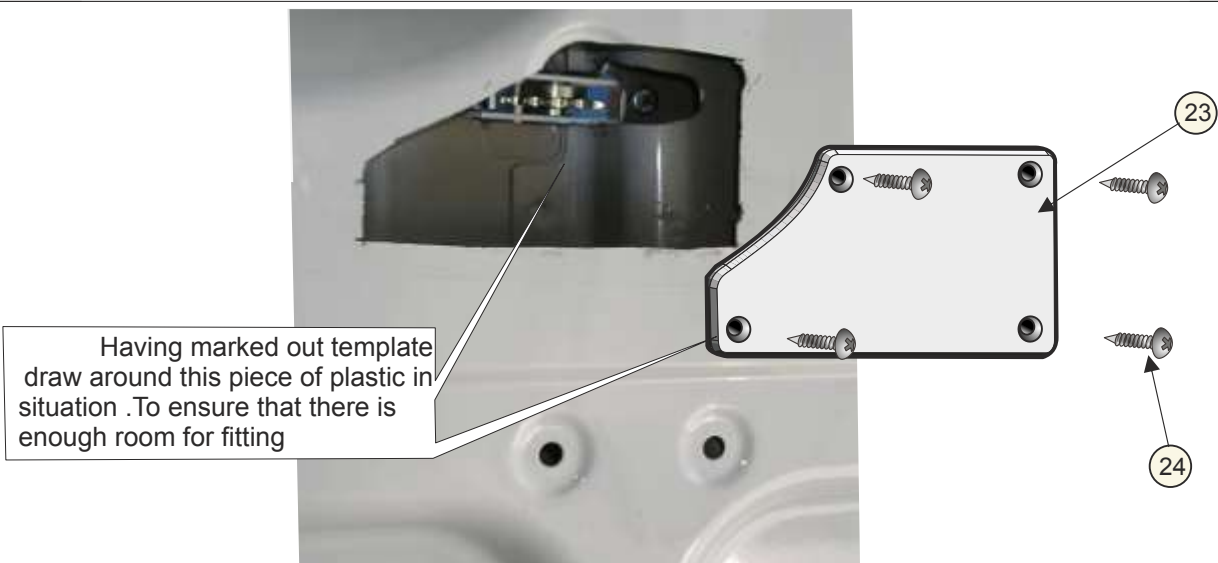
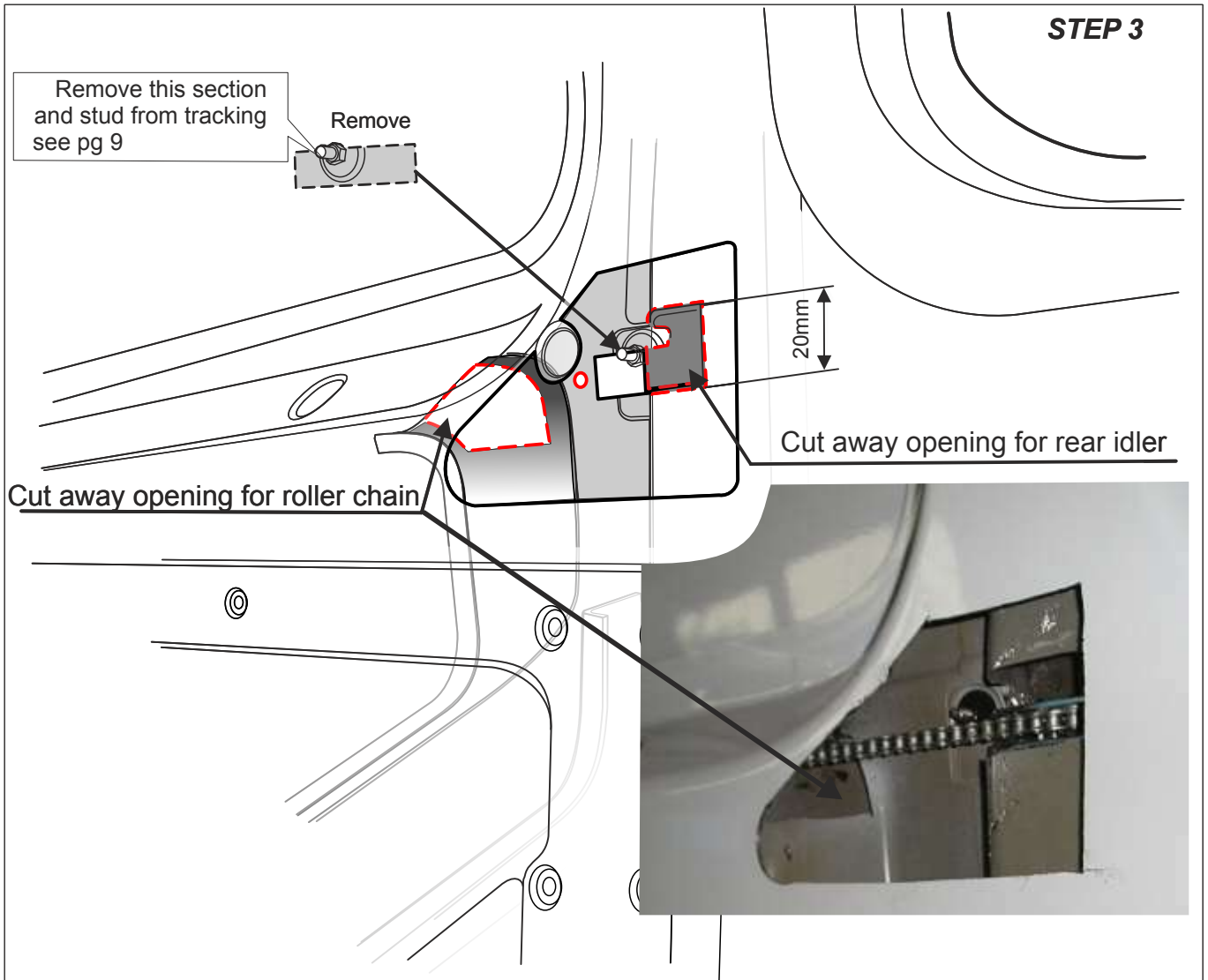
(21) Socket button head screw M5X16 - 1

(22) Lock nut M5 - 1

Kombi long and super long (wheelbase-4.325)

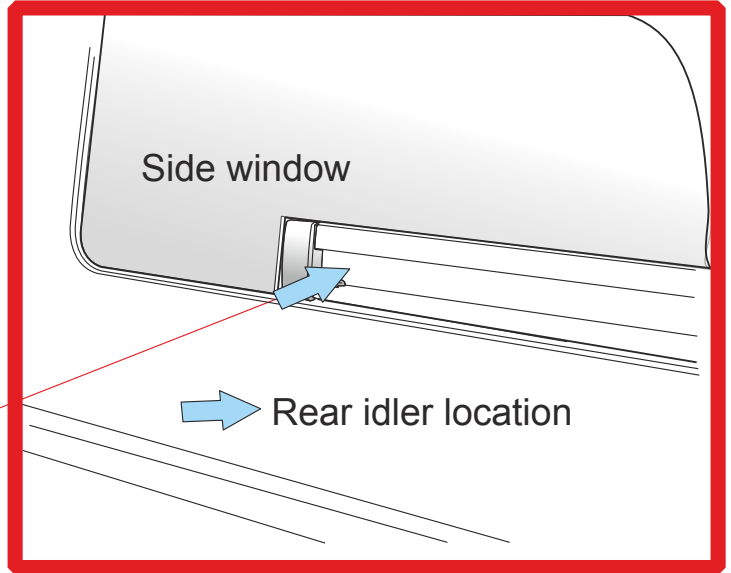


Kombi long and super long (wheelbase-4.325)



Kombi long and super long (wheelbase-4.325)

STEP 4



Loosen tracking bolts to remove end cap

Discard original cover

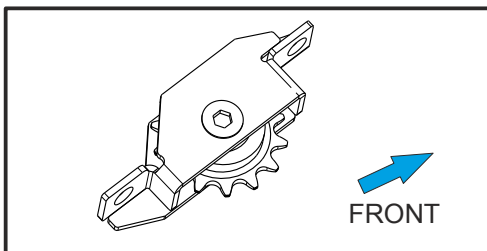
This end slips in behind track & body in side of the vehicle

Cut away opening for roller chain

Drill 7mm

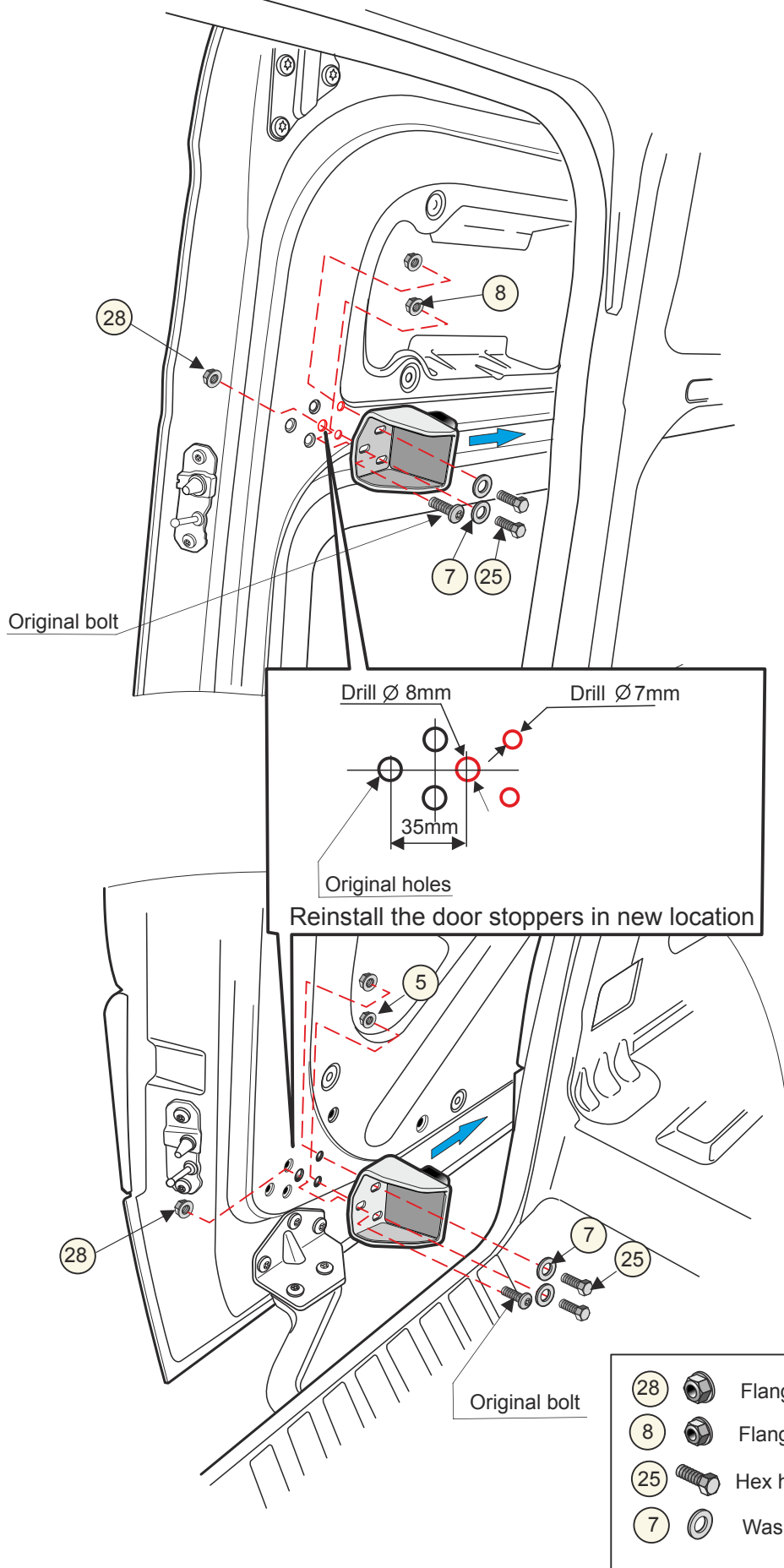
15mm

This end mounts on outside of body panel



- | | | | |
|----|--|--------------------------------|-----|
| 17 | | Socket button head screw M6X16 | - 1 |
| 7 | | Washer 6 | - 2 |
| 15 | | Lock nut M6 | - 2 |
| 12 | | Hex head screw M6X30 | - 1 |
| 14 | | Nut M6 | - 1 |
| 26 | | Nut's Plastic Cover | - 1 |

y Kombi long and super long (wheelbase-4.325)



Kombi long and super long (wheelbase-4.325)

Do not separate the cart from the door
Drill the hole on the spot

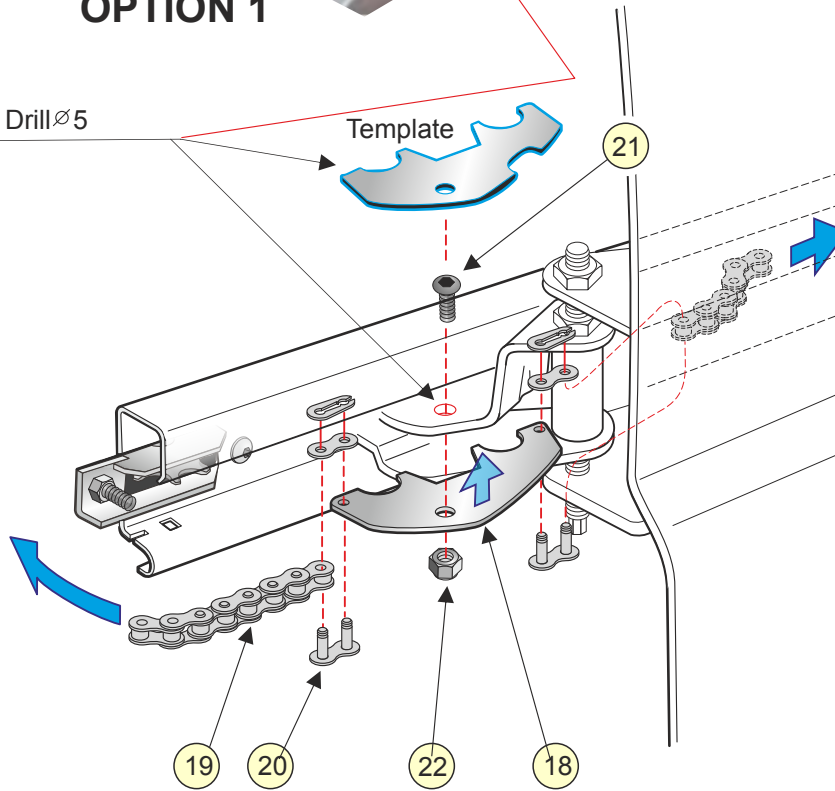


OPTION 1

Drill $\varnothing 5$

Template

21



OPTION 2

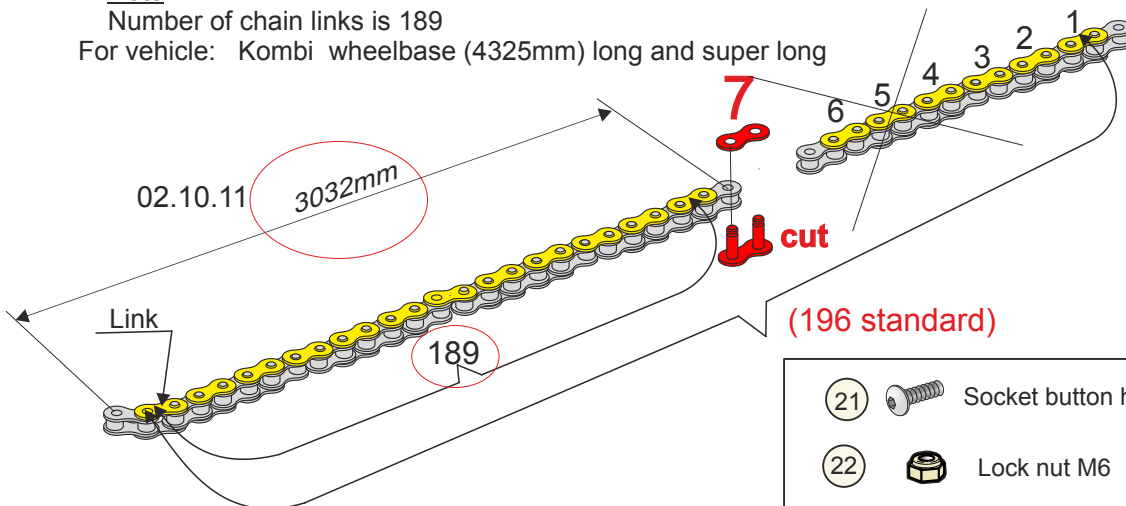


Chain Support
 PN:128-15-030

Note

Number of chain links is 189

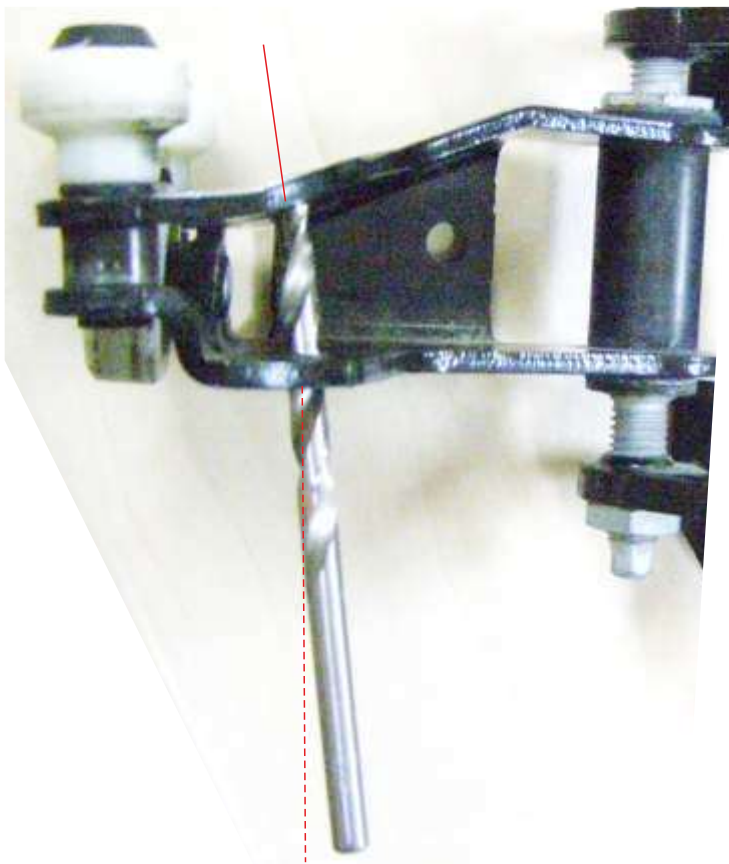
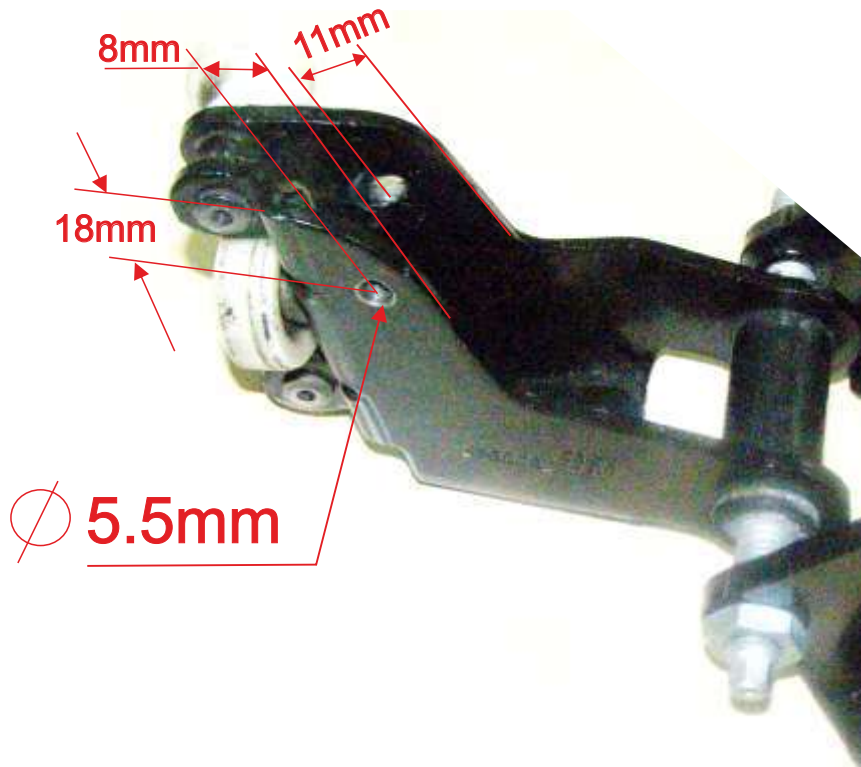
For vehicle: Kombi wheelbase (4325mm) long and super long

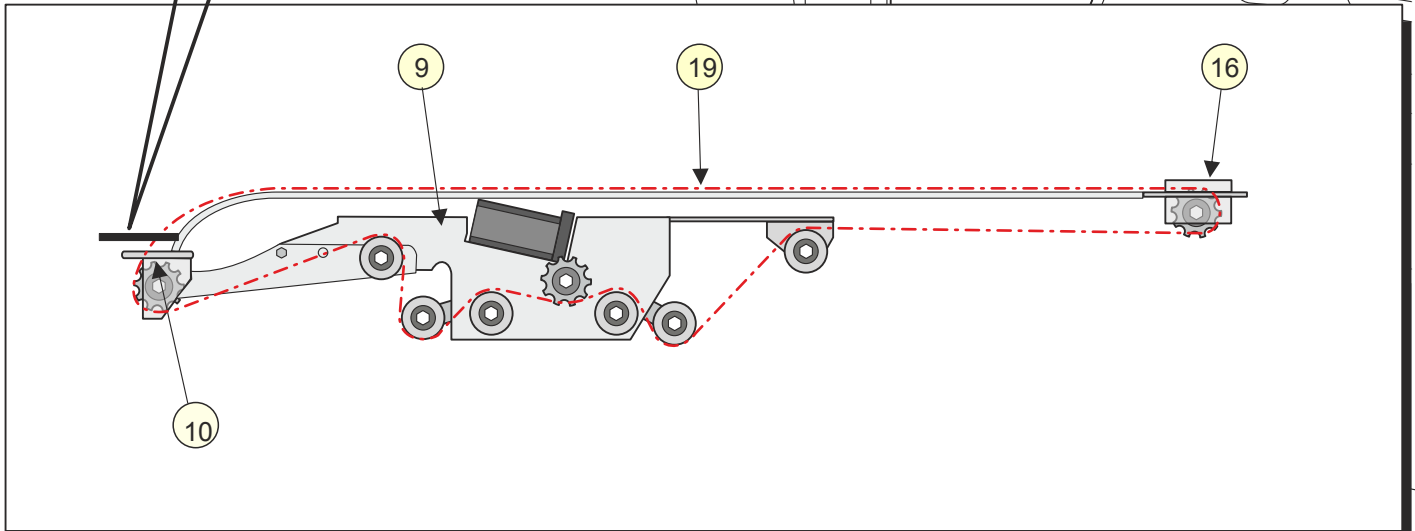
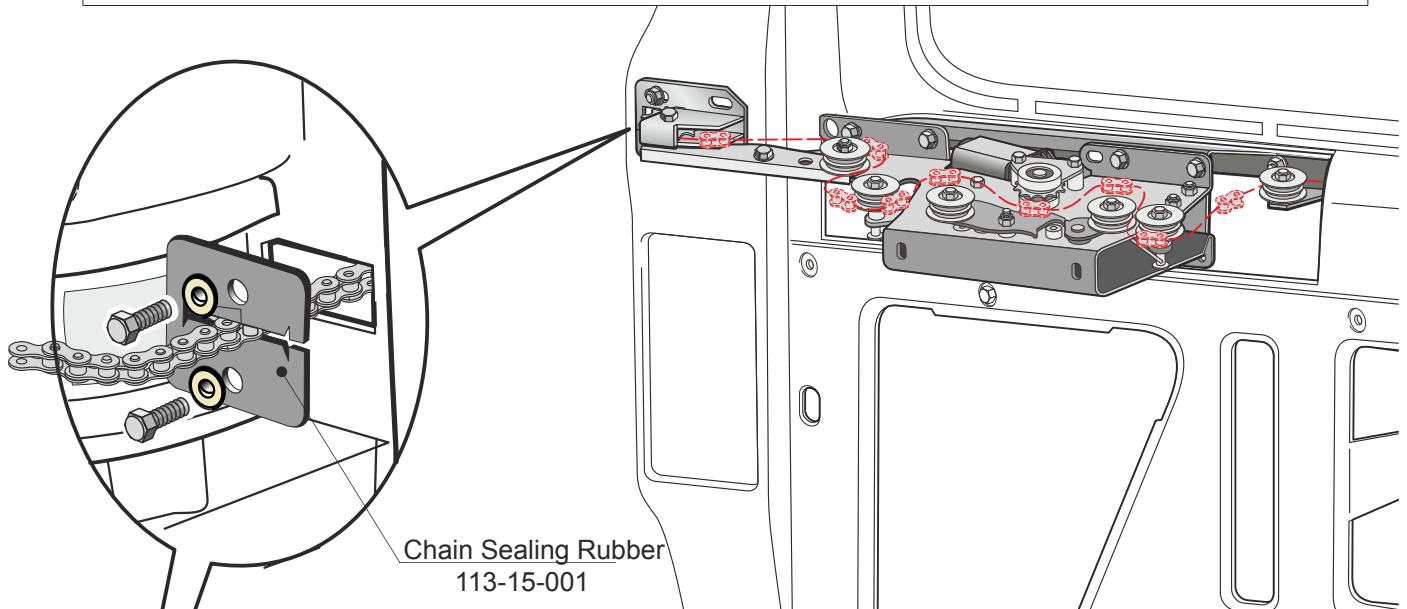
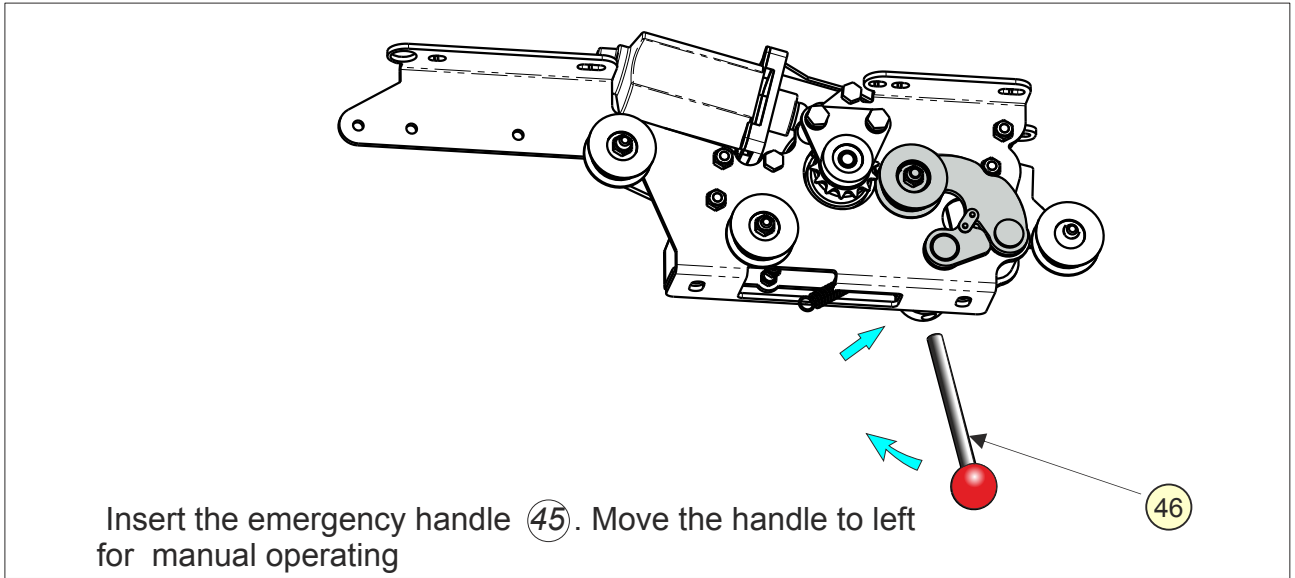


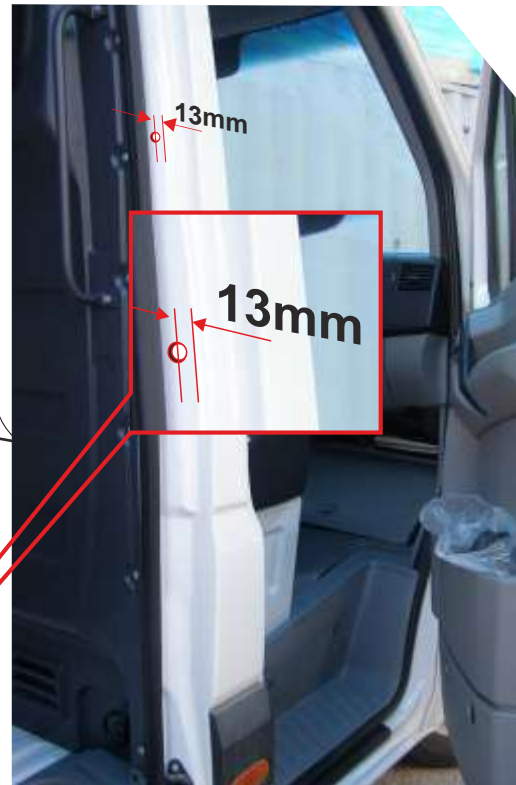
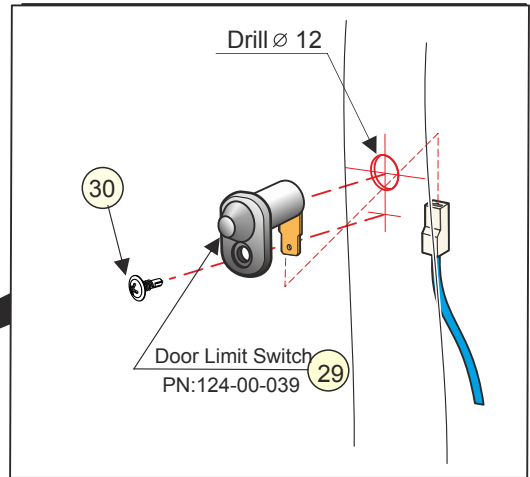
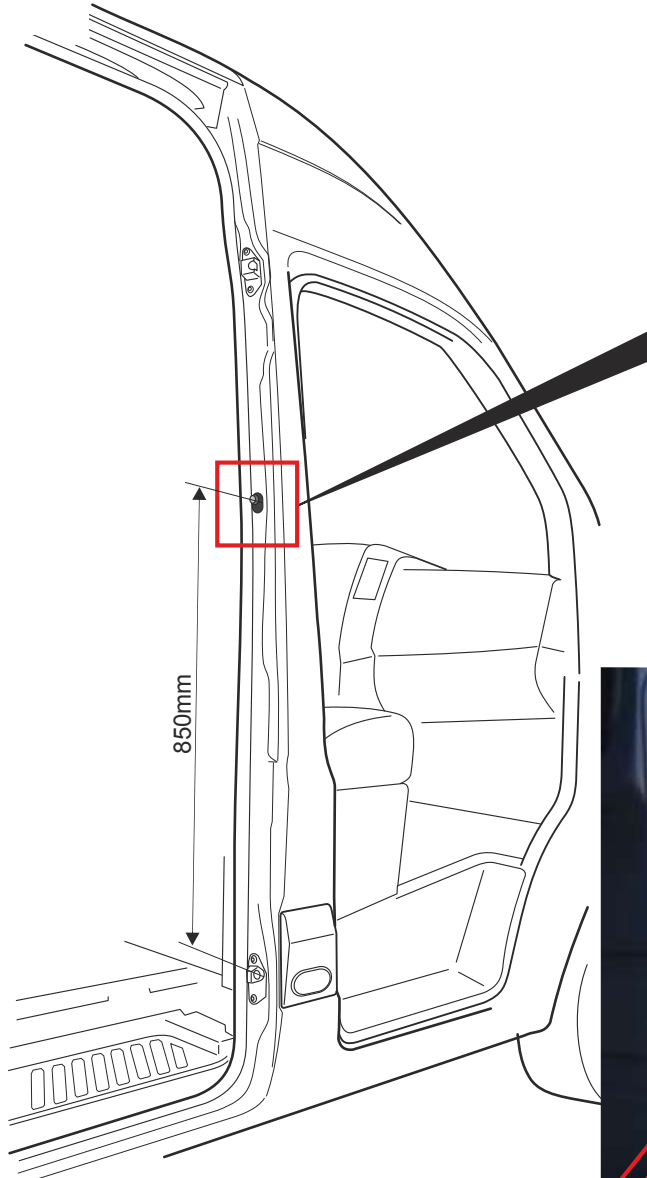
(196 standard)

- | | | |
|----|--|------------------------------------|
| 21 | | Socket button head screw M6X16 - 2 |
| 22 | | Lock nut M6 - 2 |

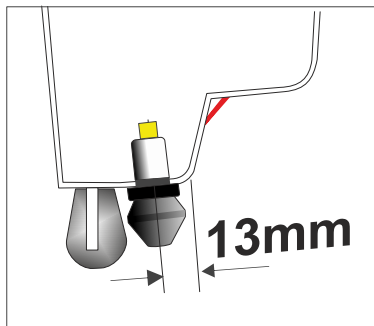
Do not separate the cart from the door
Drill the hole on the spot

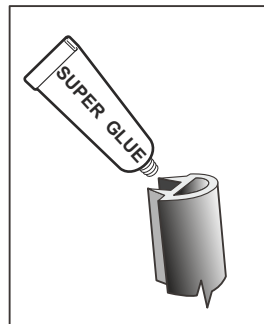
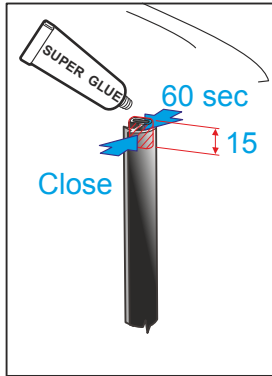
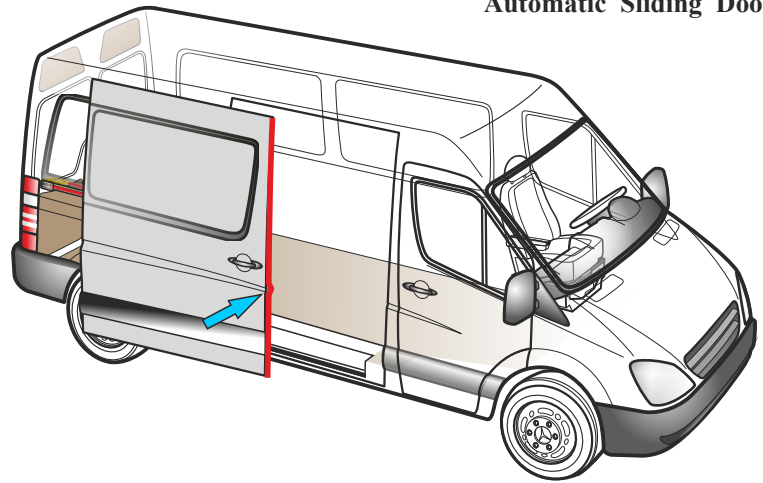




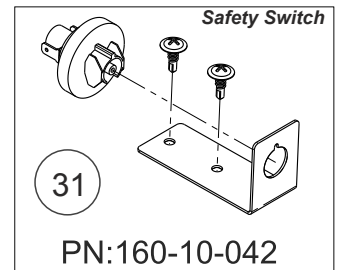


Pneumatic Switch Set
PN:160-10-042

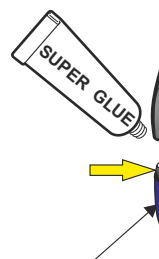
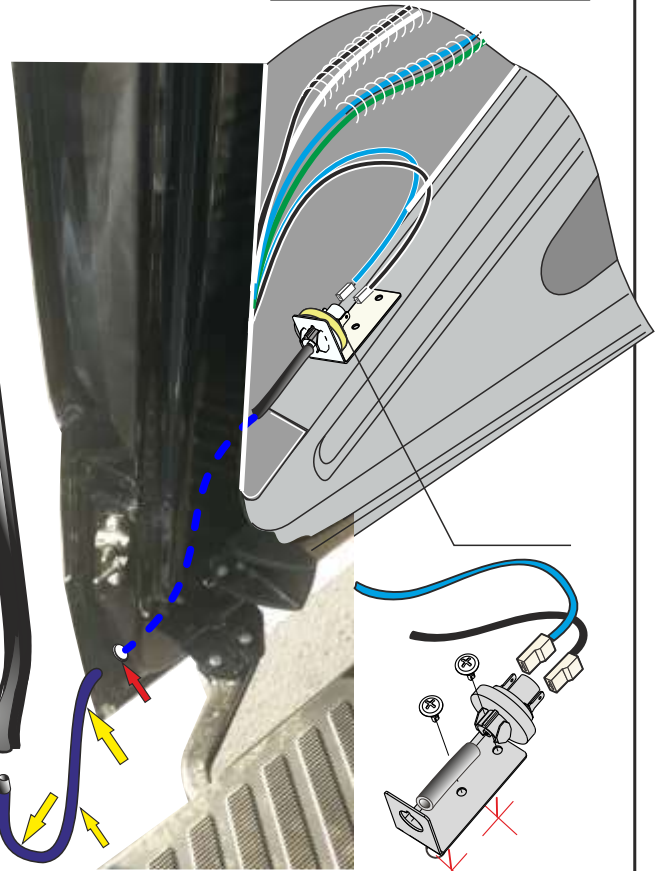




Clean surface carefully with alcohol to insure good contact of the pneumatic safety strip.

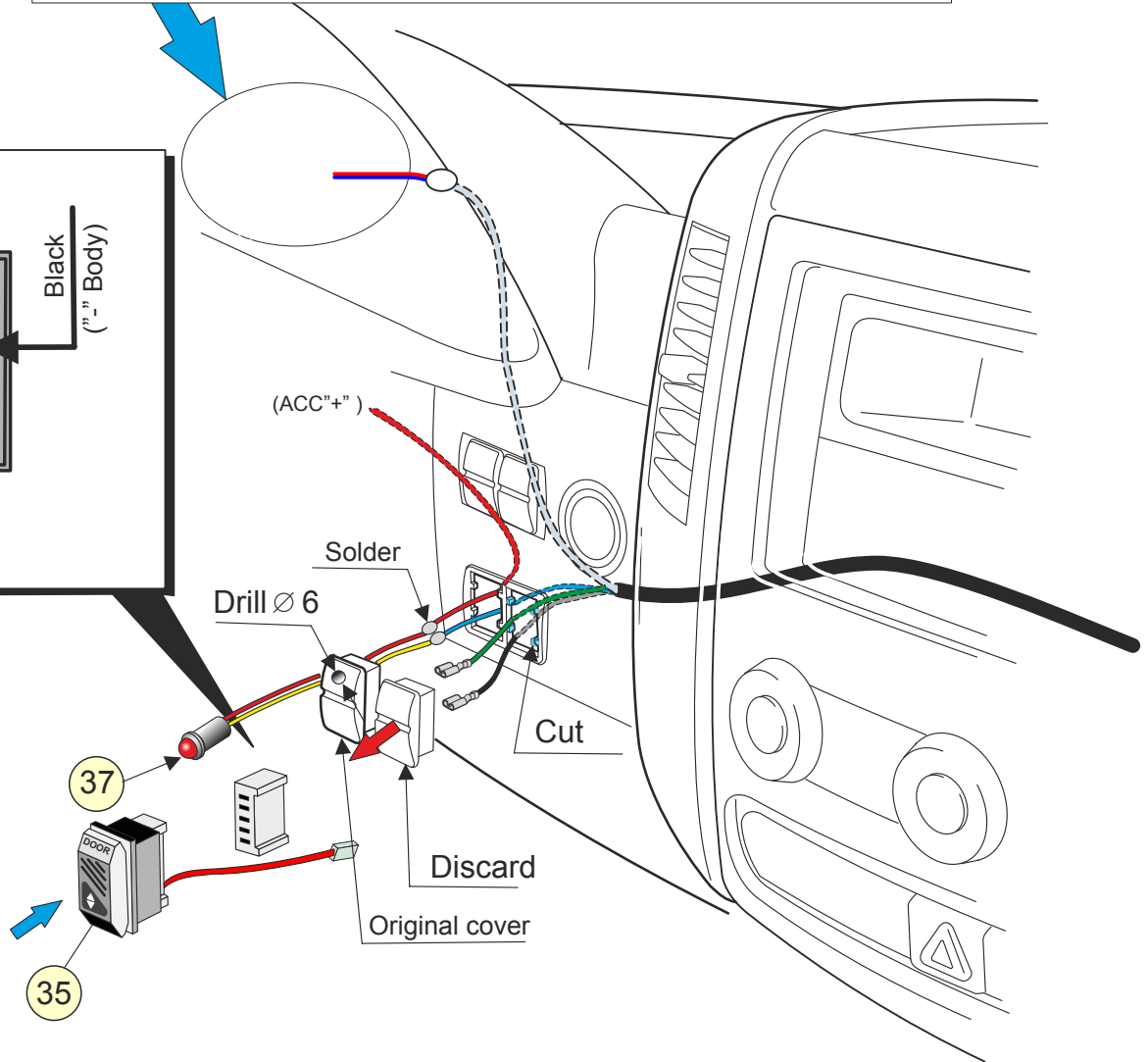
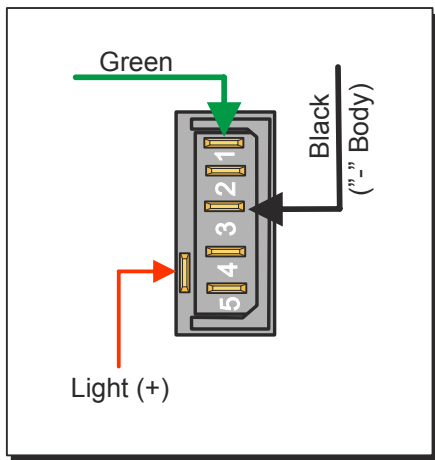
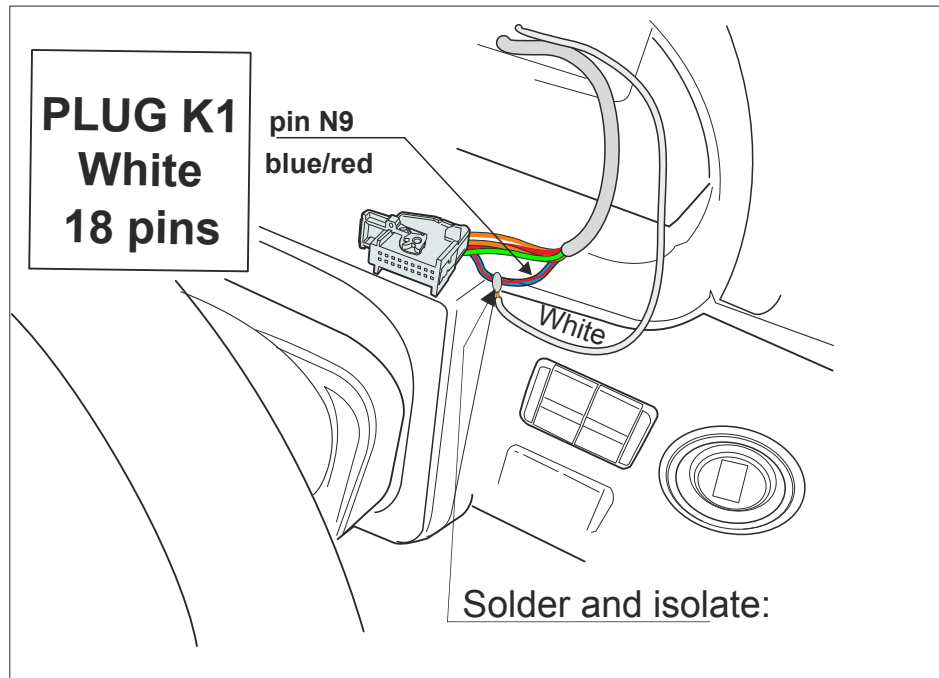


Pneumatic Safety Strip (33)
PN: 112-06-109



Rubber tube (34)

Drill hole for rubber tube

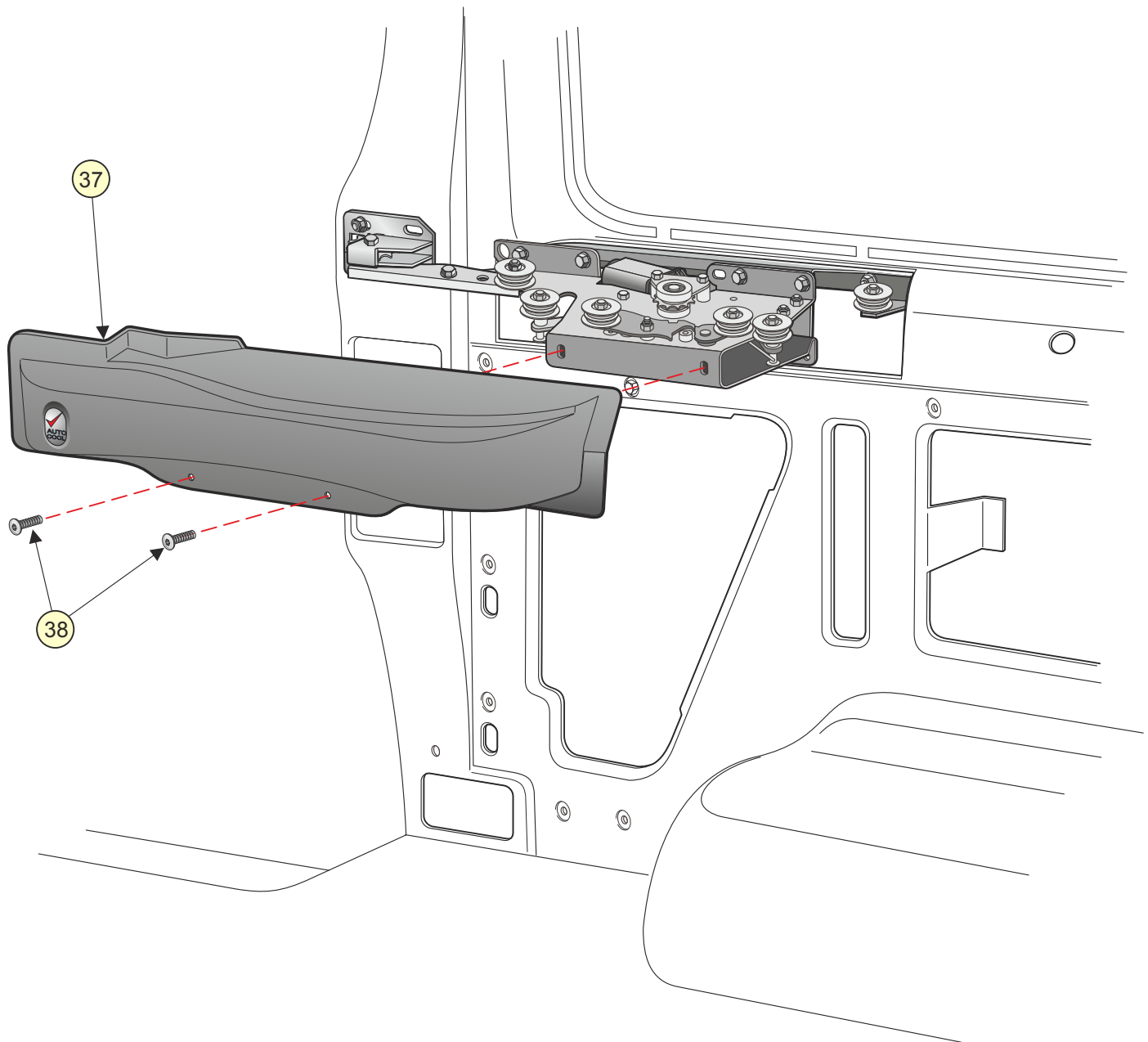
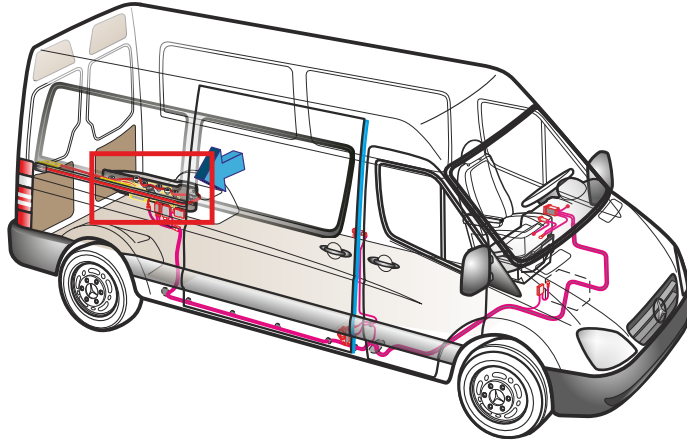




PLUG K1
White
18 pins

pin N9
blue/red



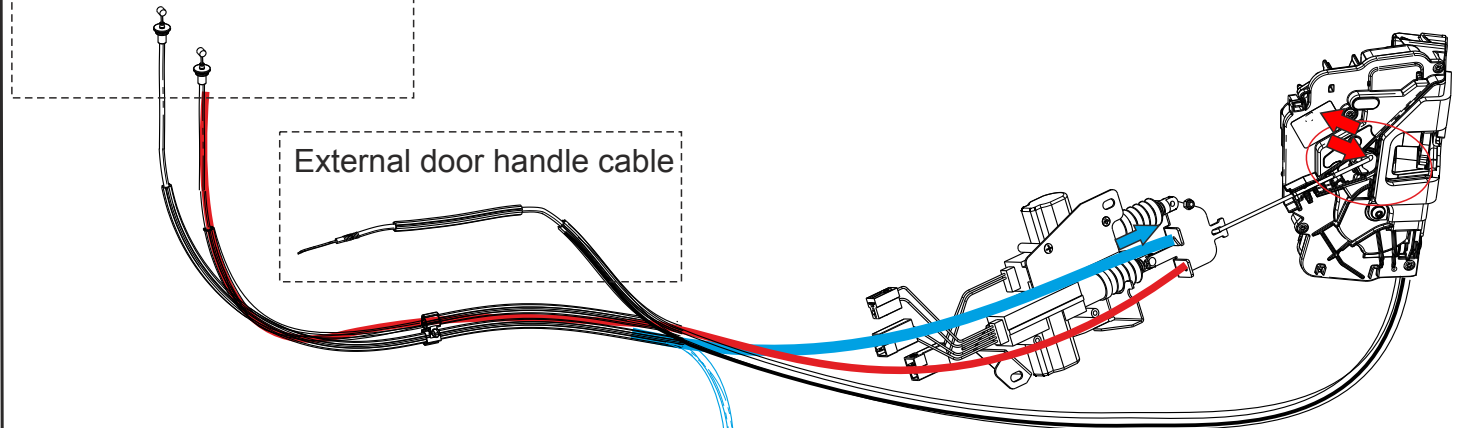


Parts list of ASD system

No	Designation	Part No	Quantity
1	Chain Slide strip	134-00-0081	1
2	Flat Head Screw M4X20	613-04-020	1
3	Lock Nut M4	602-02-004	1
4	Gear-Motor Support	111-00-0081	1
5	Thick Washer 6	600-32-061	4
6	Bolt M6X16	632-06-016	10
7	Washer 6	600-12-080	9
8	Hex flange nut M6	601-06-006	16
9	Gear-Motor ASSY	111-00-013	1
10	Front Idler	111-02-017	1
11	Front Idler Support	128-00-008C	1
12	Bolt M6X30	632-06-030	2
13	Idler Wheel	107-11-004-1	1
14	Nut M6	601-02-006	2
15	Lock Nut M6	602-02-006	3
16	Rear Idler	111-02-013	1
17	Socket button bolt M6x16	614-06-016	2
18	Chain Holder	128-00-008D or 128-15-030	1
19	Roller Chain	178-00-0081	1
20	Connecting link	900-01-072	3
21	Socket button bolt M5X16	614-05-016	1
22	Lock Nut M5	602-02-005	1
23	Cover	151-20-003	1
24	Philips Screw 8X5/8	646-08-058	4
25	Bolt M6X25	632-06-025	5
26	Nut Plastic Cover	112-10-002	1
27	Rear Idler Cover	151-10-003	1
28	Hex flange nut M8	601-08-008	2
29	Limit Door Switch	124-00-039	1
30	Self Drill Screw 8-1/2"	647-08-003	1
31	Pneumatic Safety Switch	122-10-047 (160-10-042)	1
32	Rubber Grommet #12	112-04-000	3
33	Pneumatic Safety Strip	112-06-109	2m
34	Rubber Tube	113-06-067	1
35	Operating Switch	124-00-026-1	1
36	Signal Light	124-10-069	1
37	Gear-Motor Cover	153-00-0081	1
38	Flat Head Screw M6X20	632-06-020-1	2
39	Emergency Handle	128-05-012	1

Internal door handle cables

External door handle cable



Lower release cable



Cancel the lower latch



Figure 1. Remove original step



Figure 2.



Figure 3.



Figure 4.

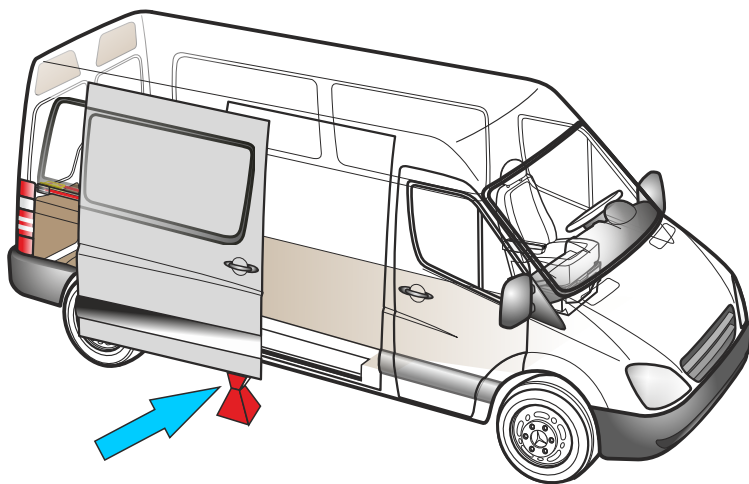


Figure 5.



Make marks position lower roller ASSY screws before disassembling

Figure 6.



Figure 1.



Disconnect the cable and move him to a new location

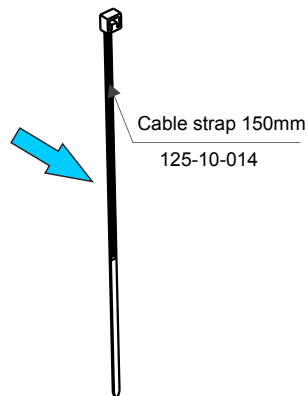
Figure 2.



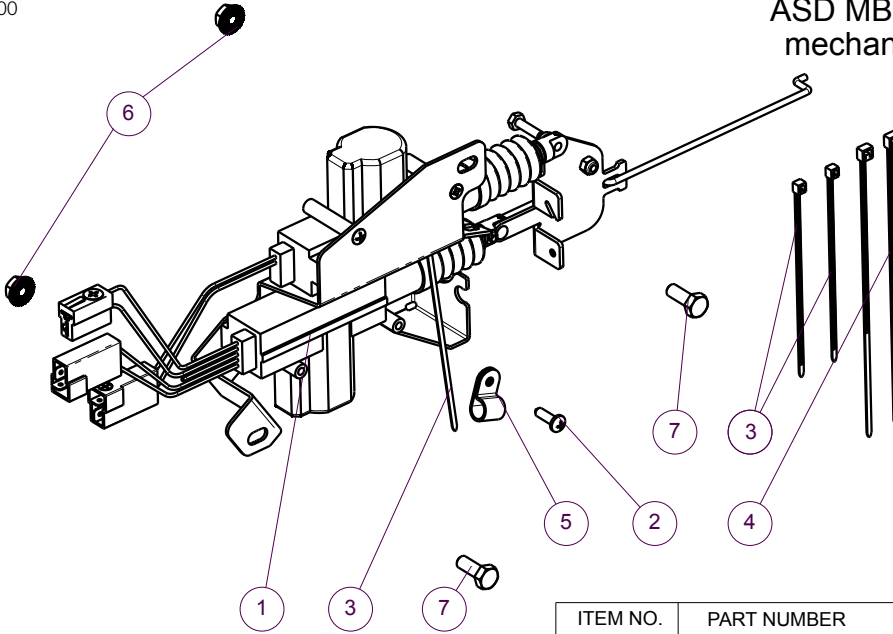
Figure 3.



Figure 4. Cancel the lower latch

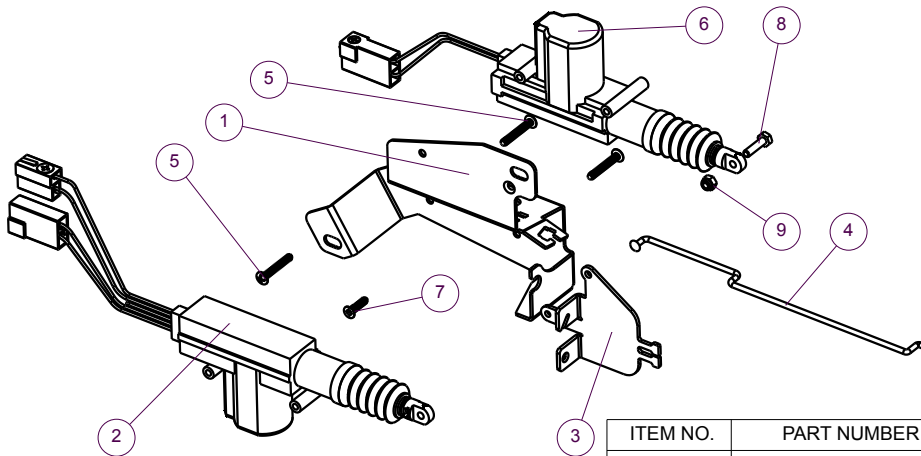


ASD MB Sprinter Original Door latches mechanism & operation with handles
160-15-301



ITEM NO.	PART NUMBER	DESCRIPTION	QTY.
1	111-15-301	MB Sprinter locker bracket ASSY	1
2	646-08-020	Phillips screw 6x3/8"	1
3	125-10-016	Cable strap 100mm	3
4	125-10-014	Cable strap 150mm	2
5	125-10-005	Plastic clamp UC-2 3/8"	1
6	601-06-006	Hex flange nut M6 DIN 6923	2
7	632-06-016	Hex cap screw M6x15	2

MB Sprinter lockers ASSY
111-15-301



ITEM NO.	PART NUMBER	DESCRIPTION	QTY.
1	128-15-301	Actuator bracket	1
2	110-01-006-10	Lock actuator ASSY	1
3	128-15-203	Cables adapter	1
4	128-36-309	V363: V408 Lock Actuator arm	1
5	Phillips cross Screw 4.2		3
6	110-11-006	Actuator ASSY	1
7	647-11-046	Phillips cross screw 4-5/8"	1
8	632-04-016	Hex bolt M4x16 , DIN933	1
9	602-02-004	Lock nut M4 DIN985	1



Pull off door latch mechanism
Figure 1.



Disconnect inner door handle cable
Figure 2.



Connect inner door handle cable
to the new position
Figure 3.



Drill 6.5 mm two holes
Figure 4.



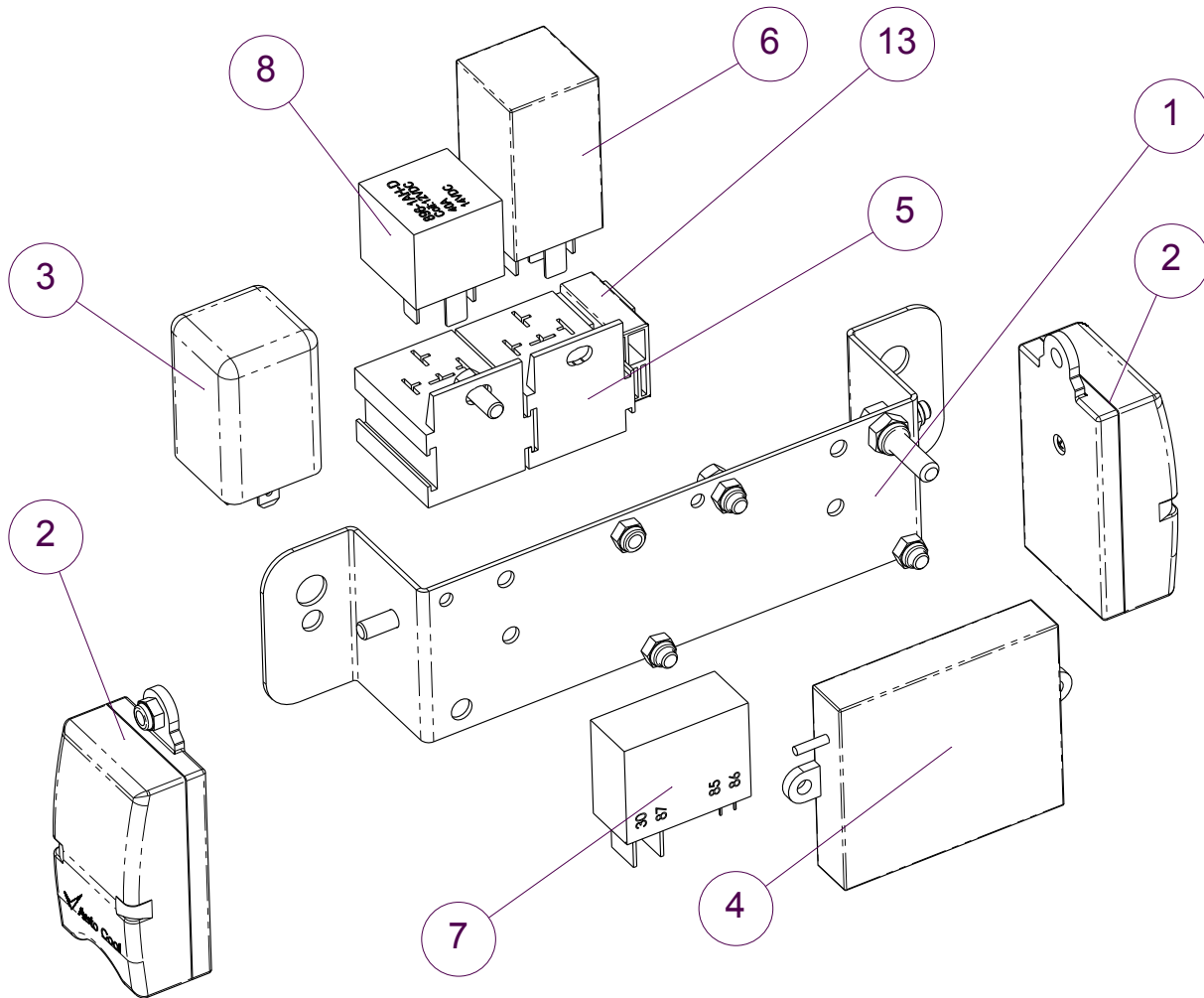
Figure 5.



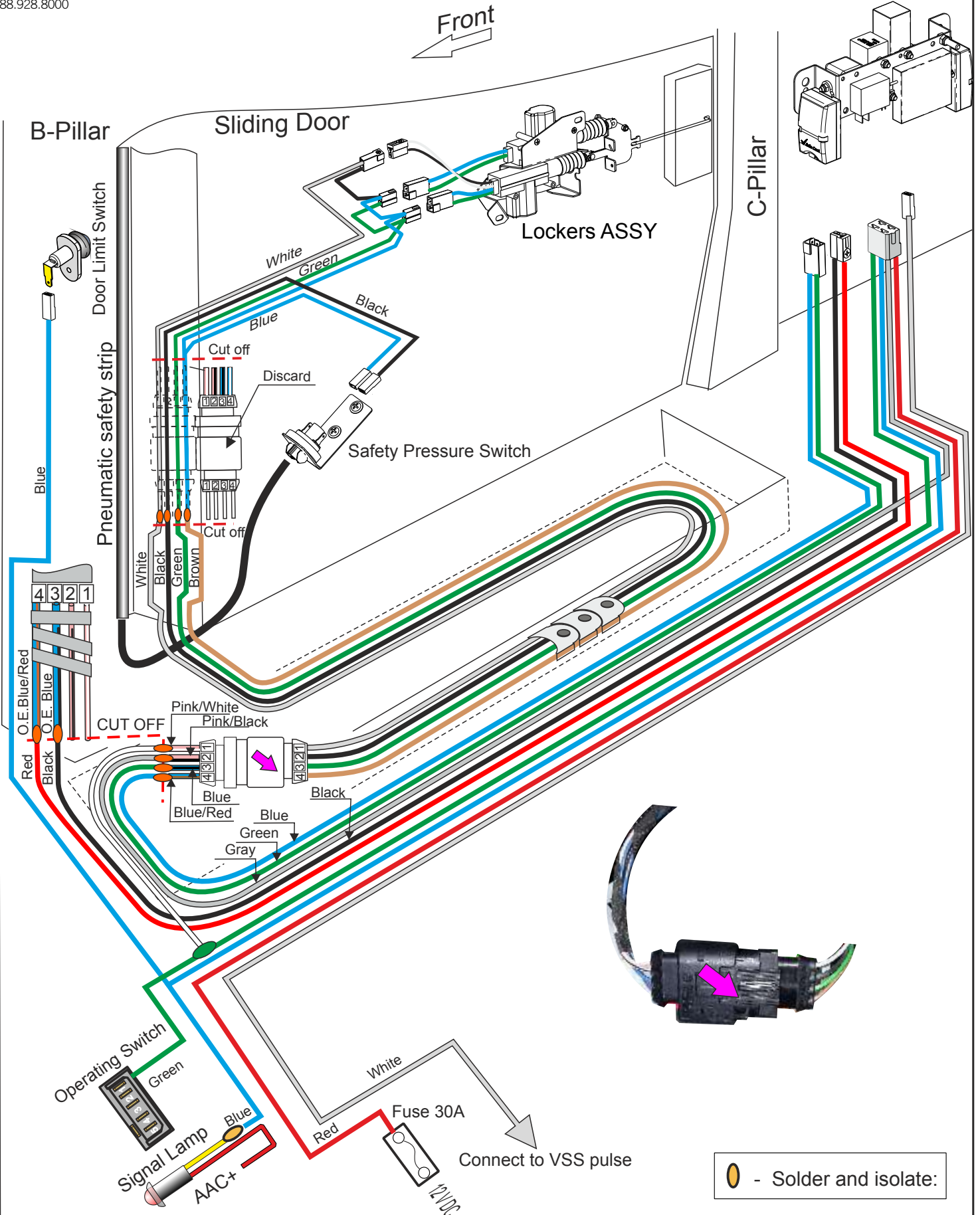
Figure 6.

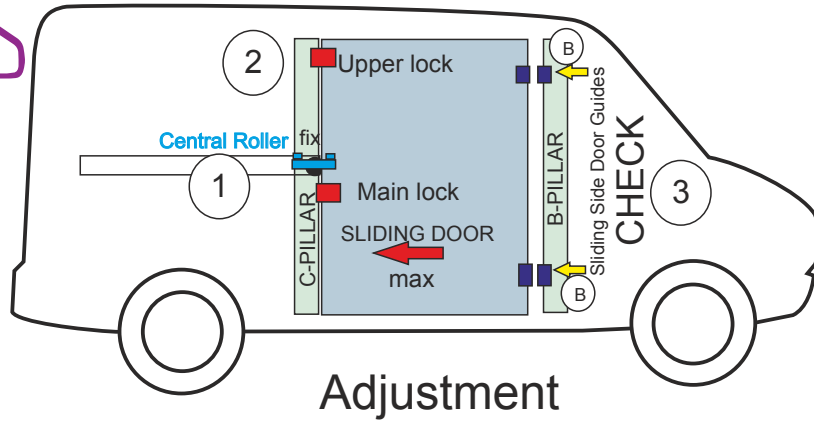


Figure 7.



ITEM NO.	PART NUMBER	DESCRIPTION	QTY.
1	128-17-116	Bracket	1
2	A-K-101	Control module	3
3	124-00-032		2
4	124-02-006		1
5	124-10-052	CONNECTOR	2
6	123-06-004		1
7	124-12-902	Latch RelayDS12V -60A 250VAC	1
8	124-R2A4		1

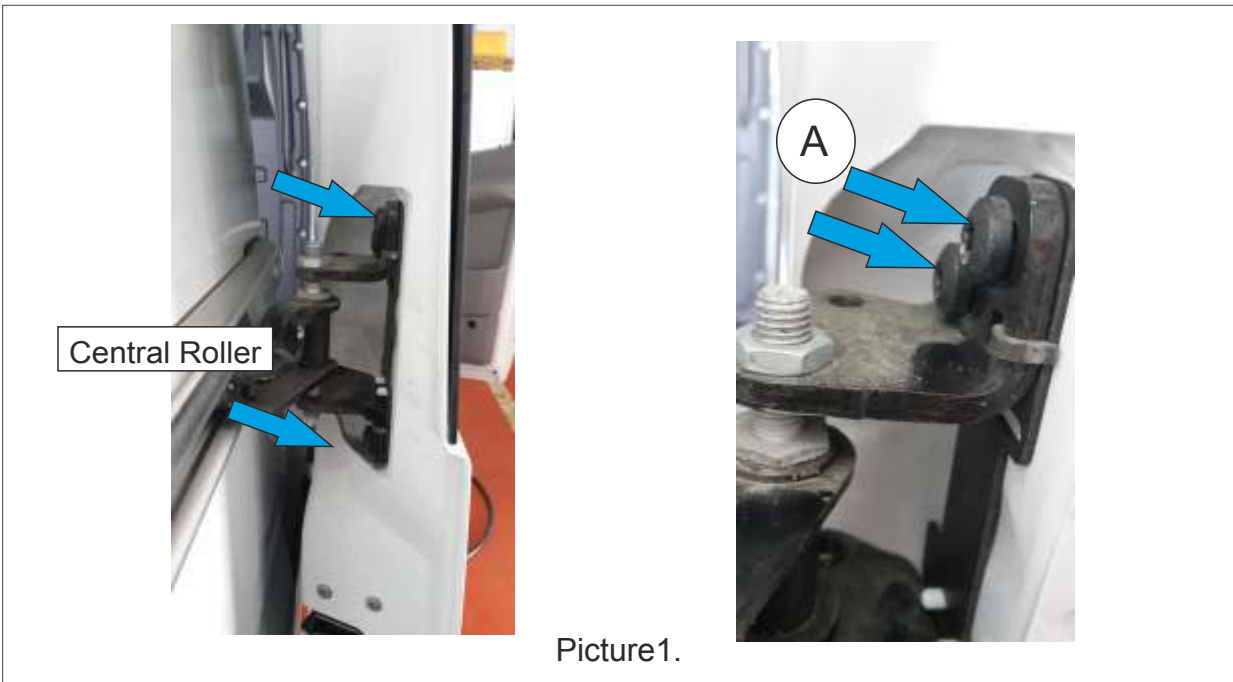




Adjustment

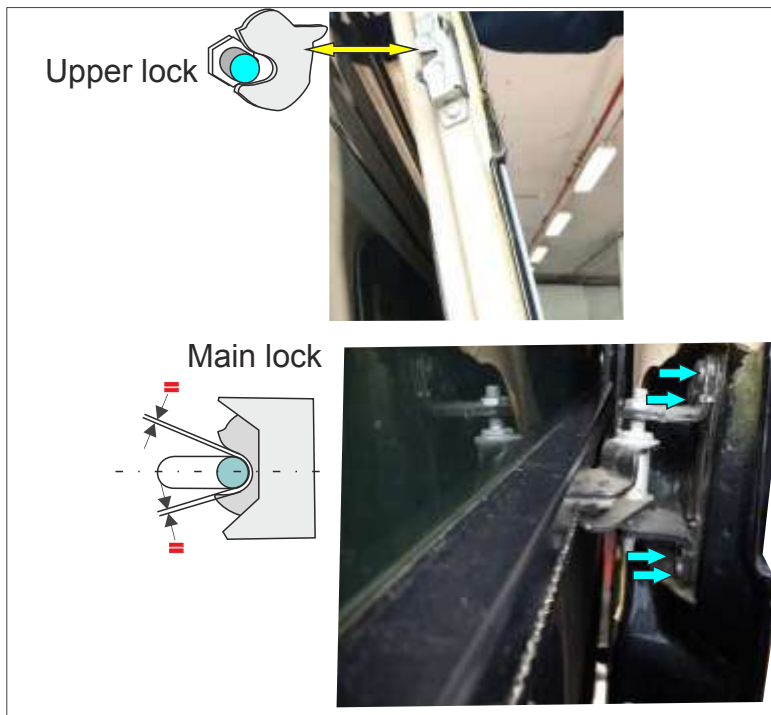
1. Adjust the sliding door.

- a. Loosen the 4 screws. see Picture 1.
- b. Move the door max c-pillar direction, relatively to the central roller.

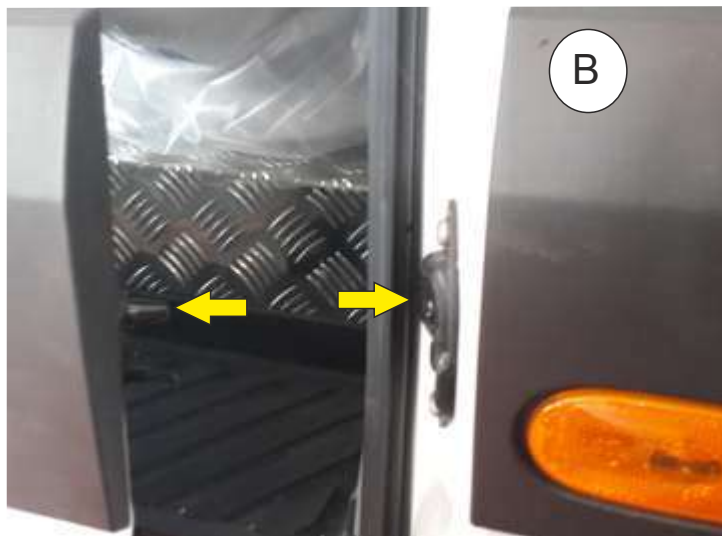


Picture1.

2. Check Main lock and Upper lock



3. Adjust the sliding door guides (parts on the sliding door). See pictures. (B)

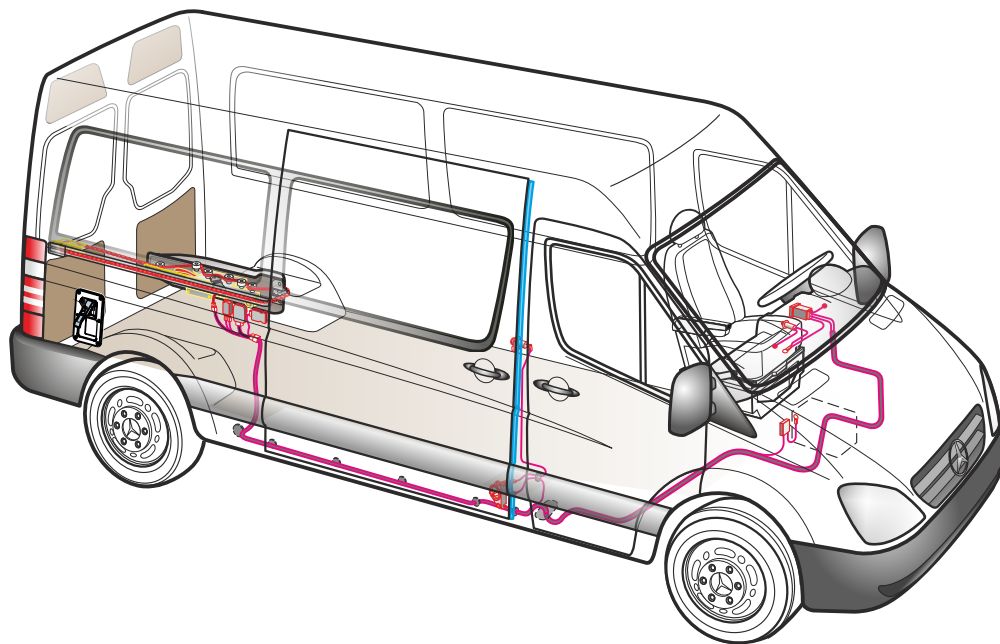


Power Door & Step



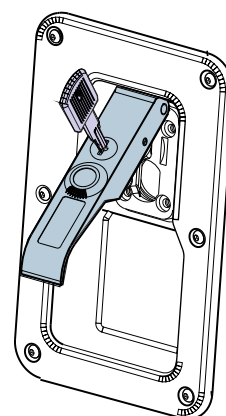
PowerDoorAndStep.com

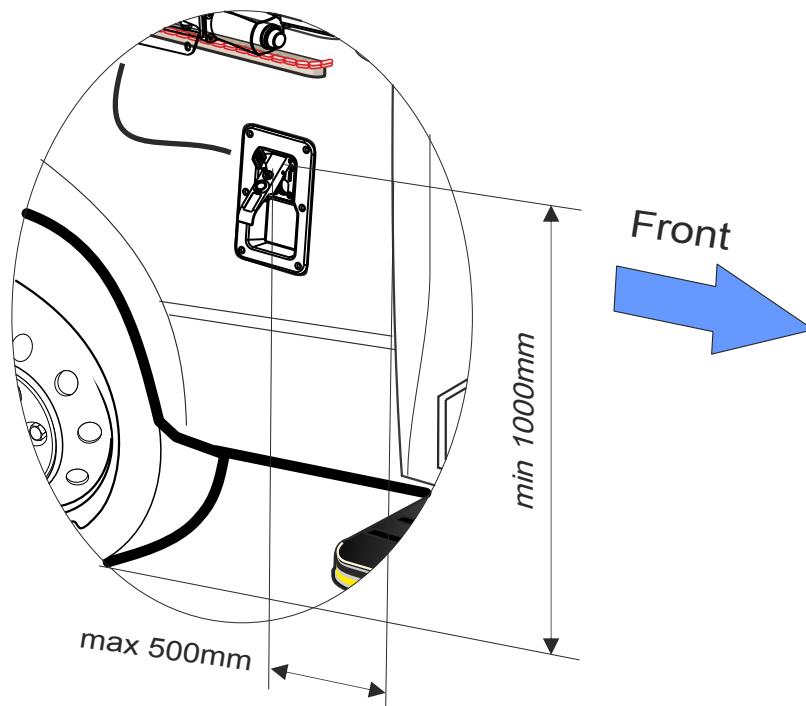
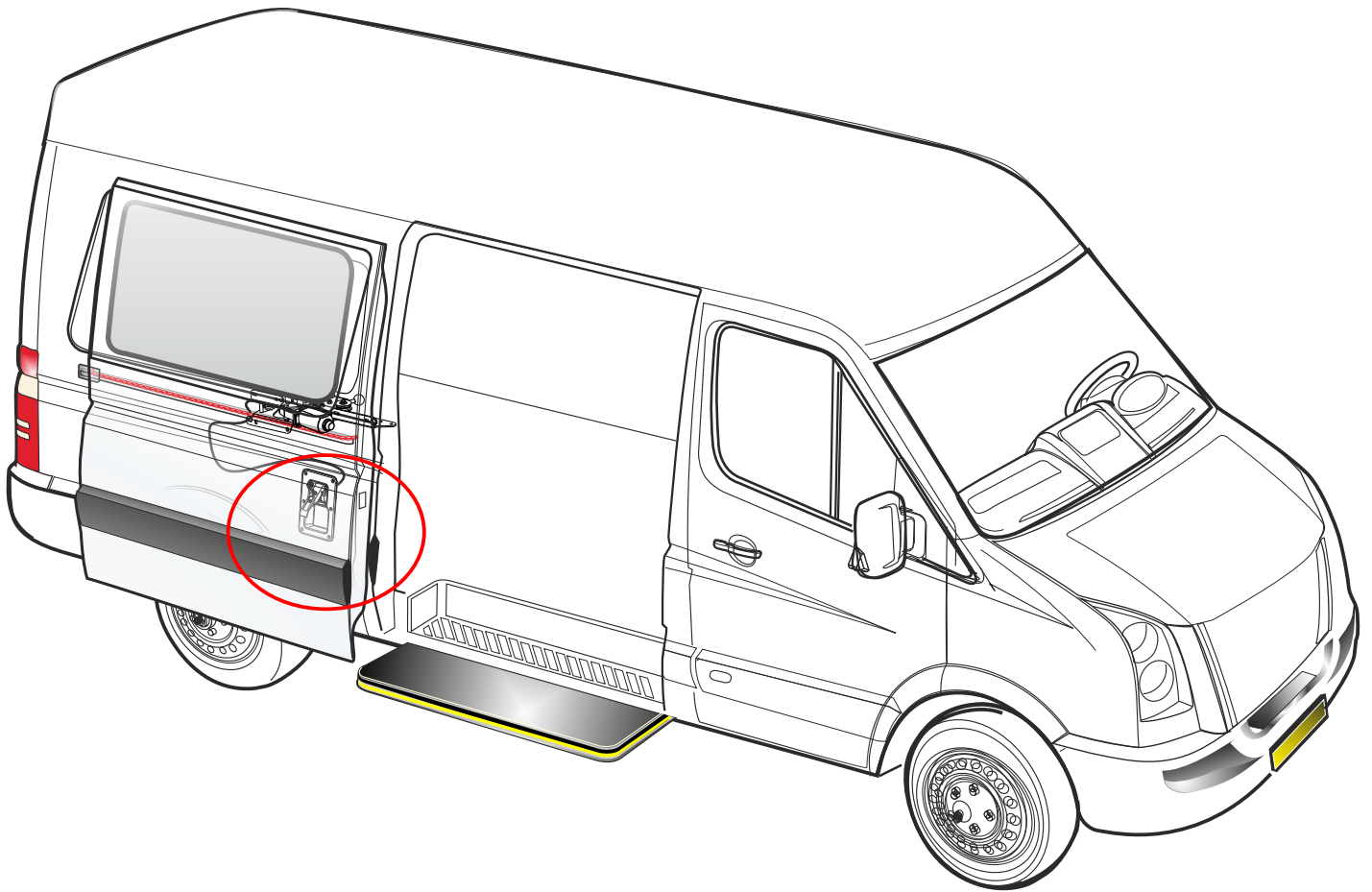
888.928.8000



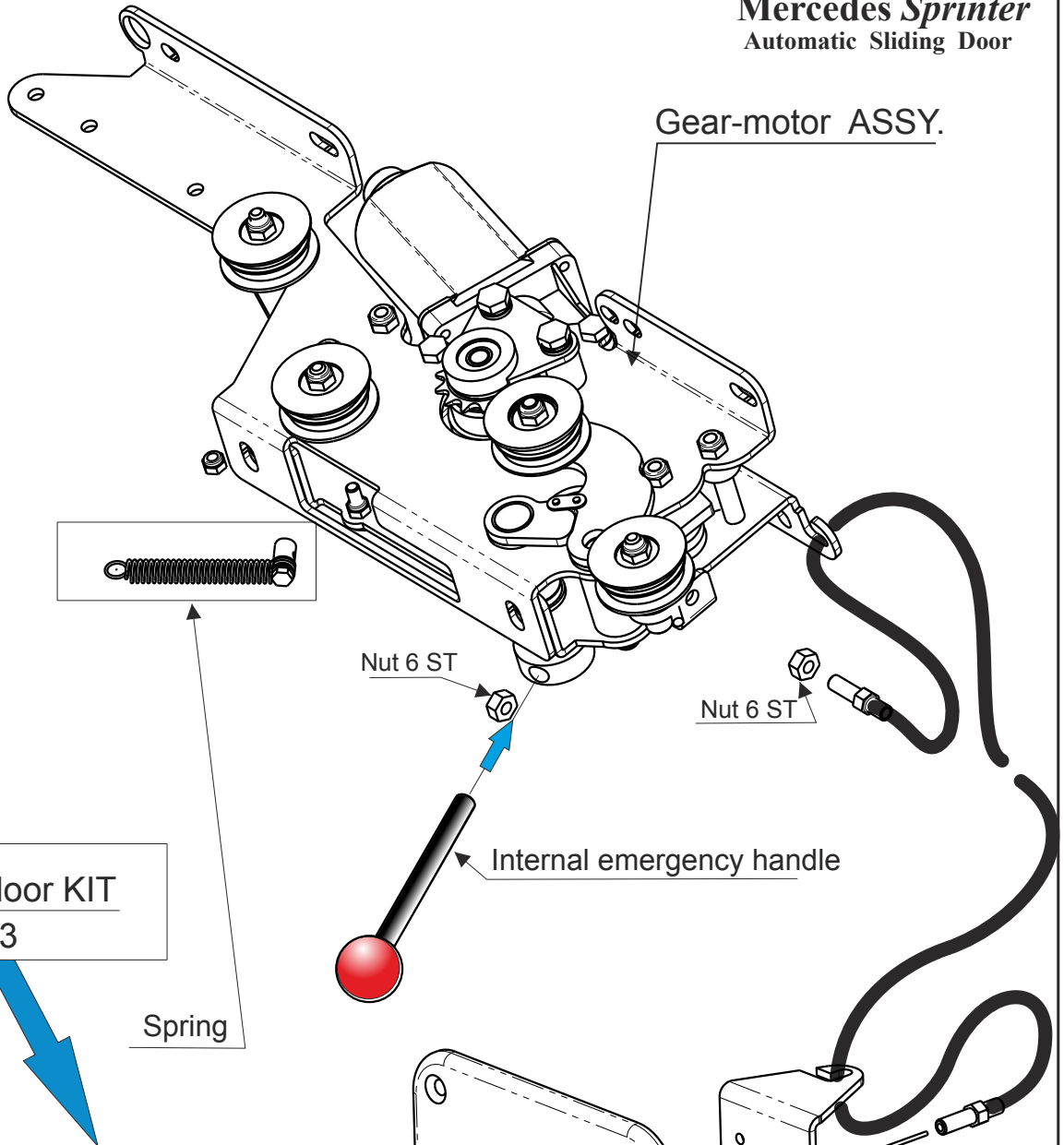
ASD Automatic Sliding Door Emergency door opening kit

PN: 111-03-013





Gear-motor ASSY.



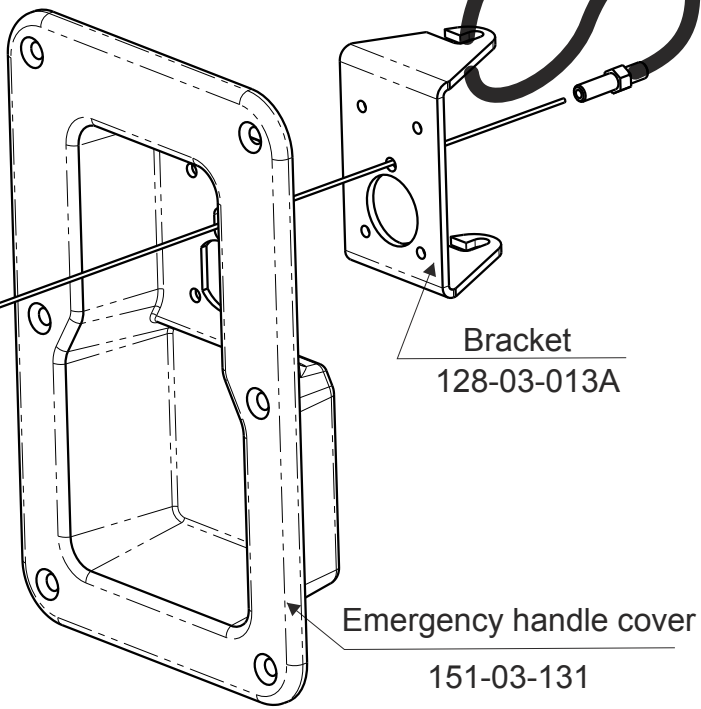
Emergency door KIT
 111-03-013

Spring

Nut 6 ST

Nut 6 ST

Internal emergency handle



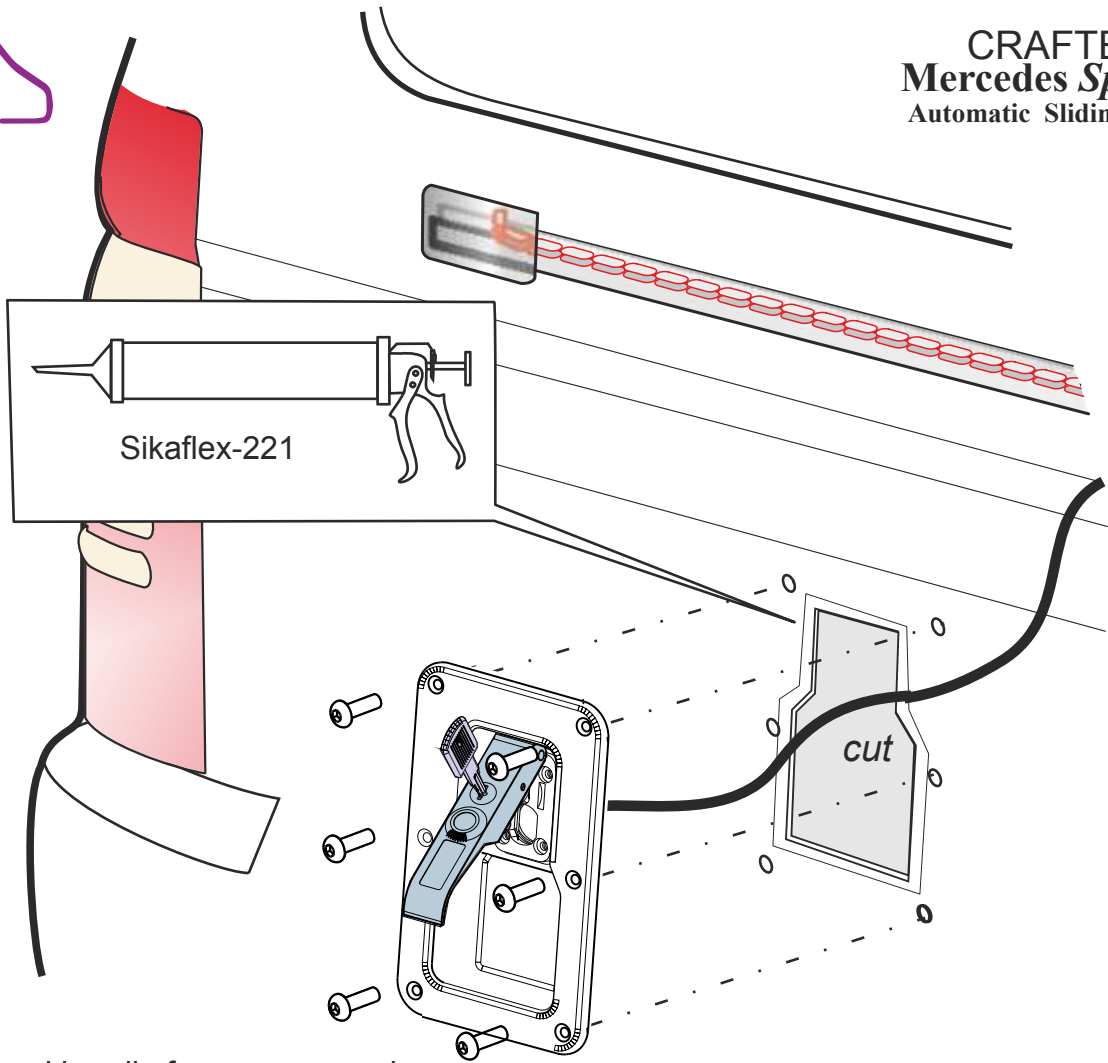
Bracket
 128-03-013A

Emergency door handle
 111-03-0131

Emergency handle cover
 151-03-131

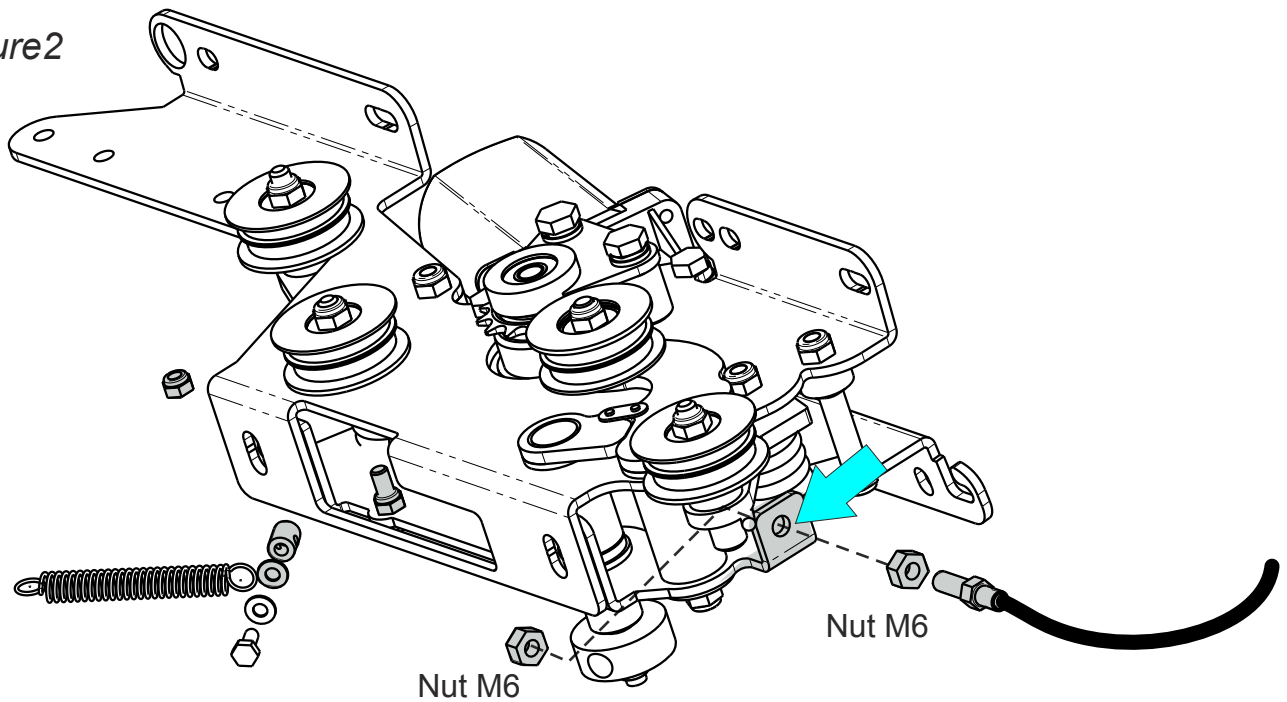
Socket head M5X16

Figure 1

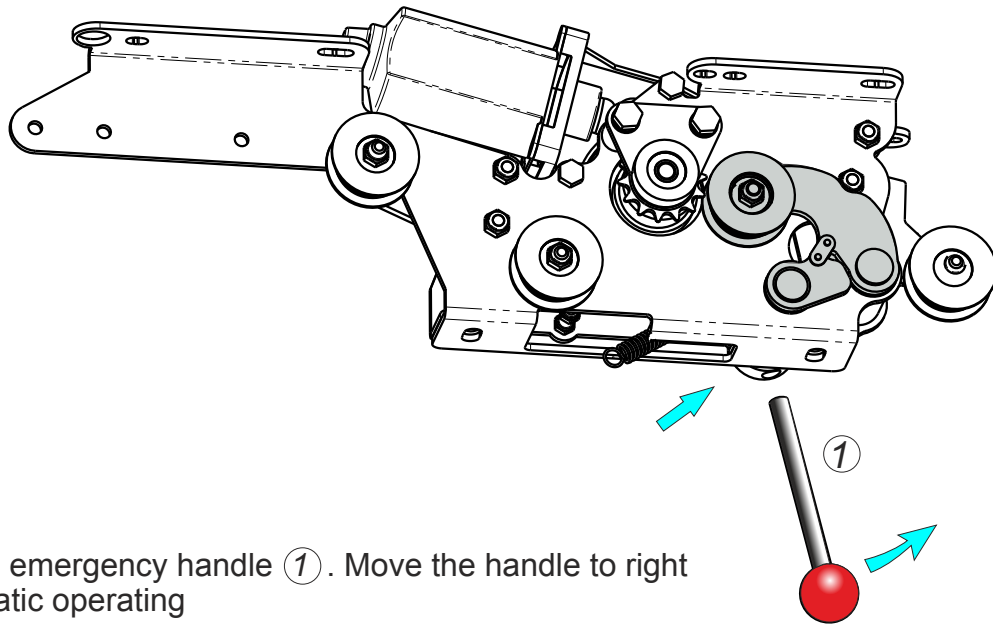
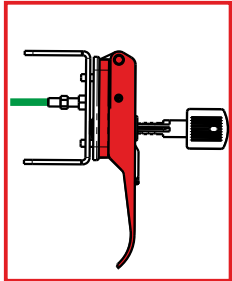


Install the external handle for emergency door

Figure 2

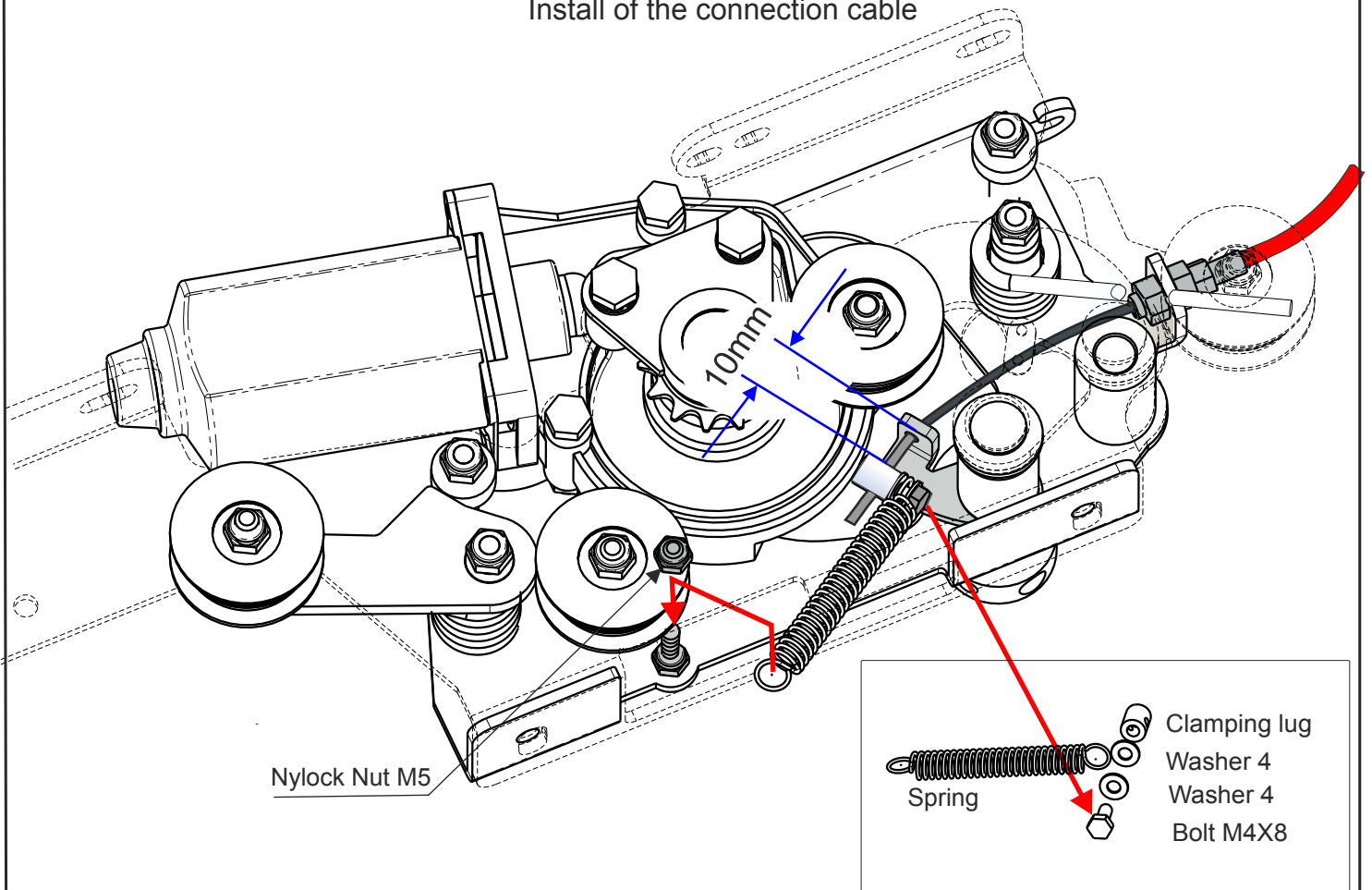


To install the cable:
Insert the cable into the hole (see figure 2) fasten nuts M6



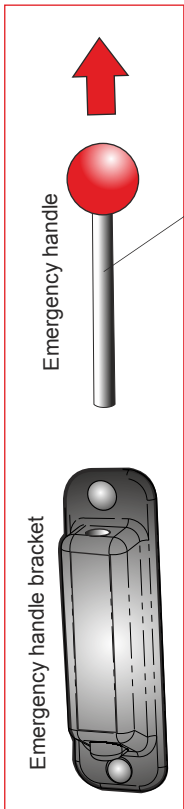
Insert the emergency handle ①. Move the handle to right for automatic operating

Install of the connection cable

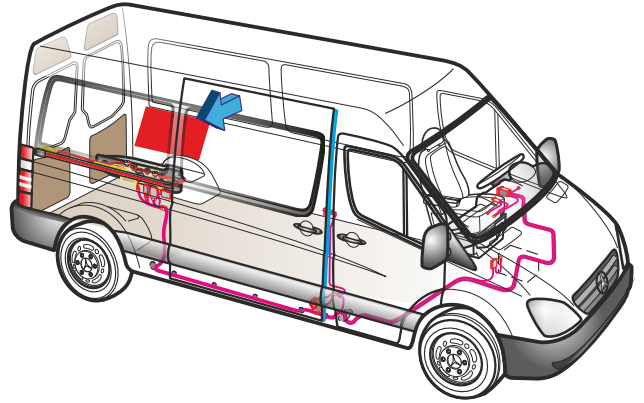
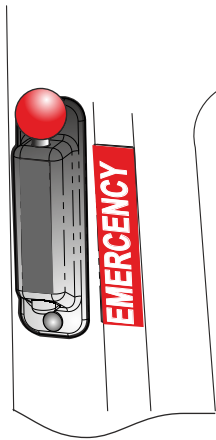


Nylock Nut M5

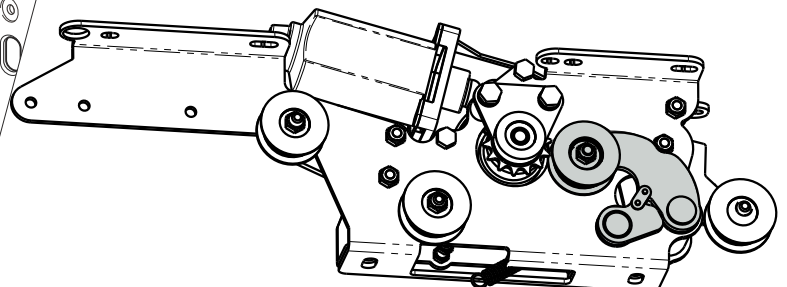
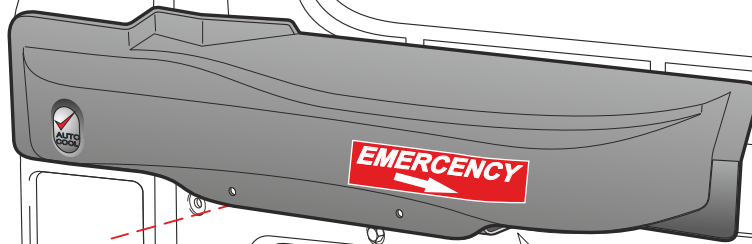
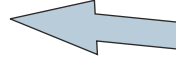
- Clamping lug
 - Washer 4
 - Washer 4
 - Bolt M4X8
- Spring



39



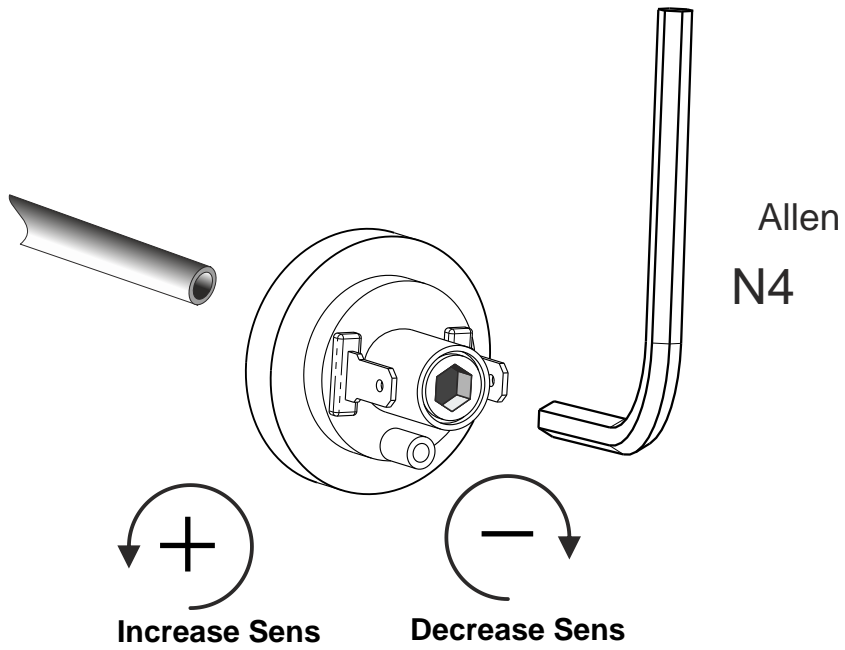
FRONT



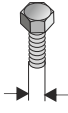

Insert the emergency handle ①. Move the handle to left for manual operating

EMERGENCY OPENING

**Pressure Safety Switch
Sensitivity adjustment**



RECOMMENDED TORQUE FIGURES
(In newton metres)

 8.8	TORQUE Nm	 mm	TORQUE Nm
M5	6.3	M5	8
M6	10.3	M6	10
M8	25.4	M8	13

Automatic Sliding Door user's Manual

The Automatic Sliding Door system (ASD) manufactured by Auto Cool Ltd conforms with the requirements of the European regulations.

The ASD is approved by the German TUV in Munich, it complies with the **EEC DIRECTIVE 72/245EC and obtained the certificate of compliance No 2004/104/EC.**

Operation Instructions

- The door is operated by a switch located on the dashboard:
- **To open**—press the switch shortly, door opens to the end of its range.
- **To close** - press the switch shortly, door closes and locks.
- **To change its direction while in motion** - press the switch shortly, the door will change direction.
- **To control the opening range** – continuous pressure on the control switch will set the door in motion upon its release, the door will stop.
- **Visual status indications** – when the vehicle's main ignition switch is “on”, the indication control light is visible.
- Dim light – the door is closed.
- Bright light – the door is open.
- **Audio status indicators** – **independently of the vehicle's main switch** – the vehicle's buzzer is always functioning whenever the door is in closing motion.

Safety measures

The system includes **safety features** to protect the passengers.

- **Closing** – when encountering an obstruction, the controller automatically reverses the door direction to open all the way .
- In addition, a pneumatic switch is attached to the front side of door pillar, which upon sensing pressure performs the same function and retracts immediately.
- **Opening** - when encountering an obstruction, the controller stops the door.
- ASD system is connected to the OE VSS device. The door operates only at speed of less than 5 km/h.

Emergency facility

The system has inside and outside (optional) emergency releasing handle. Operating one of them will result in disconnecting the ASD mechanism device and the door will function manually immediately.

Please note:

The system performs automatic reset after the ASD has been disconnected from the power either when replacing the fuse or by disconnecting the Battery.

The system resets itself within two minutes. Please be patient.

ASD: Basic Troubleshooting

1. Door does not function.
 - Check main fuse.
 - Check connections of power terminals to the control unit, motor and operating switch.
 - Check Control units AK-105L
 - Check motor.
2. Door does not operate upon commencing the closing mode or when reaching the fully closed positions it reverses.
 - Check the safety pneumatic pressure tube; disconnect the plugs of pressure switch and close the door.
 - If the issue is not solved, try to regulate the sensitivity of the pressure switch.
 - Check safety switch.
 - Reset the system by extracting the fuse and returning it to its place.
 - Check control unit – AK105.
3. Door does not close completely.
 - Check voltage of battery, if low, start the engine.
4. Door does not open, although the electrical motor is engaged.
 - Check position of the locker unit, which annuls the OEM locking system of the door.
5. Door does not automatically reverse when encountering an obstruction during the closing mode.
 - Check safety pneumatic switch.
 - Check pressure tube & switch.
 - Check control unit.
6. Noise from the door's chain during opening and or closing modes.
 - Check installation and alignment of all wheel supports, front and rear, as well as the gear motor support.
 - Very loose chain may also jump over and cause damage to the sprocket's main motor.
 - Check chain tension and if needed shorten it by removing one or two "links".
7. Remote control unit does not function.
 - Check connection of power terminals.
 - Check battery of the key unit transmitter.

It issue still persist replace remote control receiver with two transmitters
8. If equipped with VSS, the door operates although the vehicle is in motion over 5Km/h.
 - Check connections to the VSS unit.
 - Check VSS unit.
9. Buzzer does not operate during the closing mode.
 - Check buzzer or replace it.

Please note:

The system performs automatic reset after the ASD has been disconnected from the power either when replacing the fuse or by disconnecting the Battery.
The system resets itself within two minutes. Please be patient.