



RPM Rivian Running Boards Installation Manual for R1T & R1S



Please watch our DIY Video before installing



Important Information

- 1. WARNING:** Read this document before using the RPM Rivian Running Boards.
2. This is intended only to be used with Rivian R1T & R1S vehicles. Do not use it for any other purpose.
3. The installation instructions may be slightly different from the actual operation. If there is any difference, please watch our installation video.
4. Make sure the brackets are installed correctly in each direction. Contact our customer support for any repairs at rpmrivian@gmail.com.
5. Do not clean with detergent or cleaning solvents.
6. Do not use if it is damaged in any way. Inspect before each use.
7. Please tighten the screws of each part to make the installation firm.

Product Parameter

Load-bearing	550lbs (250kg)
Running Board Dimensions	82.67in x 6.69in
Packing List	2 Running Boards + 6 Brackets
Installation Time	1 Hour
Material	High-Quality Carbon Steel
Design Style	Original Style
Certification	CE, FCC

NO.	NAME	QTY
1	Driver/ Left Running Board	1
2	Passenger/ Right Running Board	1
3	Driver/Left Front Mounting Bracket	1
4	Passenger/ Right Front Mounting Bracket	1
5	Driver/Left Middle Mounting Bracket	1
6	Passenger/ Right Middle Mounting Bracket	1
7	Driver/Left Rear Mounting Bracket	1
8	Passenger/ Right Rear Mounting Bracket	1
9	M8 x 30mm Hex Head Bolts	12
10	8mm Flat Washers	12
11	8mm Locking Washers	12

Installation Steps

1. Take out all parts from the box and verify that all parts are complete.

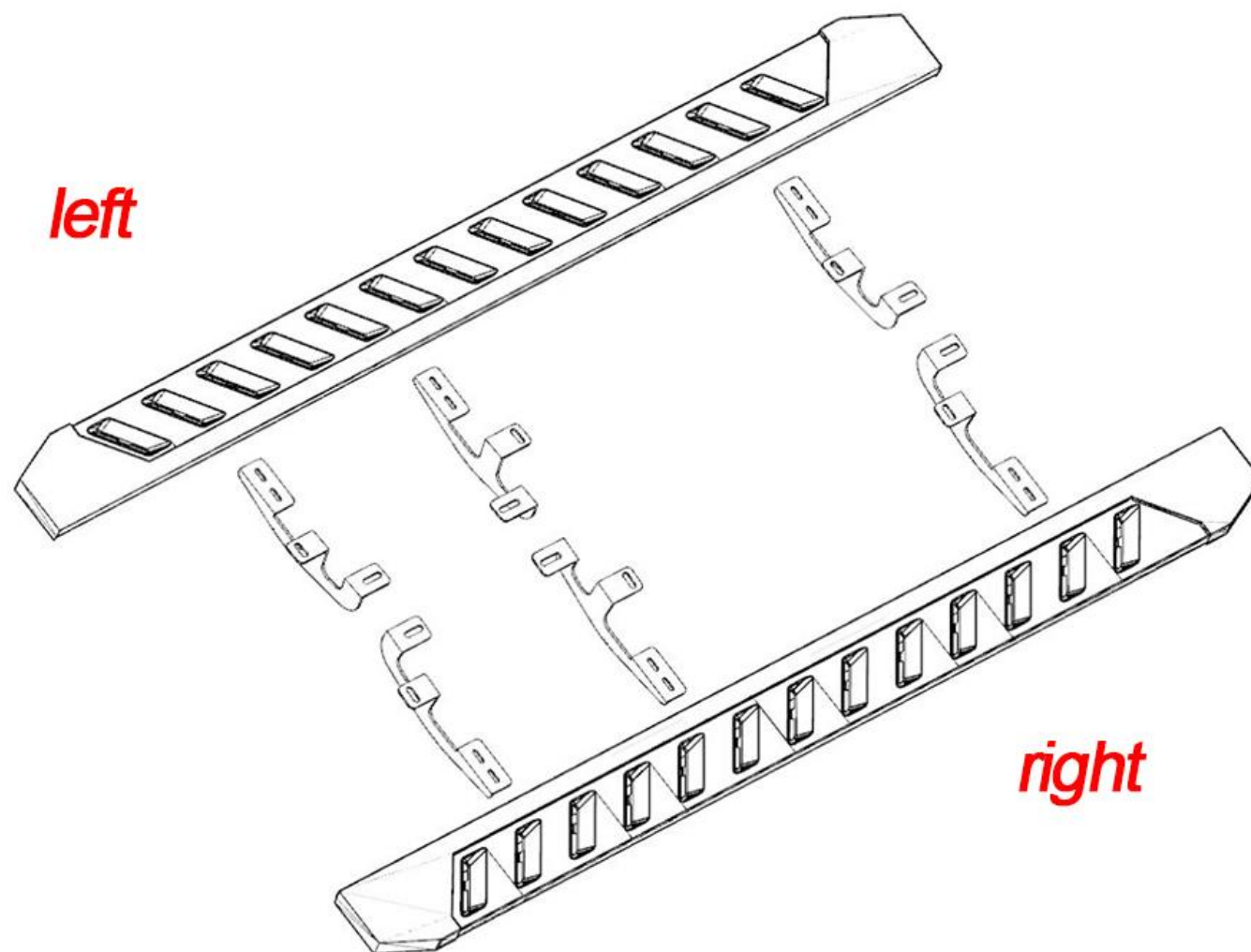

2. Use a flat screw to remove the 3 plastic panels on the side and then remove the nuts and screws on the bottom of the side skirt.

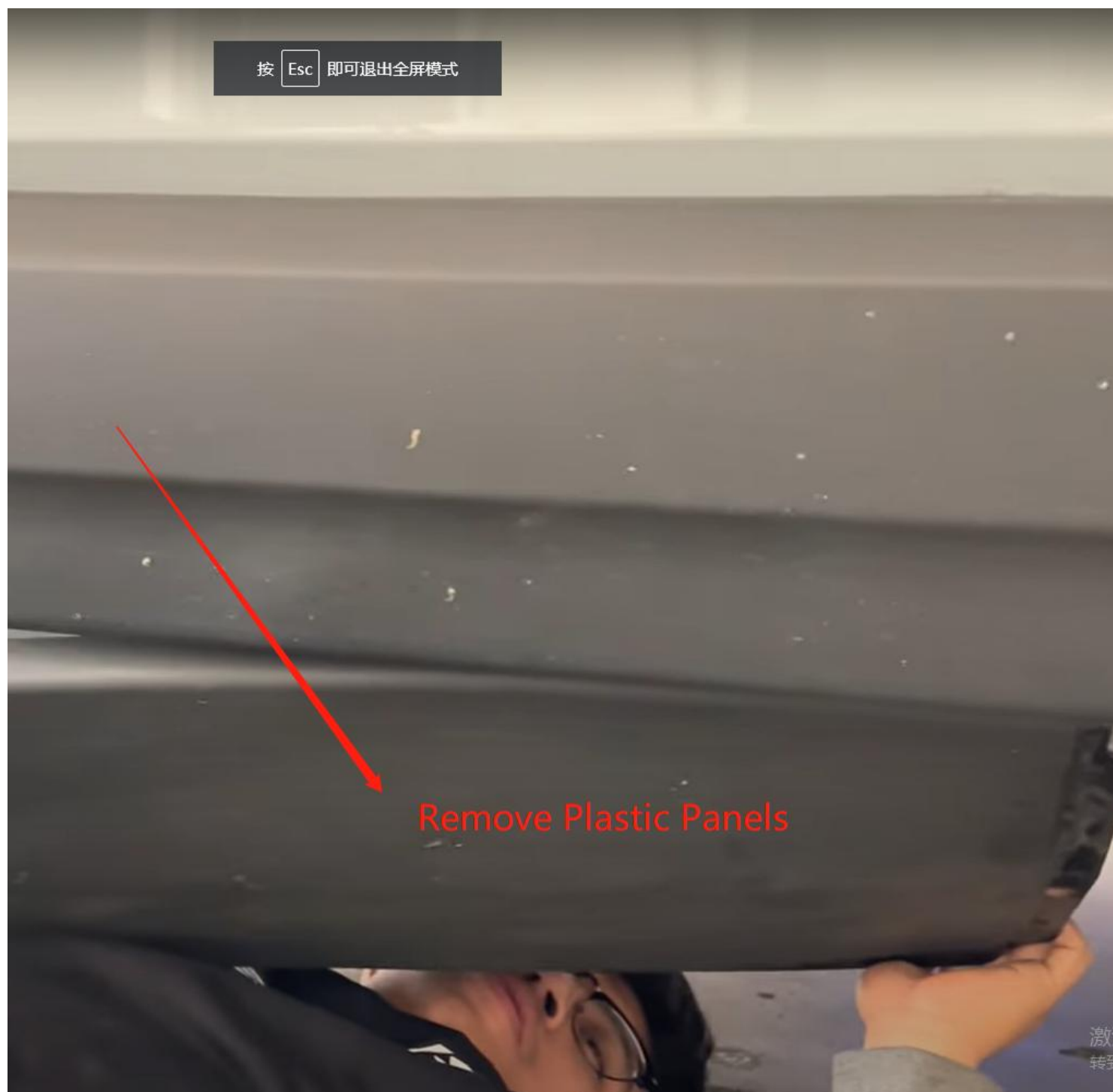

Installation Steps Cont.

3. Starting on the driver side front of the vehicle, partially attach driver/front Mounting Bracket to vehicle using our M10 screw. Then reinstall the original car screws and nuts.

Installation Diagram to reinstall the original car screws and our screws.

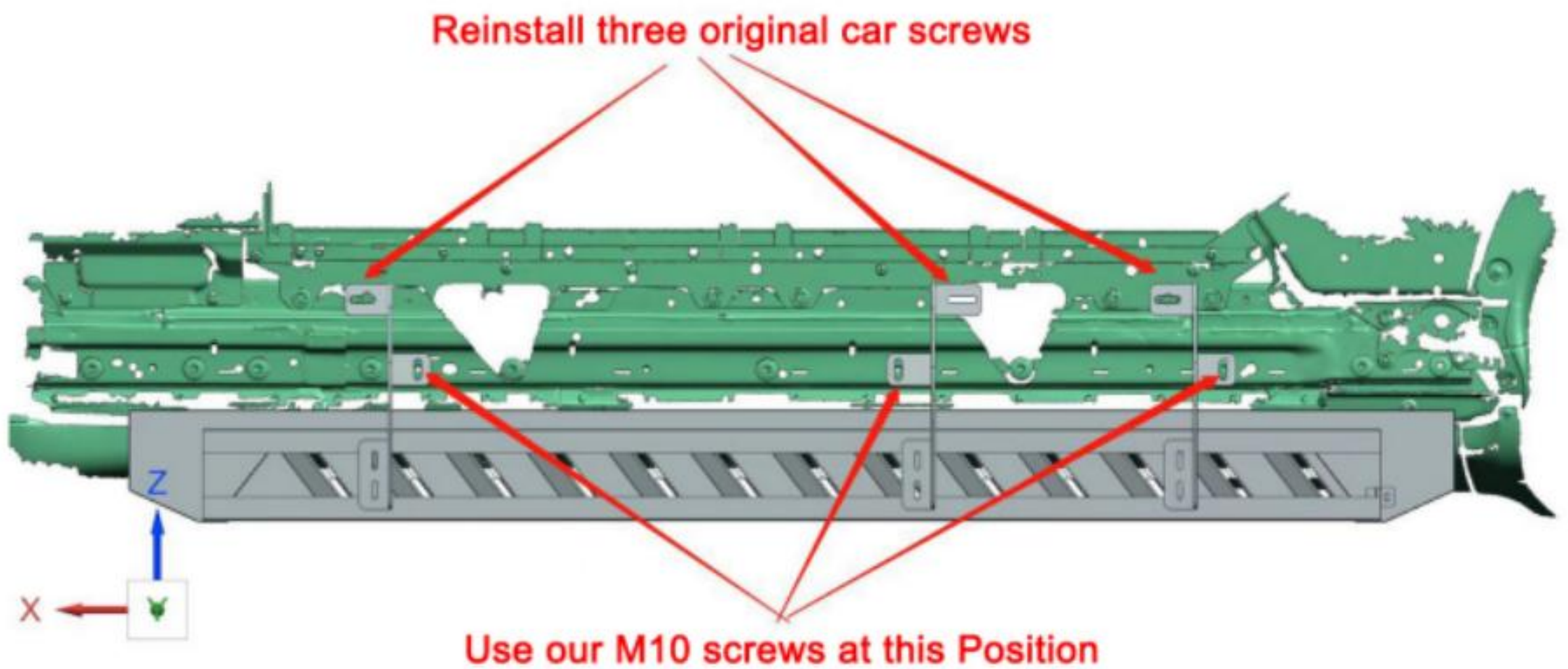

Driver Side Front Bracket

Center & Rear Bracket

Front Bracket

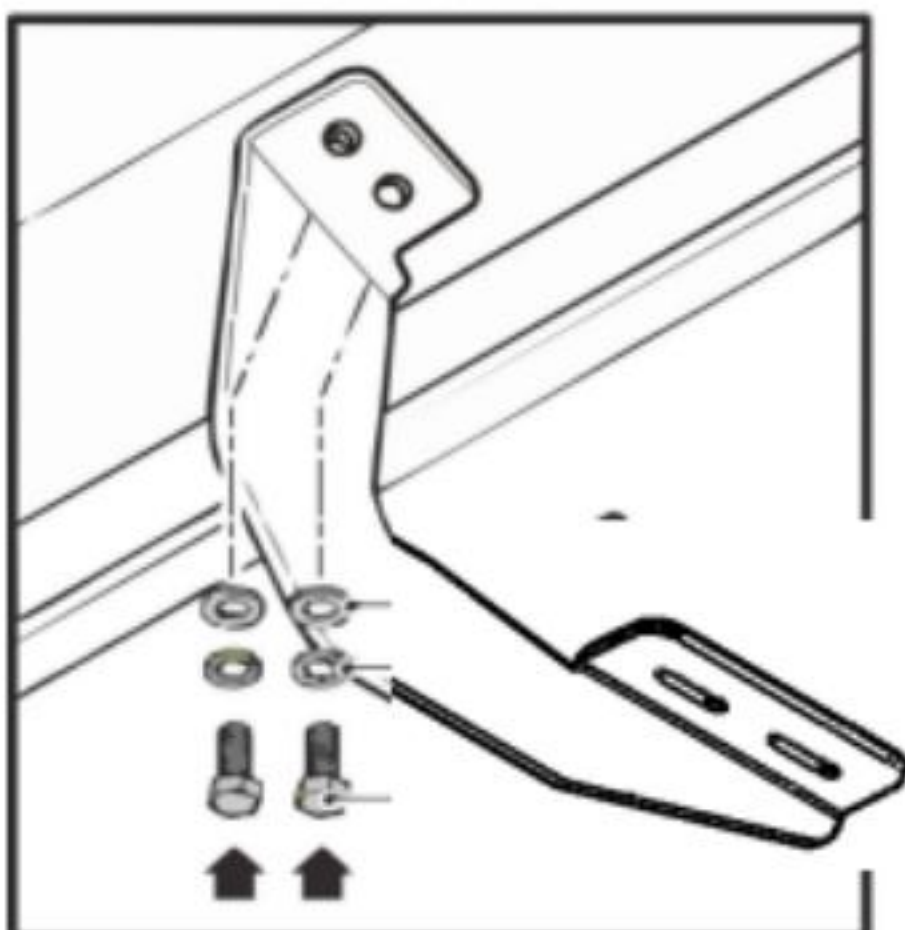

- M8 FLAT WASHER
- M8 LOCK WASHER
- M8*30MM
- HEX HEAD BOLT

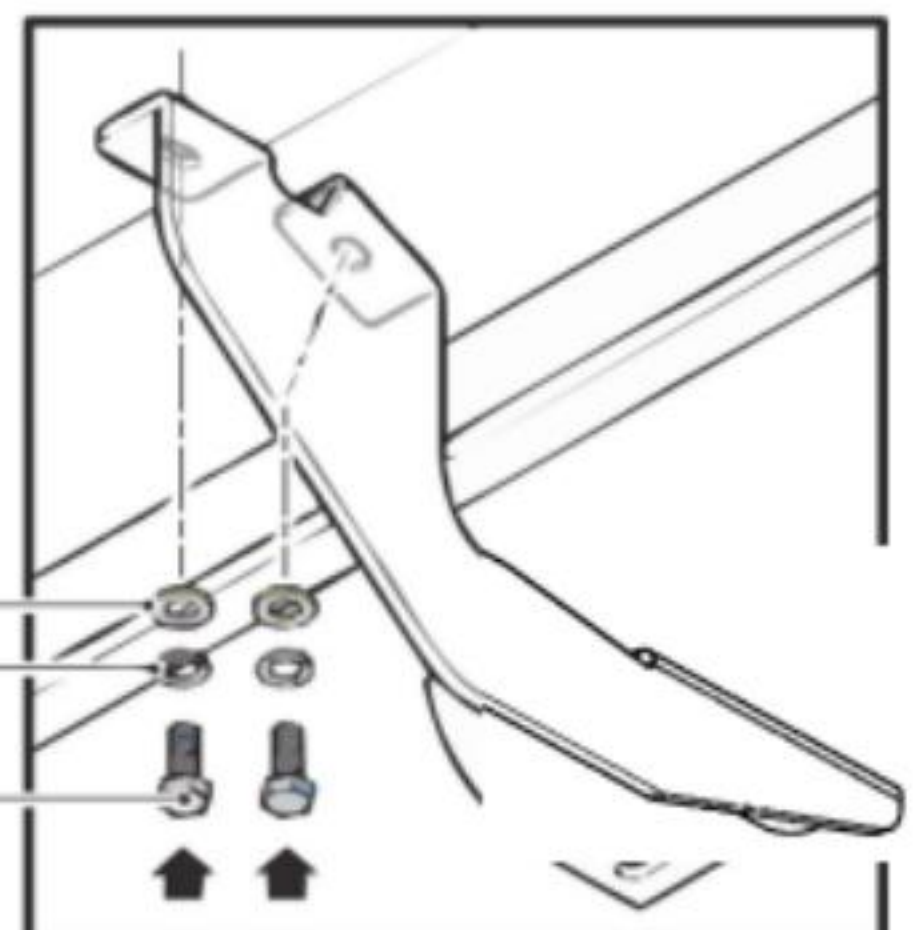

Installation Steps Cont.

4. Repeat the above step for the middle and rear mounting brackets. Install three brackets on each side of the car. Install the corresponding bracket according to the serial number in the packing list.

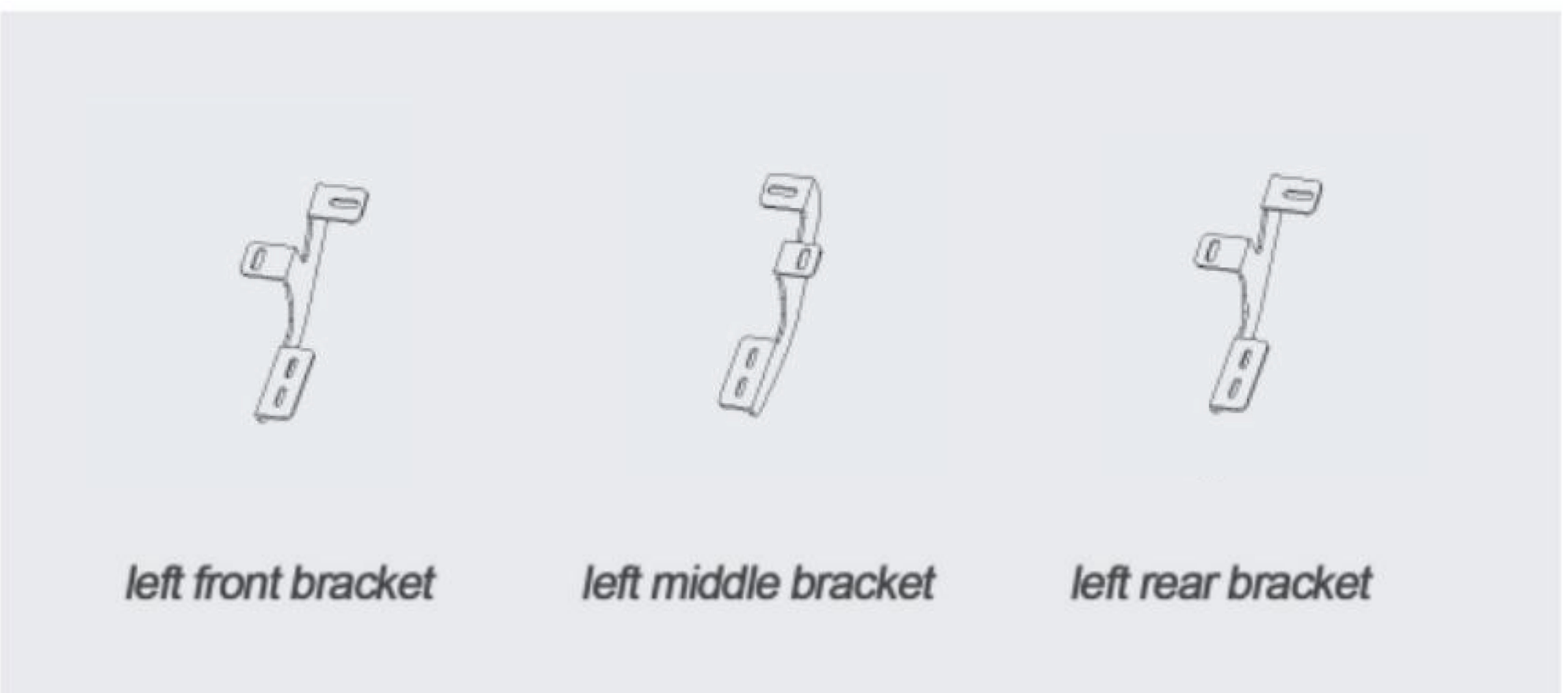
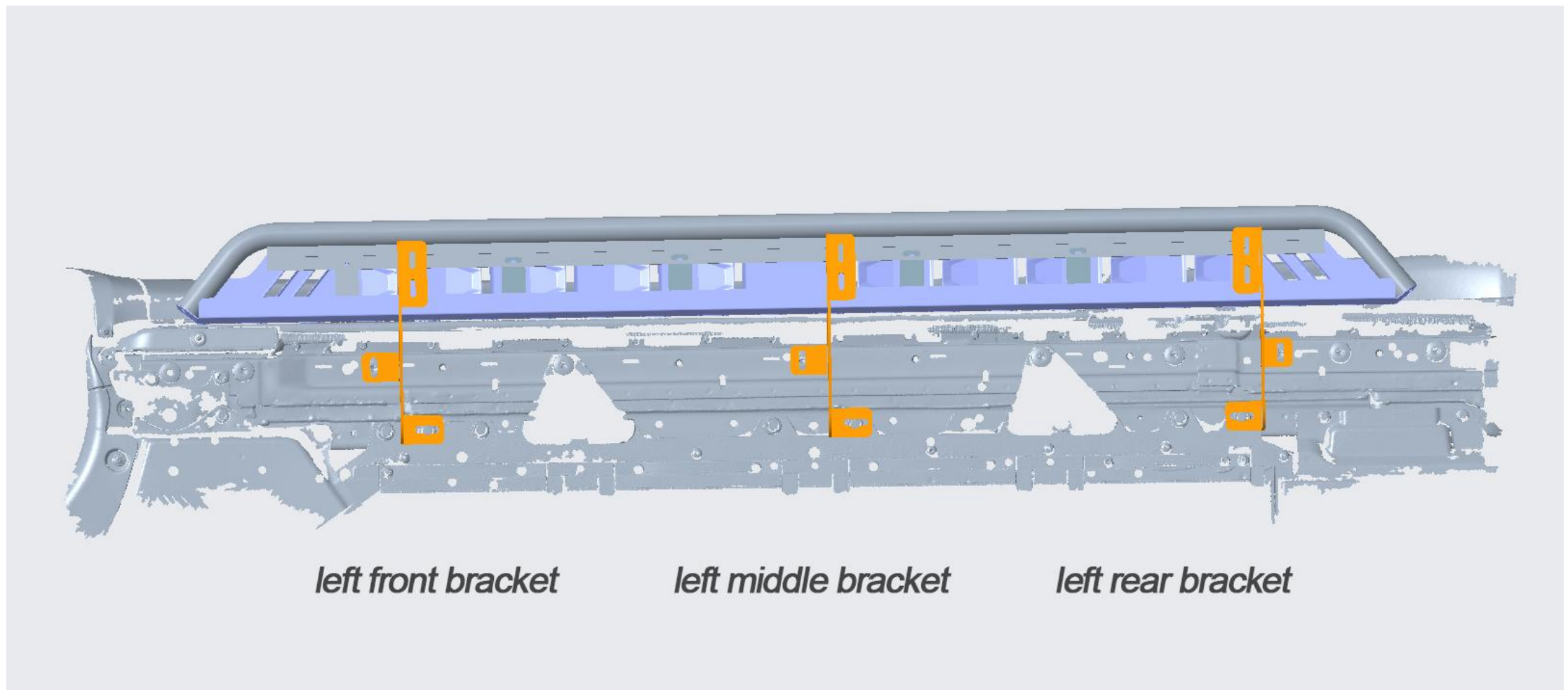

Installation Steps Cont.

5. Cut off the extra plastic panels according to the following diagram. If you want to reinstall the 3 plastic rocker panels around the bracket, please watch our installation video where we explain in greater detail.

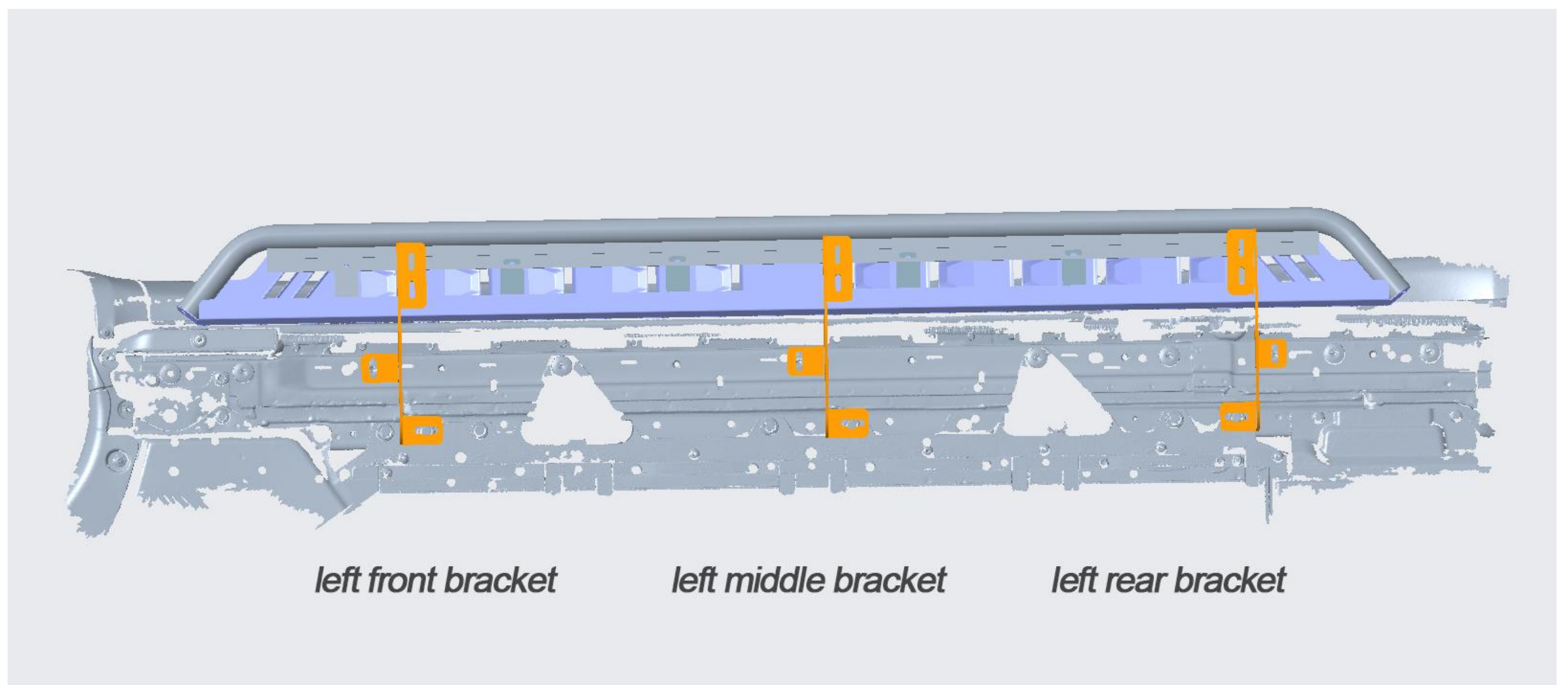
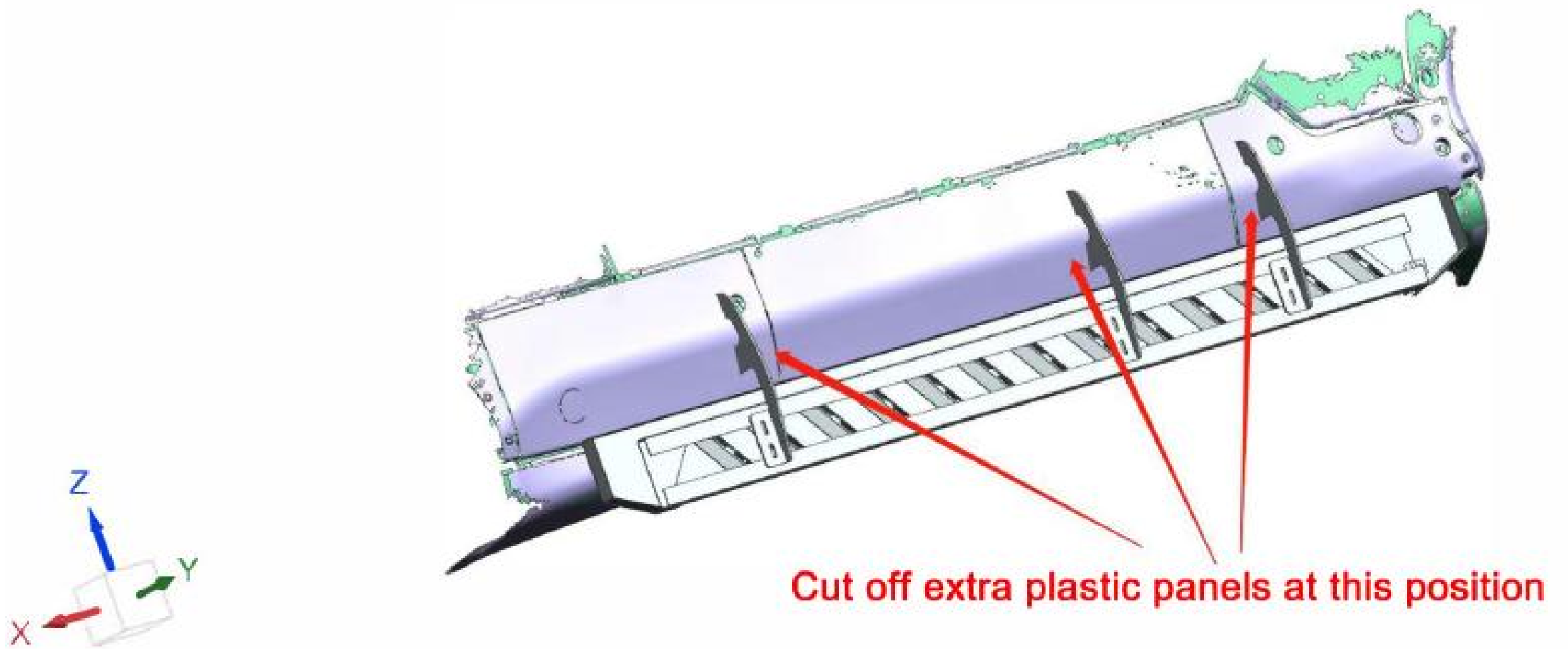

Installation Steps Cont.

6. Install the left and right Running Boards with the M8 screws, nuts, and locking washer. Tighten the screws of each part, reinstall the plastic plate on the bottom complete installation.



Simple Installation Steps

1. Remove the left and right side bottom guards at the pedal installation position.
2. Find the corresponding bracket installation position on the car.
3. Cut off the part where the bottom guard plate interferes with the bracket and install the bottom guard plate.
4. Install the pedal to the bracket that you just finished installing.

IMPORTANT NOTE(Maintenance)

To Protect your investment: Do not use any type of polish or wax that may contain abrasives that could damage the finish.

For the Running Boards: Aluminum polish may be used to polish small scratches and scuffs on the finish. Mild soap may be used to clean the sidebar.

For finishes: Mild soap may be used to clean the sidebar.

WARRANTY and SUPPORT

Email: rpmrivian@gmail.com

Phone/Message: +1 949-346-2077

GET MORE SUPPORT



Scan QR code to watch our installation video

