

WOTS

WHEELCHAIR OCCUPANT TIEDOWN SYSTEM

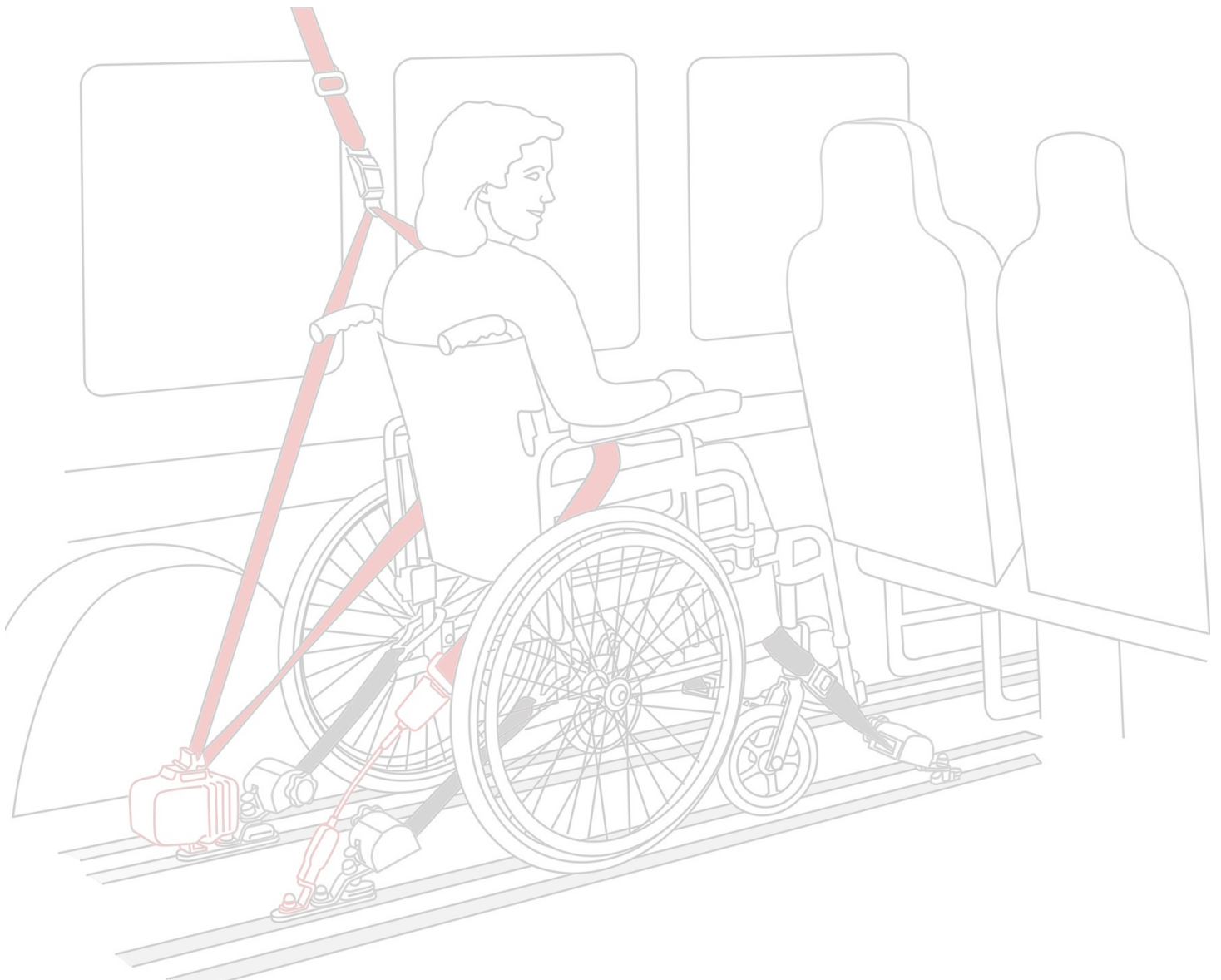

WOTS – 1 SERIES

USER INSTRUCTIONS

Step 1: Restraining the wheelchair

- Ensure that the wheelchair is positioned facing forward in a secure location. Then, either engage the wheel locks or turn off the power.
- Attach the tie-downs to the floor anchors (refer to Figure 1) and ensure they are firmly secured in place.
- Securely attach the four tie-down hooks to sturdy sections of the frame or nearby metal structures close to the seating area. Ensure that the tie-downs are positioned at approximately a 45-degree angle and align with the angles depicted in Figure 2. Avoid connecting the hooks to the wheels, plastic components, or detachable parts of the wheelchair.
- Ensure that all tie-downs are securely locked and appropriately tensioned. If needed, gently rock the wheelchair back and forth or manually adjust the tension on retractor knobs (if available) to remove any excess slack in the webbing



WARNING

- Do not allow webbing to get twisted inside retractors.
- Wheelchair accessories and equipment should be properly secured or removed from the wheelchair and secured in the vehicle during transportation.
- Whenever possible, items attached to the wheelchair in front of the passenger should be removed and secured separately during transportation.

Fig 1: Floor Anchorages

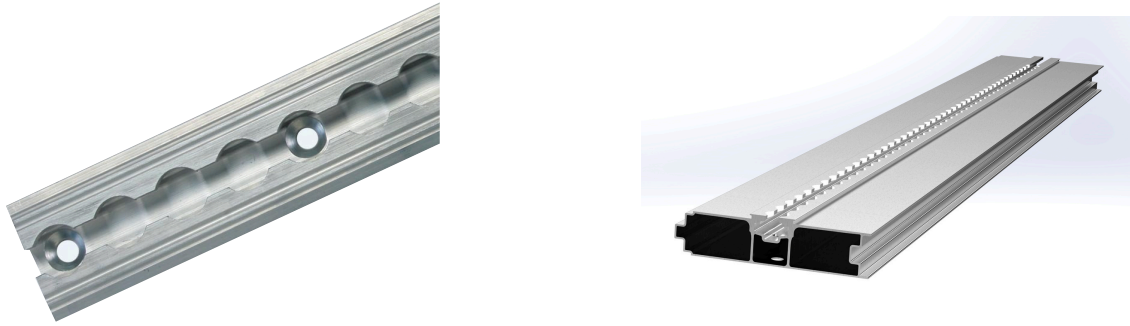
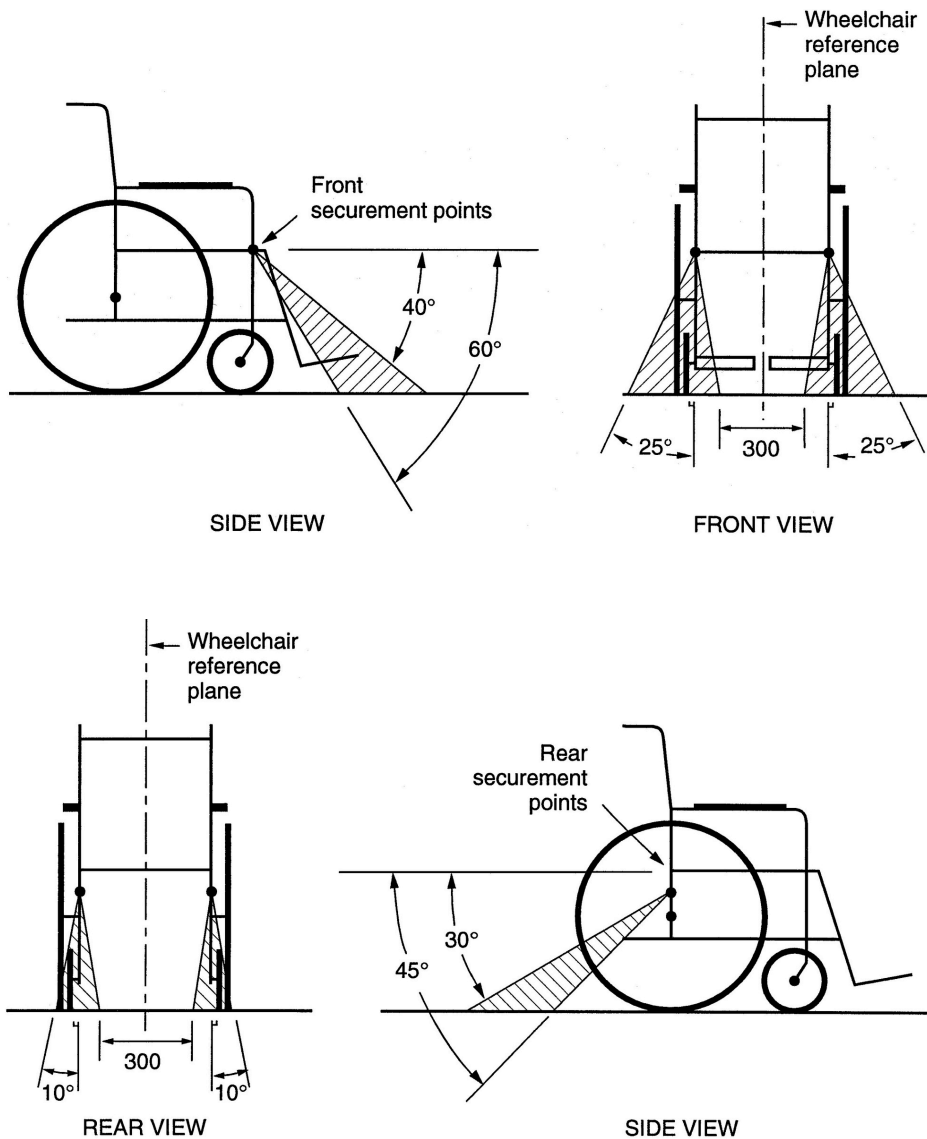

Fig 2: Tie-Down Angles



Step 2: Pelvic and shoulder belt attachment

- Secure the lap belt connector's Buckle (1) to the rear tie-down belt tongue (2) on the window side, following the configuration depicted in Figure 4. Ensure that the buckle rests on the passenger's hip.
- Guide the shoulder belt across the passenger's shoulder and upper torso. Secure the belt's buckle (1) to the rear tie-down belt tongue (2) on the aisle side, following the illustration in Figure 4. On the opposite window side, join the belt tongue with the lap belt buckle.

Fig.4

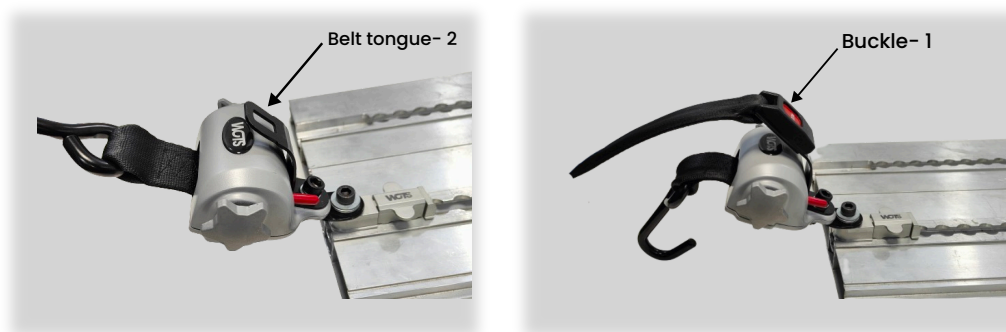

WARNING

- Lap and shoulder belt should not be held away from passenger's body by wheelchair components or parts such as the wheelchair's wheels, armrests, panels or frame (Fig.5).
- Never rely on wheelchair's lap belt or a postural support belt unless properly approved & crash tested.
- Ensure belt webbing is not twisted while being worn by passenger.
- Occupant belts should always bear upon the bony structure of passenger's body and be worn low across the front of the pelvis, with the junction between lap and shoulder belts located near passenger's hip.

FIG.3: Occupant Restraints

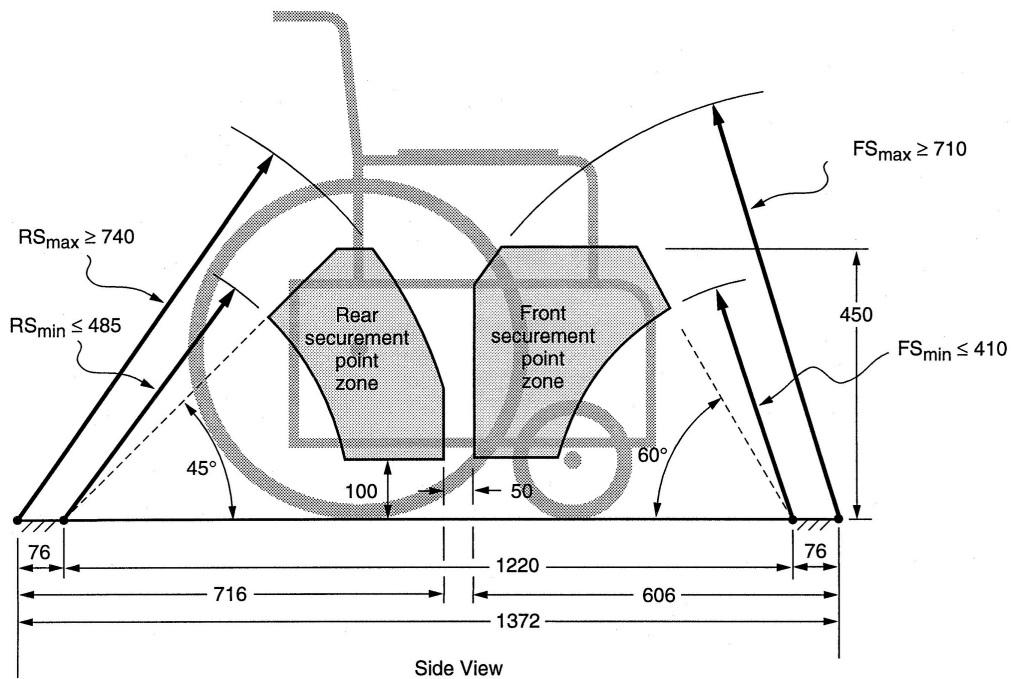
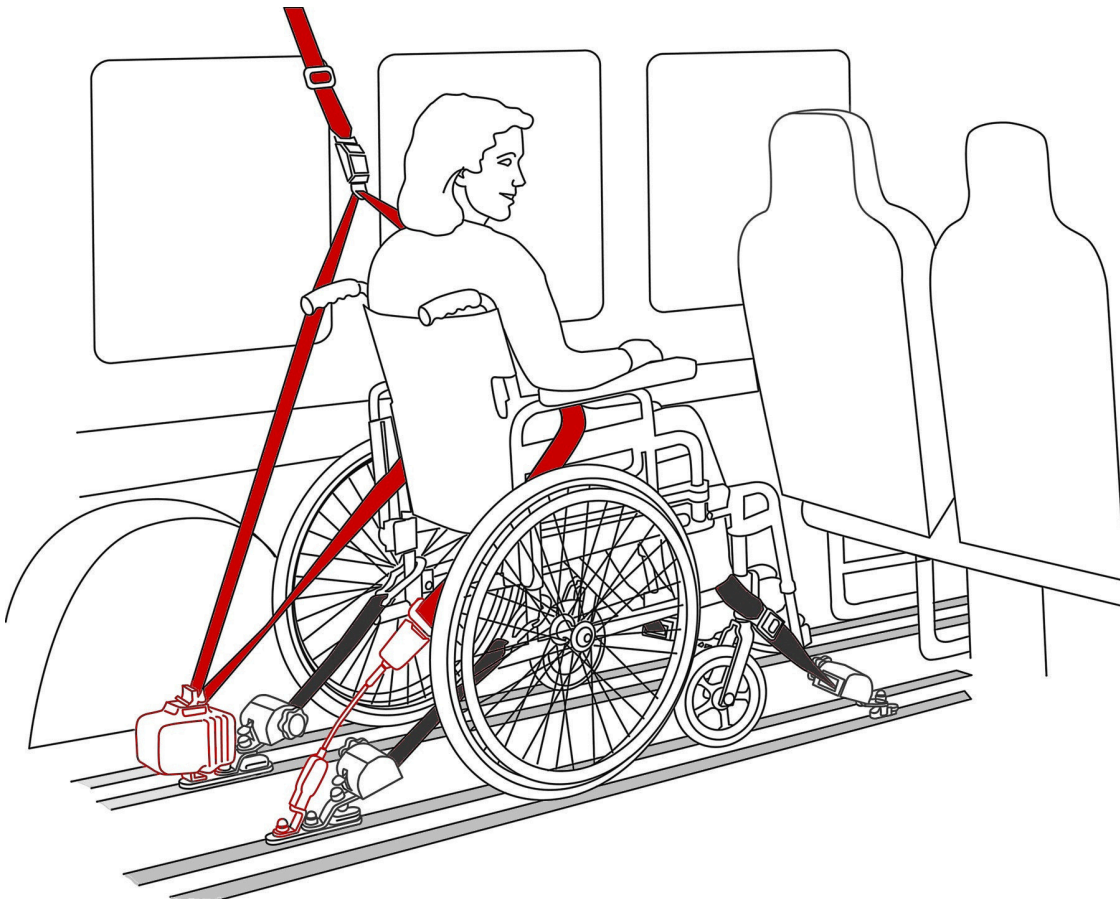

Step 3: Release occupant /wheelchair

- Carefully detach the passenger's shoulder and lap belts, following the steps in reverse from Step 2 above.
- Release the front and rear tie-downs from the wheelchair by pressing the red release lever on the retractors, or by activating any remote release or time-delay equipment.
- Unlock the wheels or turn on the power, then guide or move the passenger out of the wheelchair securement area.

Release lever- 3



**RESTRAINTS SHOULD NOT BE HELD AWAY FROM
BODY BY WHEELCHAIR COMPONENTS**



MAINTENANCE & CARE

- Ensure that belts are kept clean and off the floor.
- All systems and components should undergo regular inspections, cleaning, and maintenance.
- Regularly clean the webbing using mild soap and water. After cleaning, fully extend the belts and ensure they are positioned to prevent water from entering the retractors until they are thoroughly dry. Be vigilant to avoid contaminating the webbing with polishes, oils, or any other chemicals, especially battery acid. Occasionally, lubricate any buckles or fittings, taking care not to contaminate the webbing.
- If bolts undergo adjustment, ensure thorough cleaning of the bolt threads and re-application of permanent thread locker.
- Replace any frayed, contaminated, or damaged webbing immediately.
- Any systems or components exhibiting signs of missing parts, excessive damage or wear, or suspected use during a vehicle accident, from which the vehicle has been towed, should be replaced.



WARNING

- The systems should solely be utilized with forward-facing wheelchairs. WOTS 4-Point Securement systems and components adhere to all relevant safety regulations and standards, including ADA, FMVSS & CMVSS 209/210/222/302, WC18/19, CSA Z605 & D409, AS - 2942-1994, CE Directive 93/42/EEC, SAE J2249, and ISO 10542.

*The systems undergo dynamic crash testing at speeds up to 30mph (45kph) and 20g, utilizing an 85kg forward-facing surrogate wheelchair and a 76.3kg Anthropomorphic Test Dummy (ATD). The ATD is restrained by both lap (pelvic) and shoulder (upper-torso) restraints. It's important to note that using only a lap restraint may compromise the system's performance.

*Please note that the 'A'-Series track has not been tested to comply with SAE J2249 & ISO 10542.

- The Wheelchair Securement System should be utilized following the instructions provided.
- Avoid combining parts and components from different manufacturers to assemble a complete system.
- Notify your supervisor of any potential damage or defects. If you have any questions regarding the installation or use of wheelchair and occupant securement systems or components, please consult your nearest WOTS office.
- For additional instruction and details, please refer to the User Instruction Booklet for 4 - Point Systems.



WGTS

WHEELCHAIR OCCUPANT TIEDOWN SYSTEM

If you have any questions, comments and concerns, or need additional information,
please do not hesitate to contact us at any of the following locations:

If you have any questions, comments and concerns, or
need additional information, please do not hesitate to
contact us at any of the following locations:

USA

Garet Lee

Operation Director

(248)-864-8185

garet.lee@paretoas.com

21455 Melrose Ave., Suite 19,
Southfield, MI 48075

