

## Application Note – How to use LED Flexible Light Strips

LED Flexible Light Strips are wound on reels like movie film and are 5 meters (16.4 feet) long. They are low voltage and operate off 12 Volt DC power. The backside of the strip has a protective cover over 3M adhesive. The strips are Peel and Stick so you can attach them to any surface to which you can apply tape. Like tape, these LED strips can be cut to the length you need with scissors. These strips have a marked line every 3 LEDs, approximately every 2 inches, where you can cut the strip. Determine the length, find the nearest cutting line, and carefully cut exactly along the line. Whether you are cutting strips to put beneath your kitchen cabinets, lighting a display case or curio cabinet, or bringing light to your multi-level model railroad layout, you can adjust the length to what you need.

When cutting LED strips to length, you must also consider the power connections. All of our single-color LED reels have a barrel jack electrical connector attached to one end that can plug directly to the barrel plug connector of our #85501 power supply. Our Multi-Color LED strip comes with a 4-pin connector on one end of the strip that plugs into one of our color controllers, #85688 or #85552. Our color controllers also have a barrel jack connector which allows you to easily connect to our #85501 power supply. This is a simple way to power the LED Light Strip. When using only a part of the light strip and not the entire length, first use the end that has the connector already attached. Use one of our solderless clip-on connectors to power cut sections of LED strips. Look closely on both sides of a cutting line. On our single color LED strips, there are two pads, which are the power connections for the strip. One pad has a “+” next to it, and the other pad has a “-” next to it. This indicates the positive (+) and negative (-) connections for the 12 Volt DC power. These pads are the connections for our clip-on strip connectors. Our Multi-Color strips have four pads next to each cut line (see below).

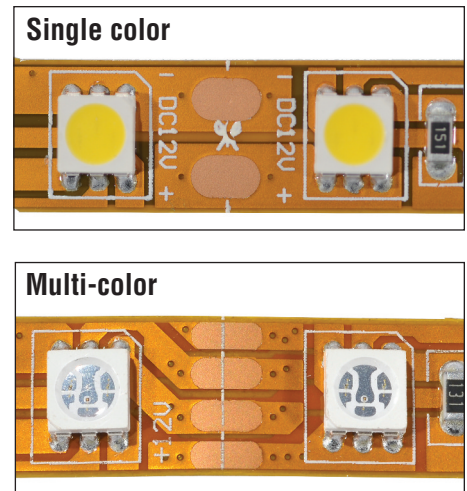
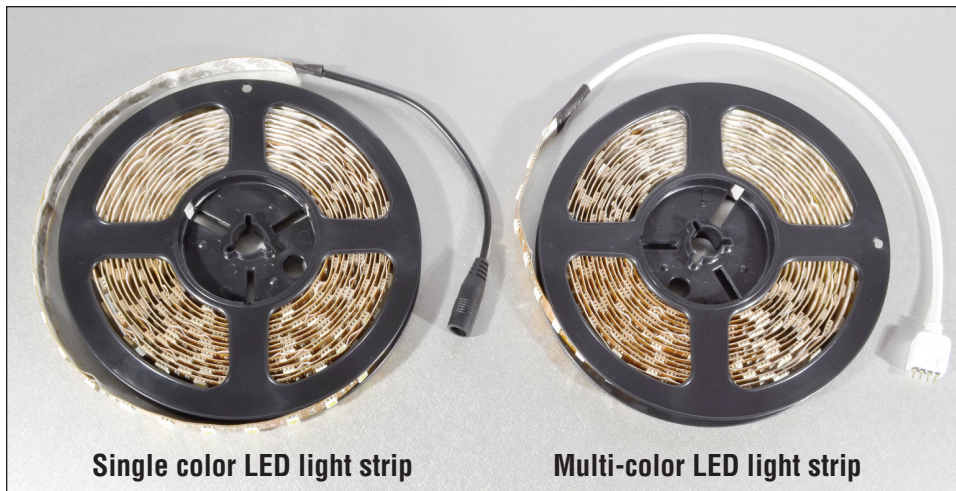

### Choosing a Color

Single-color LED strips come in several colors, plus three varieties of white LED strips. White LED strips are available in three color temperatures: 5000°K (Bright White); 4200°K (Neutral White) and 2800°K (Warm White). The white to choose is mostly a matter of personal preference, but here are some guidelines: Most people prefer the Bright White for lighting curio cabinets...particularly when there are crystal figures to display. Warm White is similar to incandescent lighting and is usually preferred beneath kitchen cabinets. Neutral White works best for lighting outdoor dioramas or model railroad layouts, since it produces color renditions similar to natural outdoor lighting. Using two strips, one Bright White and one Warm White, will also produce a neutral white effect.

### Using our Solderless Strip Connectors with Flying Leads (#85498 and #85560)

If you are going to power a cut length of the LED Strip, you can easily use one of our solderless connectors to make electrical connections to the power pads. Open the connector end (opposite the wires) by lifting the small plastic latch that holds the connector closed. Peel back a small portion of the adhesive backing paper (about ¼ inch). Insert the end of the LED Strip into the slots in the connector, under the metal contacts, and snap the cover of the connector closed.

On single color strips, make sure that the red wire side of the connector goes to the “+” pad, and the black wire side of the connector goes to the “-“ pad. On Multi-Color strips, make sure that the black wire side of the connector goes to the pad marked “+12” (You may have to turn the strip upside down to do this properly for both types of strips). For single color strips, connect the red wire to +12 VDC and the black wire to the negative screw terminals of a power supply, LED Strip Dimmer, or Barrel Jack adapter.

Multi-Color strips have four connections; one for the +12V power, and one each for the Red, Green, and Blue color channel return connections. Extend the wire leads, if necessary, with 22 AWG wire. Our #84109 ScotchLok connectors can be used to make quick connections. For LED strip lengths of 10 feet or less, our #85511 (red) and #85512 (black) 24 AWG flexible wire can be used; it has a thin FEP insulation and fits into tighter places than typical PVC insulated wire.

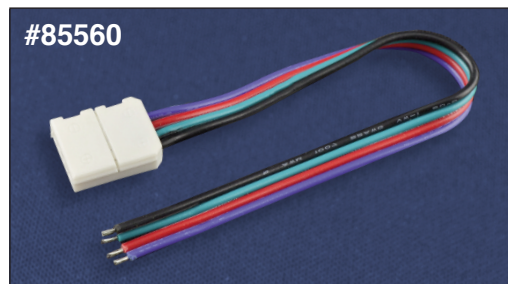
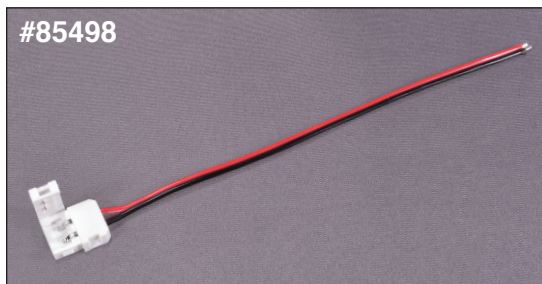

### Using our Solderless Strip-to-Strip Wired Connectors (#85499 and #85561)

Installing two LED Flexible Strips at any angle to each other is easy with our strip-to-strip wired connector. Separated by 5 inches of wire, the two connectors let you connect two strips and mount at any angle to each other. Follow the same LED strip connection procedure as our Flying Lead connectors.

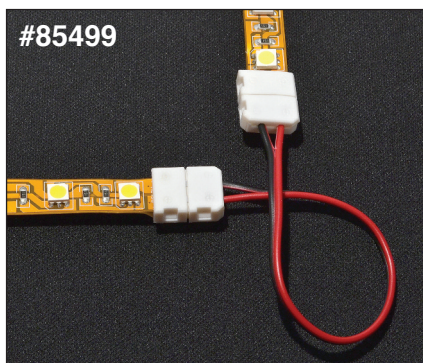

### Using our Solderless LED Strip Couplers (#85500 and #85562)

Use our strip coupler to closely connect two strips together with a minimal gap between LEDs. Open the two sides of the connector by lifting the small plastic latches that hold the connector closed. Peel back a small portion of the adhesive backing paper (about 1/4 inch) on each strip. Insert the ends of the two LED Strips into the slots in both sides of the connector and under the metal contacts. Make sure that the “+” pad one strip lines up on with the “+” pad on the other strip.

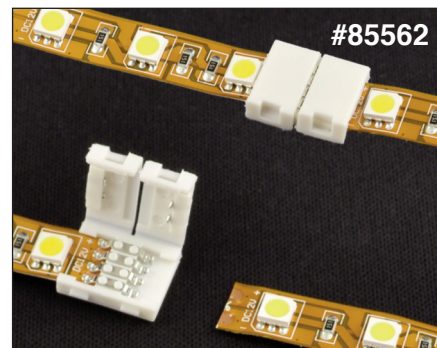
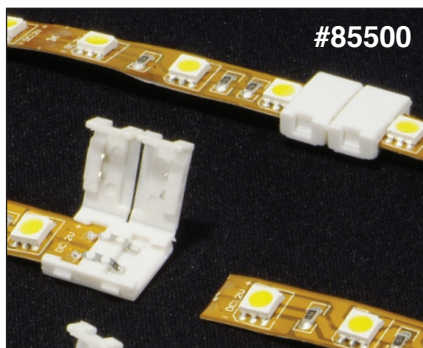

### Dimming the Brightness of LED Strips

Our #85503 LED Strip Dimmer adjusts the brightness of your single-color LED Strip. It will plug directly into barrel plug of the #85501 Power Supply and barrel jack of single color LED strip. Use #85553 Barrel Plug Adaptor and 22 AWG wire to connect to #85502 Power Supply.

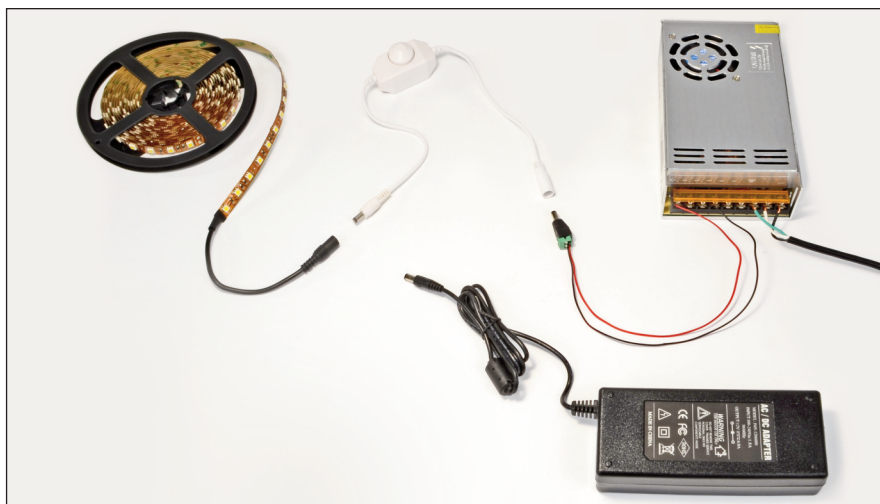

## No more cutting and soldering!

### #85553 2.1 mm Barrel Plug to screw terminals Adapter

These two adapters allow you to connect bare wires to barrel jack connectors. One end has screw terminals and the other has a 2.1 mm x 5.5 mm, center-positive barrel connector. Choose the #85553 Plug or the #85554 Jack as needed for your connections. Be sure to follow the “+” and “-” markings near the screw terminals to ensure the proper polarity. Use any available 20 AWG or 22 AWG wire to make your connections. Shorter lengths of LED strips (under 10 feet) can be powered from thinner 24 AWG wire.

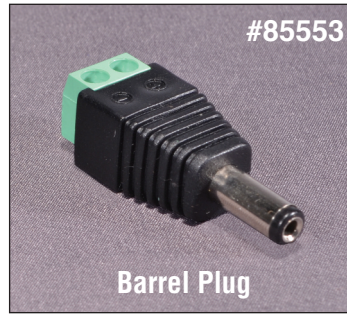

### #85554 2.1 mm Barrel Jack to screw terminals Adapter



## Power Supplies

A full reel (5 meter) LED strip at full brightness requires 6 Amps at 12 VDC. Our #85501 Power Supply provides this power and can operate one full LED strip. To power more than 5 meters of LED strip lights, use two (or more) of our #85501 power supplies. We also offer our #85502 power supply that provides up to 33 Amps at 12 VDC and can operate up to five full reels (25 meters) of LED strips. It uses a terminal strip with 3 pairs of 12V connections for direct wiring of LED strips.



## Color Controller for Multi-Color LED Strips

Each LED chip on the Multi-Color strip actually contains three individual LEDs; one red, one green, and one blue. Any color can be produced by varying the intensity of the individual color channels. Our color controller can select specific colors or create various color effects and sequences by combining colors. Color controller comes with a wireless (infrared) remote control. The control box has a barrel jack connector for the power supply. The infrared sensor is on a short length of wire which lets you place the control box out of sight while keeping the sensor visible to the remote control. The 4-pin connector plugs into the Multi-Color LED strip: Just line up the arrows on the two connectors. Use the remote control to set colors or run sequences.



### **Micro-Mark Tip:**

When powering LED Light Strips, you may find that the lights are brighter at one end of the strip than at the other, especially when you have multiple light strips connected in a daisy-chain (end to end) fashion. To balance the light output, you'll need to provide additional power feeds to the connection points between strips. You may also feed the power into the center of the string, or feed from both ends, or at various points along the string of strips. Be sure to connect all (+) connections together and connect all (-) connections together; otherwise, you will short out the power supply.

**Micro-Mark**<sup>®</sup>  
THE SMALL TOOL SPECIALISTS

340 Snyder Avenue, Berkeley Heights, NJ 07922

www.micromark.com • Tech Support: 908-464-1094, weekdays, 1pm to 5pm ET • MMTechService@micromark.com