

# EQUAL LEG ANGLES

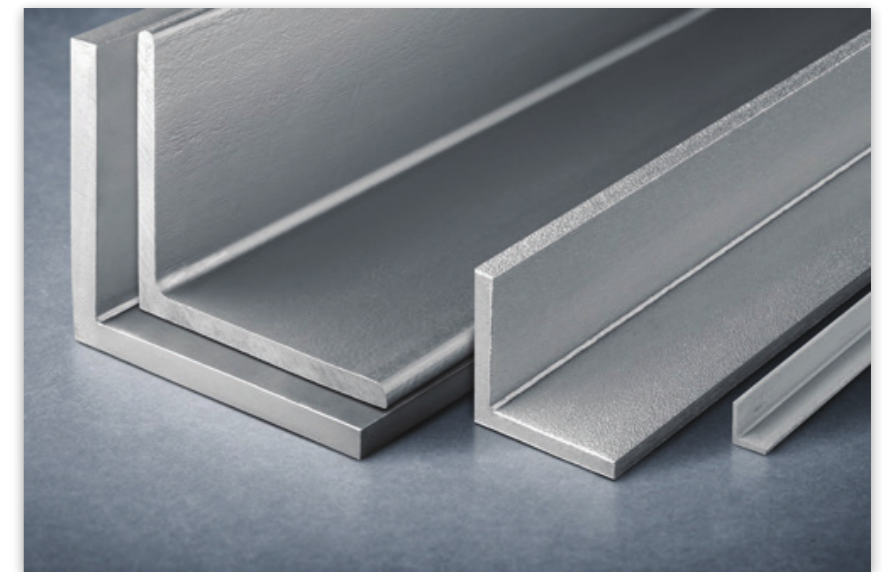

# L EQUAL LEG ANGLES

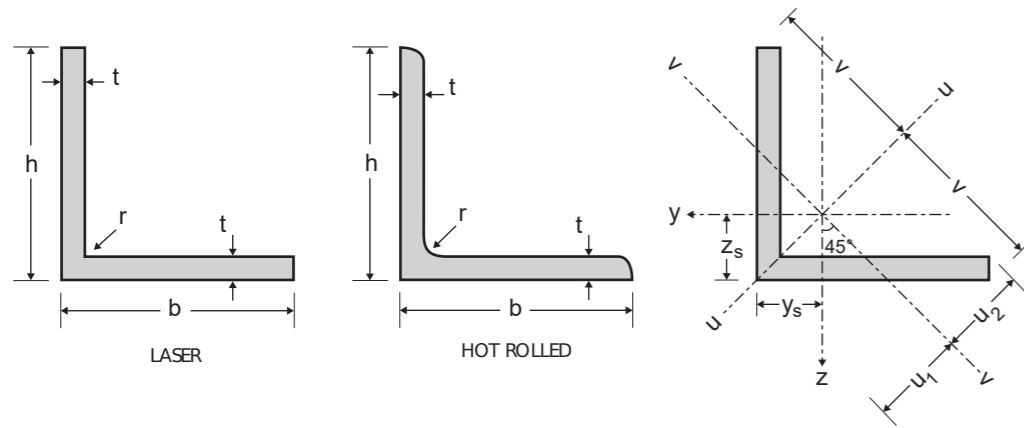

## STAINLESS STEEL

### Product Description

Dimensions: in accordance with EN 10056-1: 1998  
 Tolerances: EN 10056-2:1993.  
 Grade according to EN 10088-3: 1D  
 Surface condition: blasted and pickled

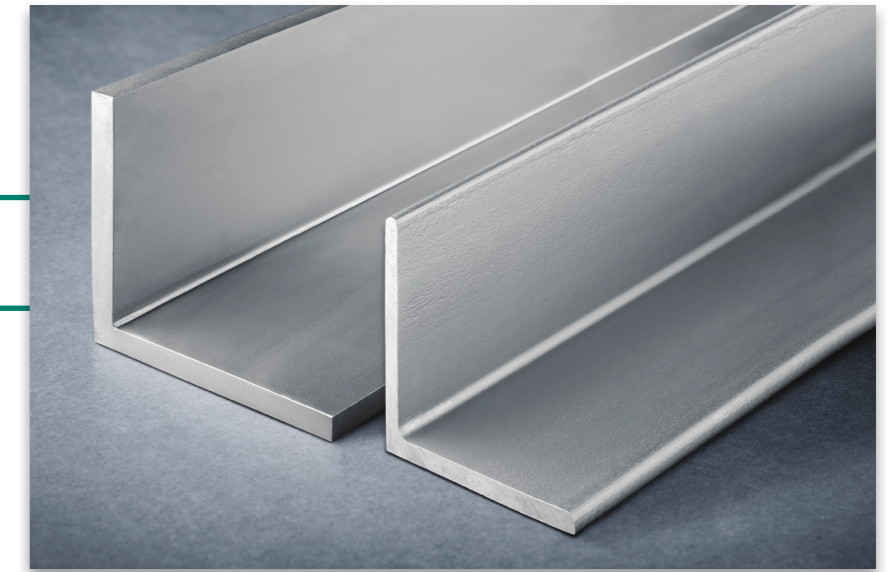

General properties										Structural properties							
Designation		Dimensions				Position of axes				Axis y-y / axis z-z			Axis u-u		Axis v-v		
	G kg/m	h=b mm	t mm	r mm	A mm <sup>2</sup> x10 <sup>2</sup>	z <sub>s</sub> =y <sub>s</sub> mm	v mm	u <sub>1</sub> mm	u <sub>2</sub> mm	I <sub>y</sub> =I <sub>z</sub> mm <sup>4</sup> x10 <sup>4</sup>	W <sub>el,y</sub> =W <sub>el,z</sub> mm <sup>3</sup> x10 <sup>3</sup>	i <sub>y</sub> =i <sub>z</sub> mm x10	I <sub>u</sub> mm <sup>4</sup> x10 <sup>4</sup>	i <sub>u</sub> mm x10	I <sub>v</sub> mm <sup>4</sup> x10 <sup>4</sup>	i <sub>v</sub> mm x10	I <sub>yz</sub> mm <sup>4</sup> x10 <sup>4</sup>
L 15 x 15 x 2	0.45	15	2	2.5	0.57	4.39	10.61	6.21	5.29	0.11	0.11	0.45	0.18	0.56	0.05	0.29	-0.07
L 15 x 15 x 3	0.66	15	3	3	0.82	4.76	10.61	6.73	5.37	0.15	0.15	0.43	0.24	0.54	0.07	0.29	-0.09
L 20 x 20 x 2	0.61	20	2	2.5	0.77	5.64	14.14	7.97	7.07	0.28	0.20	0.61	0.45	0.76	0.12	0.39	-0.17
L 20 x 20 x 3	0.90	20	3	3.5	1.12	5.98	14.14	8.46	7.08	0.39	0.28	0.59	0.62	0.74	0.16	0.38	-0.23
L 20 x 20 x 4	1.16	20	4	3.5	1.45	6.37	14.14	9.01	7.24	0.49	0.36	0.58	0.77	0.73	0.21	0.38	-0.28
L 25 x 25 x 3	1.14	25	3	3.5	1.42	7.23	17.68	10.22	8.85	0.80	0.45	0.75	1.27	0.95	0.33	0.48	-0.47
L 25 x 25 x 4	1.48	25	4	3.5	1.85	7.62	17.68	10.78	9.01	1.02	0.59	0.74	1.61	0.93	0.43	0.48	-0.59
L 25 x 25 x 5	1.82	25	5	5	2.28	7.93	17.68	11.22	8.96	1.19	0.70	0.72	1.87	0.91	0.51	0.48	-0.68
L 30 x 30 x 3	1.39	30	3	5	1.74	8.35	21.21	11.81	10.49	1.40	0.65	0.90	2.22	1.13	0.59	0.58	-0.82
L 30 x 30 x 4	1.81	30	4	5	2.27	8.78	21.21	12.42	10.58	1.80	0.85	0.89	2.85	1.12	0.75	0.58	-1.05
L 30 x 30 x 5	2.22	30	5	5	2.78	9.18	21.21	12.99	10.73	2.16	1.04	0.88	3.41	1.11	0.92	0.57	-1.25
L 30 x 30 x 6	2.61	30	6	5	3.27	9.56	21.21	13.52	10.90	2.49	1.22	0.87	3.91	1.09	1.08	0.57	-1.41
L 35 x 35 x 4	2.13	35	4	5	2.67	10.03	24.75	14.18	12.36	2.95	1.18	1.05	4.68	1.32	1.23	0.68	-1.73
L 35 x 35 x 5	2.62	35	5	5	3.28	10.43	24.75	14.75	12.50	3.56	1.45	1.04	5.63	1.31	1.49	0.68	-2.07
L 40 x 40 x 3	1.87	40	3	5	2.34	10.84	28.28	15.33	14.04	3.49	1.20	1.22	5.53	1.54	1.45	0.79	-2.04
L 40 x 40 x 4	2.46	40	4	6	3.08	11.20	28.28	15.83	14.04	4.47	1.55	1.21	7.09	1.52	1.86	0.78	-2.61
L 40 x 40 x 5	3.03	40	5	6	3.79	11.62	28.28	16.43	14.14	5.43	1.91	1.20	8.59	1.51	2.26	0.77	-3.17
L 40 x 40 x 6	3.58	40	6	6	4.48	12.02	28.28	17.00	14.29	6.31	2.26	1.19	9.97	1.49	2.65	0.77	-3.66
L 45 x 45 x 3	2.13	45	3	7	2.66	11.84	31.82	16.74	15.75	4.93	1.49	1.36	7.78	1.71	2.07	0.88	-2.85
L 45 x 45 x 4	2.79	45	4	7	3.49	12.35	31.82	17.46	15.74	6.43	1.97	1.36	10.18	1.71	2.68	0.88	-3.75
L 45 x 45 x 5	3.44	45	5	7	4.30	12.79	31.82	18.09	15.81	7.84	2.43	1.35	12.42	1.70	3.26	0.87	-4.58
L 50 x 50 x 3	2.37	50	3	7	2.96	13.08	35.36	18.49	17.53	6.86	1.86	1.52	10.84	1.91	2.88	0.99	-3.98

Other custom sizes are available upon request

# L EQUAL LEG ANGLES

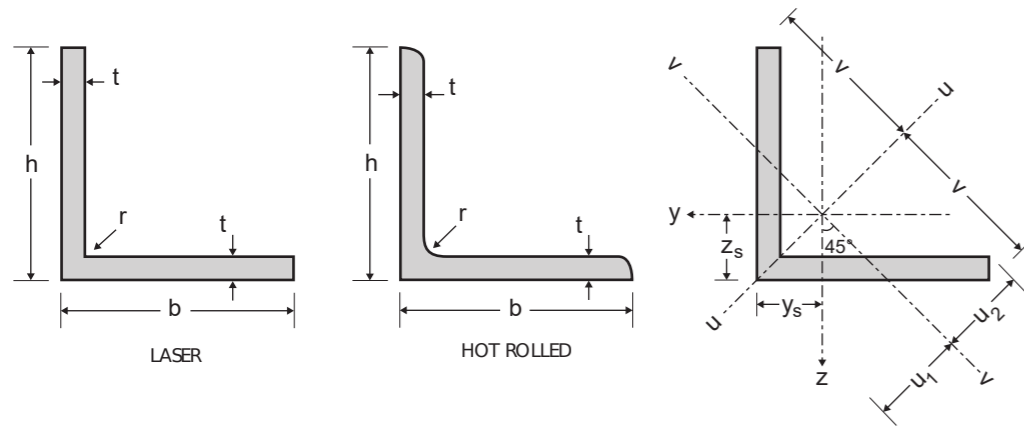

## STAINLESS STEEL

### Product Description

Dimensions: in accordance with EN 10056-1: 1998

Tolerances: EN 10056-2:1993.

Grade according to EN 10088-3: 1D

Surface condition: blasted and pickled

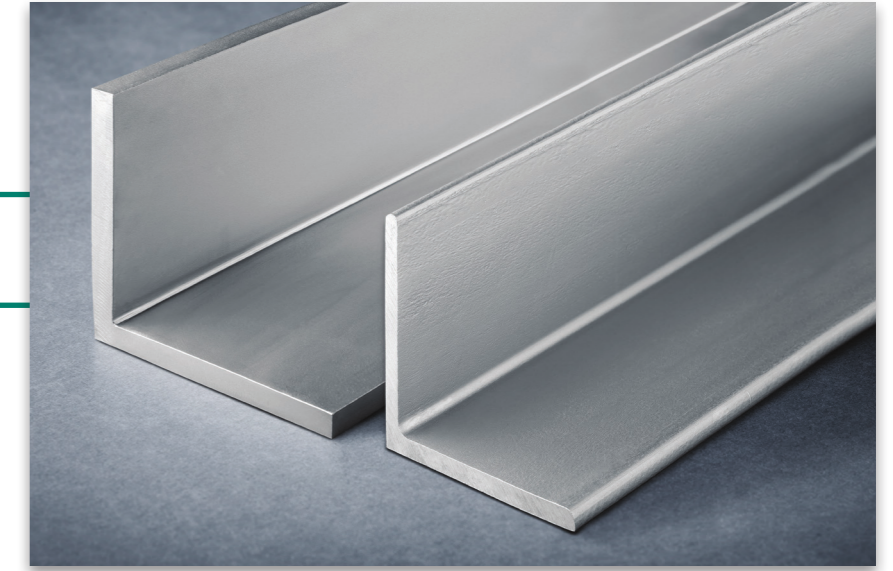

General properties						Structural properties											
Designation		Dimensions				Position of axes				Axis y-y / axis z-z			Axis u-u		Axis v-v		
	G kg/m	h=b mm	t mm	r mm	A mm <sup>2</sup> x10 <sup>2</sup>	z <sub>s</sub> =y <sub>s</sub> mm	v mm	u <sub>1</sub> mm	u <sub>2</sub> mm	I <sub>y</sub> =I <sub>z</sub> mm <sup>4</sup> x10 <sup>4</sup>	W <sub>el,y</sub> =W <sub>el,z</sub> mm <sup>3</sup> x10 <sup>3</sup>	i <sub>y</sub> =i <sub>z</sub> mm x10	I <sub>u</sub> mm <sup>4</sup> x10 <sup>4</sup>	i <sub>u</sub> mm x10	I <sub>v</sub> mm <sup>4</sup> x10 <sup>4</sup>	i <sub>v</sub> mm x10	I <sub>yz</sub> mm <sup>4</sup> x10 <sup>4</sup>
L 50 x 50 x 4	3.11	50	4	7	3.89	13.59	35.36	19.21	17.52	8.97	2.46	1.52	14.22	1.91	3.73	0.98	-5.24
L 50 x 50 x 5	3.84	50	5	7/2*	4.80	14.04	35.36	19.85	17.59	10.96	3.05	1.51	17.38	1.90	4.55	0.97	-6.42
L 50 x 50 x 6	4.55	50	6	7/2*	5.69	14.45	35.36	20.44	17.71	12.84	3.61	1.50	20.34	1.89	5.34	0.97	-7.50
L 50 x 50 x 7	5.25	50	7	7/2*	6.56	14.85	35.36	21.01	17.85	14.61	4.16	1.49	23.11	1.88	6.11	0.97	-8.50
L 50 x 50 x 8	5.93	50	8	7/2*	7.41	15.24	35.36	21.55	18.01	16.28	4.68	1.48	25.69	1.86	6.88	0.96	-9.41
L 60 x 60 x 5	4.65	60	5	8/2*	5.82	16.44	42.43	23.24	21.06	19.37	4.45	1.82	30.71	2.30	8.03	1.17	-11.34
L 60 x 60 x 6	5.53	60	6	8/2*	6.91	16.88	42.43	23.87	21.15	22.79	5.29	1.82	36.14	2.29	9.44	1.17	-13.35
L 60 x 60 x 7	6.38	60	7	8/2*	7.98	17.29	42.43	24.45	21.27	26.05	6.10	1.81	41.28	2.27	10.82	1.16	-15.23
L 60 x 60 x 8	7.22	60	8	8/2*	9.03	17.69	42.43	25.02	21.41	29.15	6.89	1.80	46.14	2.26	12.16	1.16	-16.99
L 60 x 60 x 10	8.85	60	10	8/2*	11.07	18.46	42.43	26.10	21.74	34.93	8.41	1.78	55.06	2.23	14.80	1.16	-20.13
L 65 x 65 x 6	6.02	65	6	9/2*	7.53	18.04	45.96	25.51	22.83	29.19	6.21	1.97	46.27	2.48	12.11	1.27	-17.08
L 65 x 65 x 7	6.96	65	7	9/2*	8.70	18.47	45.96	26.12	22.93	33.43	7.18	1.96	52.99	2.47	13.87	1.26	-19.56
L 65 x 65 x 8	7.88	65	8	9/2*	9.85	18.88	45.96	26.70	23.06	37.49	8.13	1.95	59.38	2.46	15.60	1.26	-21.89
L 65 x 65 x 9	8.78	65	9	9/2*	10.98	19.28	45.96	27.26	23.20	41.37	9.05	1.94	65.44	2.44	17.30	1.26	-24.07
L 65 x 65 x 10	9.67	65	10	9/2*	12.09	19.66	45.96	27.81	23.36	45.08	9.94	1.93	71.19	2.43	18.98	1.25	-26.11
L 70 x 70 x 5	5.47	70	5	9/2*	6.84	18.82	49.50	26.62	24.55	31.24	6.10	2.14	49.50	2.69	12.97	1.38	-18.26
L 70 x 70 x 6	6.50	70	6	9/2*	8.13	19.28	49.50	27.27	24.61	36.88	7.27	2.13	58.50	2.68	15.27	1.37	-21.61
L 70 x 70 x 7	7.52	70	7	9/2*	9.40	19.71	49.50	27.88	24.70	42.30	8.41	2.12	67.09	2.67	17.51	1.36	-24.79
L 70 x 70 x 8	8.53	70	8	10/2*	10.67	20.06	49.50	28.37	24.72	47.27	9.46	2.10	74.89	2.65	19.64	1.36	-27.63
L 70 x 70 x 9	9.50	70	9	9/2*	11.88	20.53	49.50	29.03	24.97	52.47	10.60	2.10	83.09	2.64	21.84	1.36	-30.62
L 70 x 70 x 10	10.47	70	10	9/2*	13.09	20.91	49.50	29.58	25.13	57.24	11.66	2.09	90.52	2.63	23.96	1.35	-33.28
L 75 x 75 x 5	5.87	75	5	9/2*	7.34	20.06	53.03	28.37	26.33	38.77	7.06	2.30	61.46	2.89	16.08	1.48	-22.69
L 75 x 75 x 6	6.98	75	6	9/2*	8.73	20.53	53.03	29.03	26.38	45.83	8.41	2.29	72.71	2.89	18.94	1.47	-26.89
L 75 x 75 x 7	8.08	75	7	9/2*	10.10	20.96	53.03	29.64	26.48	52.61	9.74	2.28	83.49	2.88	21.73	1.47	-30.88
L 75 x 75 x 8	9.16	75	8	9/2*	11.45	21.37	53.03	30.23	26.60	59.13	11.03	2.27	93.80	2.86	24.46	1.46	-34.67

Other custom sizes are available upon request

\* Profiles are also available as laser welded with full penetration, non tapered, equivalent to hot rolled (r = laser seam).

# L EQUAL LEG ANGLES

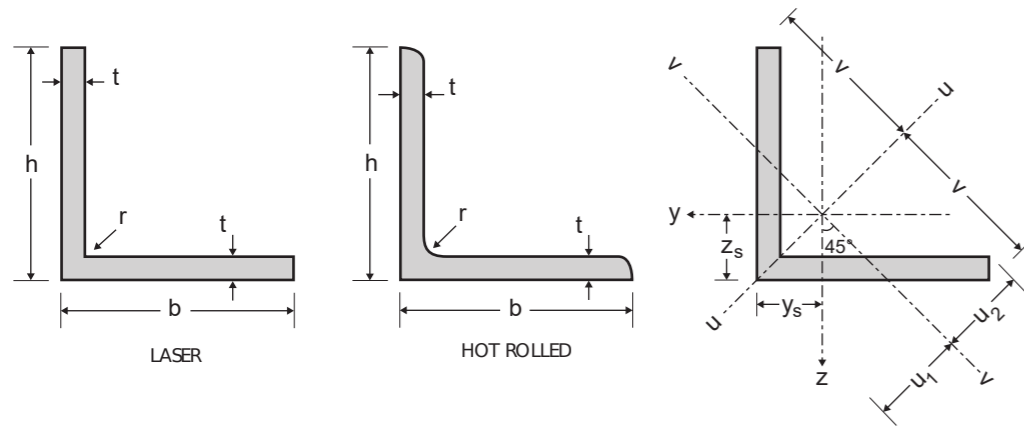

## STAINLESS STEEL

### Product Description

Dimensions: in accordance with EN 10056-1: 1998  
 Tolerances: EN 10056-2:1993.  
 Grade according to EN 10088-3: 1D  
 Surface condition: blasted and pickled

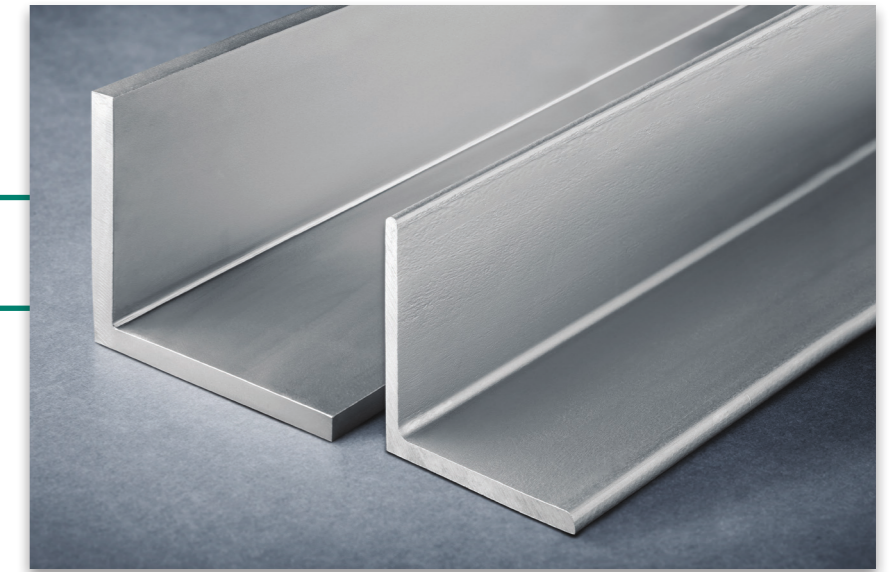

General properties						Structural properties											
Designation		Dimensions				Position of axes				Axis y-y / axis z-z			Axis u-u		Axis v-v		
	G kg/m	h=b mm	t mm	r mm	A mm <sup>2</sup> x10 <sup>2</sup>	z <sub>s</sub> =y <sub>s</sub> mm	v mm	u <sub>1</sub> mm	u <sub>2</sub> mm	I <sub>y</sub> =I <sub>z</sub> mm <sup>4</sup> x10 <sup>4</sup>	W <sub>el,y</sub> =W <sub>el,z</sub> mm <sup>3</sup> x10 <sup>3</sup>	i <sub>y</sub> =i <sub>z</sub> mm x10	I <sub>u</sub> mm <sup>4</sup> x10 <sup>4</sup>	i <sub>u</sub> mm x10	I <sub>v</sub> mm <sup>4</sup> x10 <sup>4</sup>	i <sub>v</sub> mm x10	I <sub>yz</sub> mm <sup>4</sup> x10 <sup>4</sup>
L 75 x 75 x 9	10.22	75	9	9 / 2 *	12.78	21.77	53.03	30.79	26.74	65.40	12.29	2.26	103.66	2.85	27.13	1.46	-38.26
L 75 x 75 x 10	11.27	75	10	9 / 2 *	14.09	22.16	53.03	31.35	26.89	71.43	13.52	2.25	113.08	2.83	29.77	1.45	-41.66
L 80 x 80 x 6	7.48	80	6	10 / 2 *	9.35	21.67	56.57	30.65	28.09	55.82	9.57	2.44	88.51	3.08	23.13	1.57	-32.69
L 80 x 80 x 7	8.65	80	7	10 / 2 *	10.82	22.12	56.57	31.29	28.16	64.19	11.09	2.44	101.83	3.07	26.55	1.57	-37.64
L 80 x 80 x 8	9.81	80	8	10 / 2 *	12.27	22.55	56.57	31.89	28.26	72.25	12.58	2.43	114.61	3.06	29.88	1.56	-42.36
L 80 x 80 x 9	10.96	80	9	10 / 2 *	13.70	22.96	56.57	32.47	28.39	80.01	14.03	2.42	126.87	3.04	33.16	1.56	-46.86
L 80 x 80 x 10	12.09	80	10	10 / 2 *	15.11	23.36	56.57	33.04	28.53	87.50	15.45	2.41	138.63	3.03	36.38	1.55	-51.12
L 90 x 90 x 6	8.44	90	6	10 / 2 *	10.55	24.16	63.64	34.17	31.64	80.72	12.26	2.77	128.08	3.48	33.37	1.78	-47.35
L 90 x 90 x 7	9.79	90	7	11 / 2 *	12.24	24.52	63.64	34.68	31.63	92.55	14.13	2.75	146.80	3.46	38.29	1.77	-54.25
L 90 x 90 x 8	11.11	90	8	11 / 2 *	13.89	24.96	63.64	35.31	31.71	104.38	16.05	2.74	165.63	3.45	43.14	1.76	-61.24
L 90 x 90 x 9	12.42	90	9	11 / 2 *	15.52	25.39	63.64	35.90	31.82	115.83	17.93	2.73	183.78	3.44	47.89	1.76	-67.94
L 90 x 90 x 10	13.70	90	10	11 / 2 *	17.13	25.80	63.64	36.48	31.95	126.91	19.77	2.72	201.27	3.43	52.56	1.75	-74.36
L 100 x 100 x 6	9.44	100	6	12 / 2 *	11.79	26.42	70.71	37.36	35.10	111.05	15.09	3.07	175.90	3.86	46.21	1.98	-64.84
L 100 x 100 x 7	10.93	100	7	12 / 2 *	13.66	26.91	70.71	38.06	35.12	128.20	17.54	3.06	203.29	3.86	53.11	1.97	-75.09
L 100 x 100 x 8	12.41	100	8	12 / 2 *	15.51	27.37	70.71	38.70	35.18	144.84	19.94	3.06	229.81	3.85	59.87	1.96	-84.97
L 100 x 100 x 9	13.88	100	9	12 / 2 *	17.34	27.80	70.71	39.32	35.27	160.99	22.30	3.05	255.49	3.84	66.50	1.96	-94.50
L 100 x 100 x 10	15.32	100	10	12 / 2 *	19.15	28.22	70.71	39.92	35.38	176.68	24.62	3.04	280.34	3.83	73.01	1.95	-103.66
L 100 x 100 x 12	18.17	100	12	12 / 2 *	22.71	29.03	70.71	41.06	35.65	206.69	29.12	3.02	327.62	3.80	85.76	1.94	-120.93
L 110 x 110 x 6	10.40	110	6	12 / 2 *	12.99	28.91	77.78	40.88	38.66	149.46	18.43	3.39	236.86	4.27	62.07	2.19	-87.40
L 110 x 110 x 7	12.05	110	7	12 / 2 *	15.06	29.40	77.78	41.58	38.67	172.69	21.43	3.39	273.98	4.26	71.40	2.18	-101.29
L 110 x 110 x 8	13.69	110	8	12 / 2 *	17.11	29.86	77.78	42.23	38.73	195.29	24.37	3.38	310.03	4.26	80.55	2.17	-114.74
L 110 x 110 x 9	15.32	110	9	12 / 2 *	19.14	30.30	77.78	42.85	38.81	217.29	27.26	3.37	345.05	4.25	89.53	2.16	-127.76
L 110 x 110 x 10	16.95	110	10	13 / 2 *	21.18	30.64	77.78	43.34	38.82	237.98	29.99	3.35	377.70	4.22	98.26	2.15	-139.72
L 110 x 110 x 11	18.54	110	11	13 / 2 *	23.17	31.06	77.78	43.93	38.94	258.82	32.79	3.34	410.72	4.21	106.93	2.15	-151.90
L 110 x 110 x 12	20.11	110	12	13 / 2 *	25.14	31.47	77.78	44.50	39.07	279.11	35.54	3.33	442.75	4.20	115.47	2.14	-163.64

Other custom sizes are available upon request

\* Profiles are also available as laser welded with full penetration, non tapered, equivalent to hot rolled (r = laser seam).

# L EQUAL LEG ANGLES

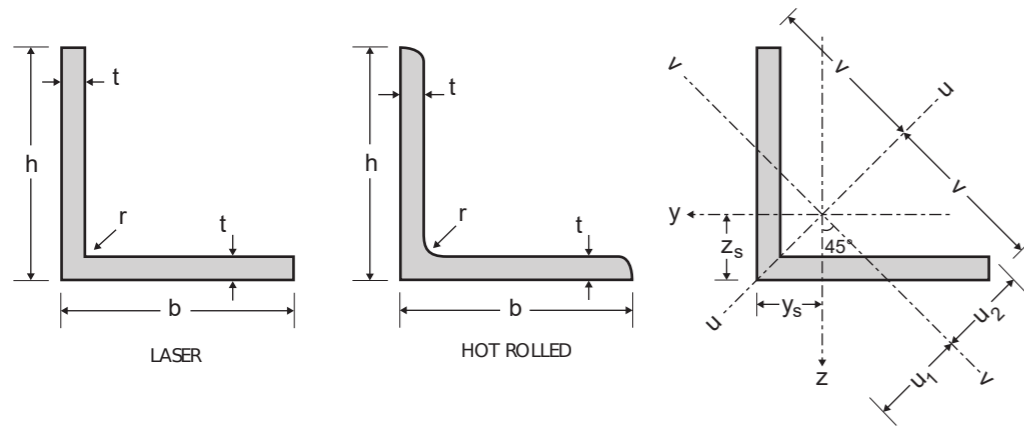

## STAINLESS STEEL

### Product Description

Dimensions: in accordance with EN 10056-1: 1998  
 Tolerances: EN 10056-2:1993.  
 Grade according to EN 10088-3: 1D  
 Surface condition: blasted and pickled

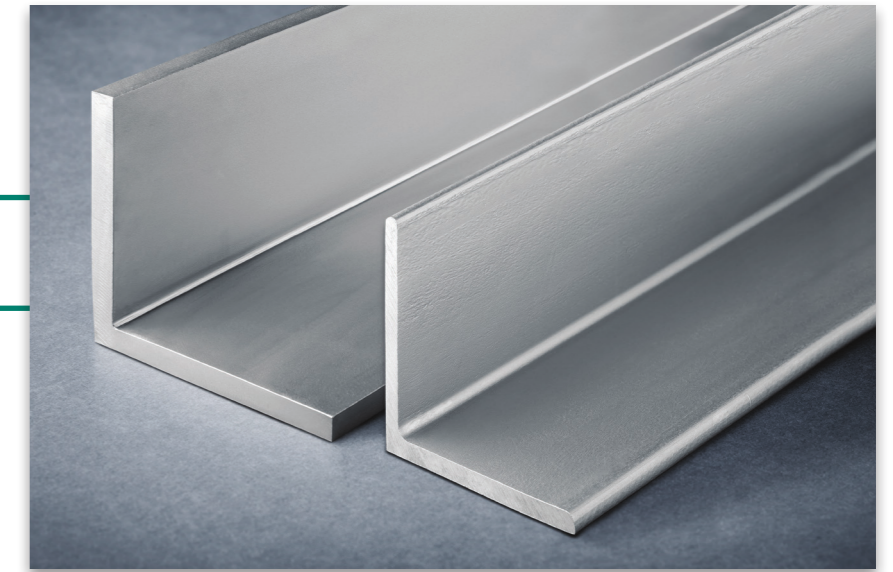

General properties						Structural properties											
Designation		Dimensions				Position of axes				Axis y-y / axis z-z			Axis u-u		Axis v-v		
	G kg/m	h=b mm	t mm	r mm	A mm <sup>2</sup> x10 <sup>2</sup>	z <sub>s</sub> =y <sub>s</sub> mm	v mm	u <sub>1</sub> mm	u <sub>2</sub> mm	I <sub>y</sub> =I <sub>z</sub> mm <sup>4</sup> x10 <sup>4</sup>	W <sub>el,y</sub> =W <sub>el,z</sub> mm <sup>3</sup> x10 <sup>3</sup>	i <sub>y</sub> =i <sub>z</sub> mm x10	I <sub>u</sub> mm <sup>4</sup> x10 <sup>4</sup>	i <sub>u</sub> mm x10	I <sub>v</sub> mm <sup>4</sup> x10 <sup>4</sup>	i <sub>v</sub> mm x10	I <sub>yz</sub> mm <sup>4</sup> x10 <sup>4</sup>
L 120 x 120 x 7	13.19	120	7	13 / 2 *	16.49	31.78	84.85	44.94	42.17	225.58	25.57	3.70	357.71	4.66	93.45	2.38	-132.13
L 120 x 120 x 8	14.99	120	8	13 / 2 *	18.74	32.25	84.85	45.61	42.21	255.43	29.11	3.69	405.38	4.65	105.48	2.37	-149.95
L 120 x 120 x 9	16.78	120	9	13 / 2 *	20.97	32.70	84.85	46.25	42.27	284.54	32.59	3.68	451.79	4.64	117.29	2.36	-167.25
L 120 x 120 x 10	18.55	120	10	13 / 2 *	23.18	33.14	84.85	46.86	42.37	312.94	36.03	3.67	496.96	4.63	128.91	2.36	-184.03
L 120 x 120 x 11	20.30	120	11	13 / 2 *	25.37	33.56	84.85	47.46	42.48	340.64	39.41	3.66	540.93	4.62	140.35	2.35	-200.29
L 120 x 120 x 12	22.03	120	12	13 / 2 *	27.54	33.97	84.85	48.03	42.61	367.67	42.73	3.65	583.70	4.60	151.63	2.35	-216.04
L 120 x 120 x 13	23.75	120	13	13 / 2 *	29.69	34.37	84.85	48.60	42.75	394.04	46.01	3.64	625.31	4.59	162.77	2.34	-231.27
L 120 x 120 x 14	25.46	120	14	13 / 2 *	31.82	34.76	84.85	49.16	42.90	419.77	49.25	3.63	665.77	4.57	173.78	2.34	-246.00
L 120 x 120 x 15	27.15	120	15	13 / 2 *	33.93	35.15	84.85	49.71	43.06	444.89	52.43	3.62	705.10	4.56	184.67	2.33	-260.21
L 120 x 120 x 16	28.82	120	16	13 / 2 *	36.02	35.53	84.85	50.25	43.22	469.40	55.57	3.61	743.33	4.54	195.48	2.33	-273.93
L 130 x 130 x 8	16.30	130	8	14 / 2 *	20.37	34.64	91.92	48.98	45.70	326.74	34.26	4.00	518.35	5.04	135.13	2.58	-191.61
L 130 x 130 x 9	18.24	130	9	14 / 2 *	22.80	35.10	91.92	49.64	45.75	364.36	38.39	4.00	578.39	5.04	150.33	2.57	-214.03
L 130 x 130 x 10	20.17	130	10	14 / 2 *	25.21	35.55	91.92	50.27	45.83	401.12	42.47	3.99	636.97	5.03	165.28	2.56	-235.84
L 130 x 130 x 11	22.08	130	11	14 / 2 *	27.60	35.98	91.92	50.88	45.93	437.05	46.48	3.98	694.10	5.01	180.01	2.55	-257.05
L 130 x 130 x 12	23.98	130	12	14 / 2 *	29.97	36.39	91.92	51.47	46.04	472.17	50.44	3.97	749.82	5.00	194.53	2.55	-277.65
L 130 x 130 x 13	25.86	130	13	14 / 2 *	32.32	36.80	91.92	52.05	46.17	506.50	54.35	3.96	804.14	4.99	208.86	2.54	-297.64
L 130 x 130 x 14	27.72	130	14	14 / 2 *	34.65	37.20	91.92	52.61	46.31	540.06	58.20	3.95	857.09	4.97	223.03	2.54	-317.03
L 130 x 130 x 15	29.57	130	15	14 / 2 *	36.96	37.60	91.92	53.17	46.46	572.87	62.00	3.94	908.70	4.96	237.05	2.53	-335.82
L 130 x 130 x 16	31.40	130	16	14 / 2 *	39.25	37.99	91.92	53.72	46.62	604.96	65.75	3.93	958.98	4.94	250.93	2.53	-354.02
L 140 x 140 x 9	19.71	140	9	15 / 2 *	24.63	37.49	98.99	53.02	49.23	457.79	44.66	4.31	726.49	5.43	189.10	2.77	-268.69
L 140 x 140 x 10	21.79	140	10	15 / 2 *	27.24	37.95	98.99	53.67	49.29	504.43	49.43	4.30	800.88	5.42	207.98	2.76	-296.45
L 140 x 140 x 11	23.87	140	11	15 / 2 *	29.83	38.39	98.99	54.29	49.38	550.09	54.14	4.29	873.59	5.41	226.59	2.76	-323.50
L 140 x 140 x 12	25.92	140	12	15 / 2 *	32.40	38.81	98.99	54.89	49.48	594.78	58.78	4.28	944.63	5.40	244.94	2.75	-349.85
L 140 x 140 x 13	27.96	140	13	15 / 2 *	34.95	39.23	98.99	55.48	49.60	638.54	63.37	4.27	1014.03	5.39	263.05	2.74	-375.49
L 140 x 140 x 14	29.99	140	14	15 / 2 *	37.48	39.64	98.99	56.06	49.73	681.38	67.89	4.26	1081.81	5.37	280.95	2.74	-400.43
L 140 x 140 x 15	31.99	140	15	15 / 2 *	39.99	40.04	98.99	56.62	49.87	723.33	72.36	4.25	1148.00	5.36	298.66	2.73	-424.67
L 140 x 140 x 16	33.99	140	16	15 / 2 *	42.48	40.43	98.99	57.18	50.02	764.41	76.77	4.24	1212.63	5.34	316.19	2.73	-448.22

Other custom sizes are available upon request

\* Profiles are also available as laser welded with full penetration, non tapered, equivalent to hot rolled (r = laser seam).

# L EQUAL LEG ANGLES

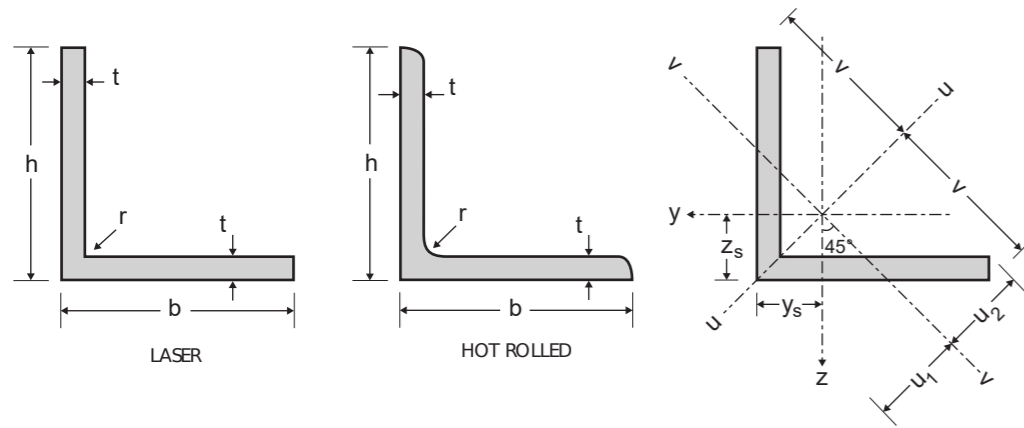

## STAINLESS STEEL

### Product Description

Dimensions: in accordance with EN 10056-1: 1998  
 Tolerances: EN 10056-2:1993.  
 Grade according to EN 10088-3: 1D  
 Surface condition: blasted and pickled

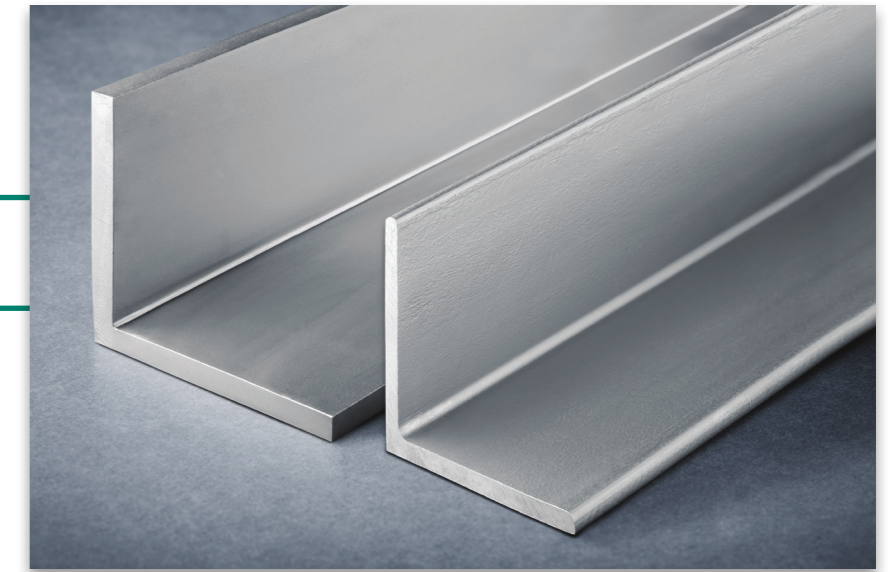

General properties						Structural properties											
Designation		Dimensions				Position of axes				Axis y-y / axis z-z			Axis u-u		Axis v-v		
	G kg/m	h=b mm	t mm	r mm	A mm <sup>2</sup> x10 <sup>2</sup>	z <sub>s</sub> =y <sub>s</sub> mm	v mm	u <sub>1</sub> mm	u <sub>2</sub> mm	I <sub>y</sub> =I <sub>z</sub> mm <sup>4</sup> x10 <sup>4</sup>	W <sub>el,y</sub> =W <sub>el,z</sub> mm <sup>3</sup> x10 <sup>3</sup>	i <sub>y</sub> =i <sub>z</sub> mm x10	I <sub>u</sub> mm <sup>4</sup> x10 <sup>4</sup>	i <sub>u</sub> mm x10	I <sub>v</sub> mm <sup>4</sup> x10 <sup>4</sup>	i <sub>v</sub> mm x10	I <sub>yz</sub> mm <sup>4</sup> x10 <sup>4</sup>
L 150 x 150 x 10	23.42	150	10	16 / 2 *	29.27	40.34	106.07	57.05	52.77	624.04	56.91	4.62	990.54	5.82	257.54	2.97	-366.50
L 150 x 150 x 12	27.87	150	12	16 / 2 *	34.83	41.23	106.07	58.31	52.93	736.91	67.75	4.60	1170.35	5.80	303.47	2.95	-433.44
L 150 x 150 x 13	30.07	150	13	16 / 2 *	37.58	41.65	106.07	58.90	53.04	791.69	73.07	4.59	1257.39	5.78	325.99	2.95	-465.70
L 150 x 150 x 14	32.25	150	14	16 / 2 *	40.31	42.07	106.07	59.49	53.16	845.39	78.33	4.58	1342.54	5.77	348.25	2.94	-497.15
L 150 x 150 x 15	34.42	150	15	16 / 2 *	43.02	42.47	106.07	60.07	53.29	898.05	83.52	4.57	1425.84	5.76	370.26	2.93	-527.79
L 150 x 150 x 16	36.57	150	16	16 / 2 *	45.71	42.87	106.07	60.63	53.43	949.68	88.65	4.56	1507.32	5.74	392.05	2.93	-557.63
L 150 x 150 x 18	40.83	150	18	16 / 2 *	51.03	43.66	106.07	61.74	53.74	1049.96	98.74	4.54	1664.90	5.71	435.03	2.92	-614.93
L 150 x 150 x 20	45.02	150	20	16 / 2 *	56.27	44.43	106.07	62.83	54.07	1146.43	108.59	4.51	1815.50	5.68	477.36	2.91	-669.07
L 160 x 160 x 15	36.85	160	15	2 +	46.06	44.90	113.14	63.50	56.72	1098.83	95.47	4.88	1745.03	6.16	452.63	3.13	-646.20
L 160 x 160 x 16	39.16	160	16	2 +	48.95	45.31	113.14	64.08	56.85	1162.70	101.38	4.87	1846.06	6.14	479.34	3.13	-683.36
L 160 x 160 x 18	43.74	160	18	2 +	54.67	46.10	113.14	65.20	57.14	1286.96	112.99	4.85	2041.90	6.11	532.01	3.12	-754.95
L 160 x 160 x 20	48.25	160	20	2 +	60.31	46.88	113.14	66.30	57.46	1406.75	124.36	4.83	2229.67	6.08	583.84	3.11	-822.92
L 180 x 180 x 13	36.37	180	13	2 +	45.46	48.97	127.28	69.26	63.49	1396.09	106.55	5.54	2217.95	6.99	574.23	3.55	-821.86
L 180 x 180 x 15	41.68	180	15	2 +	52.10	49.82	127.28	70.46	63.70	1588.55	122.03	5.52	2524.07	6.96	653.04	3.54	-935.52
L 180 x 180 x 16	44.31	180	16	2 +	55.39	50.24	127.28	71.05	63.82	1682.43	129.65	5.51	2673.03	6.95	691.83	3.53	-990.60
L 180 x 180 x 18	49.53	180	18	2 +	61.91	51.04	127.28	72.19	64.09	1865.60	144.67	5.49	2962.89	6.92	768.32	3.52	-1097.29
L 180 x 180 x 20	54.68	180	20	2 +	68.35	51.83	127.28	73.30	64.39	2042.87	159.39	5.47	3242.24	6.89	843.51	3.51	-1199.36
L 200 x 200 x 13	40.53	200	13	2 +	50.66	53.96	141.42	76.31	70.57	1939.06	132.78	6.19	3082.36	7.80	795.77	3.96	-1143.30
L 200 x 200 x 15	46.48	200	15	2 +	58.10	54.82	141.42	77.52	70.78	2209.25	152.17	6.17	3512.66	7.78	905.85	3.95	-1303.40
L 200 x 200 x 16	49.43	200	16	2 +	61.79	55.23	141.42	78.11	70.90	2341.35	161.73	6.16	3722.65	7.76	960.06	3.94	-1381.29
L 200 x 200 x 18	55.29	200	18	2 +	69.11	56.04	141.42	79.26	71.17	2599.74	180.59	6.13	4132.50	7.73	1066.98	3.93	-1532.76
L 200 x 200 x 20	61.08	200	20	2 +	76.35	56.83	141.42	80.38	71.46	2850.58	199.11	6.11	4529.08	7.70	1172.08	3.92	-1678.50
L 250 x 250 x 13	50.93	250	13	2 +	63.66	66.44	176.78	93.96	88.28	3872.91	210.99	7.80	6163.21	9.84	1582.61	4.99	-2290.30
L 250 x 250 x 15	58.48	250	15	2 +	73.10	67.30	176.78	95.18	88.47	4423.16	242.10	7.78	7041.15	9.81	1805.18	4.97	-2617.99
L 250 x 250 x 18	69.69	250	18	2 +	87.11	68.54	176.78	96.93	88.85	5224.24	287.90	7.74	8316.73	9.77	2131.74	4.95	-3092.50

Other custom sizes are available upon request

Profiles are \* also available or +only available as laser welded with full penetration, non tapered, equivalent to hot rolled (r =laser seam).

# L EQUAL LEG ANGLES

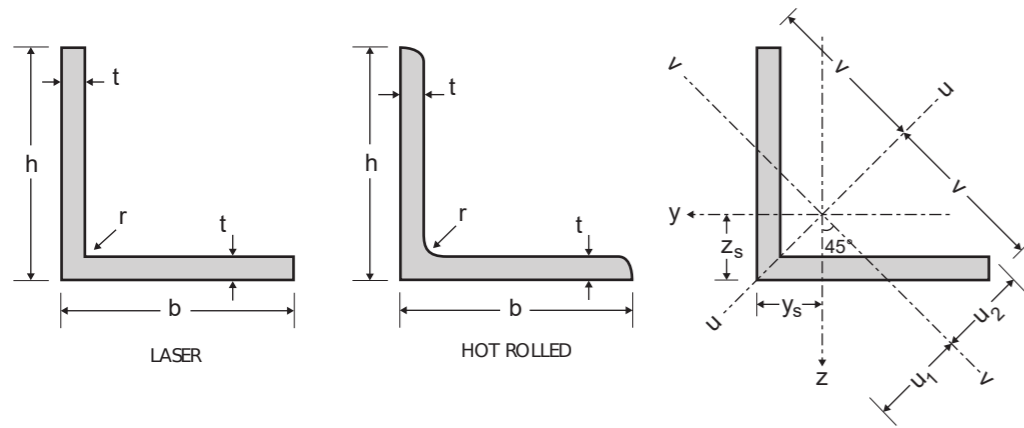

## STAINLESS STEEL

### Product Description

Dimensions: in accordance with EN 10056-1: 1998  
 Tolerances: EN 10056-2:1993.  
 Grade according to EN 10088-3: 1D  
 Surface condition: blasted and pickled

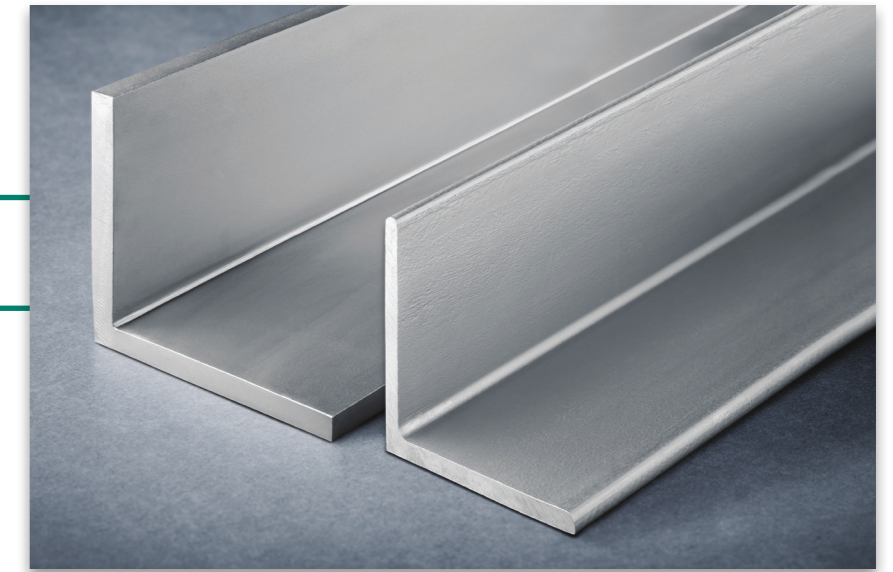

General properties						Structural properties											
Designation		Dimensions				Position of axes				Axis y-y / axis z-z			Axis u-u		Axis v-v		
	G kg/m	h=b mm	t mm	r mm	A mm <sup>2</sup> x10 <sup>2</sup>	z <sub>s</sub> =y <sub>s</sub> mm	v mm	u <sub>1</sub> mm	u <sub>2</sub> mm	I <sub>y</sub> =I <sub>z</sub> mm <sup>4</sup> x10 <sup>4</sup>	W <sub>el,y</sub> =W <sub>el,z</sub> mm <sup>3</sup> x10 <sup>3</sup>	i <sub>y</sub> =i <sub>z</sub> mm x10	I <sub>u</sub> mm <sup>4</sup> x10 <sup>4</sup>	i <sub>u</sub> mm x10	I <sub>v</sub> mm <sup>4</sup> x10 <sup>4</sup>	i <sub>v</sub> mm x10	I <sub>yz</sub> mm <sup>4</sup> x10 <sup>4</sup>
L 250 x 250 x 20	77.08	250	20	2 +	96.35	69.34	176.78	98.06	89.13	5742.57	317.86	7.72	9140.12	9.74	2345.02	4.93	-3397.55
L 300 x 300 x 13	61.33	300	13	2 +	76.66	78.93	212.13	111.63	105.97	6792.72	307.27	9.41	10818.12	11.88	2767.32	6.01	-4025.40
L 300 x 300 x 15	70.48	300	15	2 +	88.10	79.80	212.13	112.85	106.16	7770.54	352.88	9.39	12379.71	11.85	3161.37	5.99	-4609.17
L 300 x 300 x 16	75.03	300	16	2 +	93.79	80.22	212.13	113.44	106.28	8252.16	375.47	9.38	13148.28	11.84	3356.04	5.98	-4896.12
L 300 x 300 x 18	84.09	300	18	2 +	105.11	81.04	212.13	114.60	106.53	9201.10	420.21	9.36	14661.28	11.81	3740.92	5.97	-5460.18
L 300 x 300 x 20	93.08	300	20	2 +	116.35	81.84	212.13	115.74	106.81	10131.30	464.40	9.33	16142.46	11.78	4120.14	5.95	-6011.16

Other custom sizes are available upon request

+Prof les are only available as laser welded with full penetration, non tapered, equivalent to hot rolled (r = laser seam).