

MAYWOOD  STUDIO

# BELLE EPOQUE QUILT



**Belle Epoque Quilt by Maywood Studio**  
featuring the Belle Epoque Collection

69 x 69

#madewithmaywood  
maywoodstudio.com



# MAYWOOD STUDIO



Fabric 1  
9875-N  
Cut for  
B, C, F, G, J, K



Fabric 2  
9876-SW  
Cut for  
A, B, C



Fabric 3  
9874-E  
Cut for  
D, E, F, G



Fabric 4  
9870-E  
Cut for  
H, I, J, K

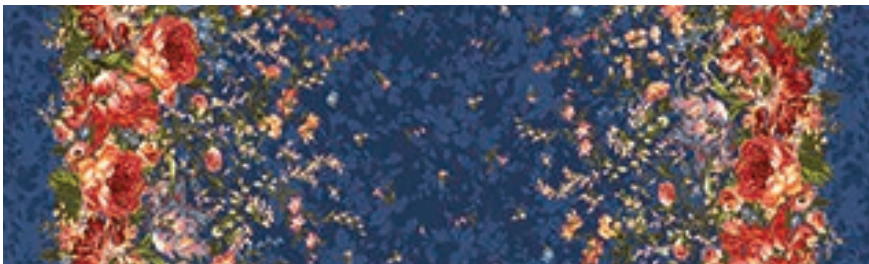

Fabric 5  
9872-N



Binding  
9878-N

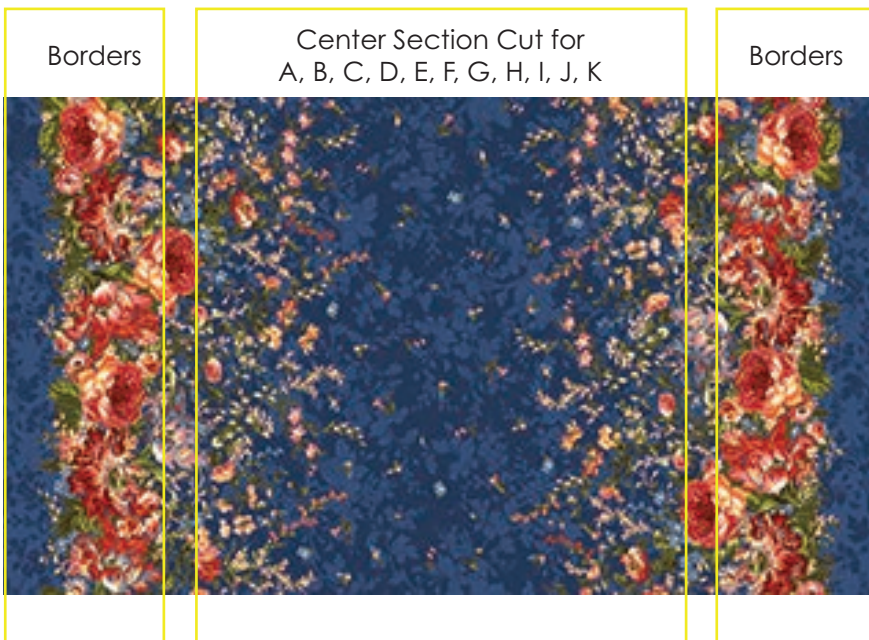

## Note:

Fabric 5 is a double border. The borders for the Belle Epoque quilt are cut LOF (along the length of the fabric.) Cut the borders first.

Then use the center of the fabric that is left over to cut the A-K pieces. These are also cut along the LOF (length of the fabric.)

We recommend cutting the center fabric in half into two 72" pieces and then folding each in half lengthwise, into one yard sections.

## Fabric Requirements

Fabric 1	9875-N	7/8 yard
Fabric 2	9876-SW	1/4 yard
Fabric 3	9874-E	5/8 yard
Fabric 4	9870-E	1 yard
Fabric 5	9872-N	4-1/4 yards
Binding	9878-N	5/8 yard
Backing	your choice	4 yards

Finished Size 69" x 69"

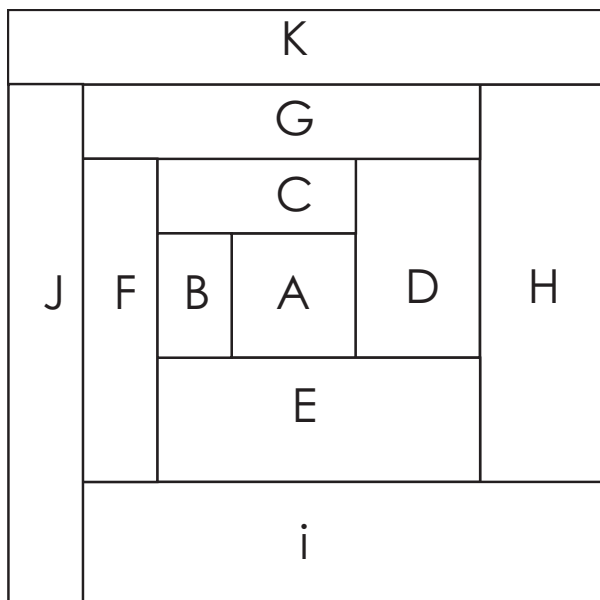

Measurements:

A	2.5 x 2.5" squares
B	1.5 x 2.5" rectangles
C	1.5 x 3.5" rectangles
D	2.5 x 3.5" rectangles
E	2.5 x 5.5" rectangles
F	1.5 x 5.5" rectangles
G	1.5 x 6.5" rectangles
H	2.5 x 6.5" rectangles
I	2.5 x 8.5" rectangles
J	1.5 x 8.5" rectangles
K	1.5 x 9.5" rectangles

WOF - Width of Fabric  
 LOF - Length of Fabric  
 RST - Right Sides Together  
 HST - Half Square Triangle

## Cutting

Fabric 1 Blue Damask

Cut (19) 1.5" x WOF strips. Subcut starting with K and end with B, which will use the leftover strips.

B (20) 1.5 x 2.5" rectangles (from leftover)

C (20) 1.5 x 3.5" rectangles (2 strips)

F (20) 1.5 x 5.5" rectangles (3 strips)

G (20) 1.5 x 6.5" rectangles (4 strips)

J (20) 1.5 x 8.5" rectangles (5 strips)

K (20) 1.5 x 9.5" rectangles (5 strips)

Fabric 2 White small tossed floral

Cut (2) 2.5 x WOF strips. Subcut into:

A (24) 2.5 x 2.5" squares

Cut (2) 1.5 x WOF strips. Subcut into:

B (12) 1.5 x 2.5" rectangles

C (12) 1.5 x 3.5" rectangles (use left over from B)

Fabric 3 White plaid floral

Cut (6) 2.5" x WOF strips. Subcut into:

D (24) 2.5 x 3.5" rectangles

E (24) 2.5 x 5.5" rectangles

Cut (4) 1.5 x WOF strips. Subcut into:

F (12) 1.5 x 5.5" rectangles

G (12) 1.5 x 6.5" rectangles

Fabric 4: White large floral

Cut (10) 2.5" x WOF strips. Subcut into:

H (24) 2.5 x 6.5" rectangles (4 strips)

I (24) 2.5 x 8.5" rectangles (6 strips)

Cut (6) 1.5 x WOF strips. Subcut into:

J (12) 1.5 x 8.5" rectangles

K (12) 1.5 x 9.5" rectangles

Fabric 5: Blue double border. Cut outer borders first

Cut (2) 8.5" x LOF strips from the outside sections of the double border. Cut each in half for (4) 76" border strips.

After the borders are cut, use the center to cut the following pieces LOF.

A (12) 2.5 x 2.5" squares

B (4) 1.5 x 2.5" rectangles

C (4) 1.5 x 3.5" rectangles

D (12) 2.5 x 3.5" rectangles

E (12) 2.5 x 5.5" rectangles

F (4) 1.5 x 5.5" rectangles

G (4) 1.5 x 6.5" rectangles

H (12) 2.5 x 6.5" rectangles

I (12) 2.5 x 8.5" rectangles

J (4) 1.5 x 8.5" rectangles

K (4) 1.5 x 9.5" rectangles

Binding: Cut (8) 2.5" x WOF strips

## Belle Epoque Quilt Instructions

Please read all instructions before you begin. Seam allowance is 1/4" unless otherwise stated. Fabric will be abbreviated to 'F'. For example, F11 refers to Fabric 11. The Log cabin blocks are worked clockwise.

Blocks: press away from center. Chain-piecing encouraged.

### Log Cabin Block 1

Gather the following pieces:

Fabric 1: B, C, F, G, J, K

Fabric 2: A

Fabric 3: D, E

Fabric 4: H, I

1. Sew a F1-B rectangle to a F2-A center square.

2. Sew a F1-C rectangle to the step 1 unit.

3. Sew a F3-D rectangle to the step 2 unit.

4. Sew a F3-E rectangle to the step 3 unit.

5. Sew a F1-F rectangle to the step 4 unit.

6. Sew a F1-G rectangle to the step 5 unit.

7. Sew a F4-H rectangle to the step 6 unit.

8. Sew a F4-I rectangle to the step 7 unit.

9. Sew a F1-J rectangle to the step 8 unit.

10. Sew a F1-K rectangle to the step 9 unit.

Block 1 is 9-1/2 x 9-1/2" unfinished. Make 20.



Step 1-2

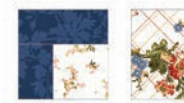

Step 3



Step 4



Step 5



Step 6



Step 7



Step 8



Step 9

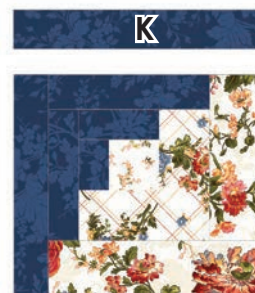

Step 10



**Block 1**  
9-1/2 x 9-1/2"  
make 20

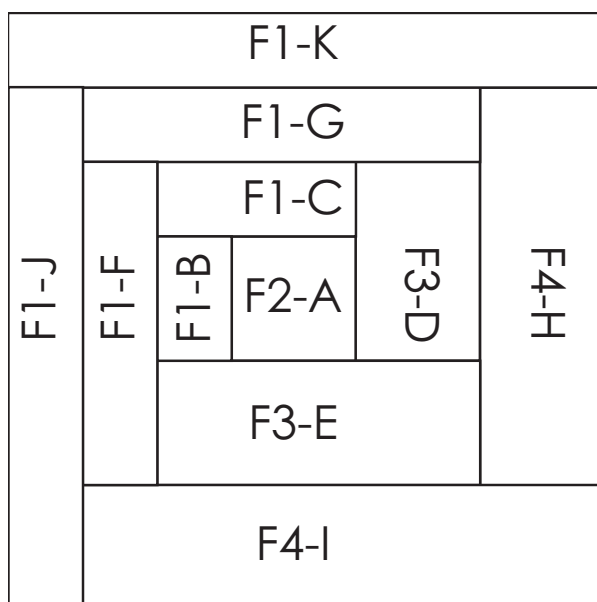

## Log Cabin Block 2

Gather the following pieces:

Fabric 2: B, C

Fabric 3: F, G

Fabric 4: J, K

Fabric 5: A, D, E, H, I



1. Sew a F2-B rectangle to a F5-A center square.

2. Sew a F2-C rectangle to the step 1 unit.

3. Sew a F5-D rectangle to the step 2 unit.

4. Sew a F5-E rectangle to the step 3 unit.

5. Sew a F3-F rectangle to the step 4 unit.

6. Sew a F3-G rectangle to the step 5 unit.

7. Sew a F5-H rectangle to the step 6 unit.

8. Sew a F5-I rectangle to the step 7 unit.

9. Sew a F4-J rectangle to the step 8 unit.

10. Sew a F4-K rectangle to the step 9 unit.

Block 2 is 9-1/2 x 9-1/2" unfinished. Make 12.

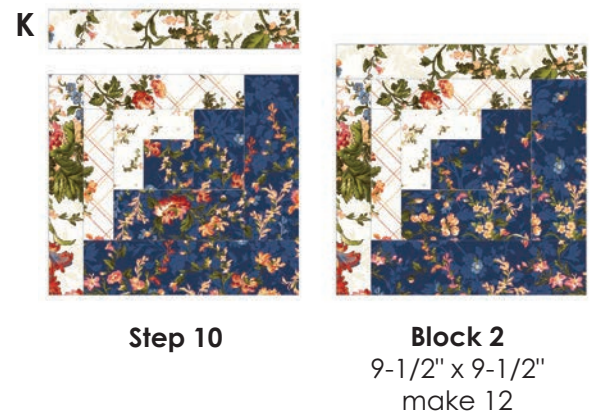
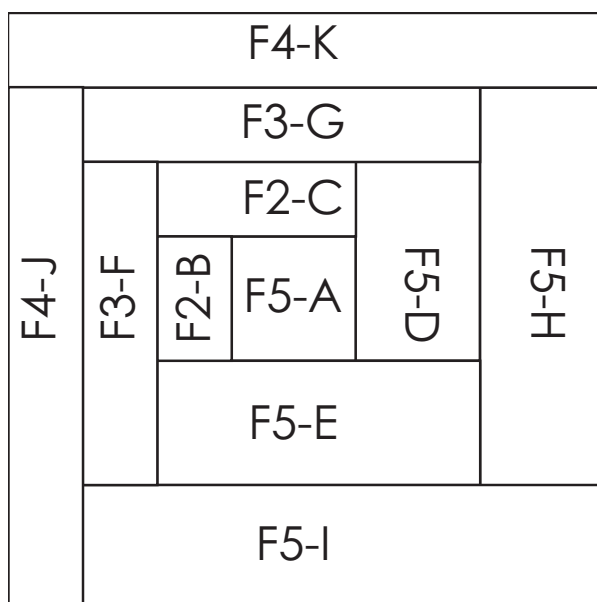

## Log Cabin Block 3

Gather the following pieces:

Fabric 2: A

Fabric 3: D, E

Fabric 4: H, I

Fabric 5: B, C, F, G, J, K

1. Sew a F5-B rectangle to a F2-A center square.
  2. Sew a F5-C rectangle to the step 1 unit.
  3. Sew a F3-D rectangle to the step 2 unit.
  4. Sew a F3-E rectangle to the step 3 unit.
  5. Sew a F5-F rectangle to the step 4 unit.
  6. Sew a F5-G rectangle to the step 5 unit.
  7. Sew a F4-H rectangle to the step 6 unit.
  8. Sew a F4-I rectangle to the step 7 unit.
  9. Sew a F5-J rectangle to the step 8 unit.
  10. Sew a F5-K rectangle to the step 9 unit.
- Block 3 is 9-1/2 x 9-1/2" unfinished. Make 4.

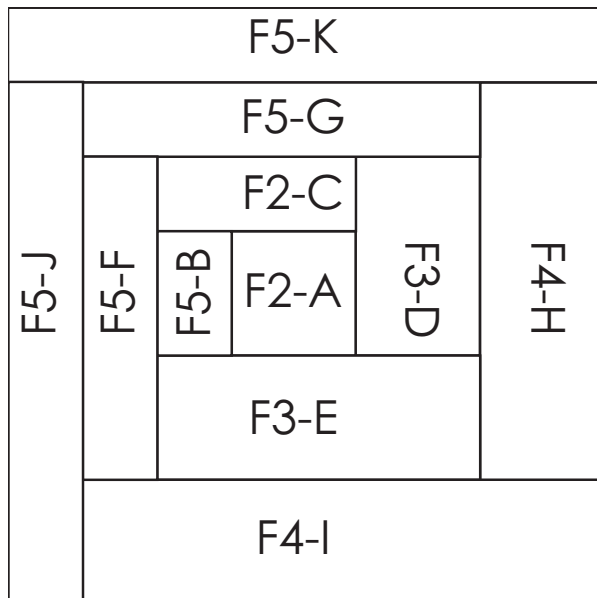

## Assemble the rows

1. Lay out the quilt blocks for each row as illustrated below. Rotate the blocks as shown.
2. Sew the blocks together into rows. Follow pressing arrows below.
3. Sew row to row (see quilt top diagram on p.8) Press seams open.

### Rows 1 and 6

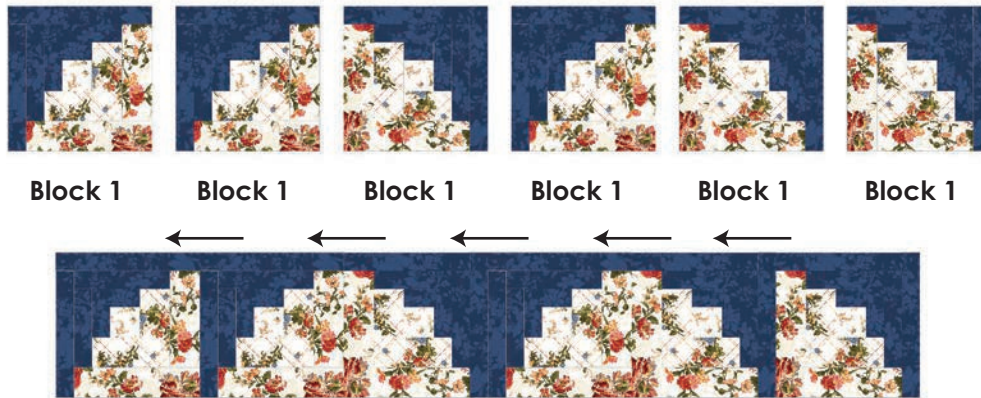

Make 2  
9.5" x 54.5"

---

### Rows 2 and 5

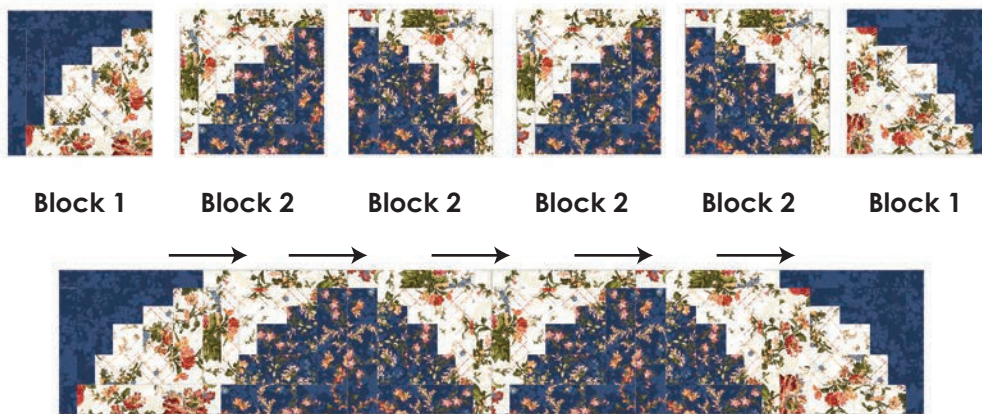

Make 2  
9.5" x 54.5"

---

### Rows 3 and 4

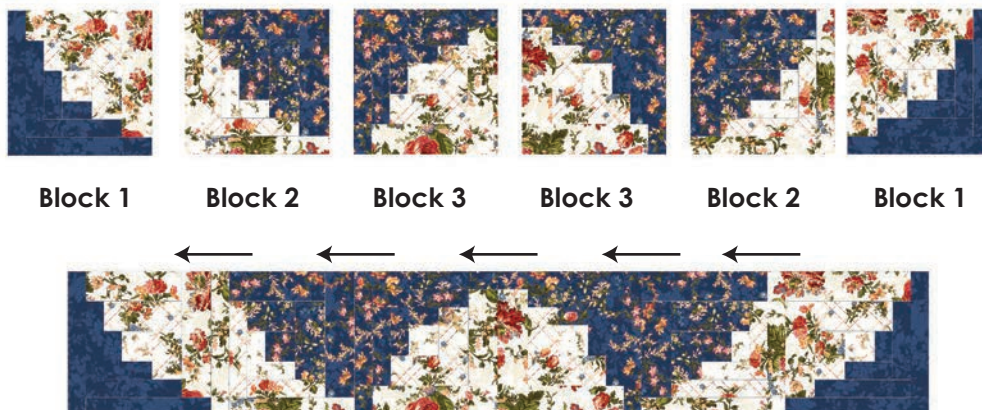

Make 2  
9.5" x 54.5"

## Finish the Quilt

NOTE: Make sure to sew the borders to the quilt top as illustrated below: the floral sections face away from the center and the blue sections are sewn to the quilt top.

1. Sew a Fabric 5 border strip to the top and bottom of the quilt top, making sure to stop and start 1/4" away from each end of the quilt top. To miter each corner, fold the quilt top on a diagonal, wrong sides together. This should line up the strips from adjacent sides.
2. Starting at the sewn seam, draw a 45° line to the edge of the fabric. Sew on that line. Trim the excess fabric leaving a 1/4" seam. Repeat on remaining corners.

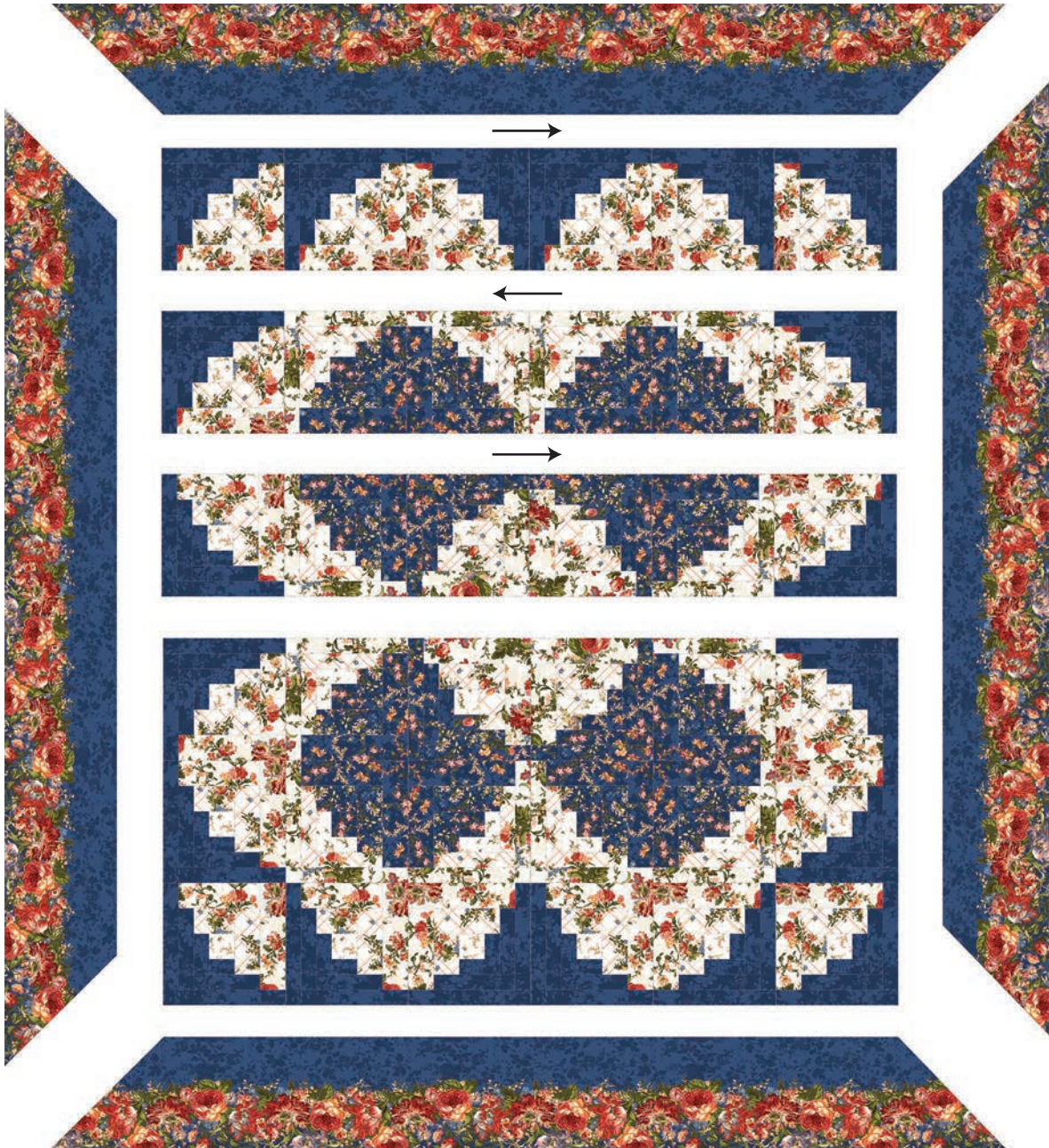

3. Layer the backing (wrong side up), batting and quilt top (right side up). Baste layers to secure. Quilt as desired. Trim the excess backing and batting.

4. Sew the binding strips together into one continuous strip. Press in half length-wise. Sew the binding to the quilt top with a 3/8" seam allowance, mitering the corners. Turn the binding to the back side of the quilt and stitch down by hand with matching thread.