

Read all instructions BEFORE assembly and USE of product.  
**KEEP INSTRUCTIONS FOR FUTURE USE.** Prior to using the product, check that the product and all parts were not damaged during delivery. Use from birth until infant begins to push up on hands and knees, can roll over, or has reached 20 lbs (9.1 kg), whichever comes first.

B A B Y  D E L I G H T ®

# Beside Me™ Wink

Bedside Sleeper and Bassinet

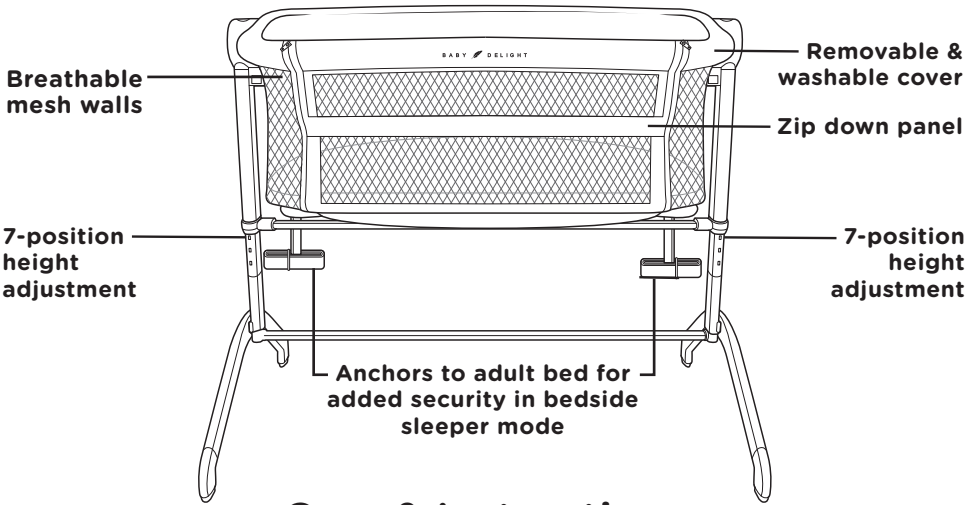

## Care & Instructions

### Contents

**Check** that you have all the parts for this model **BEFORE** assembling your product. If any parts are missing, call Customer Service.

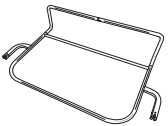

Middle support frame (2pcs)



Sleeper frame

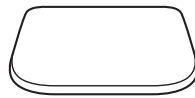

Mattress and waterproof sheet



Anchors



Bottom support bar



Middle support bar

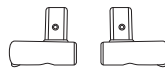

Middle support bar knuckles

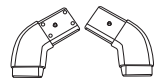

Front and back feet

BD06120, BD05080

©2020 Baby Delight, Inc. 1-401-333-6800 [www.babydelight.com](http://www.babydelight.com)

MADE IN CHINA

# WARNING

**FAILURE TO FOLLOW THESE WARNINGS AND THE INSTRUCTIONS COULD RESULT IN SERIOUS INJURY OR DEATH. DO NOT USE THIS PRODUCT IF YOU CANNOT EXACTLY FOLLOW THE INSTRUCTIONS THAT COME WITH IT. THIS PRODUCT SHOULD BE FULLY ASSEMBLED PRIOR TO USE.**

## **SUFFOCATION HAZARD** **Infants have suffocated:**

- In gaps between extra padding and side of the bassinet, and
- On soft bedding.
- Use only the pad provided by Baby Delight, Inc..
- Never add a pillow, comforter, or another mattress for padding.
- If a sheet is used with the pad, use only the one provided by Baby Delight, Inc..
- Ensure that the side panel is locked when child is left unattended.
- Never leave infant in bassinet with side down unless it is securely positioned in sleeper mode attached to the adult bed with anchors securely in place.
- To reduce the risk of SIDS, pediatricians recommend healthy infants be placed on their backs to sleep, unless otherwise advised by your physician.

## **ENTRAPMENT HAZARD:**

- To prevent death from entrapment, bedside sleeper must be properly secured to adult bed using the attachment system.
- To avoid death from the infant's neck being caught on the top rail on the side that is next to the adult bed, the top rail must be no higher than the adult bed mattress.
- There must be no more than 1/2 inch (13mm) gap between bedside sleeper and adult bed.
- Check tightness before each use by pulling bedside sleeper in a direction away from adult bed.
- If gap exceeds 1/2 inch (13mm), DO NOT use product. Do not fill the gap with pillows, blankets or other items that are suffocation hazards.
- Always read and follow assembly instructions for each product use mode (bedside sleeper/bassinet).
- Always use ALL required parts for each use mode (bedside sleeper/bassinet).
- Check instruction manual for a list of required parts. Regularly check product before each use for loose, damaged, or missing parts. DO NOT use it if any part is loose or missing, or if there are any signs of damage. DO NOT substitute parts. Contact Baby Delight, Inc. if replacement parts or instructions are needed.

# ⚠️ WARNING - CONTINUED

## FALL HAZARD:

- To help prevent falls, do not use this product when the infant begins to push up on hands and knees, can roll over or has reached 20 lbs., whichever comes first.
- Always use all required parts for each use mode (bedside sleeper/bassinet).
- Strings can cause strangulation! NEVER place product near window blinds or patio doors with cords where a child could reach the cord and be strangled, or hang strings over the product or place items with a string around an infant's neck such as hood strings or pacifier cords or attach strings to toys.
- DO NOT place any cord or strap or similar item in or near this product that could become wrapped around a child's neck.
- In bassinet mode - ensure side panel is locked.

NEVER USE THIS PRODUCT IN BEDSIDE SLEEPER MODE WITHOUT THE ANCHOR PLATES SECURELY ATTACHED TO THE ADULT BED



ACCEPTABLE BED FRAME IN-LINE

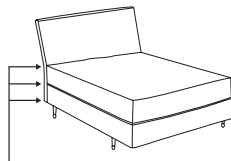

MATTRESS, BOXSPRINGS & FRAME ALIGNED

UNACCEPTABLE BED, MATTRESS, BOXSPRING & FRAME NOT IN-LINE

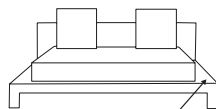

FRAME EXTENDED

## SUFFOCATION, ENTRAPMENT AND FALL HAZARDS:

- ALWAYS raise side with zipper (completely closed) to use bassinet mode.
- ALWAYS push adult mattress against bedside sleeper after securing to bed with safety strap and anchor plates.
- NEVER leave infant in bassinet mode with sides down. Ensure that the side panel is locked/zipped when child is left unattended.
- This bedside sleeper is designed for use only with adult beds that are between 17" – 25" (43cm – 63cm) from floor to top of adult mattress.
- The anchor plate and straps assembly must always be used in bedside sleeper mode. Product in bedside sleeper mode must be tightly attached to adult bed mattress to ensure safe use.
- It is recommended to make the strap shorter than the width of the mattress to ensure bedside sleeper is pressed securely against the adult bed, without any gaps.
- A bedside sleeper is designed to provide a sleeping area for an infant until he or she begins to push up on hands and knees or approximately 5 months of age. Move your child to another sleeping product when your child reaches this stage.

# Assembly/Operating Instructions

## Assembling the bassinet:

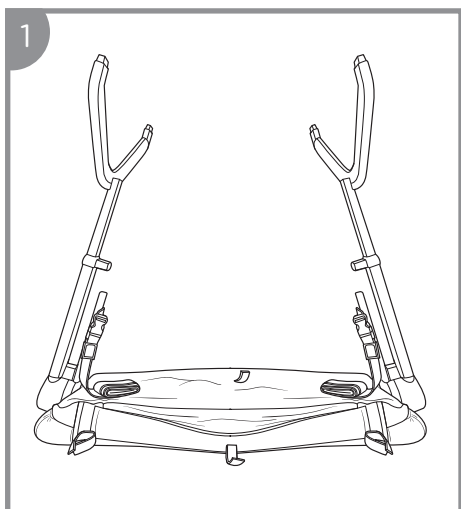

Lay the SLEEPER FRAME face down on a flat surface.

Holding the CENTRAL SUPPORTING STRUCTURE, open both of the LEGS outward.

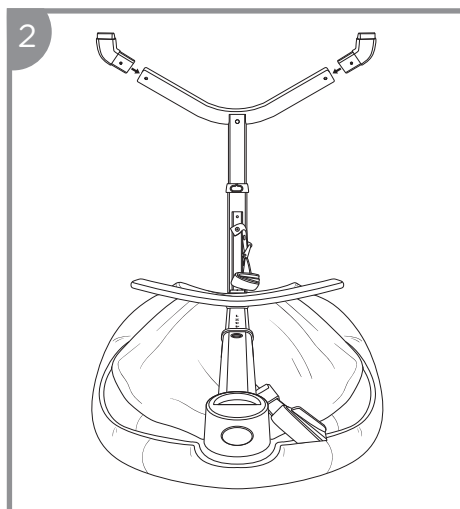

Plug in FRONT AND BACK FEET (2 sets) into SLEEPER FRAME LEGS by lining up the buttons and holes on the inside of the legs until you hear a click. The FEET should sit flat on the floor when the BASSINET is upright.

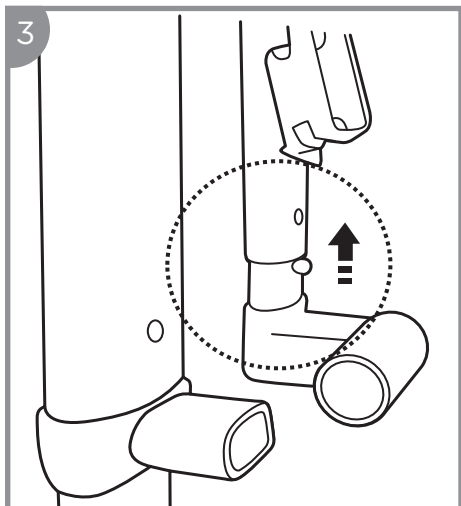

Plug in MIDDLE SUPPORT BAR KNUCKLES to FRAME on each side matching the engraved "L" and "R" on the KNUCKLES to the "L" and "R" on the FRAME.

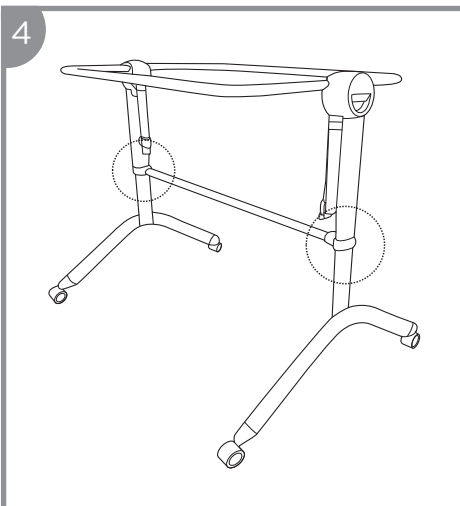

Insert MIDDLE SUPPORT BAR into FRAME on each side until you hear a click. NOTE: You may need to spread the FRAME slightly to insert the MIDDLE SUPPORT BAR.

## Assembly/Operating Instructions - Continued

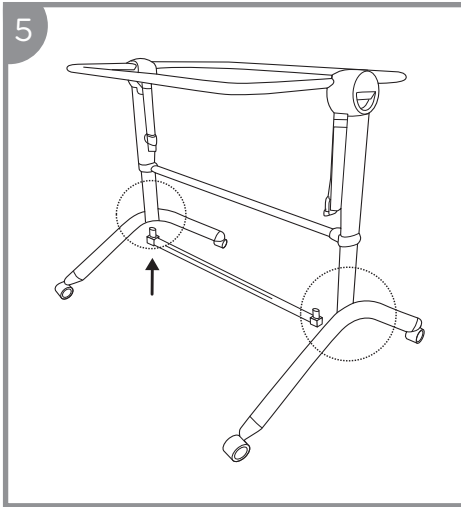

Insert **BOTTOM SUPPORT BAR** up into the **FRAME** until it is snapped in.

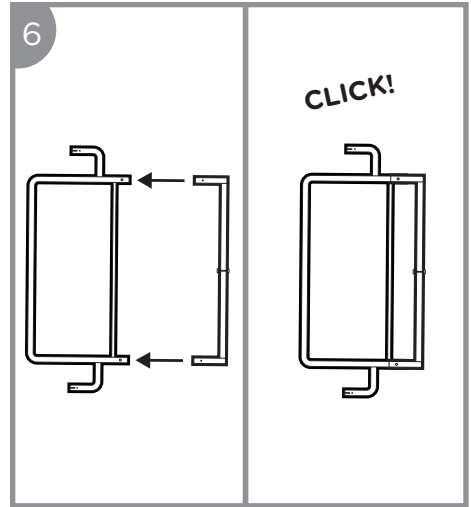

Insert the **SIDE RAIL** into the **MIDDLE SUPPORT FRAME**, by lining up the buttons and holes, until you hear a click.

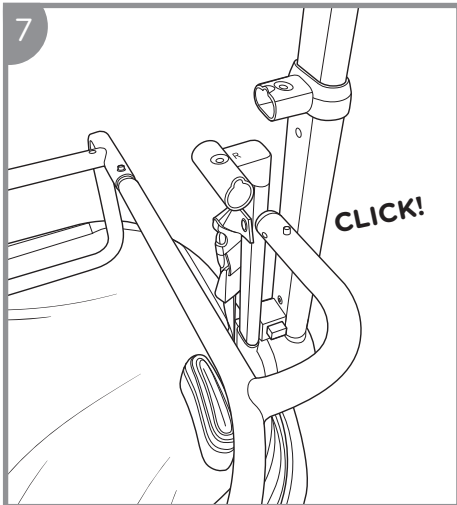

Push **MIDDLE SUPPORT BAR** into the **KNUCKLES** until you hear a click. Make sure both sides are secured.

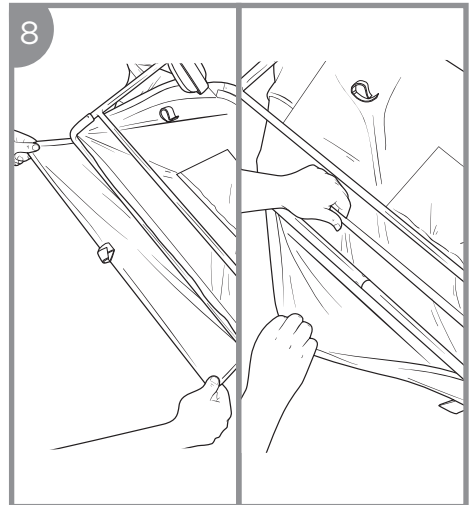

Lift **FRONT PANEL FABRIC** over the **MIDDLE SUPPORT FRAME** AND **INSERT** into fabric pocket. Secure fabric to **FRAME** with 4 loop fasteners.

## Assembly/Operating Instructions Continued

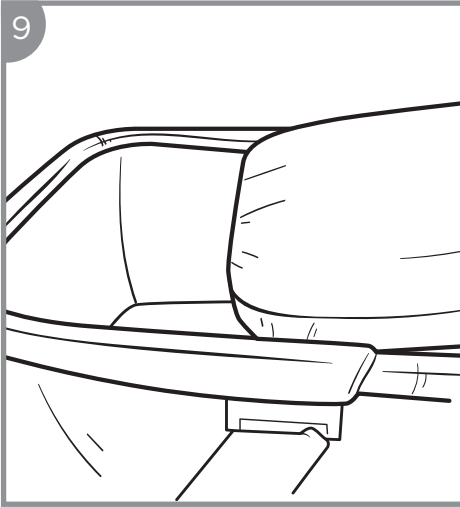

Once the FRAME is secure, place the MATTRESS with SHEET into the BASSINET with the curved edge of the MATTRESS facing the curved edge of the BASSINET.

### Height adjustment of the bassinet:

The BASSINET has **7 height positions**.

Press the HEIGHT ADJUSTER BUTTONS on the top and side of the frame on each side to lift or lower the BASSINET until a you hear a click. ALWAYS make sure the BASSINET IS ADJUSTED to the same height (by looking at the numbers) on each side.

The BEDSIDE SLEEPER is designed for use only with adult beds that are between 17" and 25" (43cm - 63cm) from floor to top of adult mattress.

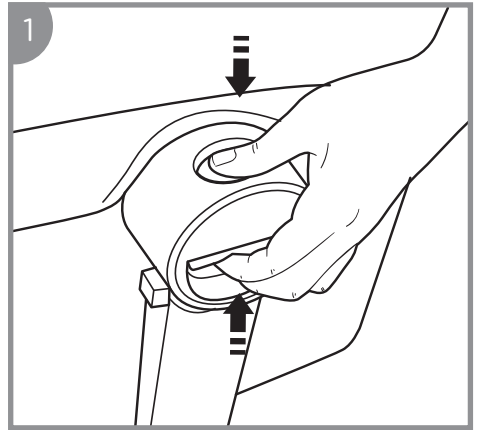

## Bedside Sleeping Mode

### **⚠ WARNING - IMPORTANT FOR THE SAFETY OF YOUR CHILD:**

THIS METHOD IS ONLY POSSIBLE WITH BED TYPES THAT COMPLY WITH ALL OF THE CONDITIONS DESCRIBED IN THIS PARAGRAPH.

IN PARTICULAR, THE SIDE SUPPORT OF THE BEDSIDE SLEEPER SHOULD ALWAYS BE PUT CLOSE TO THE PARENT'S MATTRESS AND THE MATTRESS SHOULD ALWAYS BE ALIGNED WITH THE HEIGHT OF THE SIDE SUPPORT FOR RESTRAINT OF THE BEDSIDE SLEEPER. FURTHERMORE, THE BEDSIDE SLEEPER SHOULD BE FIRMLY FIXED TO THE STRUCTURE OF THE PARENT'S BED OR TO THE MATTRESS SUPPORT.

### **⚠ WARNING!**

CHECK TO MAKE SURE THAT THE BEDSIDE SLEEPER IN THE BEDSIDE SLEEPER MODE DOES NOT INTERFERE WITH THE PARENT'S BED.

### **⚠ WARNING!**

DURING USE, MAKE SURE THAT THE PARENT'S BED SHEETS, BLANKETS ETC, DO NOT ENTER AND COVER THE INTERIOR OF THE BEDSIDE SLEEPER.

Bedside sleeper mode (attaching to the bed):

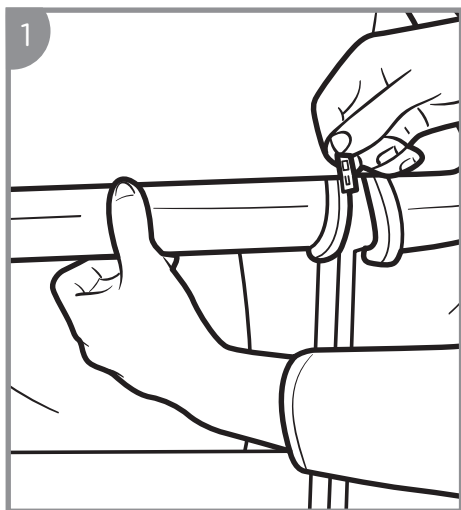

Unzip the SIDES of the BEDSIDE SLEEPER until they are completely unzipped.

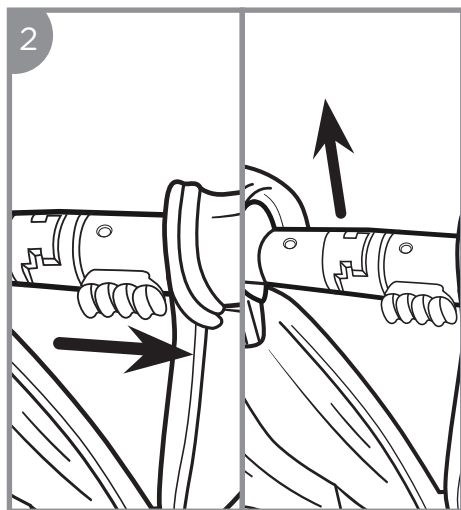

Slide the TOP BAR LOCK LEVER away from the top bar and lift TOP BAR out of GROOVE on both sides and fold down.

## Bedside Sleeping Mode - Continued

3. Move the bedside sleeper close to the parent's bed and check the height of the BEDSIDE SLEEPER compared with the mattress on the bed. The SIDE SUPPORT of the sleeper should always be placed close to the parent's mattress and the mattress should always be aligned with the height of the SIDE SUPPORT for restraint of the sleeper.

### **! WARNING:**

**IN THE BEDSIDE SLEEPER MODE THE TWO LEGS OF THE BEDSIDE SLEEPER SHOULD ALWAYS BE ADJUSTED TO THE SAME HEIGHT.**

4. In order to attach the bedside sleeper to the parent's bed in BEDSIDE SLEEPER mode, use the attached pair of ANCHORS provided.

5. Slide the ANCHORS between the top mattress and the base across the opposite side of the bed using a back and forth 'sawing' motion and at the same time pulling downward until the STRAPS and ANCHOR PLATES are in the desired position.

### **! WARNING:** ENSURE THE ANCHORS ARE STRAIGHT.

6. Tighten the LOOP by pulling the BELTS firmly. Adjust the ANCHOR STRAPS separately until the BEDSIDE SLEEPER is firmly in contact with the parent's mattress.

**NEVER USE THIS  
PRODUCT IN  
BEDSIDE SLEEPER  
MODE WITHOUT  
THE ANCHOR  
PLATES SECURELY  
ATTACHED TO THE  
ADULT BED**

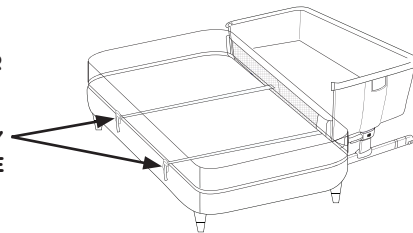



## Care & Cleaning - Continued

### Removing the cover:

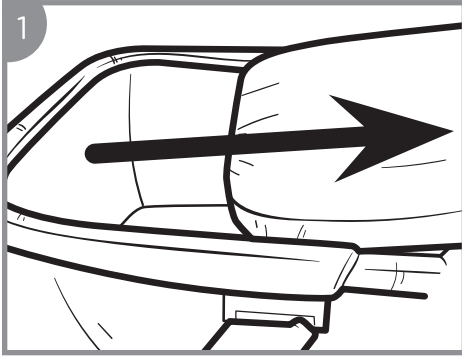

Remove the MATTRESS and release the hook and loop tabs from the MIDDLE SUPPORT FRAME on the underside of the bassinet.

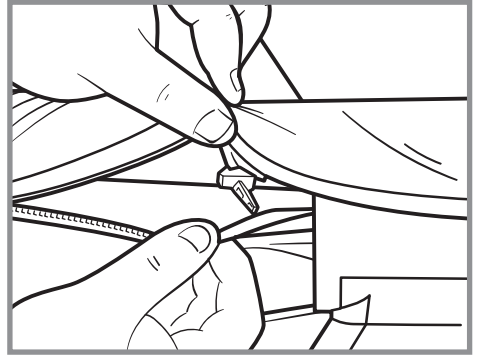
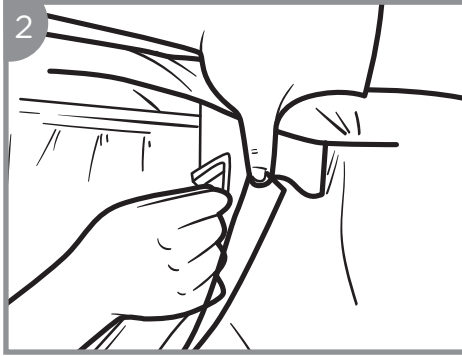

Release the hook & loop tabs from the TOP RAIL COVER of the bedside sleeper as per image. Locate the ZIPPER underneath the FABRIC LIP of the structure and unzip.

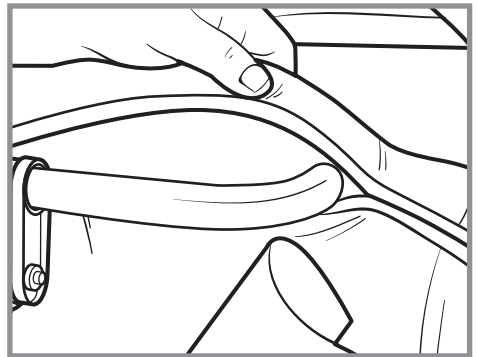
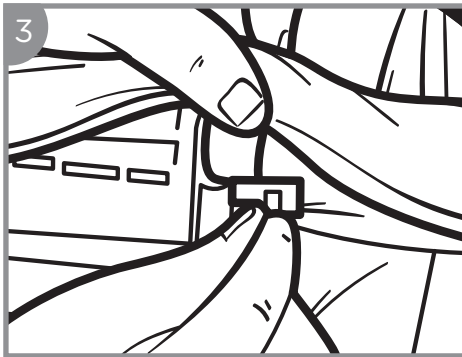

Gently remove the LINING from the UPPER TUBULAR STRUCTURE, making sure not to damage the internal part of the LINING.

# How to Care for Your Beside Me™ Wink

## Maintenance:

The BASSINET and MATTRESS FABRIC COVER are completely removable and washable.

The removal of the fabric should be carried out by an adult only. On a regular basis check the condition of the product and presence of any possible damage. In the case of damage do not use and keep it out of the reach of children.

## Cleaning:

Do not use solvents, abrasives or aggressive products. After each wash check the resistance of the fabric and the stitching. For washing of the fabric, carefully comply with instructions indicated on the label.

## Limited Warranty

At Baby Delight, Inc. we make innovative and high quality products for babies, children and their parents. We warrant this product to be free from defects in material and workmanship existing at the time of manufacture for a period of 90-days from the date of initial purchase (sales receipt is required for proof of purchase). If such a defect is discovered during the limited warranty period, we will, at our sole option, repair or replace your product at no cost to you.

This limited warranty does not cover claims resulting from misuse, failure to follow the instructions on installation, maintenance and use, abuse, alteration, involvement in an accident, and normal wear and tear.

DO NOT use bedside sleeper if any parts are missing, damaged, or broken. Contact for replacement parts and instructional literature if needed. DO NOT substitute parts.

For warranty service or replacement part information:

USA: Please call Customer Service at 1-401-333-6800, email at [consumercare@babydelight.com](mailto:consumercare@babydelight.com), or mail 30 Martin Street, Suite 3C, Cumberland, RI 02864.



[www.babydelight.com](http://www.babydelight.com)

©2020 Baby Delight, Inc. 1-401-333-6800 [consumercare@babydelight.com](mailto:consumercare@babydelight.com)

**BD06120, BD05080**