

Contact Us: *FACTORY UTV LLC*

9237 Beatty Drive Sacramento, CA 95826

Phone : (916) 383-2730

E-mail : info@factoryutv.net

Go online: www.Factoryutv.net



FACTORY UTV

U.H.M.W. Skid Plate / Under Armor Package

Ultra. High. Molecular. Weight. polyethylene all terrain skid plate / under armor kit for UTV's

Installation Guide (Ultimate Package)

Polaris

Ranger XP 900/1000 (2013-18+)



Polaris Ranger XP 900/1000 (2013-2018+) instructions

Remove stock skid plate and re-use stock hardware as needed in all (A) locations.

#1

Main Skid Plate :

Install using : (10x) Stock Bolts & Washers *in Main Skid: (A) locations,*

**(See Drilling Instructions Below)* Mark, drill and install: (2x) ¼"-20 x ¾" Self Tapping Bolts in Main Skid : (B) locations. (2014-17 models use stock Hw for top, center B locations)*

#2

Rear Skid Plate :

**(See Drilling Instructions Below)* Align edge with Main Skid. Mark, drill and install: (6x) ¼"-20 x ¾" Self Tapping Bolts in Rear Skid : (B) locations. In the 2x rear most (B) locations. Drill in to crease of metal, between hump and flat areas. (See chassis diagram pg.3)*

(Mount forward bolts first, to aid positioning of rear skid and chassis frame.)

#3

Diff. Skid Plate :

*Bend front tab inwards, see: chassis diagram pg.3. *(See Drilling Instructions Below)* Align edge with Main Skid. Mark, drill and install: (4x) ¼"-20 x ¾" Self Tapping Bolts in Diff. Skid : (B) locations.*

#4

Side Mounts (C):

2018 models - Install: (6x) M6- 1.0 x 25mm Flange Bolts in Main Skid : (C) locations.

2014-17 Models - *(See Drilling Instructions Below) *Align, mark, drill, and

Install: (8x) ¼"-20 x ¾" Self Tapping Bolts in Main Skid : (B) locations. Also, Use B bolts for C locations.

RS

If Rock Sliders :

2018 models - Install: (6x) M6- 1.0 x 30mm Flange Bolts " RS" in Main Skid : (C) locations.

2014-17 models - *(See Drilling Instructions Below)* Mark, drill and Install:

(8x) ¼"-20 x 1 ¼" Self Tapping Bolts " RS" In main skid : (B) locations.

In lieu of (C) bolts, Place Rockslider in-between skid and chassis Frame.

G

Rear A-Arm Guards : (G)

Install : (4x) ¼"-20 x 2 ¼" Counter Sunk Bolts W/ (4x) ¼" Zinc Washers, and (4x) ¼" x 20 Ny-Lock Nuts in : (G) locations. (on Each Rear A-Arm Guard).

D+E

A-Arm Guards : (D) (E)

Install : (3x) 1 x 1" "D" clamps over A-Arm tubing W/ (3x) ¼"-20 x 1 ¼" Counter Sunk Bolts, (3x) ¼" Gold Washers, and (3x) ¼"-20 Ny-Lock Nuts in: (D) locations.

Install : (1x) ¼"-20 x 1 ½" Counter Sunk Bolts, W/ (1x) ¼" Gold Washers, and (1x) ¼"-20 Ny-Lock Nuts through stock mounting holes in: (E) locations. (on Each A-Arm Guard)

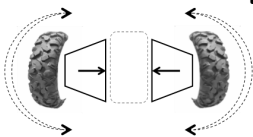

** Ensure Clearance For Turn Radius & Vertical Travel*

Before Fastening ALL Bolts Securely

* Drilling Instructions : *

Use a : #No7 (13/64th) drill bit,

(one size above the commonly available 3/16th bit) Recommended ¼"- 20 Tap *(Optional)

To drill and thread self tapping bolts in to chassis frame.

Finger Thread All Bolts Prior To Fastening Securely With Power Tools.

We strongly recommend the use of a "Thread Locking Compound" when installing any mounting hardware.

(When installation is complete , ensure all bolts are fastened securely.)



See: Chassis Diagram pg.3



*(Align Edge)

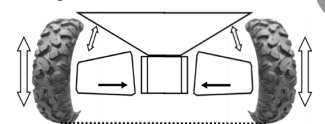

Polaris Ranger XP 900/1000 (2013-2018+)

Read :
 Instructions on pg.#2
 Remove stock skid plate,
 reuse hardware as needed.
 Skid plate will form to fit.
 See drilling instructions
 prior to drilling.

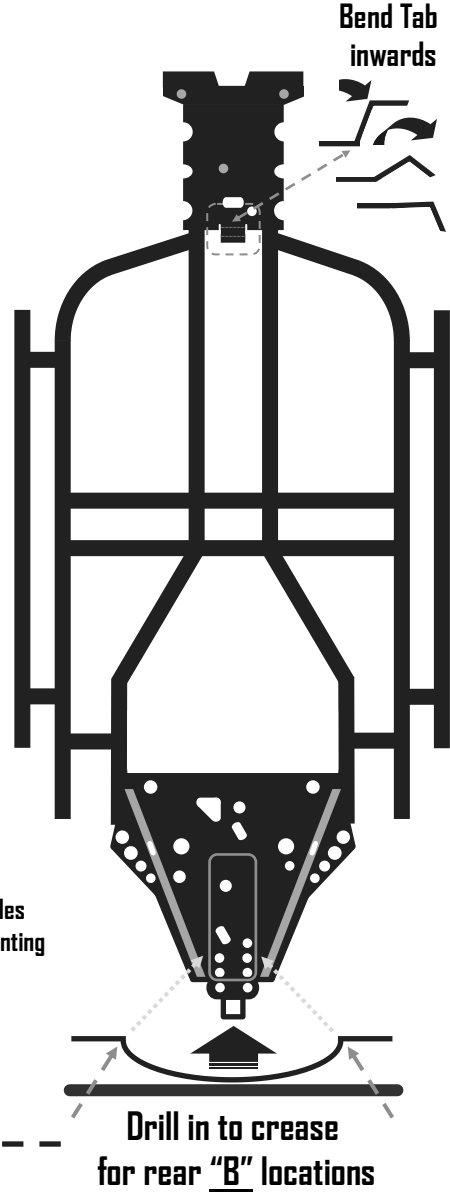
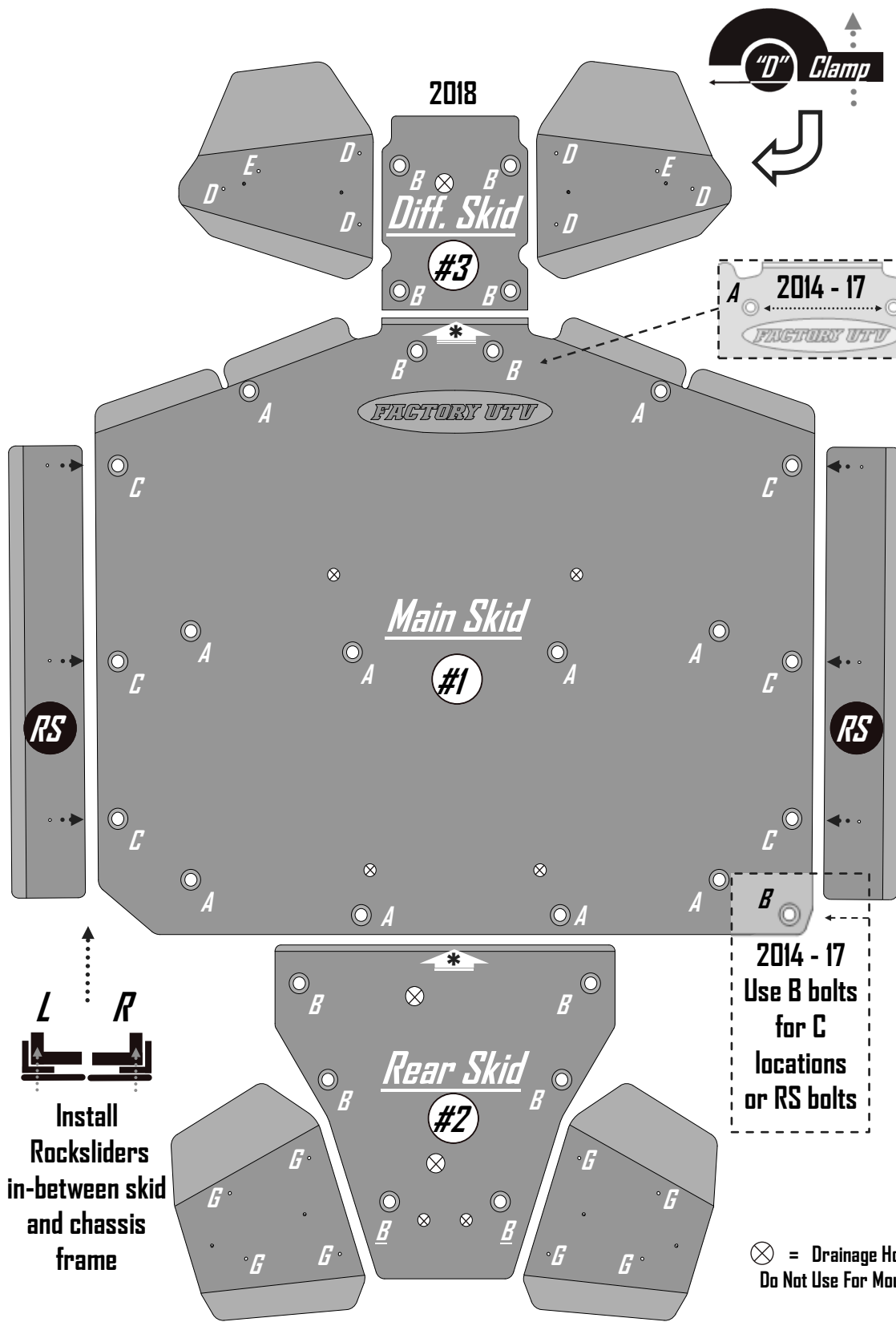

*Fasten 2013 Rear a-arms in similar configuration.

Polaris Ranger XP 900/1000 (2013-2018+) Hardware kit

2018 Skid Hardware

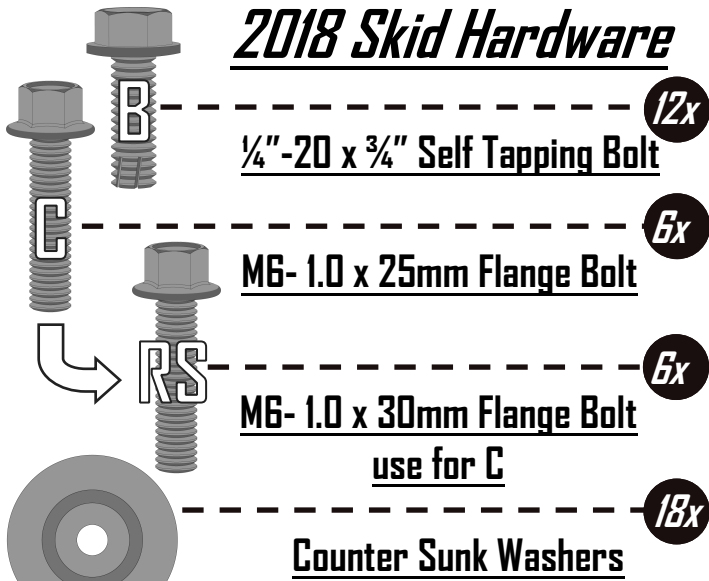

2013-17 Skid Hardware

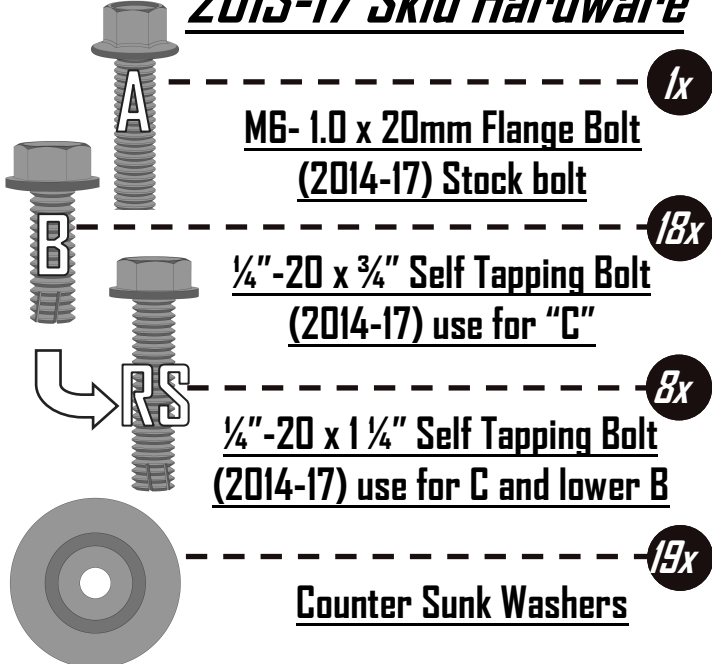

** (All bolt lengths here are sized to scale.)*

2014-18 Front A-Arm Hardware

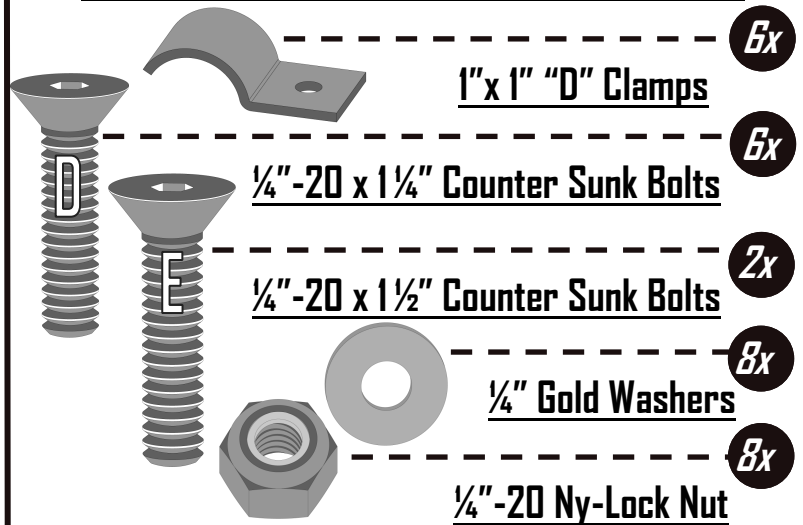

2018 Rear A-Arm Hardware

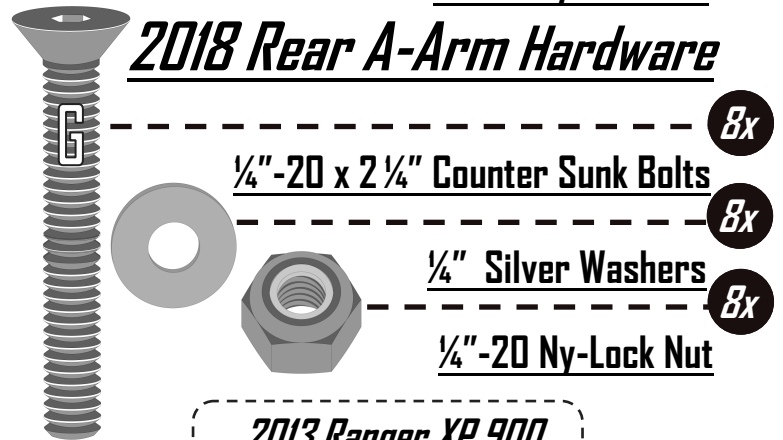

2013 Ranger XP 900 A-Arm hardware

2013 Front A-Arm

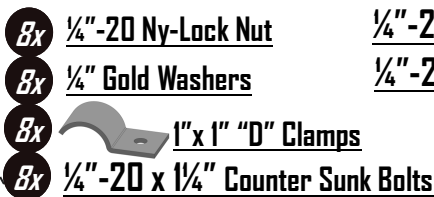

2013-17 Rear A-Arm

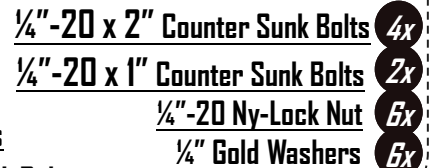

*** Drilling Instructions : ***

Use a : #N^o7 (13/64th) drill bit,

(One size above the commonly available 3/16th bit) Recommended use with a 1/4"-20 Tap *(Optional)

To drill and thread self tapping bolts in to chassis frame.

Finger Thread All Bolts Prior To Fastening Securely With Power Tools.

We strongly recommend the use of a "Thread Locking Compound" when installing any mounting hardware.

(When installation is complete, ensure all bolts are fastened securely.)