

Contact Us: FACTORY UTV LLC

9237 Beatty Drive Sacramento, CA 95826

Phone : (916) 383-2730

E-mail : info@factoryutv.net

Go online: www.Factoryutv.net



U.H.M.W. Skid Plate / Under Armor Package

Ultra. High. Molecular. Weight. polyethylene all terrain skid plate / under armor kit for UTV's

Installation Guide (Ultimate Package)

Polaris

RZR XP4 Turbo S (2018) (2019-2020+)



Polaris RZR XP4 Turbo S (2018) (2019-2020+) Instructions

Remove stock skid plate, Install brackets, and re-use stock hardware as needed in all (A) locations.

- **Turbo S Bracket** : Install with J-clip tips pointing up, towards vehicle. Align bracket edge with front differential plate, mark, drill and install: (2x) $\frac{1}{4}$ "-20 x $\frac{3}{4}$ " Self Tapping Bolts in center : (C) locations. (See drilling instructions below & diagram on pg.3)
- **Angle Brackets** : Thread stock, self tapping "A" bolts in to un-threaded holes in *Angle Bracket (A) locations*. (see pg.3) - $\frac{1}{4}$ "-20 Tap Recommended
- **Cross Member** : Bolt (2x) "D" clamps w/ (2x) M6-1.0 x 20mm Flange Bolts to crossmember, over tubing in (E) locations. Use (1x) stock bolt in (A) location. Remaining (E) locations for used for skid plate install.

#1

Mid and Main Skid Plate :

Install mid skid, then main skid using: (14x) stock bolts, in center of mid and main skid: (A) locations,
Install: (2x) M6-1.0 x 25mm Flange Bolts, with (2x) "D" Clamps in main skid: (D) locations.

Install: (2x) M6-1.0 x 25mm Flange Bolts, in mounting bracket main skid: (D) locations. Disregard side (B) bolt locations until later steps.



#2

Rear Skid Plate :

(See Drilling Instructions Below) Align edge, mark, drill, and

Install: (6x) $\frac{1}{4}$ "-20 x 1" Self Tapping Bolts in Rear skid: (B) locations.

Install: (2x) $\frac{1}{4}$ "-20 x 1 $\frac{1}{2}$ " Self Tapping Bolts with (2x) - (S) Nylon Spacers in rear skid: (G) locations. Use of: $\frac{1}{4}$ "-20 Tap Recommended



#3

Front Diff. Skid Plate :

(See Drilling Instructions Below)

Align edge with main skid, mark, drill, and install: (2x) $\frac{1}{4}$ "-20 x $\frac{1}{2}$ " Self Tapping Bolts in front diff. skid: (F) locations.

Install: (2x) $\frac{1}{4}$ "-20 x $\frac{3}{4}$ " Self Tapping Bolts in front diff. skid: (C) locations.

Install: (2x) $\frac{1}{4}$ "-20 x 1" Self Tapping Bolts in front diff. skid: (B) locations.

Double wall plating on front diff (B) locations: (see pg.3)

Drill $\frac{5}{16}$ th clearance holes in first layer, then drill and/or tap smaller hole in backing layer for self tapping bolts.



#4

Side Mounts (B):

(See Drilling Instructions Below)

Align, mark, drill, and Install: (8x) $\frac{1}{4}$ "-20 x 1" Self Tapping Bolts in side main and mid skid : (B) locations.

If Rock Sliders :

Use: (8x) $\frac{1}{4}$ "-20 x 1 $\frac{1}{4}$ " Self Tapping Bolts, "RS" bolts in main skid : (B*) locations.

In lieu of (B) side bolts ($\frac{1}{4}$ "-20 x 1" Self Tapping Bolts) install between skid and chassis frame.



T:1

Trailing Arm Guards : (T:1)

Install: (5x) $\frac{1}{4}$ " x 20 x 3" Hex Bolts W/ (10x) $\frac{1}{4}$ " Zinc Washers, and (5x) $\frac{1}{4}$ " x 20 Ny-Lock Nuts

In : (T) locations. (On each trailing arm guard).



A:1

A-Arm Guards (A:1)

Install: (5x) 1" x 1 $\frac{3}{8}$ " "D" Clamps over A-Arm tubing,

W/ (5x) $\frac{1}{4}$ "-20 x 1 $\frac{1}{4}$ " Counter Sunk Bolts, (5x) $\frac{1}{4}$ " Gold Washers, and (5x) $\frac{1}{4}$ "-20 Ny-Lock Nuts For Each A-Arm in: (A:1) locations.

Install bolts loosely during install for adjustment, Fasten bolt head flush and securely when complete, do not over tighten.

* **Ensure** Clearance For Turn Radius & Vertical Travel

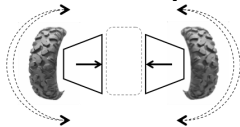

before Fastening securely

* **Drilling Instructions :** *

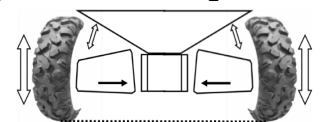

Use a : #No7 (13/64th) drill bit,

(one size above the commonly available 3/16th bit) We recommend ($\frac{1}{4}$ "-20) Tap for drilled locations.

To drill and thread self tapping bolts in to chassis frame.

Finger Thread All Bolts Prior To Fastening Securely With Power Tools.

We strongly recommend the use of a "Thread Locking Compound" when installing any mounting hardware.

(When installation is complete , ensure all bolts are fastened securely.)



Polaris RZR XP4 Turbo S (2018) (2019-2020+)

Install brackets.
 Re-use stock hardware.
 Tighten skid bolts loosely for install adjustments, fasten securely when complete.

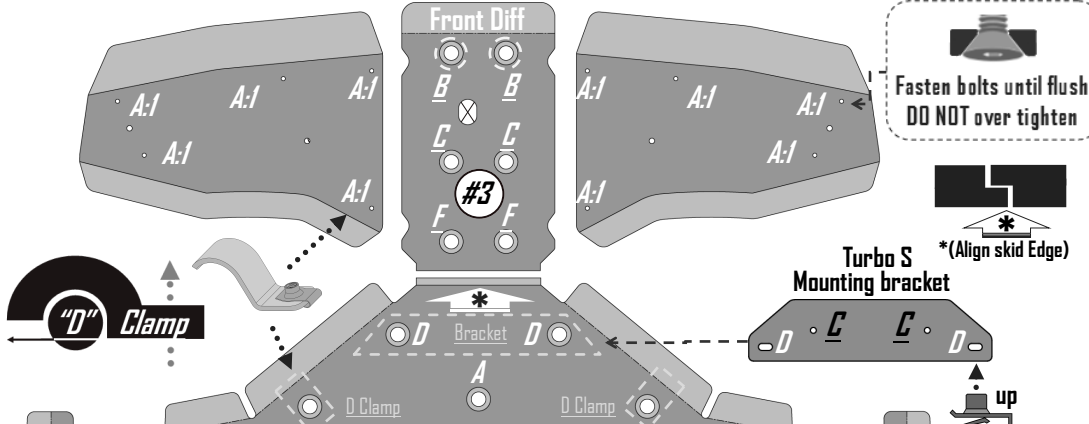

Front Diff Double Wall Plating:
 In Front 2x B Locations only
 Carefully Drill $\frac{5}{16}$ " clearance holes in first layer.
 Drill and/or tap $\frac{13}{64}$ " mounting hole, in backing plate before fastening bolts securely.

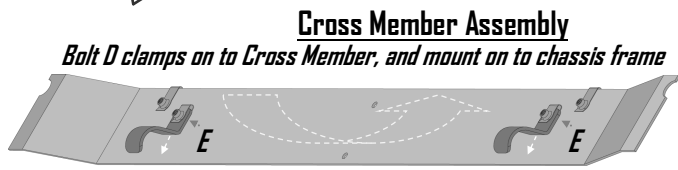
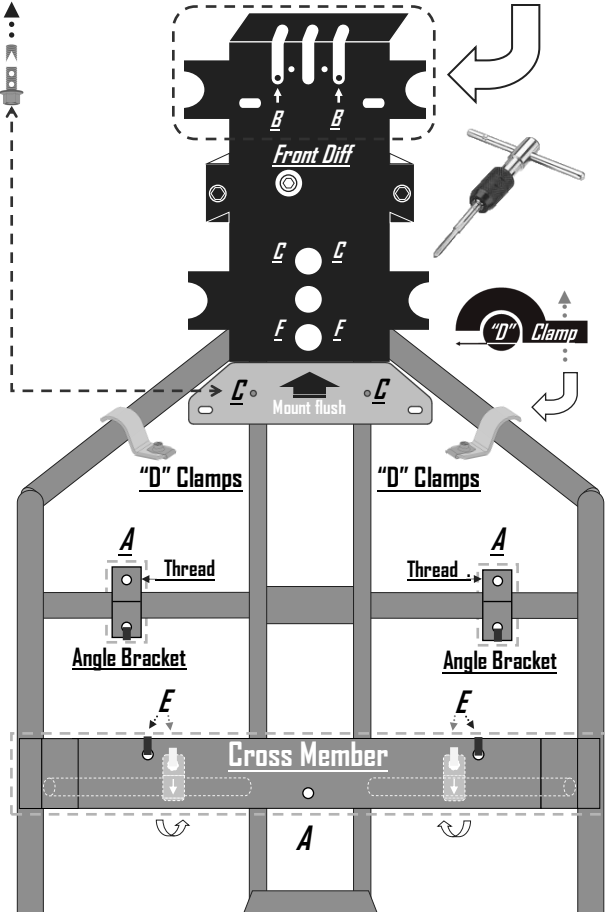
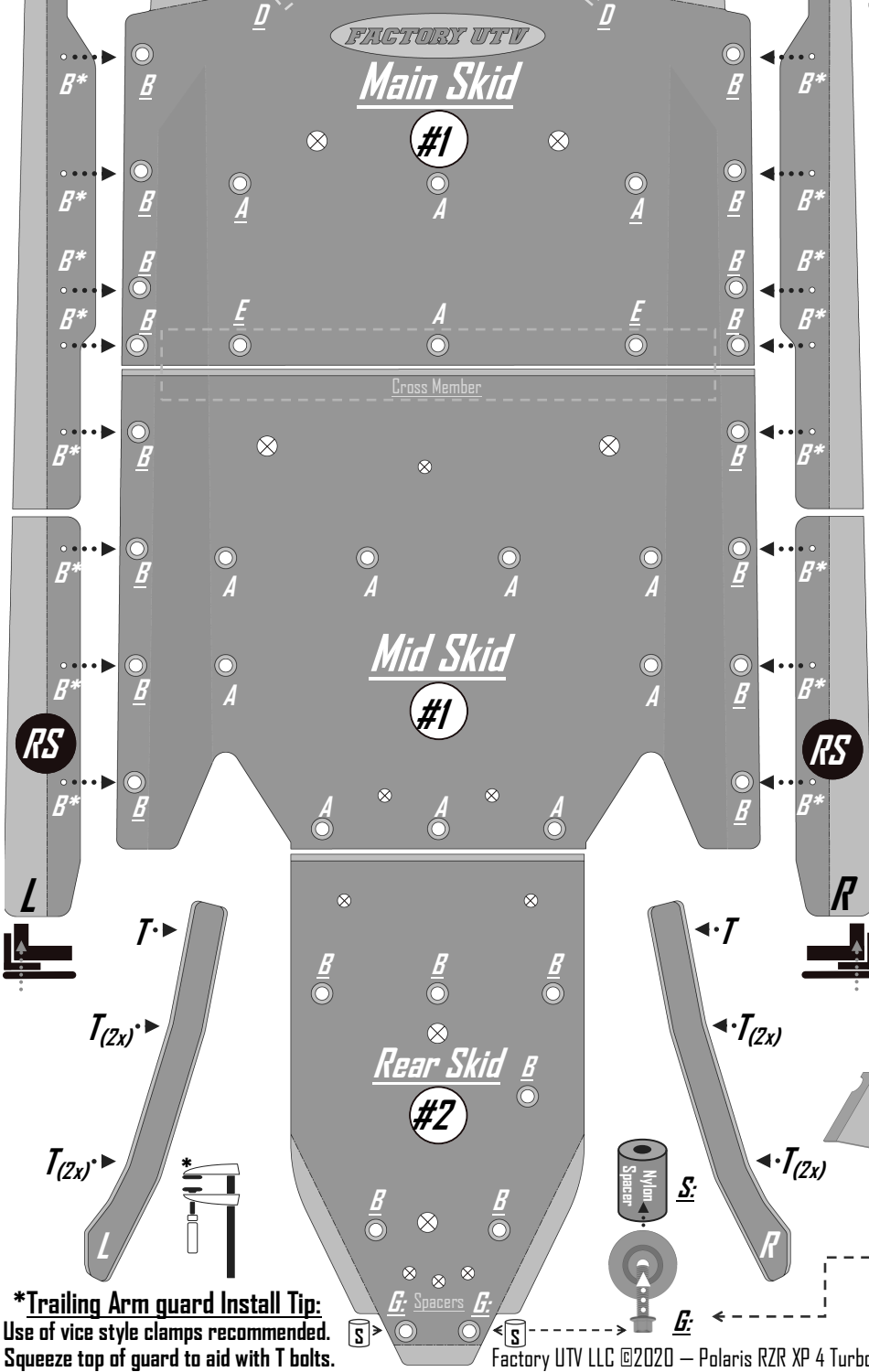

$\frac{1}{4}$ "-20 Tap is Recommended for G locations





⊗ = Drainage Holes
 Do Not Use For Mounting

***Trailing Arm guard Install Tip:**
 Use of vice style clamps recommended.
 Squeeze top of guard to aid with T bolts.





Polaris RZR XP4 Turbo S

(2018) (2019-2020+)



#3 Front Diff Skid small bag:

-  2x
1/4"-20 x 3/4" Self Taping Bolt (#B-D:2)
-  2x
1/4"-20 x 1" Self Taping Bolt (#B-D:3)
-  2x
1/4"-20 x 1/2" Self Taping Bolt (#B-D:5)
-  6x
Counter Sunk Washers (#W-1)





#2 Rear Skid small bag:

-  6x
1/4"-20 x 1" Self Taping Bolt (#B-D:3)
-  2x
1/4"-20 x 1/2" Self Taping Bolt (#B-D:6)
-  2x
3/4 Nylon Spacers (#S-R:4)
-  8x
Counter Sunk Washers (#W-1)



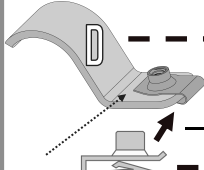

#4 Side bolts small bag:

-  16x
1/4"-20 x 1" Self Taping Bolt (#B-D:3)
-  16x
Counter Sunk Washers (#W-1)
-  *If: Rock Slider 's replace >* 16x
1/4"-20 x 1 1/4" Self Taping Bolt (#B-D:4)



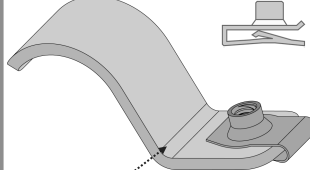

#5 Main Skid Large bag:

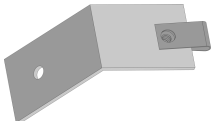
-  2x
1 1/2" x 1 1/4" short "D" Clamps (#C-D:4)
-  2x
J-Clip (installed on D clamp) (#N-13)
-  4x
M6- 1.0 x 25mm Flange Bolt (#B-A:6)
-  4x
Counter Sunk Washers (#W-1)

#6 Mounting brackets

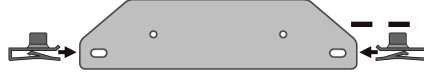
-  8x
on: Brackets, Clamps, and Cross Member.
J-Clips (#N-13)
-  2x
1 1/2" x 1 1/4" short "D" Clamps (w/ j-clips) (#C-D:4)
-  2x
M6- 1.0 x 20mm Flange Bolt (#B-A:5)
-  2x
1/4"-20 x 3/4" Self Taping Bolt (#B-D:2)
-  2x
Angle Brackets (w/ j-clips) (#C-M:3)

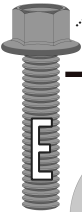
Cross Member and Turbo S bracket

-  1x
Turbo S Bracket (w/ j-clips) (#C-M:5)
(Wrapped to front diff skid plate with hardware for shipping)
-  1x
Cross Member (w/ j-clips) (#C-M:1)
(Hardware fastened to skid plate for shipping, is required for installation)
-  2x
M6- 1.0 x 20mm Flange Bolt (#B-A:5)
-  2x
Counter Sunk Washers (#W-1)

Polaris RZR XP4 Turbo S (2018) (2019-2020+)

A-Arm & Trailing Arm Guard Hardware kit

Polaris RZR XP Turbo S (2019 - 2020+) Hardware

Trailing arm small bag:

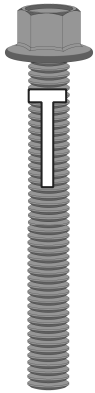

----- 10x
1/4"-20 x 3" Hex Flange Bolt (#B-H:8)



----- 20x
Zinc Washers (#W-4)

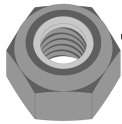

----- 10x
1/4"-20 Ny-Lock Nut (#N-2)

A-Arms large bag:



----- 10x
1"x 1 3/8" "D" Clamps (#C-D:8)

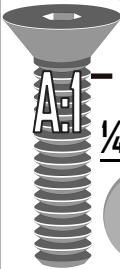

----- 10x
1/4"-20 x 1 1/4" Counter Sunk Bolts (#B-C:2)



----- 10x
1/4"sm Gold Washers (#W-3.0)

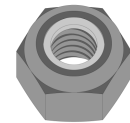

----- 10x
1/4"-20 Ny-Lock Nut (#N-2)

Polaris RZR XP Turbo S (2018) Hardware

Trailing arm small bag:

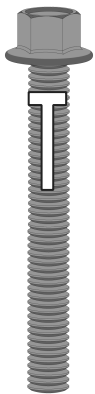

----- 10x
1/4"-20 x 3" Hex Flange Bolt (#B-H:8)



----- 20x
Zinc Washers (#W-4)

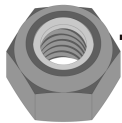

----- 10x
1/4"-20 Ny-Lock Nut (#N-2)

A-Arms large bag:

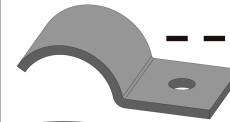

----- 10x
1"x 1 1/4" "D" Clamps (#C-D:3)

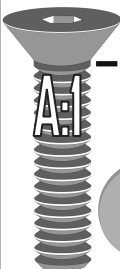

----- 10x
1/4"-20 x 1 1/4" Counter Sunk Bolts (#B-C:2)



----- 10x
1/4"sm Gold Washers (#W-3.0)

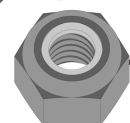

----- 10x
1/4"-20 Ny-Lock Nut (#N-2)

Go online to www.FactoryUTV.net and check out our other Turbo 4 S products:

Steel Front Bumper
with UHMW Bash Plate



Aluminum
X-Brace Plate
(Rear diff skid re-enforcement)

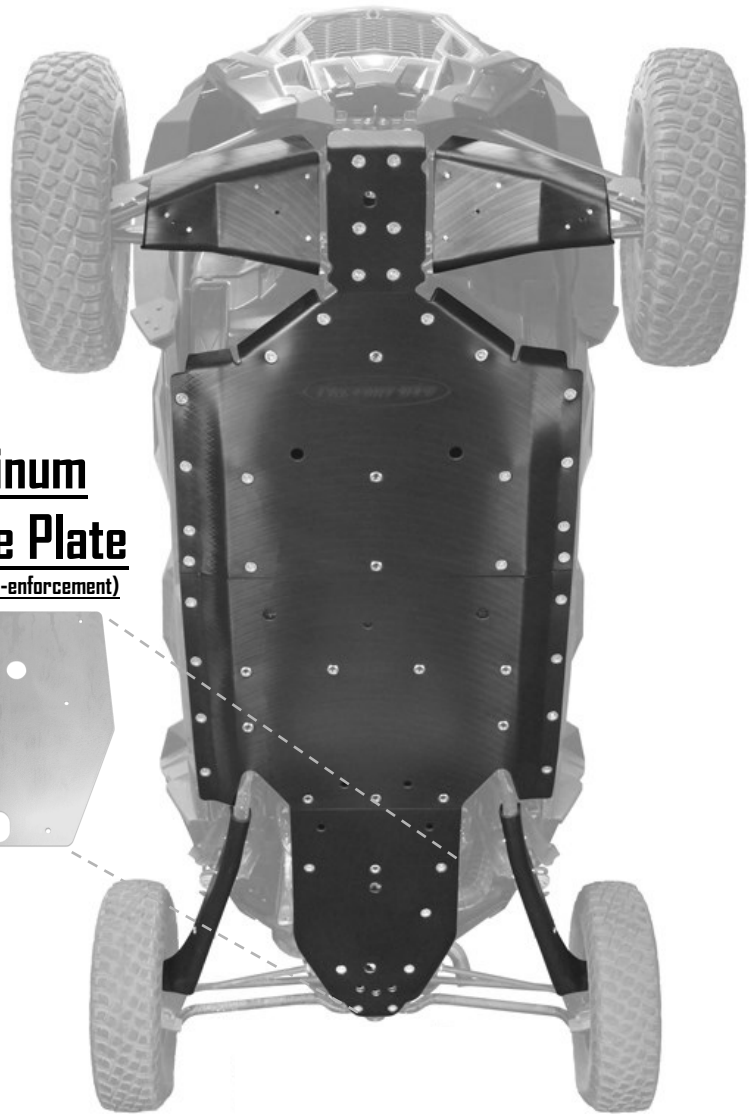
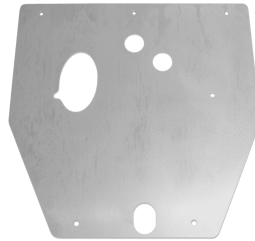

Dual Clamp
Spare Tire Mounts

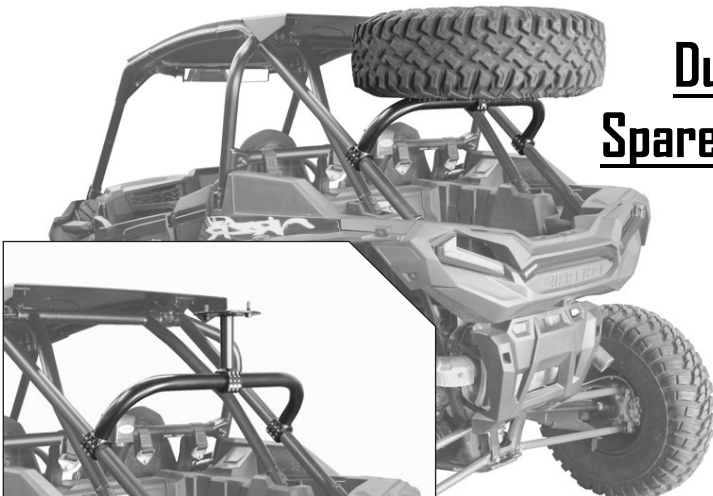

Standard Height

Above The Roof

If upgrading to an aftermarket wheel, contact us with the post measurement (see web page for details) and we can sell you just the post, to accompany your upgrade.

