

Contact Us: *FACTORY UTV LLC*

9237 Beatty Drive Sacramento, CA 95826

Phone : (916) 383-2730

E-mail : info@factoryutv.net

Go online: www.Factoryutv.net



U.H.M.W. Skid Plate / Under Armor Package

Ultra. High. Molecular. Weight. polyethylene all terrain skid plate / under armor kit for UTV's

Polaris RZR 170

(2009 - 2020+)

Installation Guide



Polaris RZR 170 (2009 - 2020+) Instructions

#0

Remove: stock skid plate.

Remove: (8x) stock nuts and bolts in floorboard and inner foot well *Main Skid: (A) locations.*

#1

Front Main Skid Plate :

You may need assistance, or the use of a car jack, to help hold skid in place.

Install: (8x) M6-1.0 x 45mm Flange Bolts and (8x) 1/4" Silver Zinc Washers, Down Through Floorboard with (8x) Counter sunk washers, and (8x) M6- 1.0 flange Nuts *in Main Skid: (A) locations.*

#2

Rear Main Skid Plate :

Install: (4x) 1" x 1 1/4"-"D" Clamps each with (1x) 1/4"-20 x 1" Counter Sunk Bolt, (1x) 1/4" Gold Washer, and (1x) 1/4"-20 Ny-Lock Nut

Install "D" clamps over vehicle tube framing *In Main Skid: (B) locations.*

Tighten counter sunk bolts until bolt head is Flush with UHMW. DO NOT Over Tighten Bolts

#3

Front Diff. Skid Plate :

Holding the front diff skid in place, loosely Install: (2x) 1" x 1 1/4"-"D" Clamps ".2" with (1x) 1/4"-20 x 1" Counter Sunk Bolts "C", (1x) 1/4" Gold Washer, and (1x) 1/4"-20 Ny-Lock Nut *in front Diff. Skid: (C.2) locations.*

Install: (1x) 1" x 1"-"D" Clamp ".1" with (1x) 1/4"-20 x 1 1/4" Counter Sunk Bolt "C", (1x) 1/4" Gold Washers, and (1x) 1/4"-20 Ny-Lock Nut

in front Diff. Skid: (C.1) location, Fasten all bolts securely. Do not over tighten.

#a

(2009-2013) Rear Swing Arm Guard :

Align swing arm guard, hold or clamp in place

Install: (3x) 1" x 1 1/4"-"D" Clamps over swingarm frame tubing with (3x) 1/4"-20 x 1" Counter Sunk Bolts, (3x) 1/4" Gold Washers, and (3x) 1/4"-20 Ny-Lock Nuts *in Rear Swing Arm: (B) locations.*

Align, mark and *Drill remaining (2x) rear holes *in (D) locations.*

Install : (2x) 1/4"-20 x 1" Counter Sunk Bolts, (2x) 1/4" Gold Washers, and (2x) 1/4"-20 Ny-Lock Nuts *in (D) locations.*

#b

(2014-2020+) Rear Swing Arm Guard :

*(if ordered a full replacement swingarm kit, hardware is pre-assembled)

Install: (6x) 1" x 1 1/4"-"D" Clamps over swingarm frame tubing with (6x) 1/4"-20 x 1 1/4" Counter Sunk Bolts, (6x) 1/4" Gold Washers, and (6x) 1/4"-20 Ny-Lock Nuts *in Rear Swing Arm: (C) locations.*

* Drilling Instructions : *

Use a : #Nº7 (13/64th) drill bit,

(one size above the commonly available 3/16th bit) Recommended 1/4"- 20 Tap *(Optional)

To drill and thread self tapping bolts in to chassis frame.

Finger Thread All Bolts Prior To Fastening Securely With Power Tools.

We strongly recommend the use of a "Thread Locking Compound" when installing any mounting hardware.

(When installation is complete , ensure all bolts are fastened securely.)

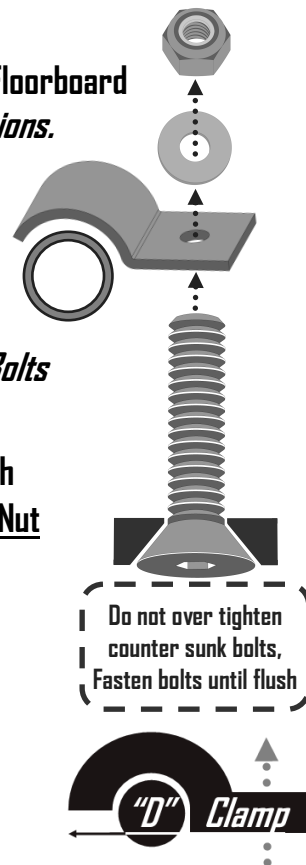

Polaris RZR 170 (2012-2018+)

Read :
 Instructions on pg.#2
 Remove stock skid plate.
 You May need assistance
 holding skid in place,
 or the use of a car jack
 during install.

⊗ = Drainage Holes
 Do Not Use For Mounting

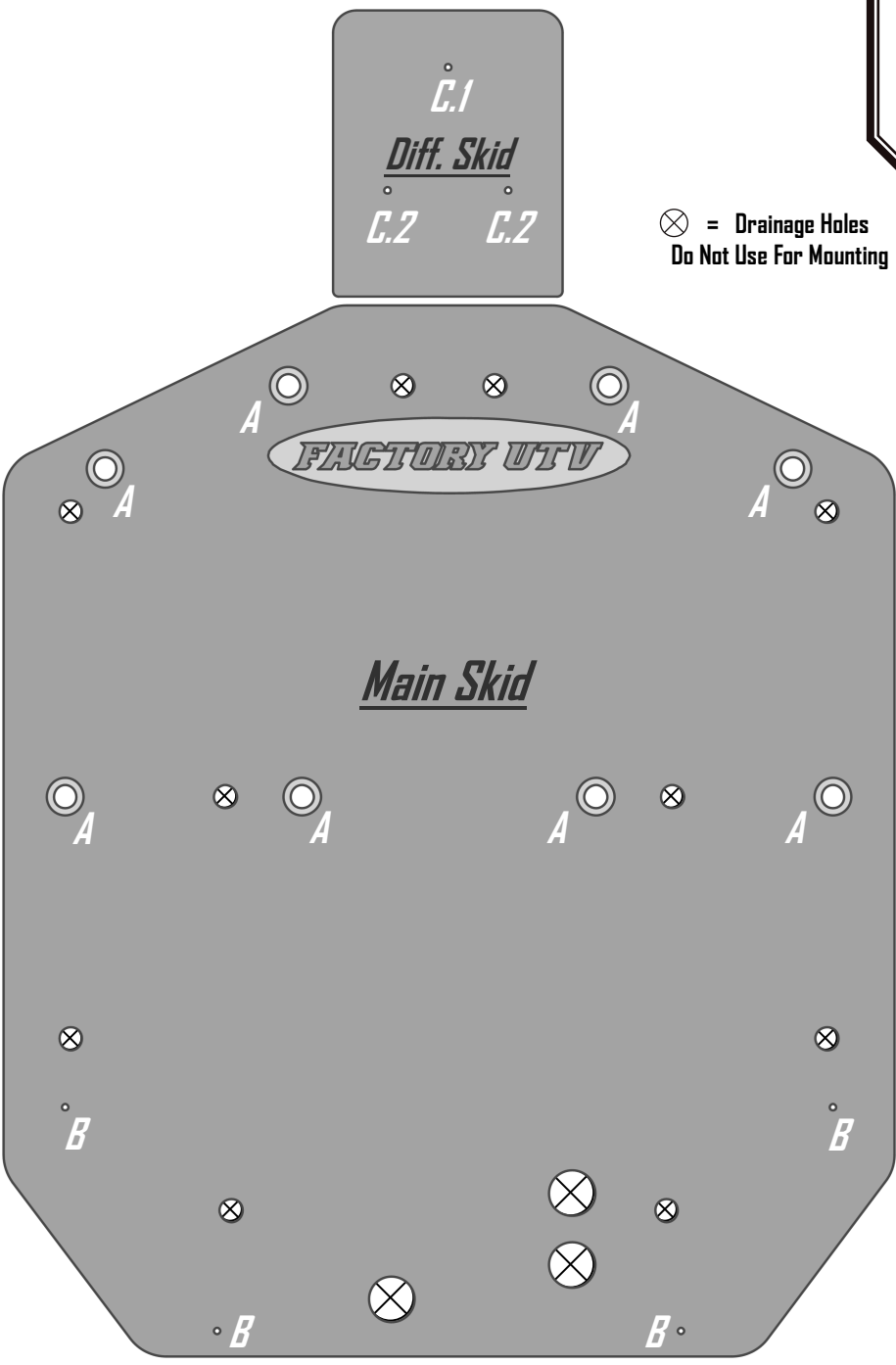

A

Install "A" bolts facing down through floor board, fasten with counter sunk washer and ny-lock nut

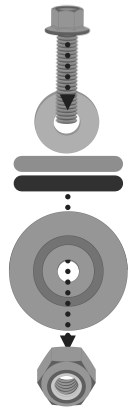

B

Install "B" bolts up from the bottom with D-clamps over tubing. Fasten bolts until flush with UHMW, DO NOT over tighten.

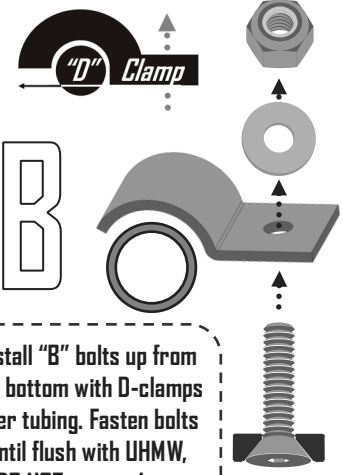

Swing Arm Guard

2009 - 2013

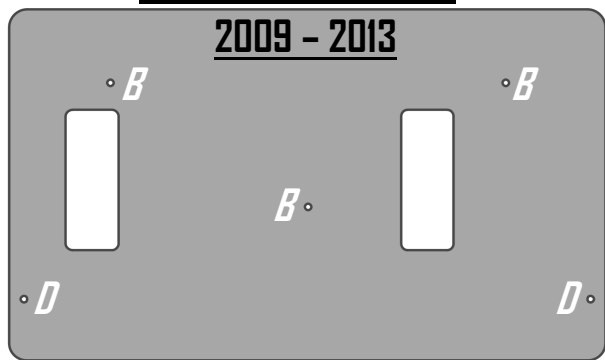



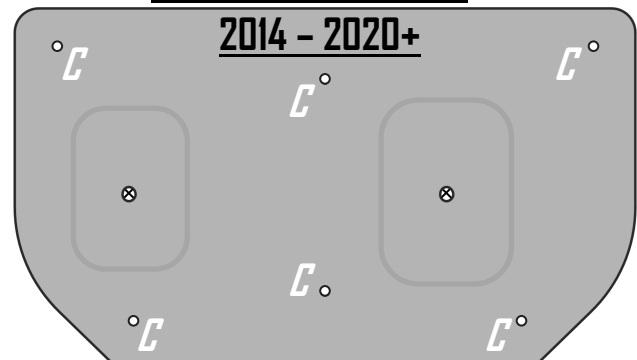

Swing Arm Guard

2014 - 2020+





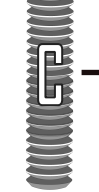
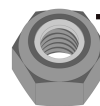



Polaris RZR 170 (2012-2018+) Hardware kit

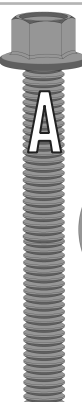

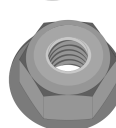
#1 Front Diff. Large bag :

-  1x 1" x 1" "D" Clamps (#C-D:2)
-  2x 1" x 1 1/4" "D" Clamps (#C-D:3)
-  3x 1/4"-20 x 1 1/4" Counter Sunk Bolts (#B-C:2)
-  3x 1/4"-20 Ny-Lock Nut (#N:2)
-  3x 1/4" Gold Washers (#W:3)

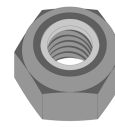

#2 Main Skid Large bag :

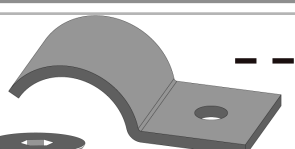
-  8x MG- 1.0 x 45mm Flange Bolt (#B-A:10)
-  8x Counter Sunk Washers (#W:1)
-  8x 1/4" Silver Zinc Washers (#W:4)
-  8x MG- 1.0 Flange Nut (#N:1)
-  4x 1" x 1 1/4" "D" Clamps (#C-D:3)
-  4x 1/4"-20 x 1" Counter Sunk Bolts (#B-C:1)
-  4x 1/4" Gold Washers (#W-3)
-  4x 1/4"-20 Ny-Lock Nut (#N:2)

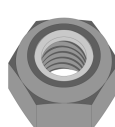
-13 Swing Arm Guard large bag : (2009 – 2013)

-  3x 1" x 1" "D" Clamps (#C-D:2)
-  5x 1/4"-20 x 1" Counter Sunk Bolts (#B-C:1)
-  5x 1/4" Gold Washers (#W-3)
-  5x 1/4"-20 Ny-Lock Nut (#N:2)

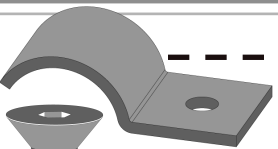
14+ Swing Arm Guard large bag : (2014 – 2020+)

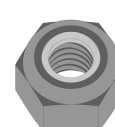
-  6x 1" x 1 1/4" "D" Clamps (#C-D:3)
-  6x 1/4"-20 x 1 1/4" Counter Sunk Bolts (#B-C:2)
-  6x 1/4" Gold Washers (#W-3)
-  4x 1/4"-20 Ny-Lock Nut (#N:2)