



International Filter Products

Revolutionary systems for your industry

SKV Series PES 0.45µm/0.2µm – Dual Layer Filter Capsules

SKV Series Dual Layer PES filter capsule with all polypropylene construction provides excellent chemical compatibility and superior flow per unit area as compared to other membrane capsules. The PES filter capsules have been specially designed for sterilizing in biopharmaceutical applications. The filters come with pre layer configuration, which increases the filtration volume significantly (up to 25%). The hydrophilic PES membrane does not require pre-wetting agents, thereby eliminating a potential source of contamination. The PES membrane is a low protein binding media. The units are used for filtration of small to medium volumes used in production, laboratory, and pilot runs. No adhesives, binders, or surfactants are used in the manufacturing process of these capsules. The filters are manufactured in accordance with GMP and comply with <USP 797> guidelines. The filters are flushed with pharmaceutical-grade purified pyrogens-free water, and 100% integrity tested prior to dispatch. Our filters are free from animal-derived components raw materials can be traced by Lot Number and strictly regulated maintaining ISO 13485 & ISO 14001 quality standards.

SKV Mid-Size Filter Capsules with various Inlet/Outlet Connections

Medium Capsules

SKV-H
1/2" Hose Barb
Filtration Area: 720 cm²

SKV-S
1 1/2" Tri-Clamp
Filtration Area: 1,380 cm²

SKV-L
1/2" Hose Barb
Filtration Area: 2,600 cm²

SKV-K
1/2" Hose Barb
Filtration Area: 5,200 cm²

Phone: (818) 504-8115
Cell: (818) 917-9538
E-mail: sales@internationalfilterproducts.com

Application

- Buffers and Media
- SVP (Small Volume Parenteral)
- Vaccines
- Scale up processing
- Product Sterilization
- Bio Bags Compatible
- Biologics
- Ultrapure Water
- Fermentation Broths
- Pharmaceuticals
- Antibiotics
- Serums



International Filter Products

Revolutionary systems for your industry

www.internationalfilterproducts.com
11070 Fleetwood St. Unit B
Sun Valley, CA 91352
Tel: (818) 504-8115 - Office
Tel: (818) 917-9538 - Cell
E-mail: sales@internationalfilterproducts.com



International Filter Products

Revolutionary systems for your industry

Technical Data Sheet

Micron Rating:

Final Membrane: 0.2 μm PES [Sterilizing Grade Membrane]

Pre-Filter: Highly Asymmetric 0.45 μm PES

Effective Filtration Area:

H-Size; 0.73 ft^2 , (680 cm^2)

S-Size; 1.35 ft^2 , (1,250 cm^2)

L-Size; 2.74 ft^2 , (2,550 cm^2)

E-Size; 4.13 ft^2 , (3,840 cm^2)

K-Size; 5.47 ft^2 , (5,080 cm^2)

Materials of Construction:

Membrane: Pharmaceutical Grade PES (Polyethersulfone) Sterilizing Grade

Membrane Feature: Hydrophilic, Low Protein Binding, High Flow Rate

Shell, Cage, Core, End Caps: Polypropylene

Valve O-Rings: Silicone (Standard)

Sealing: Thermally Bonded

Operating Conditions:

Maximum Forward Differential Pressure: **Liquid:** 5.5 bar (80psi) at 77°F/25°C

Gas: 4.1 bar (60psi) at 77°F/25°C

Minimum Burst Pressure: 8.3 bar (120psi) at 77°F/25°C

Maximum Reverse Differential Pressure: 3.0 bar (44psi) at 68°F/20°C

Maximum Operating Temperature: 176°F/80°C



International Filter Products

Revolutionary systems for your industry

www.internationalfilterproducts.com

11070 Fleetwood St. Unit B

Sun Valley, CA 91352

Tel: (818) 504-8115 - Office

Tel: (818) 917-9538 - Cell

E-mail: sales@internationalfilterproducts.com



International Filter Products

Revolutionary systems for your industry

Nominal Dimension:

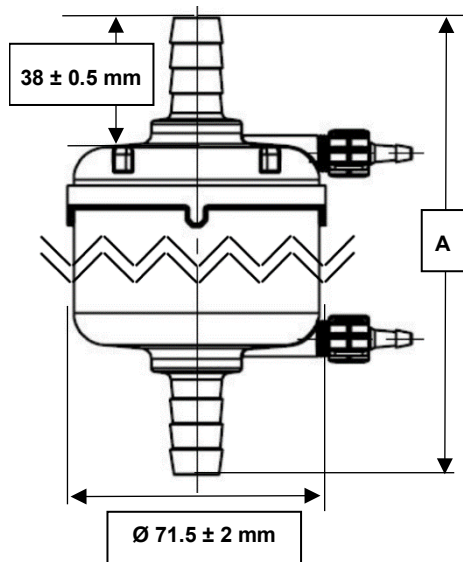

**4H4H
Connections**

Part Number	Internal Filter Length (inches)	Inlet	Outlet	Vent / Drain	Overall Length [A] (± 2 mm)
SKVDS45S020 H 4H4H-ETO	1.5"	½" Hose Barb	½" Hose Barb	1/8" Vent Valve	127 mm
SKVDS45S020 S 4H4H-ETO	2.5"	½" Hose Barb	½" Hose Barb	1/8" Vent Valve	155 mm
SKVDS45S020 L 4H4H-ETO	5.0"	½" Hose Barb	½" Hose Barb	1/8" Vent Valve	212 mm
SKVDS45S020 E 4H4H-ETO	7.5"	½" Hose Barb	½" Hose Barb	1/8" Vent Valve	276 mm
SKVDS45S020 K 4H4H-ETO	10.0"	½" Hose Barb	½" Hose Barb	1/8" Vent Valve	340 mm

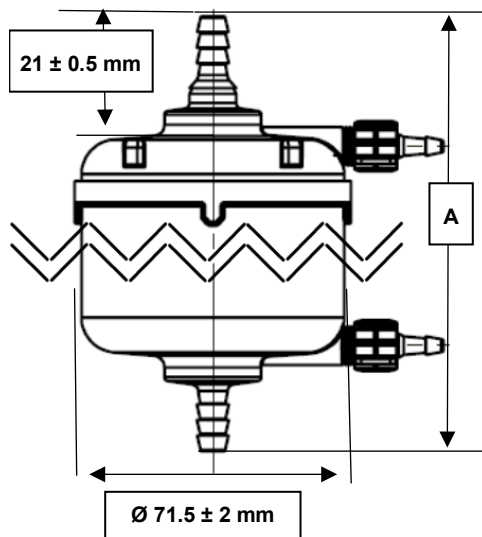

**3H3H
Connections**

Part Number	Internal Filter Length (inches)	Inlet	Outlet	Vent / Drain	Overall Length [A] (± 2 mm)
SKVDS45S020 H 3H3H-ETO	1.5"	3/8" Hose Barb	3/8" Hose Barb	1/8" Vent Valve	120 mm
SKVDS45S020 S 3H3H-ETO	2.5"	3/8" Hose Barb	3/8" Hose Barb	1/8" Vent Valve	148 mm
SKVDS45S020 L 3H3H-ETO	5.0"	3/8" Hose Barb	3/8" Hose Barb	1/8" Vent Valve	205 mm
SKVDS45S020 E 3H3H-ETO	7.5"	3/8" Hose Barb	3/8" Hose Barb	1/8" Vent Valve	269 mm
SKVDS45S020 K 3H3H-ETO	10.0"	3/8" Hose Barb	3/8" Hose Barb	1/8" Vent Valve	333 mm



International Filter Products

Revolutionary systems for your industry

www.internationalfilterproducts.com

11070 Fleetwood St. Unit B

Sun Valley, CA 91352

Tel: (818) 504-8115 - Office

Tel: (818) 917-9538 - Cell

E-mail: sales@internationalfilterproducts.com



International Filter Products

Revolutionary systems for your industry

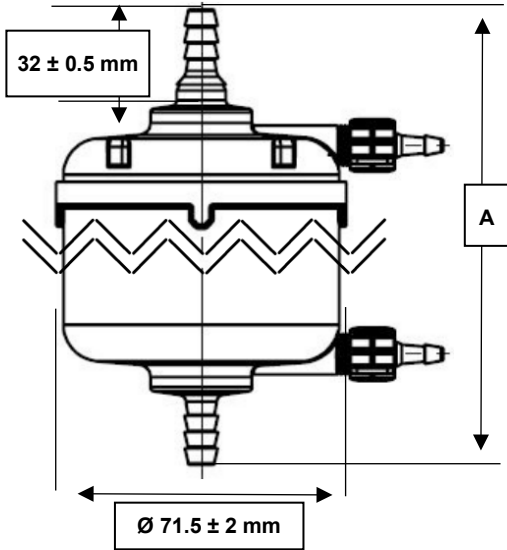

**2H2H
Connections**

Part Number	Internal Filter Length (inches)	Inlet	Outlet	Vent / Drain	Overall Length [A] (± 2 mm)
SKVDS45S020 H 2H2H-ETO	1.5"	¼" Hose Barb	¼" Hose Barb	1/8" Vent Valve	112 mm
SKVDS45S020 S 2H2H-ETO	2.5"	¼" Hose Barb	¼" Hose Barb	1/8" Vent Valve	140 mm
SKVDS45S020 L 2H2H-ETO	5.0"	¼" Hose Barb	¼" Hose Barb	1/8" Vent Valve	197 mm

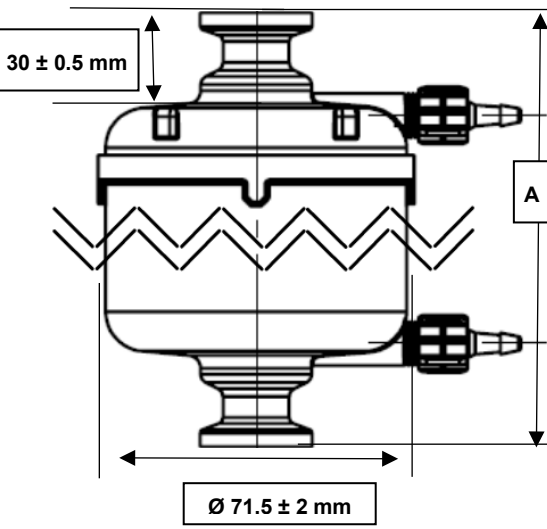

**MTMT
Connections**

Part Number	Internal Filter Length (inches)	Inlet	Outlet	Vent / Drain	Overall Length [A] (± 2 mm)
SKVDS45S020 H MTMT-ETO	1.5"	0.5" Tri-Clamp	0.5" Tri-Clamp	1/8" Vent Valve	98 mm
SKVDS45S020 S MTMT-ETO	2.5"	0.5" Tri-Clamp	0.5" Tri-Clamp	1/8" Vent Valve	126 mm
SKVDS45S020 L MTMT-ETO	5.0"	0.5" Tri-Clamp	0.5" Tri-Clamp	1/8" Vent Valve	183 mm
SKVDS45S020 E MTMT-ETO	7.5"	0.5" Tri-Clamp	0.5" Tri-Clamp	1/8" Vent Valve	247 mm
SKVDS45S020 K MTMT-ETO	10.0"	0.5" Tri-Clamp	0.5" Tri-Clamp	1/8" Vent Valve	311 mm



International Filter Products

Revolutionary systems for your industry

www.internationalfilterproducts.com
 11070 Fleetwood St. Unit B
 Sun Valley, CA 91352
 Tel: (818) 504-8115 - Office
 Tel: (818) 917-9538 - Cell
 E-mail: sales@internationalfilterproducts.com



International Filter Products

Revolutionary systems for your industry

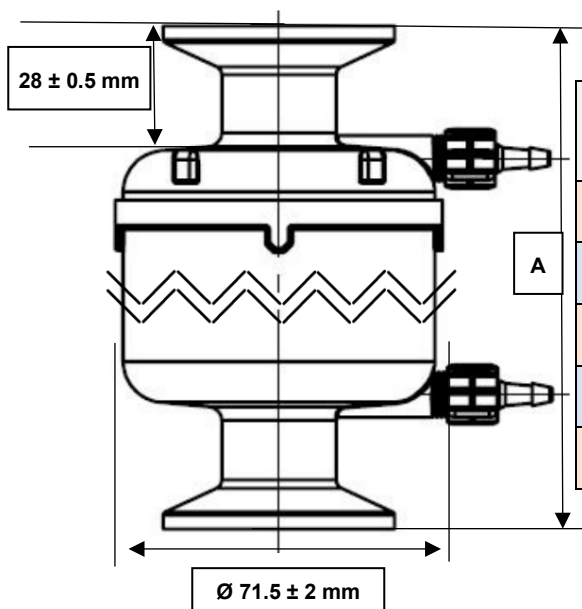

Part Number	Internal Filter Length (inches)	Inlet	Outlet	Vent / Drain	Overall Length [A] (± 2 mm)
SKVDS45S020 H TCTC-ETO	1.5"	1-1/2" Tri-Clamp	1-1/2" Tri-Clamp	1/8" Vent Valve	110 mm
SKVDS45S020 S TCTC-ETO	2.5"	1-1/2" Tri-Clamp	1-1/2" Tri-Clamp	1/8" Vent Valve	138 mm
SKVDS45S020 L TCTC-ETO	5.0"	1-1/2" Tri-Clamp	1-1/2" Tri-Clamp	1/8" Vent Valve	195 mm
SKVDS45S020 E TCTC-ETO	7.5"	1-1/2" Tri-Clamp	1-1/2" Tri-Clamp	1/8" Vent Valve	259 mm
SKVDS45S020 K TCTC-ETO	10.0"	1-1/2" Tri-Clamp	1-1/2" Tri-Clamp	1/8" Vent Valve	323 mm

**TCTC
Connections**

Typical Filtered Volume:

Filter Size	Filter Area	Volume to be Filtered (Thru-Put in Liters)
SKV-H	680 cm^2	17.5 to 40
SKV-S	1250 cm^2	25 to 60
SKV-L	2550 cm^2	40 to 120
SKV-E	3840 cm^2	60 to 175
SKV-K	5080 cm^2	90 to 220

*Volume Filtered is an estimated range for Pharmaceutical & Biological applications. The Filtration Volume is significantly influenced by your solution's viscosity, active ingredients, etc., properties. The best way to determine the exact filtration volume per filter is to try it with your solution.



International Filter Products
Revolutionary systems for your industry

www.internationalfilterproducts.com
11070 Fleetwood St. Unit B
Sun Valley, CA 91352
Tel: (818) 504-8115 - Office
Tel: (818) 917-9538 - Cell
E-mail: sales@internationalfilterproducts.com



International Filter Products

Revolutionary systems for your industry

Filter Integrity:

The finished product was sampled and shown to exhibit a minimum bubble point of ≥ 18 psi (1.2 bar) in 60%IPA / 40% water and ≥ 50 psi (3.5 bar) in DI Water (at 22°C).

Sterilization:

International Filter Products Inc. mostly stocks ETO Sterilized (Factory Sterilized) Filter Capsules.

Ethylene Oxide (ETO) Sterilization Process complies with ISO 10993-7:2008 Biological Evaluation of Medical Devices - Part 7. Each filter is subjected to a validated ETO process. Sterilization of the fluid path has been validated per ANSI/AAMI/ISO 11135 which provides a minimum sterility assurance level (SAL) of 10^{-6} .

Capsules can be autoclaved 25 times at 125 °C (257°F) for 30 minutes or chemically sanitized in situ using common sanitizing agents or hot water at 90 °C (194°F) for a limited time (dependent on time and temperature).

Warning: The filters cannot be sterilized by steam-in-place (SIP)

Regulatory Compliance:

The filters are constructed with polypropylene resins and filtration media in compliance with 21CFR Part 177 of the US Code of Federal Regulations and USP Class VI Biological Test for Plastic.

USP Bacterial Endotoxins:

The filters were tested to confirm that an aqueous extraction of this product contains <0.25 EU/ml as determined by the Limulus Amebocyte Lysate (LAL) Test

USP Conductivity:

Effluent is tested during the manufacturing process and shown to meet the requirements for USP Sterile Water for Injection for conductivity.



International Filter Products
Revolutionary systems for your industry

www.internationalfilterproducts.com
11070 Fleetwood St. Unit B
Sun Valley, CA 91352
Tel: (818) 504-8115 - Office
Tel: (818) 917-9538 - Cell
E-mail: sales@internationalfilterproducts.com



International Filter Products

Revolutionary systems for your industry

Bacterial Retention:

The filters are quantitatively retentive towards *Brevundimonas diminuta* (ATCC #19146) at a minimum challenge level of 10^7 CFU per cm^2 of filtration area, consistent with ASTM F838-05

ISO 10993-5 Cytotoxicity:

Extract from this product is non-Cytotoxic

ASTM Hemolysis:

Extract from this product is non-Hemolytic

Human and Veterinarian Use:

The product is safe for Human and Veterinarian use. CGMP CFR part 210 & 211, additional requirement of 21 CFR part 600 and 21 CFR part 680 are applicable to the aseptic manufacturing process.

Animal-Derived Components & TSE/BSE Risk:

No animal-derived material is intentionally added or used during the manufacture of this product.

Shelf Life:

The SKV capsules have a shelf life of 3 years from the date of sterilization.

Ethylene Oxide (ETO) Sterilized product packaging provides adequate protection to maintain a sterile barrier throughout the distribution, handling, and 3-year shelf life of the product.



International Filter Products

Revolutionary systems for your industry

www.internationalfilterproducts.com

11070 Fleetwood St. Unit B

Sun Valley, CA 91352

Tel: (818) 504-8115 - Office

Tel: (818) 917-9538 - Cell

E-mail: sales@internationalfilterproducts.com



SKV - Series PES Mid-Size Capsules

(Pharmaceutical Grade)

Ordering Guide



[1]	[2]	[3] Inlet and [4] Outlet	[5]
Micron Rating [Pre-Filter/Final Filter]	Filter Size Code [Filtration Area]	Inlet and Outlet Connection	Sterilization
<ul style="list-style-type: none"> • S020 : 0.2 µm • DS065S020 : Highly Asymmetric 0.65/0.2 µm • DS045S020 : Highly Asymmetric 0.45/0.2 µm • DS045S010 : Highly Asymmetric 0.45/0.1 µm • S080020 : 0.8/0.2 µm • S020010: 0.2/0.1 µm <p>Note: All final membranes are sterilizing grade.</p>	<ul style="list-style-type: none"> • H [Filtration Area: 720 cm²] • S [Filtration Area: 1380 cm²] • L [Filtration Area: 2600 cm²] • E [Filtration Area: 3980 cm²] • K [Filtration Area: 5200 cm²] 	<ul style="list-style-type: none"> • 1H : 1/8" Hose Barb • 2H : 1/4" Hose Barb • 3H : 3/8" Hose Barb • 4H : 1/2" Hose Barb • 5H : 9/16" Hose Barb • MT : 1/2" Tri-Clamp • TC : 1 1/2" Tri-Clamp 	<p>-ETO Ethylene Oxide Sterilization</p>

Example:

SKVDS045S020S4H4H-ETO

PureFlo SKV Series Capsule, Highly Asymmetric Dual Layer PES 0.45µm / 0.2µm PES membrane (Sterilizing Grade), 2.5", S-Size, Filtration Area 1,250 cm², 1/2" Hose Barb (Inlet/Outlet), ETO Sterilized (Factory Sterilized)

Part Number

Description





International Filter Products

Revolutionary systems for your industry

Special Configuration:

Layer Option:

- Single Layer
- Dual Layer

Micron Rating Option:

- 0.04 Micron
- 0.1 Micron
- 0.2 Micron
- 0.45 Micron
- 0.65 Micron
- 0.8 Micron
- 1.2 Micron

Bleed Valve Seal Option:

- Silicone
- EPDM
- Nitrile
- Viton

Inlet Fitting Option:

- 1H = 1/8" Hose Barb
- 1Q = 1/8" Male Quick Coupling with Metal Latch
- 2H = 1/4" Hose Barbs
- 2HS = 1/4" to 3/8 " Hose Barb
- 2Q = 1/4" Male Quick Coupling for Metal Latch
- 3H = 3/8" Hose Barb
- 4H = 1/2" Hose Barb
- 4Q = 1/2" Male Quick Coupling for Plastic latch
- 5H = 5/8" Hose Barb
- MT = 1/2" Tri clamps
- TC = 1-1/2" Tri clamp

Outlet Fitting Option:

- 1H = 1/8" Hose Barb
- 1Q = 1/8" Male Quick Coupling with Metal Latch
- 2H = 1/4" Hose Barbs
- 2HS = 1/4" to 3/8 " Hose Barb
- 2Q = 1/4" Male Quick Coupling for Metal Latch
- 3H = 3/8" Hose Barb
- 4H = 1/2" Hose Barb
- 4Q = 1/2" Male Quick Coupling for Plastic latch
- 5H = 5/8" Hose Barb
- MT = 1/2" Tri clamps
- TC = 1-1/2" Tri clamp



International Filter Products

Revolutionary systems for your industry

www.internationalfilterproducts.com

11070 Fleetwood St. Unit B

Sun Valley, CA 91352

Tel: (818) 504-8115 - Office

Tel: (818) 917-9538 - Cell

E-mail: sales@internationalfilterproducts.com