



# International Filter Products

*Revolutionary systems for your industry*

## PureFlo® D65R Series PTFE 1.0µm/0.2µm – Dual Layer Disc Filters

The PureFlo® D65R Hydrophobic PTFE Filter Discs (65mm diameter) are expertly engineered for specialized filtration applications, including Oil-Based Solutions, Hormones, Alcohol-Based Solutions, Testosterone, and DMSO in laboratory, pilot, and small-scale settings, particularly in the pharmaceutical and biotechnological industries. These hydrophobic PTFE membrane filters are ideal for handling these specific applications, providing exceptional chemical resistance and minimizing extractables, which is crucial for maintaining the purity and integrity of sensitive compounds. The built-in pre-filter protects the final filter, which increases its lifespan by 10%-20%. Adhering to strict GMP guidelines and <USP 797> standards, the filters are manufactured without adhesives or binders and are thermally sealed to ensure performance integrity. Each unit undergoes comprehensive integrity testing. Compliance with ISO 13485 & ISO 14001 quality standards and the absence of animal-derived components ensure the highest quality and safety standards.

### PureFlo® D65R Disc Filters with various Inlet/Outlet Connections



**LFLF Connections**

**Inlet:**

Luer Lock Female

**Outlet:**

Luer Lock Female

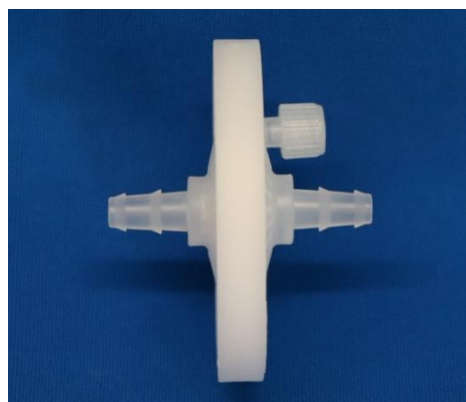

**2H2H Connections**

**Inlet:**

1/4"-5/16" Hose Barb

**Outlet:**

1/4"-5/16" Hose Barb



**LFLM Connections**

**Inlet:**

Luer Lock Female

**Outlet:**

Luer Lock Male



**International Filter Products**  
*Revolutionary systems for your industry*



7914 Ajay Drive, Sun Valley, CA 91352  
www.internationalfilterproducts.com  
sales@internationalfilterproducts.com  
Phone: (818) 504-8115



# International Filter Products

*Revolutionary systems for your industry*

## Application

- Oil Base Solution
- Testosterone
- DMSO
- Low Flow Filtration
- Hormones
- Bio Bags Compatible
- Biologics
- Product Sterilization
- Alcohol Base Solution
- Pharmaceuticals
- Ketones
- Organic Solvent

## Technical Data Sheet

### Micron Rating:

**Final Membrane:** 0.2  $\mu\text{m}$  PTFE [Sterilizing Grade Membrane]

**Pre-Filter:** 1.0  $\mu\text{m}$  PTFE

### Effective Filtration Area:

D65R Series; 4  $\text{in}^2$  (26  $\text{cm}^2$ )

### Materials of Construction:

Membrane: Pharmaceutical Grade PTFE (Polytetrafluoroethylene) Sterilizing Grade

Membrane Feature: Hydrophobic, Low Protein Binding, High Flow Rate

Shell, Cage, Core, End Caps: Polypropylene

Sealing: Thermally Bonded

### Operating Conditions:

Maximum Forward Differential Pressure: **Liquid:** 5.5 bar (80psi) at 72°F/22°C

**Gas:** 4.1 bar (60psi) at 72°F/22°C

Minimum Burst Pressure: 8.3 bar (120psi) at 72°F/22°C

Maximum Forward Differential Pressure: 4.1 bar (60psi) at 72°F/22°C

Maximum Reverse Differential Pressure: 2.1 bar (30psi) at 72°F/22°C

Maximum Operating Temperature: 176°F/80°C



**International Filter Products**  
*Revolutionary systems for your industry*



7914 Ajay Drive, Sun Valley, CA 91352  
[www.internationalfilterproducts.com](http://www.internationalfilterproducts.com)  
[sales@internationalfilterproducts.com](mailto:sales@internationalfilterproducts.com)  
Phone: (818) 504-8115



# International Filter Products

Revolutionary systems for your industry

## Nominal Dimension:

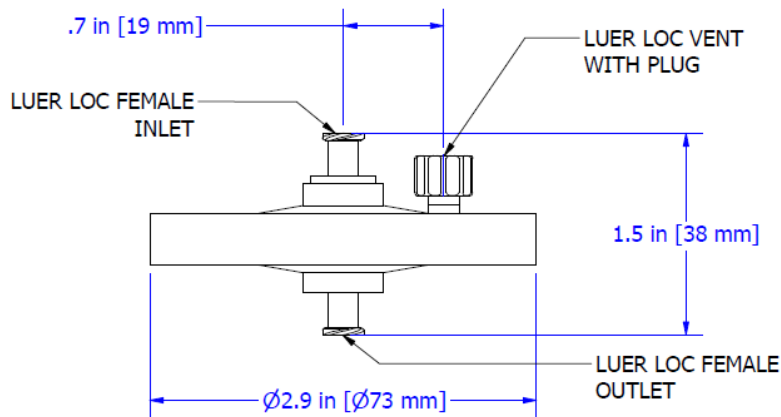

**LFLF Connections**

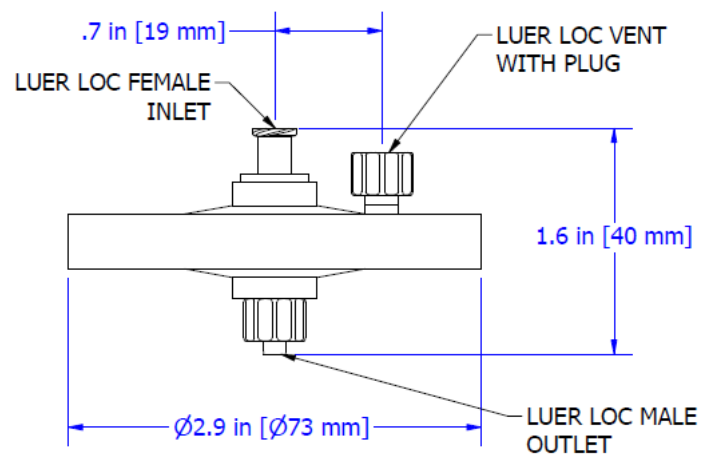

**LFLM Connections**

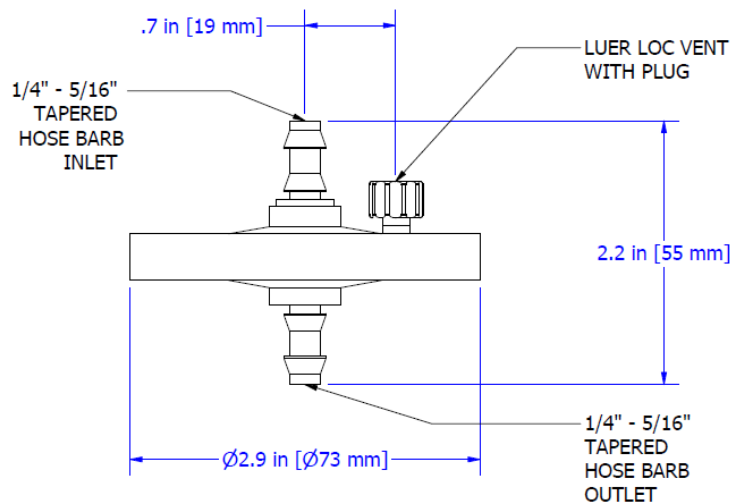

**2H2H Connections**





# International Filter Products

*Revolutionary systems for your industry*

## Typical Filtered Volume:

- 230ml-1,000ml [Oil base solution]
- 460ml – 1,880ml [Alcohol base solution]

\*Volume Filtered is an estimated range for Sterile Compounding, Pharmaceutical & Biological applications. The Filtration Volume is significantly influenced by your solution's viscosity, active ingredients, etc., properties. The best way to determine the exact filtration volume per filter is to try it with your solution.

## Filter Integrity:

The finished product was sampled and shown to exhibit a minimum bubble point of  $\geq 17.5$  psi (1.2 bar) in 70%IPA / 40% water (at 22°C).

## Bacterial Retention ASTM F838-05:

The filters are quantitatively retentive towards *Brevundimonas diminuta* (ATCC #19146) at a minimum challenge level of  $10^7$  CFU per  $cm^2$  of filtration area, consistent with ASTM F838-05

## Sterilization:

International Filter Products Inc. mostly stocks ETO Sterilized (Factory Sterilized) Filter Discs.

Ethylene Oxide (ETO) Sterilization Process complies with ISO 10993-7:2008 Biological Evaluation of Medical Devices - Part 7. Each filter is subjected to a validated ETO process. Sterilization of the fluid path has been validated per ANSI/AAMI/ISO 11135 which provides a minimum sterility assurance level (SAL) of  $10^{-6}$ .

Discs can be autoclaved 25 times at 125 °C (257°F) for 30 minutes or chemically sanitized in situ using common sanitizing agents or hot water at 90 °C (194°F) for a limited time (dependent on time and temperature).

*Warning:* The filters cannot be sterilized by steam-in-place (SIP)



**International Filter Products**  
*Revolutionary systems for your industry*



7914 Ajay Drive, Sun Valley, CA 91352  
www.internationalfilterproducts.com  
sales@internationalfilterproducts.com  
Phone: (818) 504-8115



# International Filter Products

*Revolutionary systems for your industry*

## Regulatory Information

### Regulatory Compliance 21CFR Part 177 & USP <88>:

The filters are constructed with polypropylene resins and filtration media in compliance with 21CFR Part 177 of the US Code of Federal Regulations and USP Class VI Biological USP <88>Test for Plastic.

### USP <85> Bacterial Endotoxins:

The filters were tested to confirm that an aqueous extraction of this product contains <0.25 EU/ml as determined by the Limulus Amebocyte Lysate (LAL) Test

### USP <645> Conductivity USP:

Effluent is tested during the manufacturing process and shown to meet the requirements for USP Sterile Water for Injection for conductivity.

### USP <87> / ISO 10993-5 Cytotoxicity:

Extract from this product is non-Cytotoxic.

### Hemolysis ASTM F756-17:

Extract from this product is non-Hemolytic.

### Human and Veterinarian Use:

The product is safe for Human and Veterinarian use. CGMP CFR part 210 & 211, the additional requirement of 21 CFR part 600 and 21 CFR part 680 are applicable to the aseptic manufacturing process.

### Animal-Derived Components & TSE/BSE Risk:

No animal-derived material is intentionally added or used during the manufacture of this product.

### Shelf Life:

The D65R Discs have a shelf life of 3 years from the date of sterilization.

Ethylene Oxide (ETO) Sterilized product packaging provides adequate protection to maintain a sterile barrier throughout the product's distribution, handling, and 3-year shelf life.



# International Filter Products

Revolutionary systems for your industry

## D65R - Series PTFE Disc Filter (Pharmaceutical Grade)

### Ordering Guide

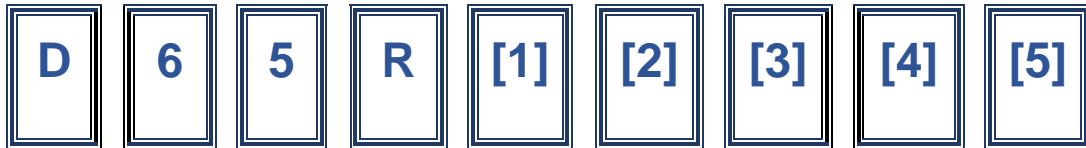

[1]	[2] Inlet and [3] Outlet	[4]	[5]
Micron Rating [Pre-Filter/Final Filter]	Inlet and Outlet Connection	Grade	Sterilization
<ul style="list-style-type: none"> <li>F020 : 0.2 µm</li> <li>F100020 : 1.0/0.2 µm</li> </ul> Note: All final membranes are sterilizing grade.	<ul style="list-style-type: none"> <li>2H : 1/4"-5/16" Hose Barbs</li> <li>LF : Luer Loc Female</li> <li>LM : Luer Loc Male</li> </ul>	-PH Pharmaceutical Grade	-ETO Ethylene Oxide Sterilization

### Example:

**D65RF100020FLM-PH-ETO**

PureFlo® D65R Series Disc Filter, Dual Layer 1.0µm / 0.2µm PTFE membrane (Sterilizing Grade), Filtration Area 26 cm<sup>2</sup>, Luer Loc Female Inlet and Luer Loc Male Outlet, Pharmaceutical Grade (PH), ETO Sterilized (Factory Sterilized)

Part Number

Description



International Filter Products  
Revolutionary systems for your industry



7914 Ajay Drive, Sun Valley, CA 91352  
www.internationalfilterproducts.com  
sales@internationalfilterproducts.com  
Phone: (818) 504-8115



# International Filter Products

*Revolutionary systems for your industry*

## Special Configuration:

### Layer Option:

- Single Layer
- Dual Layer

### Micron Rating Option:

- 0.1 Micron
- 0.2 Micron
- 0.45 Micron
- 1.0 Micron

### Inlet Fitting Option:

- 1H : 1/8" Hose Barb
- 1Q : 1/8" Male Quick Coupling with Metal Latch
- 2H : 1/4" Hose Barbs
- 2H-FB : 1/4" Hose barbs with Filling Bell
- 2Q : 1/4" Male Quick Coupling for Metal Latch
- 2N : 1/4" MNPT
- 3H : 3/8" Hose Barbs
- LF : Luer Loc Female
- MT : 1/2" Tri clamps

### Outlet Fitting Option:

- 1H : 1/8" Hose Barb
- 1Q : 1/8" Male Quick Coupling with Metal Latch
- 2H : 1/4" Hose Barbs
- 2H-FB : 1/4" Hose barbs with Filling Bell
- 2Q : 1/4" Male Quick Coupling for Metal Latch
- 2N : 1/4" MNPT
- 3H : 3/8" Hose Barbs
- LM : Luer Loc Male
- MT : 1/2" Tri clamps



**International Filter Products**  
*Revolutionary systems for your industry*



7914 Ajay Drive, Sun Valley, CA 91352  
[www.internationalfilterproducts.com](http://www.internationalfilterproducts.com)  
[sales@internationalfilterproducts.com](mailto:sales@internationalfilterproducts.com)  
Phone: (818) 504-8115