

Series SSSH:

Sanitary Stainless-Steel Housings

FOOD AND BEVERAGE

INTRODUCTION

Our Sanitary Single Element Housings are designed for high-purity applications and to meet your critical processing needs.

These housings are commonly used in the Food and Beverage industries. Housings exceed standards for sterile filtration. The 316L Stainless Steel housings have been designed to meet ASME BPE. The highly polished corrosive-resistant material is ideal because of its superior strength and chemical compatibility.

The housings can accept one 2.75 diameter 226 O-ring filter configuration of various lengths. The 226 connection guarantees proper sealing preventing fluid bypass. Housings are designed for complete disassembly, allowing full access to all internal surfaces for easy cleaning. No special tools are required to open and close the housing due to it being sealed by a Tri-clamp

FEATURES

- *Aseptic Design*
- *Electro-Polished*
- *Cartridge Stop*
- *Maximize Product Recovery*
- *Easy to use low point drain valve*



APPLICATIONS

- *Beverages*
- *Chemical*
- *High Purity Water*

BENEFITS:

- *No Dead Legs*
- *Fully Self draining*
- *Seamless of filter change-out*
- *Removable for Cleanability*
- *Maximize Product Recovery*
- *Crevice Free Electropolished surfaces with 16 RA internal surfaces*

Series SSSH

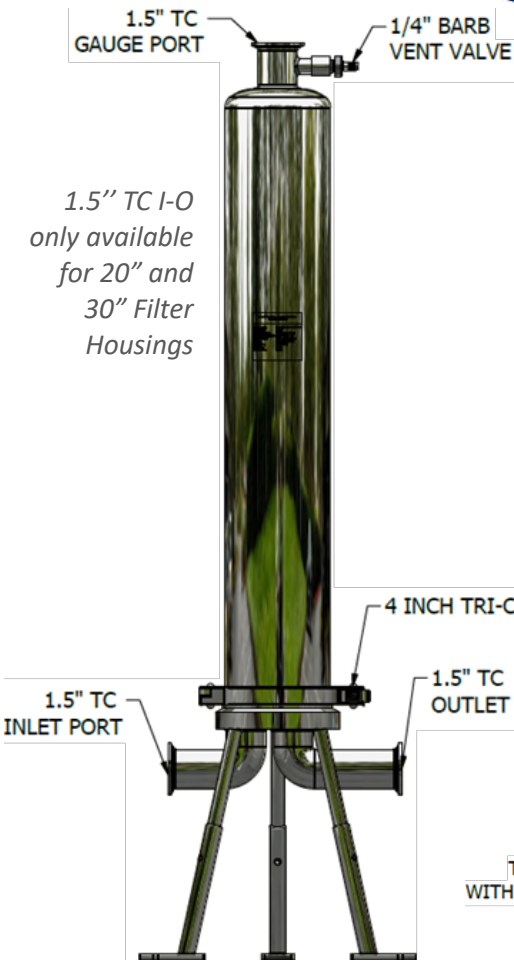

1.5" TC I-O
only available
for 20" and
30" Filter
Housings

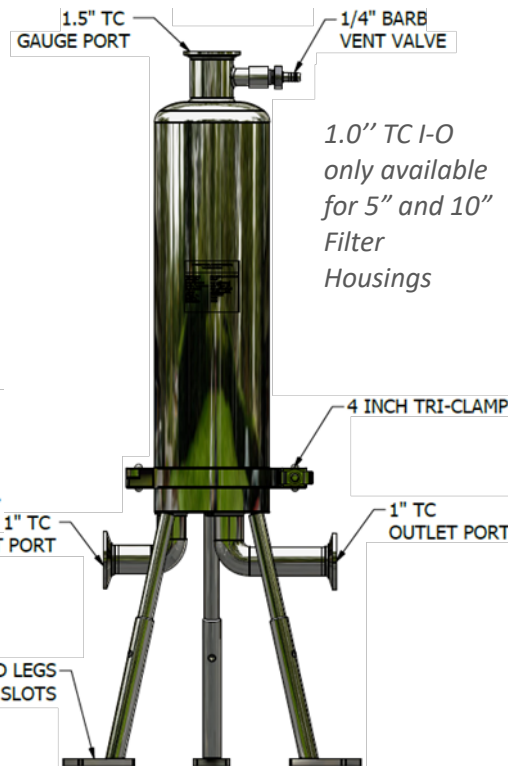

1.0" TC I-O
only available
for 5" and 10"
Filter
Housings

External Design Features - IFP's Sanitary Single Element Filter Housing is an aseptic design that is simple and convenient. The tri-clamp that fixes the dome to the base provides simplicity when filter changes or inspecting filter housing seals are required. The housing base has tabbed legs which provide stability and the option of fixing the housing onto a platform (see Single-Element Housing Duplex System Literature). The filter housing was designed for easy venting with a barb vent.

As shown in the photos, the external design feature of our single-element filter housings.

Internal Design Features - The objective of our Engineers was to design filter housing that is aseptic and convenient to use. Once the tri-clamp is removed the user can remove the lightweight dome, accessing the internal components. At the base, there is a 226 Cartridge slot with Lock tabs. This connection secures the filter into place and provides a tight seal preventing contaminate bypass.

As shown in the photos, the internal design feature of our single-element filter housings

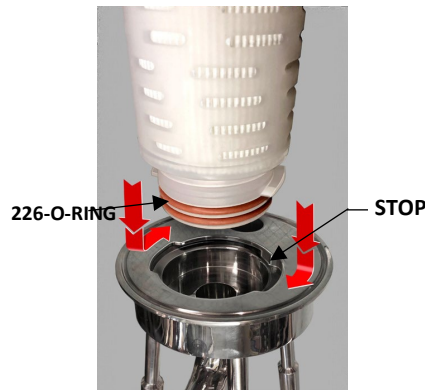
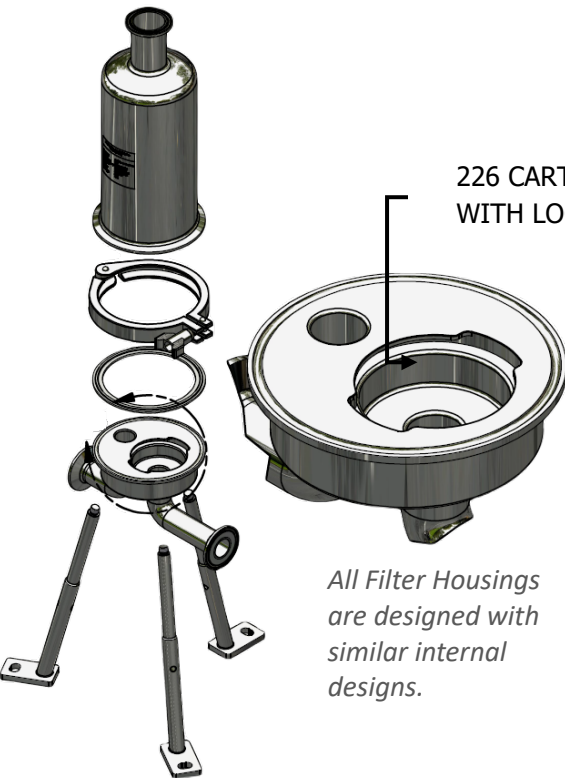

All Filter Housings
are designed with
similar internal
designs.

Series SSSH

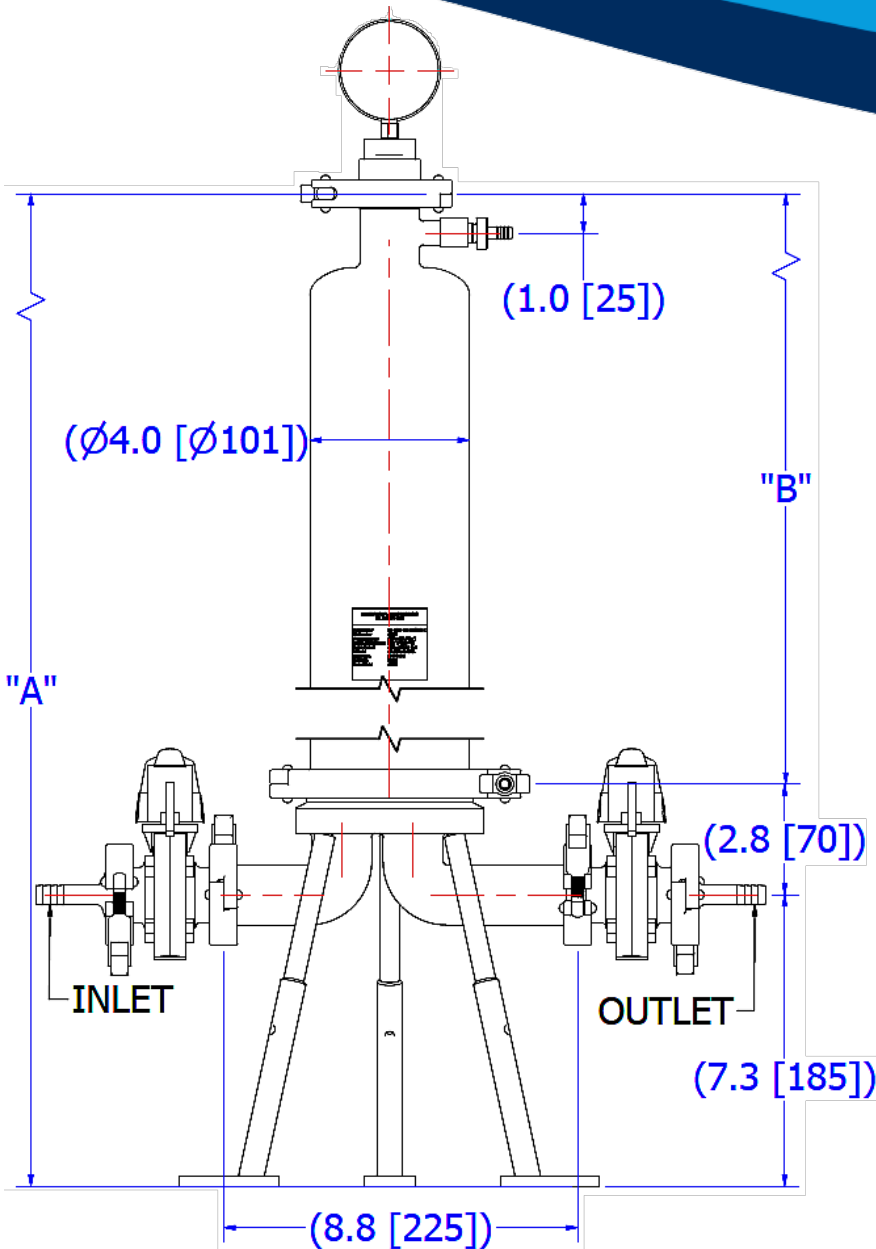

Materials of Construction:

Head: 316L Stainless Steel
 Bowl: 316L Stainless Steel
 Clamp: 304 Stainless Steel
 Legs: 304 Stainless Steel
 Vent: 316L Stainless Steel
 O-Rings: Silicone, EPDM, Buna N, or Kalrez

Cartridge Dimensions (nominal)

Lengths (in): 5", 10", 20", 30"

Connections:

Inlet/ Outlet: 1.0" Sanitary Flange (5" & 10")
 1.5" Sanitary Flange (20" & 30")
 Gauge Port; 1.5" Sanitary Flange
 Vent: 1/4" valve w hose barb

Finish:

Internal Surfaces: Electro-Polished < 16 RA
 External Surfaces: Electro-Polished < 25 RA

Operating Conditions:

Max Operating Pressure, 125 PSI (10 Bar)
 @212 °F (100 °C)

Cleaned & Packaged:

Cleaned per specification NAS 1638, Class 5
 on a Class 100 flow bench and packaged.

Element Length	"A"	"B"
5.0"	20.3 in (517 mm)	10.3 in (262 mm)
10.0"	24.9 in (632 mm)	14.9 in (378 mm)
20.0"	34.9 in (887 mm)	24.9 in (632 mm)
30.0"	44.9 in (1141 mm)	34.9 in (887 mm)

NOMENCLATURE

PART NUMBER EXAMPLE: 01-0210-1-1-226-1

Style	Element Length	Inlet/Outlet	O-Ring	Vent/Drain
XX-XXXX	-X	-X	-XXX	-X
01-0210	A = 5.0"	1 = 1.0" TC	226=226	1 = 1/4" Valve
01-0210	1 = 10.0"	1 = 1.0" TC	226=226	1 = 1/4" Valve
01-0210	2 = 20.0"	2 = 1.5" TC	226=226	1 = 1/4" Valve
01-0210	3 = 30.0"	2 = 1.5" TC	226=226	1 = 1/4" Valve

PRESSURE VS. FLOW RATE (PES MEMBRANE & POLYPROPYLENE)

