

# 500KG

## HYDRAYLIC TRACKED DUMPER

### SAFETY AND OPERATION INSTRUCTIONS

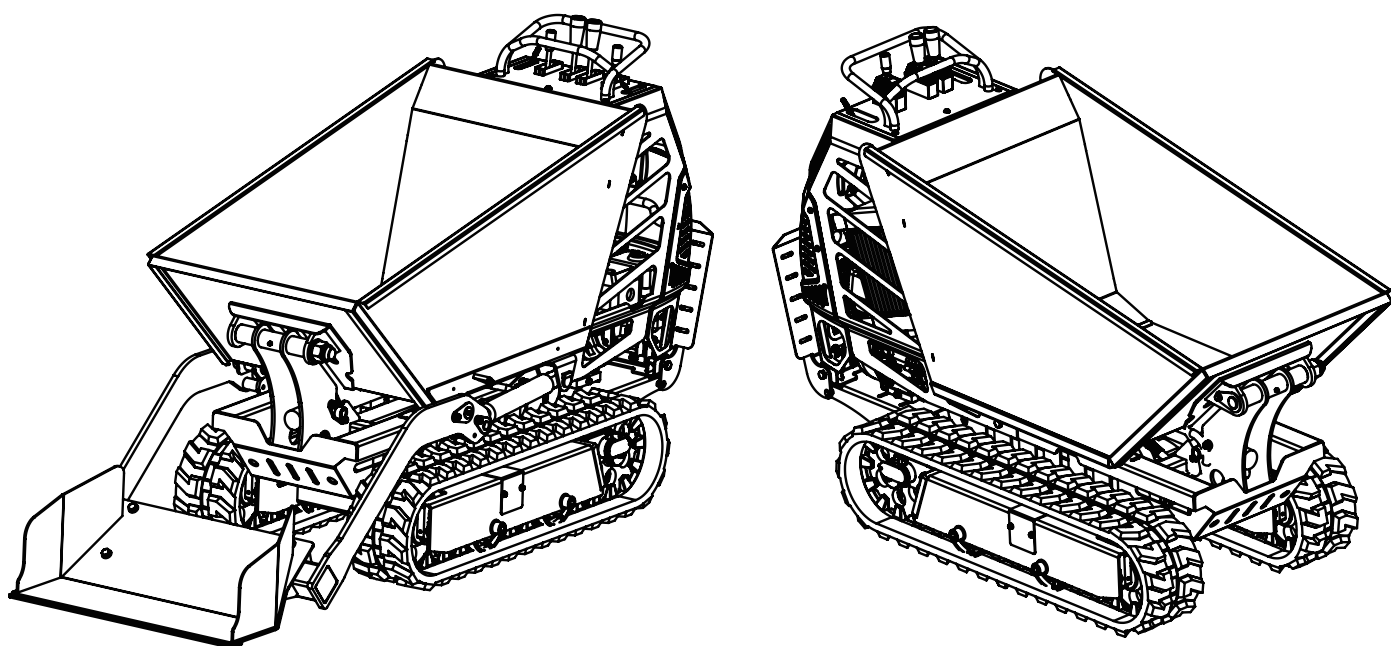

This manual should always be readily available so that the machine operator may consult it immediately, and it must be saved for the entire duration of the machine's life.

The entire or partial reproduction and/or divulging of this document is prohibited in any form without the written consent of the manufacturing company. The editing of the text, the illustrations, and the paginations were realized by manufacturer. The information and technical data were furnished, checked and validated by manufacturer. The illustrations and technical data included in this manual are non binding: the manufacturer reserves the right to carry out eventual modifications to its product without notice.

**FOR YOUR SAFETY READ AND UNDERSTAND THE ENTIRE MANUAL BEFORE OPERATING THIS MACHINE**



# Contents

## GENERAL INFORMATION

- INTRODUCTION.....1
- FORMALITY OF GUARANTEE.....1
- GOAL OF THE MANUAL .....1
- MACHINE DESCRIPTION.....2
- TECHNICAL CHARACTERISTICS AND DRAWING.....3
- SAFETY INFORMATION.....4
- SAFETY LABELS FOUND ON YOUR UNIT.....6
- ADMISSIBLE SLOPES.....9
- DIMENSIONS.....9

## COMMANDS

- DRIVE LEVER.....11
- DOUBLE SPEED VERSION.....11
- SELF-LOADING VERSION.....11

## INSTRUCTION FOR USE

- FIRST USE.....12
- BREADING-IN PERIOD.....12
- STARTTING THE ENGINE.....12
- REFUELLING.....13
- DRIVING THE MACHINE.....13
- DRIVING POSITION.....14
- FORWARD GEAR.....15
- REVERSE GEAR.....15
- TRAVELLING ON SLOPES.....16
- STOPPING MOVEMENT.....16
- MOVEMENT IN CRUVES.....16
- COUNTER ROTATION.....16
- STOPPING AND PARKING.....17
- TRANSPORT LOADING.....18
- UNLOADING MATERIAL.....18
- TRANSPORT.....18
- STORAGE.....19

## MAINTENANCE

- ORDINARY AND EXTRAORDINARY MAINTENANCE.....19

## TROUBLESHOOTING TABLE.....21

---

---

# PART I: GENERAL INFORMATION

## INTRODUCTION

The following manual is turned to the personnel that has the responsibility of the correct use of the machines it regards the safety aspects. You recommends therefore a careful reading, especially of the paragraphs related to the instructions and to the formalities of use, to possibly preserve him/it in his/her custody together with the machine, so that to assure its availability for the following consultations. The machines provided of devices and safety systems opportunely studied and tested. The supplier is not taken on any responsibility in the case of tampering, substitution e/o any other change that changes the anticipated operation of the car.

## FORMALITY OF GUARANTEE

The guarantee of the machine is valid for 1 year from the date of sale and has value on the products mechanics and voters not of consumption.

They are excluded by the guarantee the products of consumption as tools, rubber tracks, liquids and oils.

Any defect in particular that was not caused by the manufacturer, parts used in/on terrain surfaces, and breakdowns caused by incompetence or carelessness, including fueling, are excluded from the guarantee.

The motor is covered under the manufacturer of the motor's own warranty according to the foreseen conditions and terms.

The guarantee immediately expires if the machine is utilized for uses different from those foreseen by the manufacturer, if it is damaged by the use of unauthorized accessories or if it is repaired using unsuitable parts.

With the machine a certificate of warranty was supplied which outlines the norms which regulate the service of assistance under warranty. We highly recommend reading the warranty form to fully understand the various rights and responsibilities. Collaborate with your sales representative when filling out the form and make sure it is filled out correctly, in that the text and the other formalities (shipment within the time limit, etc.) represent the legal base for the warranty on the machine.

## GOAL OF THE MANUAL

This manual has been drawn up by the manufacturer and is an integral part of the machine.

The information contained herewithin is addressed to expert operators, equipped with specific knowledge and competence in the sector of use. The manual defines the objectives for which the machine was designed and constructed.

To avoid incorrect manoeuvres that risk accident, it is important to read this manual particularly before the first use to familiarize oneself with the principal commands and their functions.

---

---

A constant observance of the information guarantees safety, economy of use, and a longer function duration of the machine.

To give a higher prominence to the sections of the text which must not be ignored, they have been highlighted in bold and preceded with symbols illustrated and defined following here:



**READ CAREFULLY:** Invites a careful and scrupulous reading of the manual before carrying out the operations described.



**DANGER:** Indicate imminently dangerous situations that can provoke serious injury or death if the instructions are not followed. On the machine potential dangers have been indicated with a sticker characterized by a red band with white text.



**WARNING:** Indicates a potentially dangerous situation that can provoke serious injury or death if the instructions are not followed. On the machine the warnings are indicated with stickers characterized by an orange band with black text.



**CAUTION:** Indicates a potentially dangerous situation that can provoke injury or damage to the machine if the instructions are not followed. On the machine situations requiring caution are indicated by stickers characterized by a yellow band with black text.



**PROHIBITED:** Prohibitions that must be observed by all persons who interact directly and/or indirectly with the machine so that risks may be limited.

## MACHINE DESCRIPTION

The 500kg hydraulic dumper are auto-unloading tracked vehicles that are compact and equipped with a body, designed and manufactured for the exclusive use of transporting inert materials or agricultural products, such as soil, manure, leaves, sand, grain and similar.

To satisfy the various requirements of the market, the machine may be equipped with motors that have similar power but that have different brand names and characteristics.

The main characteristic of this machine are: To be very simple, strong, reliable.

The small dimensions, the particularity of the loom, allows him to operate on every type of ground guaranteeing safety, stability and reliability in the time. A rapids verification to the morning will guarantee you a believer and sure companion of job for the whole day. The operating levers are situated in such a position that allows good visibility an any position and the operator it has the full control of the commands.

## TECHNICAL CHARACTERISTICS AND DRAWING

Description	WD50T	WD50TS	WD50TL
Engine	Single cylinder, four stroke, air cooling		
Displacement	212cc		
Net power	4.1kw/3600rpm		
Transmission	Fully hydraulic system		
Working pressure	16.5Mpa		
Driven type	Track		
Track width	180mm		
Track roller	4 pcs		
Track tensioning	Yes		
Hydraulic pump	Duplex gear pump	Triple gear pump	Duplex gear pump
Pump brand	Danfoss or Marzocchi		
Hydraulic motor	2 pcs		
Oil radiator	Yes		
Hydraulic oil tank	20.5L		
Loading capacity	500kgs		
Traveling speed	0-3.5km/h	Max Travel Speed: 0-3.5 KM/H (low speed version) 0-4.9 km/h (high speed version)	0-3.5km/h
Minimum ground clearance	100mm		
Minimum turning radius	850mm		
Track base	525mm		
Wheel base	345mm		
Overall length*width*height	1715*730*1160mm		
Package method	Plywood case		
Package size	1750*750*1200mm		
Gross weight	390kgs		
Loading quantity-20GP	9pcs		
Loading quantity-40HQ	38pcs		
Front loader	No	No	Yes

## SAFETY INFORMATION



**READ CAREFULLY:** The information contained here is essential for your safety and for that of your co-workers!

During the production of this machine, every possible measure was taken to make your work safer. Simple prudence, however, is essential: there is no better rule to prevent accidents.



**WARNING:** The machine must always be operated by a competent and well-trained operator.



Carefully read the information before using the machine or before performing maintenance and/or repairs.



A few minutes of your time spent reading this manual will save you time and effort.



Carefully read the warnings and information written on the signs on the machine and immediately substitute missing or illegible ones. Respect all regulations contained in these.



The machine was made exclusively for the transportation of inert materials. Any other use is prohibited.



**PROHIBITED:** It is strictly prohibited to use this machine for the transport of persons and/or animals.



**PROHIBITED:** It is strictly prohibited to use this machine to tow other machines, vehicles, and/or devices, not even temporarily or in an emergency situation.



The machine constitutes a work instrument: always respect the national regulations, especially those relative to safety at the place of work.



**REQUIRED:** Always wear suitable work clothes and above all suitable work shoes diligently. Always use protective hearing devices.



**WARNING:** Never wear large or fly-away clothes (scarves, ties) that could easily get caught in the moving parts.



It is always advisable to have a first kit close at hand.



Before turning on the motor, always be sure that there are not any people, animals, or things that could be an obstacle in the work area.





**DANGER:** Never use the machine inside enclosed areas because the gasses emitted by the exhaust are lethal.



**REQUIRED:** Carry out the disposal of oils, minerals, and harmful products with respect for the environment and in accordance with the current norms.

☞ Every intervention for cleaning, tuning, and/or maintenance must be done under good environmental conditions and with adequate light, and always with the motor turned off.



**DANGER:** Never refuel the vehicle when the motor is on or hot, in the proximity of flames or while smoking. Always keep the machine cleaned of lubricant and/or combustible residues.

☞ Pay careful attention to not come into contact with the overheated parts of the motor.



**PROHIBITED:** It is strictly prohibited to remove protection and safety devices with which the machine is equipped.

☞ Avoid working under unsuitable physical conditions or when you are very tired: in these cases interrupt your work.



**DANGER:** While working always be sure that the terrain has the required consistency and avoid working on the edge of embankments, ditches, or ravines or on excessively steep or uneven terrain.

☞ When putting away the machine take all precautions so that it might not be moved or turned on by incompetent or incapable persons.



**CAUTION:** Never leave the tool unattended while the motor is on, not even temporarily: when you leave the area, turn off the motor of the machine and put on the parking brake!



**DANGER:** Never let children play with the machine, not even if it is turned off!

## SAFETY LABELS FOUND ON YOUR UNIT



**READ CAREFULLY:** During the design phase everything possible was done to prevent eventual risks: where it was technically impossible, specific pictograms were resorted to in order to highlight eventual potential and imminent risks. Specific adhesive tags were made with signals and descriptions associated with pictograms to give a higher importance to possible dangers.



**PROHIBITED:** It is strictly prohibited to remove the stickers and the safety plates which the machine is equipped with: Immediately substitute deteriorated and/or illegible ones.

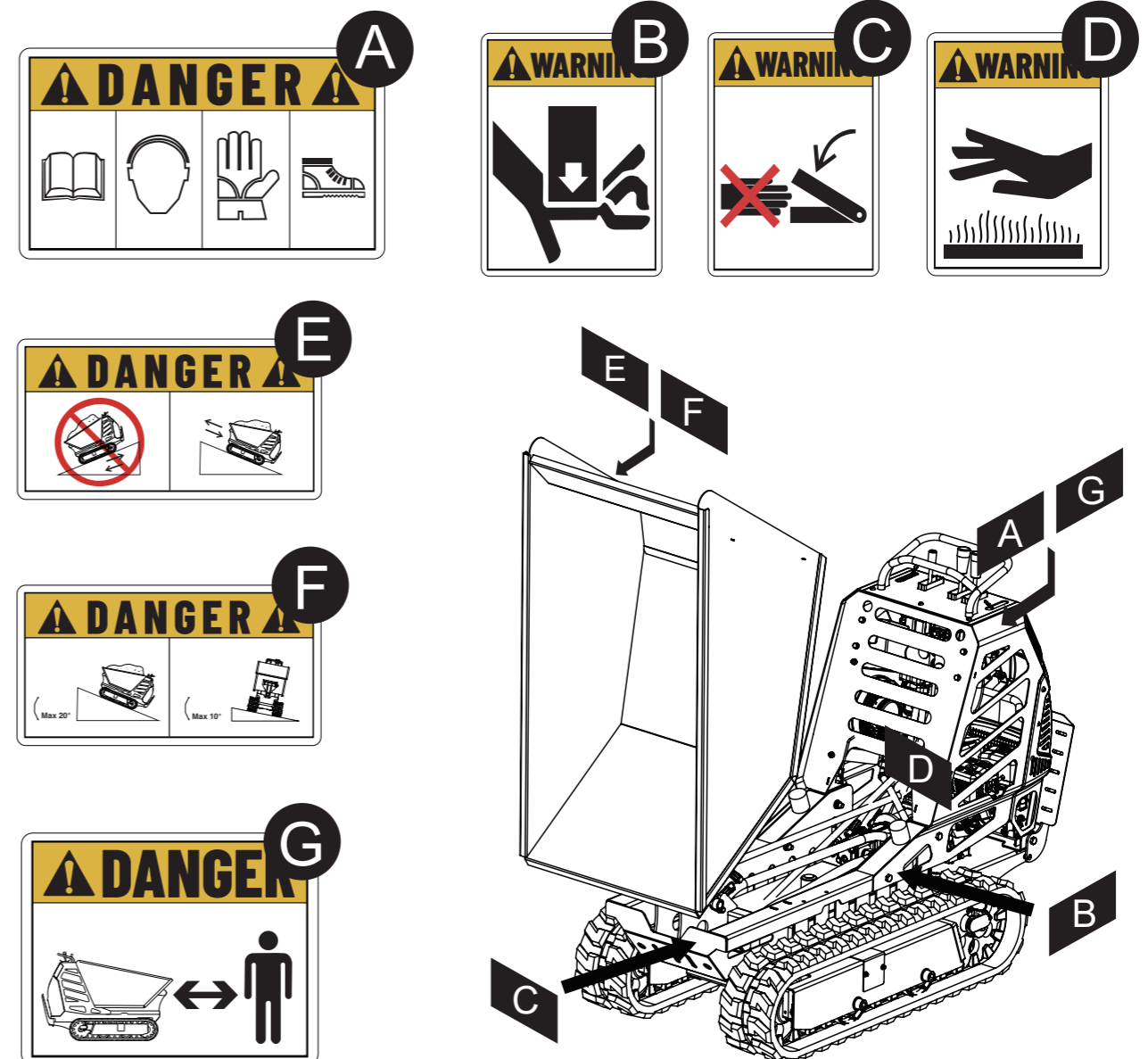

## Safety Distance

Tag which alerts the serious danger of coming near and standing within the field of action of the machine in that there is an imminent risk of danger.

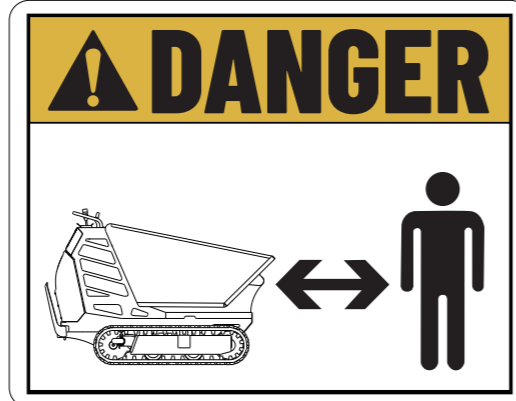

## Hot Surface

Invites caution in that there is a risk of burning because of the nearness to the hot surface.



## Crushing

Tags which indicate a potential risk of crushing that may cause very serious injury or death.



## Maximum slopes

Completely avoid working on terrains that have latitudinal slopes of more than  $10^\circ$  and longitudinal slopes of more than  $20^\circ$  to avoid the possibility of overturning with serious consequences for the safety of the operator. In every cases, but especially in the case of slopes, it is important that the terrain is solid and stable.

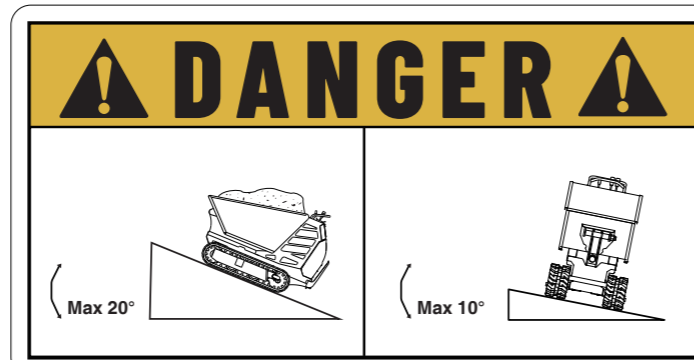

## Cutting

Tags which indicate a potential risk of cutting that may cause very serious injury and death.



## Upslope and downhill

The tag indicating the way for to avoid serious consequences to the user and the machine as there is a potential danger of tipping.

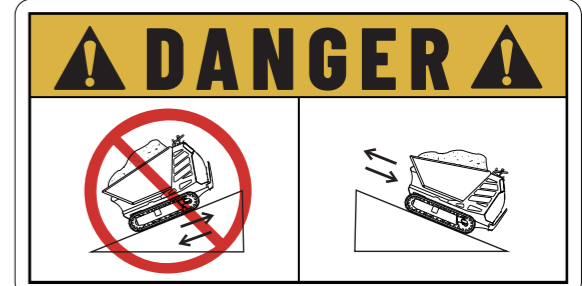

## Procedure for caution

This safety sticker that calls for caution remember to take all precautions accident prevention, especially regarding the use of protective equipment and individual prevention.

The meaning of the pictograms is the following:

- Wear safety shoes of the type prescribed.
- Wear hearing protection headsets or other devices prescribed type.
- Wear protective gloves of the type prescribed.
- Read the manual before running the machine the first time, each time changing the operator, and in all cases where there is a doubt on its operation.
- Do not remove the protections on the moving parts.
- Wear work cloths having the protections of the prescribed type.
- Do not adjust and/or remove and/or assembly parts during the running.

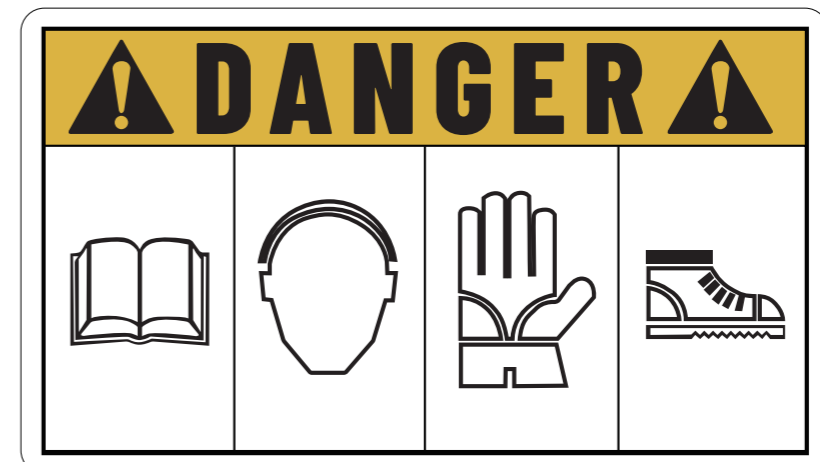

# ADMISSIBLE SLOPES

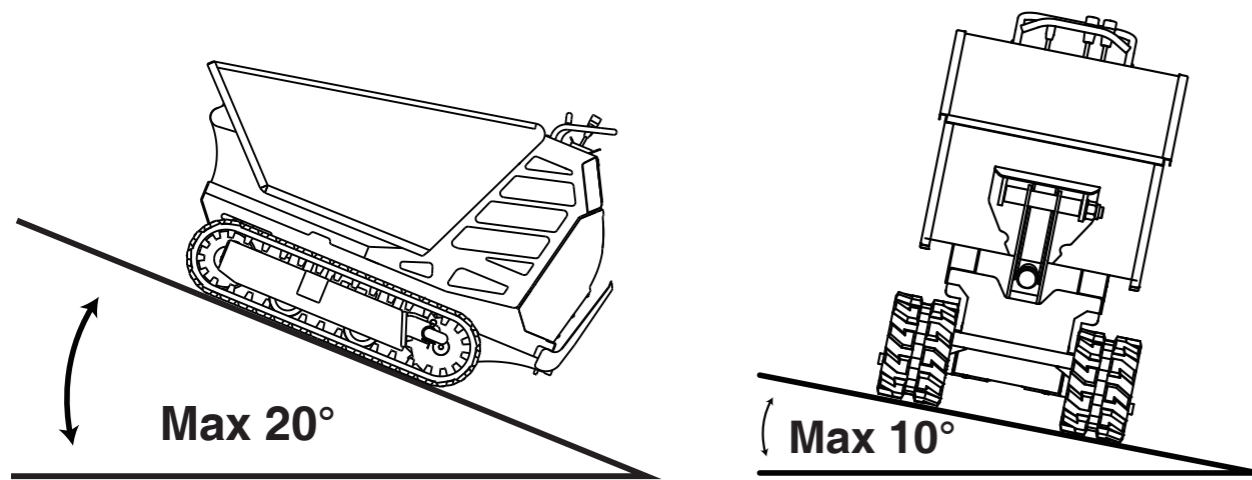

In figure the maximum values for the latitudinal and longitudinal slopes of the terrain are shown on which it is possible to work. These conditions must never be surpassed to avoid the risk of overturning.



**DANGER:** Always avoid working on terrain with slopes that are greater than those prescribed to avoid the possibility of overturning with possible serious consequences for the safety of the operator.

Always be sure that the terrain upon which you are working or travelling is solid and stable: avoid travelling on excessively soft and/or muddy terrain that can hide snares and throw the machine off balance, or on loose material that has accumulated that can shift under the weight of the machine.

# DIMENSIONS

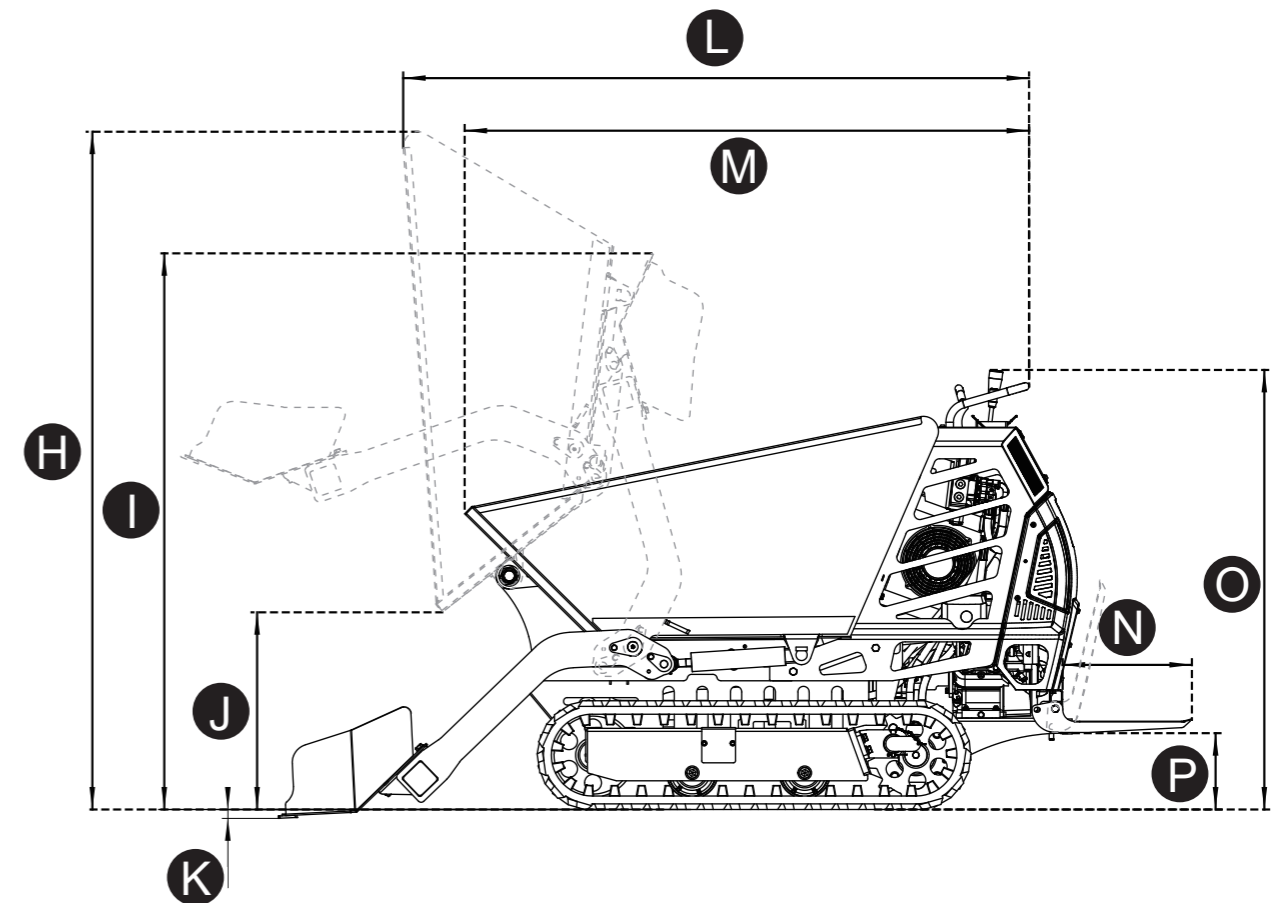
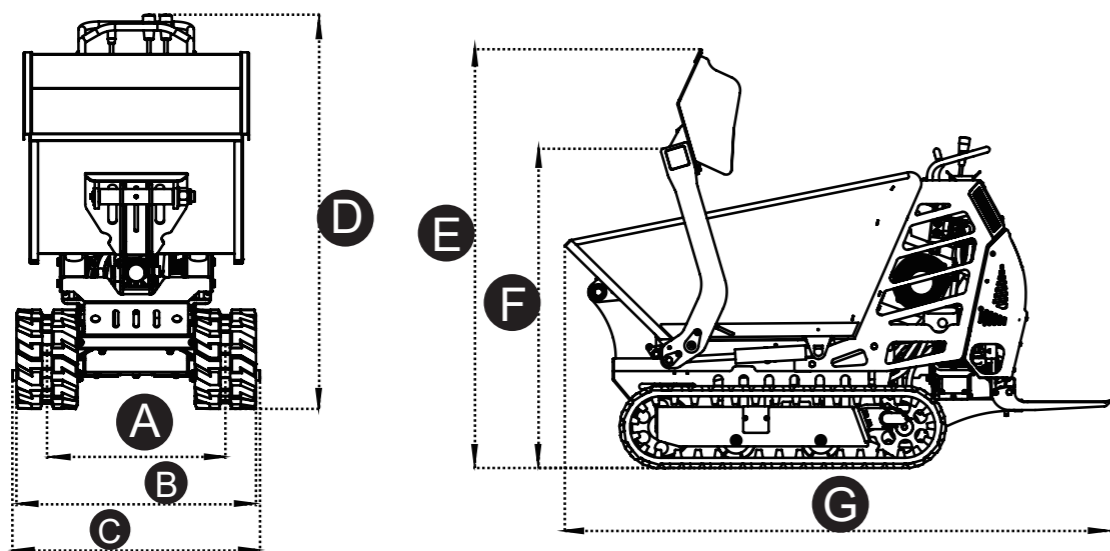

<b>A</b>	Wheel Track	525mm	<b>I</b>	Height	1484mm
<b>B</b>	Width	705mm	<b>J</b>	Height	526mm
<b>C</b>	Width	729mm	<b>K</b>	Height	24mm
<b>D</b>	Height	1160mm	<b>L</b>	Width	1670mm
<b>E</b>	Height	1485mm	<b>M</b>	Width	1506mm
<b>F</b>	Height	1132mm	<b>N</b>	Width	345mm
<b>G</b>	Length	1941mm	<b>O</b>	Height	1173mm
<b>H</b>	Height	1820mm	<b>P</b>	Height	204mm

## PART II:COMMANDS

### DRIVE LEVER

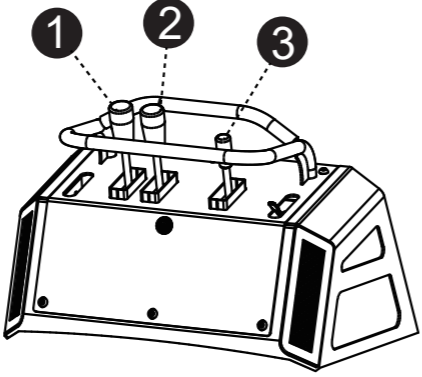
1	The left lever controls the left track.	
2	The right lever controls the right track.	
3	Skip bucket control lever.	

### DOUBLE SPEED VERSION

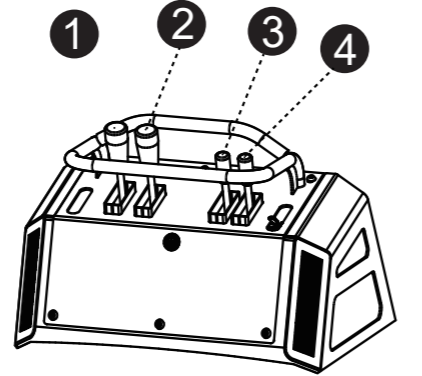
1	The left lever controls the left track.	
2	The right lever controls the right track.	
3	Skip bucket control lever.	
4	High and low speed switching lever, push lever is high speed.	

### SELF-LOADING VERSION

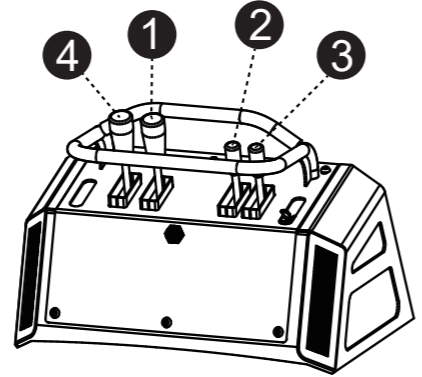
1	The left lever controls the left track.	
2	The right lever controls the right track.	
3	Skip bucket control lever.	
4	Front loading control lever.	

## PART III:INSTRUCTION FOR USE

### FIRST USE



**READ CAREFULLY:** Before using the machine you must read all of the instructions in this manual and the user's and maintenance manual of the motor installed on your machine scrupulously. Furthermore, always keep it attached to the machine.

The machine is normally delivered completely assembled and ready for use with an empty fuel tank. Fill the fuel tank, open the fuel tap and follow the start-up procedure described in the appropriate paragraph.

### BREADING-IN PERIOD

The technology used during the construction of your machine does not require a break in period. However, during the first period of use, it is necessary to use these precautions:



**READ CAREFULLY:** Read the user manual and the maintenance manual for the motor installed in your machine carefully and follow the instructions prescribed for its own break in period.

- ☞ During the first 50 hours, avoid using the motor at over 70% of the total power.
- ☞ After the first 20 hours of operation, check the level of the hydraulic oil in the tanks.
- ☞ During the first period of use, the tracks undergo an adjustment, for which it is necessary, after the first 50 hours of operation, to carry out the regulation of the tension of the tracks.

### STARTTING THE ENGINE



**WARNING:** Before turning on the engine, always insert the parking brake to avoid eventual movement of the machine that could present safety issues for the operator. Before you start up the engine, always verify the following indications scrupulously:

- ☞ Always start up the engine outside and be certain that there are no other persons in the vicinity of the machine and/or other impediments.
- ☞ Check that there is fuel in the tank.
- ☞ Always insert the parking brake.



☞ Follow the specific procedure prescribed by the constructor of the motor shown in the attached instructions.

## REFUELLING



**DANGER:** Refueling must always be done with the motor turned off! Do not smoke while refueling or while handling fuel to avoid the risk of fire!

The supply and/or transfer of fuel must always be performed outdoors, away from fire or heat sources. Always check that the fuel type is the one prescribed, specific to the engine of your machine.

- ☞ Place the machine on a clean surface.
- ☞ Unscrew the cap slowly.
- ☞ Fill the fuel in the tank slowly.
- ☞ Screw the cap tightly.
- ☞ Dry and fuel spills immediately.



**WARNING:** Do not fill with hot machine, wait 2 hours after turning off the engine before the refueling!



**WARNING:** Start the engine only after making sure that there are no traces of fuel spills accidentally!



**WARNING:** The conservation of fuel must be done while respecting the specific regulations, in suitable places, away from heat sources and in suitable containers thoroughly cleaned and closed!



**REQUIREMENT:** Avoid release to the environment fuels and/or containers, but please do so in an environmentally and local regulations.

## DRIVING THE MACHINE



**DANGER:** Always avoid overloading the machine above the prescribed limits: During movement, an overload could create structural variations that were not foreseen and could provoke the overturning of the machine with serious safety consequences.



**WARNING:** Where possible, try to avoid travelling on rocky or icy terrain, on rails and railway sections because they may damage the tracks and reduce their longevity. Also avoid passing over material that could ruin the tracks, such as sharp objects, pieces of metal, etc. That could get caught up in the tracks and provoke a break.

At the start up, regulate the number of rotations of the engine to the desired level by activating the throttle lever, according to the required power (when the machine is loaded, you must bring the lever above the halfway mark between minimum and maximum).

Under certain conditions, especially when the machine is loaded or going uphill, a loss of engine power may occur because of a motor overload; this may also cause it to shut down. In this case, slowly release the drive command lever, regulating the speed to a level that does not provoke an overload of the propeller.

Being a machine equipped with a hydraulic gear pump, it is not necessary that the rotations of the motor are at their maximum for the transfer. Leaving the engine operating at its maximum number of rotations does not improve the function of the machine, rather it certainly (an uselessly) increases its fuel consumption: it is advisable, therefore, to increase the rotations of the engine only where it is absolutely necessary (to proceed at maximum speed, to address steep slopes with a full load, etc.).

## DRIVING POSITION

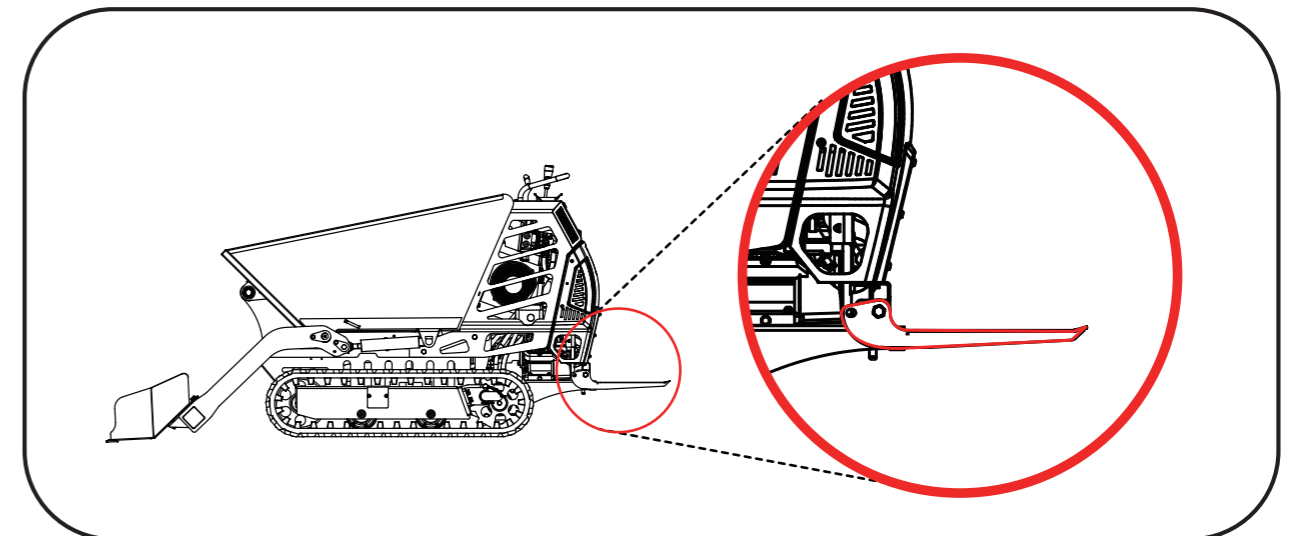

During the driving of the machine and during the work, is necessary utilize the footrest platform in open position to prevent risks.

Close the footrest platform only after use.



- ☞ Pull the safety pin spring that locks the platform.
- ☞ Turn the footrest to the horizontal position.
- ☞ Pay attention to the spring pin, make sure that it fits into the hole.



**DANGER:** Never drive with the footrest unblocked: Always verify that the footrest is blocked and that the safety pin is positioned correctly.



**WARNING:** When you open or close the footrest, be careful with your hands: You may cut yourself or crush them.

When the machine is in gear, always grasp the lever firmly with one hand and use the other hand simultaneously to activate both drive levers.

**NEVER RELEASE THE LEVER TO OPERATE THE COMMAND LEVERS WITH BOTH HANDS.**



**DANGER:** When the machine is in gear, the operator must always maintain the prescribed driving position.

## FORWARD GEAR

To allow the machine to advance one must activate both drive levers simultaneously by pushing them forward.

Avoid addressing downhill slopes in forward gear, refer to the paragraph "TRAVELING ON SLOPES".

## REVERSE GEAR

To allow the machine to back up you must activate both drive levers, pulling them back simultaneously.

Avoid addressing uphill slopes in reverse gear, especially with a loaded machine, rather follow the procedure described in the paragraph "TRAVELING ON SLOPES".



**DANGER:** While in reverse gear, always check to see that there are no obstacles and/or persons in the vicinity.

## TRAVELLING ON SLOPES

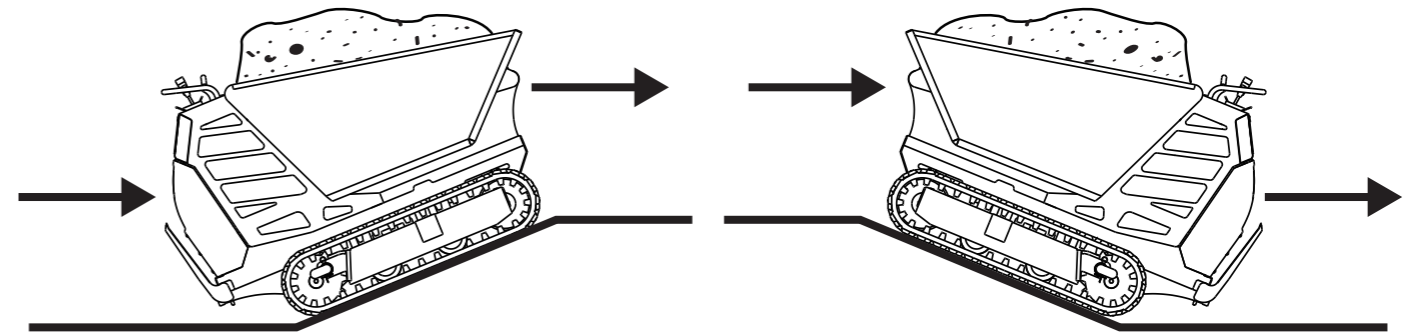

**DANGER:** Completely avoid working on terrains that have lateral slopes of more than 10° and longitudinal slopes of more than 20° to avoid the possibility of overturning with serious consequences for the safety of the operator.

When addressing sloped segments, especially when the machine is loaded, you must use this particular technique:

- ☞ Always address the uphill slopes in forward gear.
- ☞ Always address the downhill slopes in reverse gear.

## STOPPING MOVEMENT

To stop movement, must release the drive simultaneously.

## MOVEMENT IN CRUVES

To allow the machine to turn, must release the lever on the side to which one intends to turn:

- ☞ To turn to the right, release the right hand drive lever.
- ☞ To turn to the left, release the left hand drive lever.

The steering is determined by the slowing of the speed of one track with respect to the other.

## COUNTER ROTATION

It is also possible to make the machine spin round, carrying out a complete counter rotation around its axis, in order to carry out maneuver in small spaces

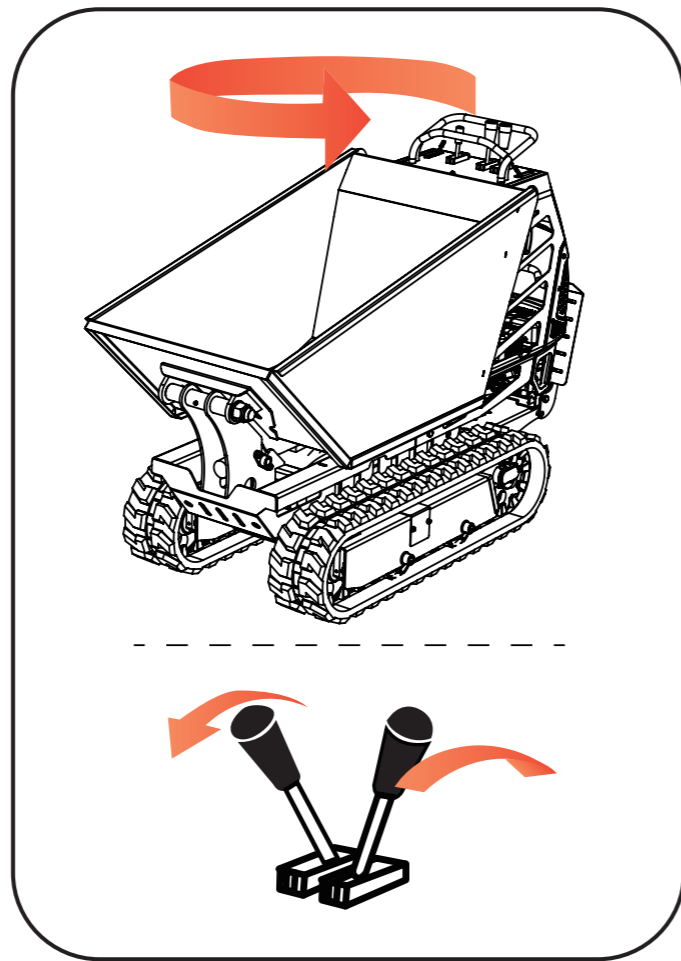
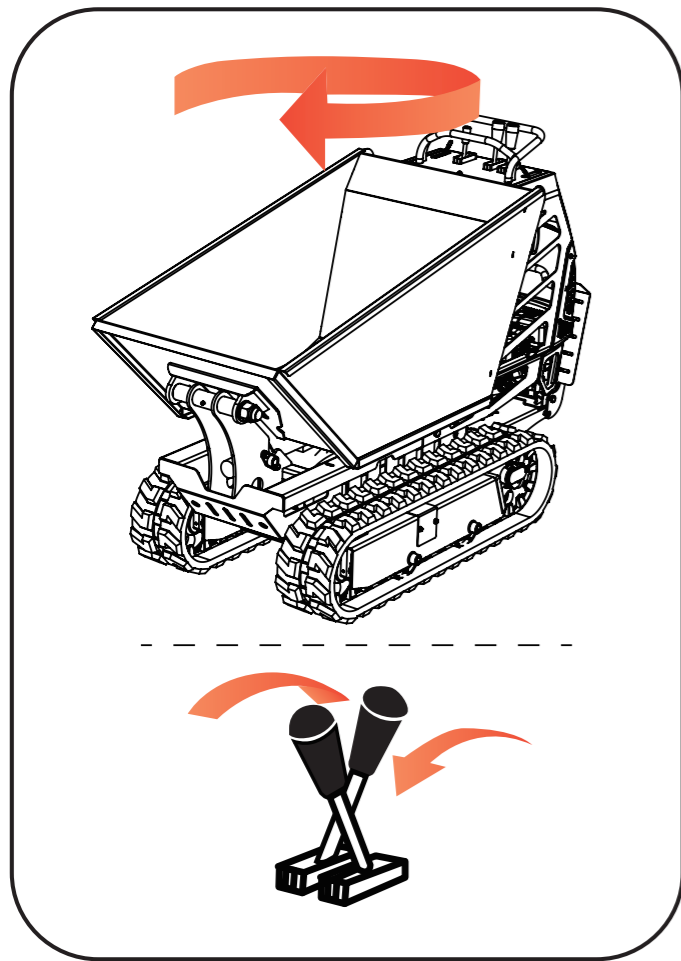

- ☞ To make a clockwise counter rotating (towards the direction of the clock hands) you must push the left hand lever forward and release the right hand lever.
- ☞ To make a counter-clockwise counter rotation (towards the opposite direction of clock hands) you must push the right hand lever forward and release the left hand lever.

## STOPPING AND PARKING



**WARNING:** If you move away from the machine and leave it unattended, always activate the parking brake and be sure that no unauthorized person may turn it on or more it. In the models which are equipped with one, always take out the engine cover key.

Before stopping the machine, it is preferable to position yourself on a flat paved surface, or on a flat and compact ground.

The machine is equipped manual parking brake, you must insert the brake to driving wheel.

## TRANSPORT LOADING



**PROHIBITED:** It is strictly prohibited to surpass the load capacity limits.

The machine is equipped with a dumper type body to transport inert and solid materials, suitable mainly to be used for construction work and farm work.

## UNLOADING MATERIAL



**WARNING:** Before unloading, be certain that the terrain is flat, solid and compact. Carry out the dumping maneuver slowly and uniformly. Do not move forward with the machine during the dumping phase.

Your machine is equipped with a hydraulic dumping device for the body which allows for the unloading of material.

- ☞ Position yourself on a level, solid, and compact surface or terrain.
- ☞ Push the dump lever forward to provoke the overturning and the unloading the material.
- ☞ Pull the dump lever back until the dumper has returned to travelling position, and then release the lever.



**CAUTION:** During the unloading, if the body hits up against an obstacle, avoid moving the machine forward: this could damage the junctions of the body!



**PROHIBITED:** It is strictly prohibited to travel if the body is not in its resting position.

## TRANSPORT



**WARNING:** During transport, always position the machine levelly to avoid the spilling of oil or other liquids.

If the machine needs to be transported, you must proceed correctly to avoid dangers to persons and/or to the machine, if there is any on the machine, keep down completely the bucket during the transport. Because of the weight of the machine, it is not possible to move it manually. Thus, it is necessary to use suitable means of lifting to load it onto a means of transport.

## STORAGE

Whenever the machine must remain inactive for several months, it is necessary to provide a correct garaging so that the machine is in perfect working order when it is used again.

In particular one must carry out storage by following all of these instructions ;

- ☞ Carry out all necessary repairs.
- ☞ Proceed with a careful cleaning and remove all mud, and/or organic residues carefully.
- ☞ Carry out a greasing of all points listed in the specific chapter.
- ☞ Place the machine in such a way that it is sheltered from atmospheric agents under stable conditions and on a flat surface.

When the machine back to service:

- ☞ Carry out all greasing again in all prescribed points found in the specific chapter.
- ☞ Proceed with the operations concerning the engine described in its own manual.
- ☞ Check the oil level and add some if necessary.

## PART IV: MAINTENANCE



**DANGER:** Always carry out all maintenance operations with the motor shut off.

Regular maintenance is essential to ensure the best performance and long life of your machine. In addition to regular maintenance on mechanical and plumbing, it is good practice to periodically clean the machine and carry out a thorough cleaning to remove the traces of mud. After each wash is necessary to grease all parts subject to friction.

## ORDINARY AND EXTRAORDINARY MAINTENANCE



**WARNING:** Before performing any maintenance procedure or inspection, shut off the engine, wait 30 minutes to allow all parts to cool.

To maintain the highest level of efficiency, and lengthen the life of the machine and in any case the guarantee is necessary that the maintenance is performed at regular intervals and programmed. Anyway presents a table showing all maintenance operations to be performed every 8 hours and any schedule of planned maintenance.

### Regular Maintenance Checklist

Procedure	Before each use	After Each use	Every 8 hours	Every 25 hours	Every 100 hours	Every 500 hours
Clean the machine		✓				
Engine oil	✓		✓			
Fuel	✓	✓				
Check Hydraulic oil loss	✓		✓			
Substitution hydraulic oil						✓
Check Air filter				✓		
Check Tracks tension	✓		✓			
Check Hydraulic pipe	✓	✓				
Greasing					✓	

### ENGINE SERVICE

Refer to the engine manufacturer's user manual for engine maintenance.

### TRACKS

Check and if necessary adjust the rubber track tension.

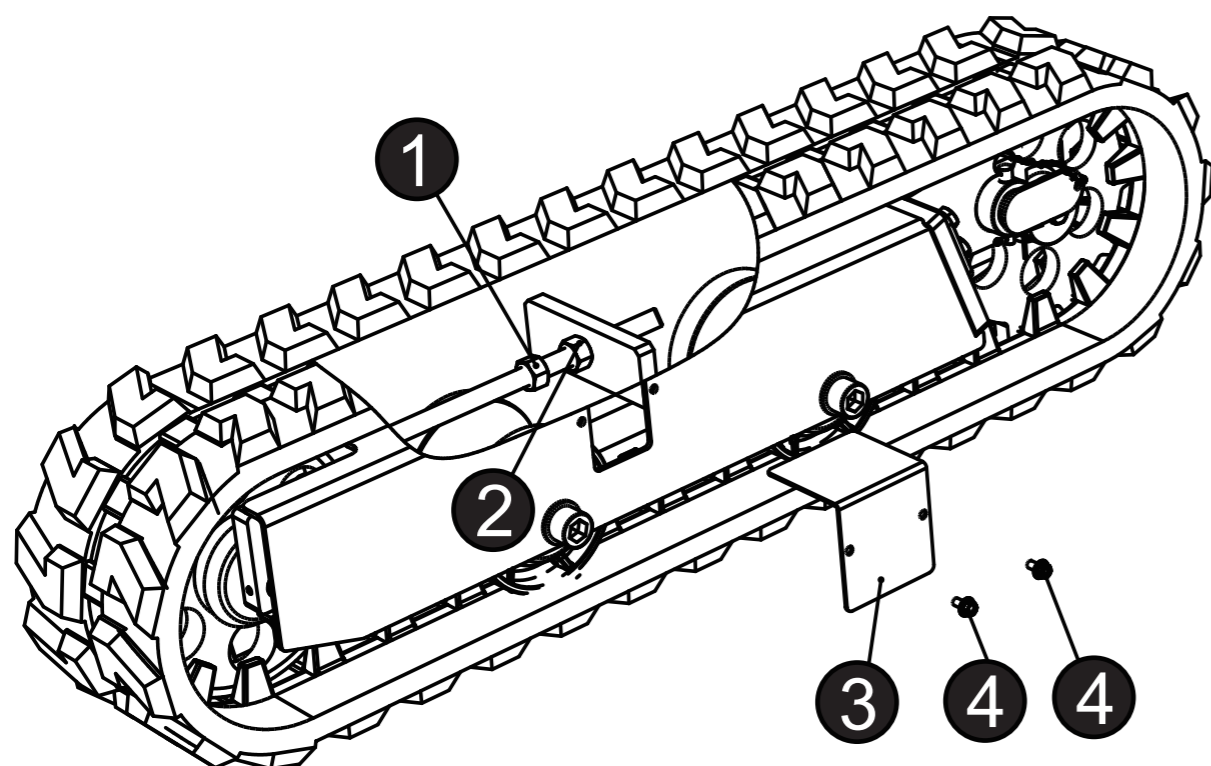

To correct tension of the tracks is important in order to guarantee their longevity and for your own safety.

- ☞ Take off the cover #3 by unscrewing the two screws #4.
- ☞ Using two wrenches, loosen the counter nut #2, tighten the nut #1.
- ☞ Put the cover back on.
- ☞ Repeat the same procedure on the other track.

## PART V: TROUBLESHOOTING TABLE

The information given in this chapter is provided for maintenance staff, for fast and reliable detection of malfunctions and their appropriate repair.

Repairs must be carried out by authorised staff.

SYMPTOM	Causes	Remedy
Hydraulic oil is leaking	Excessive oil level	Correct the oil level
	Overheated oil	Turn off the machine and let it cool down
	Breakdown in the hydraulic circuits	Have the machine looked at by a mechanic with specific competence
The machine does not move	The parking brake is activated	Deactivate the parking brake
	Not enough oil in the hydraulic circuit	Restore oil to the correct level
	The track are broken	Replace the tracks
	Breakdown in the hydraulic components	Have the motor looked at by a mechanic with this specific competence
Excessive noise from the body or from the arms of the bucket	Broken rollers	Greasing
	Needs greasing	Have the machine repaired by a mechanic
Excessive noise from the tracks during movement	Incorrect track tension	Register the tension
	Broken or worn tracks	Replace the tracks
	Broken rollers or ball bearings	Have the motor looked at by a mechanic with this specific competence
The motor does not work correctly or makes an excessive amount of noise	Various causes	Have the motor looked at by a mechanic with this specific competence
The motor does not develop power	The air filter is blocked	Replace the air filter
	Various causes	Have the motor looked at by a mechanic with this specific competence
The motor does not start	Not enough fuel	Refuel the machine
	The start-up procedure was not carried out correctly	Follow the correct start-up procedure

