

HYDRAULIC LOG SPLITTER

OPERATIONS MANUAL

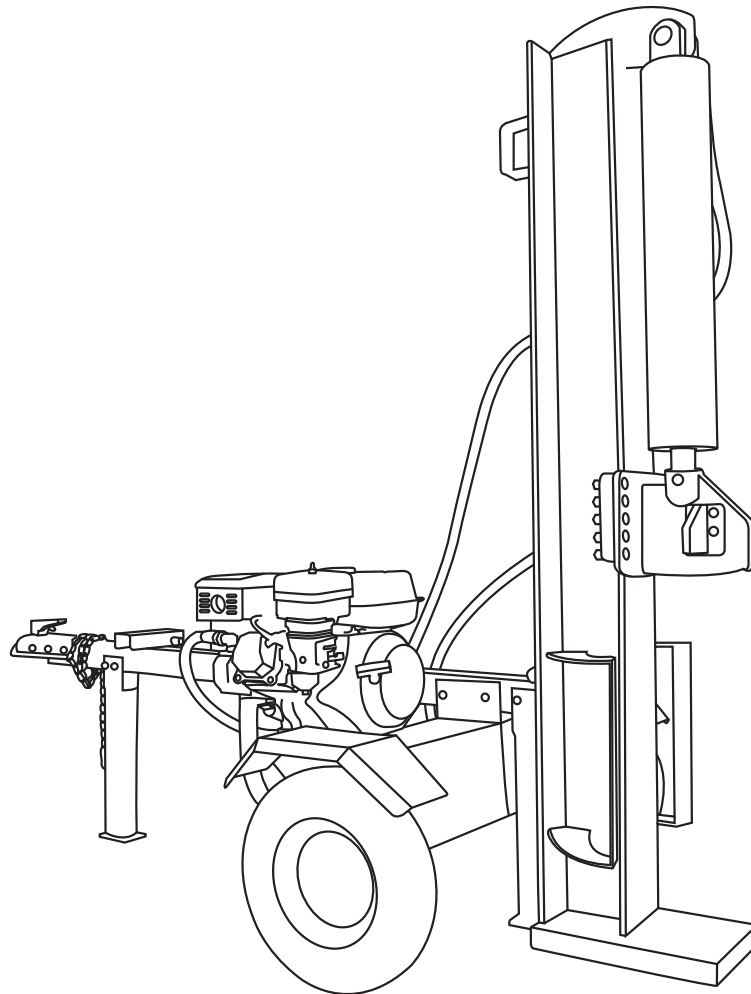

Fill engine and hydraulic system with oil before use or serious damage will occur.

TABLE OF CONTENTS

PREFACE	Pg 3
SAFETY INFORMATION	Pg 4
ASSEMBLING THE LOG SPLITTER	Pg 8
PREPARATION	Pg 13
SAFETY FUNCTIONS	Pg 14
LOG SPLITTER OPERATIONS	Pg 15
ADJUSTING YOUR LOG SPLITTER	Pg 19
MAINTENANCE	Pg 20
STORING YOUR LOG SPLITTER	Pg 22
TROUBLESHOOTING	Pg 23
PARTS DIAGRAM	Pg 26
PARTS LIST.....	Pg 27

PREFACE

This manual is used for both petrol (gasoline) and diesel models.

Check which model you have purchased.

Only use commercial pump diesel in diesel models.

Only use commercial non ethanol pump petrol/ fuel in petrol models.

Thanks for buying the 40 Tonne Log Splitter, another high-quality machine from our company.

To get the most out of your purchase, please read the manual before using the log splitter.

We ask you to please read this manual carefully beforehand in order to familiarise yourself with this product and after reading, please store this instructional manual for future reference. Keep this manual in a safe place for future and regular reference and for ordering replacement parts. Failure to follow the proper protocols listed in the manual may cause personal injury to the operator or damage to equipment.

Restrict the use of this power machine to persons who read, understand and follow the warnings and instructions in this manual and on the machine. Some of the safety labels are reproduced here. Always follow directions on safety labels found on your equipment.

Please pay special attention when you see this icon. 

SAFETY INFORMATION

GENERAL

- Be familiar with all controls and proper operation. Know how to stop the machine quickly.
- Never allow children to operate this machine. All users must read and understand instructions and safety rules in this manual.
- Many accidents occur when more than one person operates the machine. If a helper is assisting in loading logs, never activate the control until the helper is minimum of 10 feet from the machine.
- Keep bystanders, helpers, pets, and children at least 20 feet from the machine while it is in operation.
- Never allow anyone to ride on this machine
- Never transport cargo on this machine.
- Hydraulic log splitters develop high fluid pressures during operation. Fluid escaping through a pin hole opening can penetrate your skin and cause blood poisoning, gangrene, or death. Pay attention to the following instructions at all times:
 - a. Do not check for leaks with your hand.
 - b. Do not operate machine with frayed, kinked, cracked, or damaged hoses, fitting, or tubing.
 - c. Stop the engine and relieve hydraulic system pressure before changing or adjusting fittings, hoses, tubing, or other system components.
 - d. Do not adjust the pressure settings of the pump or valve.
- Leaks can be detected by passing cardboard or wood, (while wearing protective gloves and safety glasses) over the suspected area. Look for discoloration of cardboard or wood.
- If injured by escaping fluid, see a doctor immediately. Serious infection or reaction can develop if proper medical treatment is not administered immediately.
- Keep the operator zone and adjacent area clear for safe, secure footing.
- If your machine is equipped with an internal combustion engine and it is intended for use near any unimproved forest, brush, or grass covered land, the engine exhaust should be equipped with a spark arrester. Make sure you comply with applicable local, state, and federal codes. Take appropriate firefighting equipment with you.
- This machine should be used for splitting wood only, do not use it for any other purpose.

PREPARATION

- Always wear safety shoes or heavy boots.
- Always wear safety glasses or safety goggles during operating this machine.
- Never wear jewelry or loose clothing that might become entangled in moving or rotating parts of the machine.
- Make sure machine is on level surface before operating.
- Always block/chock the machine to prevent unintended movement and lock in either horizontal or vertical position.
- Always operate this machine from the operator zone(s) specified in the manual.
- Logs should be cut with square ends prior to splitting.
- Use log splitter in daylight or under good artificial light
- To avoid personal injury or property damage, use extreme care in handling fuel. Fuel is extremely flammable and the vapors are explosive. Serious personal injury can occur when fuel is spilled on yourself or your clothes which can ignite.
- Wash your skin and change immediately if fuel is spilled on you.
 - a. Use only an approved fuel container.
 - b. Extinguish all cigarettes, cigars, pipes, and other sources of ignition.
 - c. Never fuel machine indoors.
 - d. Never remove gas cap or add fuel while the engine is hot or running.
 - e. Allow engine to cool at least two minutes before refueling.
 - f. Never overfill the fuel tank. Fill tank to no more than 1/2 inch below bottom of filler neck to provide space for fuel expansion.
 - g. Replace fuel cap and tighten securely.
 - h. If fuel is spilled, wipe it off the engine and equipment. move machine to another area. Wait 5 minutes before starting the engine.
 - i. Never store the machine or fuel container inside where there is an open flame, spark or pilot light as on a water heater, space heater, furnace, clothes dryer or other gas appliances.
 - j. Allow machine to cool before storing.

OPERATION

- Never leave this machine unattended with the engine running.
- Do not operate machine while under the influence of alcohol, drugs, or medication.
- Never allow anyone to operate this machine without proper instruction.
- Always operate this machine with all safety equipment in place and working. Make sure all controls are properly adjusted for safe operation.
- Do not change the engine governor settings or overspeed the engine. The governor controls the maximum safe operating speed of the engine.
- When loading a log, always place your hands on the sides of the log, not on the ends, and never use your foot to help stabilize a log. Not following these instructions may result in crushed or amputated fingers, toes, hand, or foot.
- Use only your hand to operate the controls.
- Never attempt to split more than one log at a time unless the ram has fully extended and a second log is needed to complete the separation of the first log.
- For logs which are not cut square, the least square end and the longest portion of the log should be placed toward the beam and wedge, and the square end placed toward the end plate.
- When splitting in the vertical position, stabilize the log before moving the control. Split as follows:
 - a. Place log on the end plate and turn until it leans against the beam and is stable.
 - b. When splitting extra large or uneven logs, the log must be stabilized with wooden shims or split wood between the log and end plate or ground.
- Always keep fingers away from any cracks that open in the log while splitting. They can quickly close and pinch or amputate your fingers.
- Keep your work area clean. Immediately remove split wood around the machine so you do not stumble over it.
- Never move this machine while the engine is running.
- This machine should not be towed on any street, highway or public road.
- Do not tow machine faster than 45kph on smooth ground.
- See Transporting the Log Splitter section in this manual for proper towing instructions once all federal, local, or state requirements are met.

MAINTENANCE AND STORAGE

- In the case of a petrol engine, stop the engine, disconnect the spark plug and ground it against the engine before cleaning, or inspecting the machine.
- In the case of a diesel engine, stop the engine and disconnect the high pressure diesel line before cleaning or inspecting the machine.
- Stop the engine and relieve hydraulic system pressure before repairing or adjusting fittings, hoses, tubing, or other system components.
- To prevent fires, clean debris and chaff from the engine and muffler areas. If the engine is equipped with a spark arrester muffler, clean and inspect it regularly according to manufacturers instructions. Replace if damaged.
- Periodically check that all nuts and bolts, hose clamps, and hydraulic fittings are tight to be sure equipment is in safe working condition.
- Check all safety guards and shields to be sure they are in the proper position. Never operate with safety guards, shields, or other protective features removed.
- The pressure relief valve is preset at the factory. Do not adjust the valve.
- Never attempt to move this machine over hilly or uneven terrain without a tow vehicle or adequate help.
- For your safety, replace all damaged or worn parts immediately with original equipment manufacturer's (O.E.M.) parts only. "Use of parts which do not meet the original equipment specifications may lead to improper performance and compromise safety!"
- Do not alter this machine in any manner, alterations such as attaching a rope or extension to the control lever, or adding to the width or height of the wedge may result in personal injury.

UNPACKING FROM CRATE

ASSEMBLING THE LOG SPLITTER

2 people are required to assemble the splitter.

1. Pry top, sides, and ends off the pallet. Set panels aside to avoid tire puncture or personal injury.
2. Remove any loose parts if included with unit (i.e. operator's manual, etc.)
3. Cut and remove straps which secure parts to bottom of pallet. Unbolt and remaining parts which may be bolted to the bottom of the pallet.

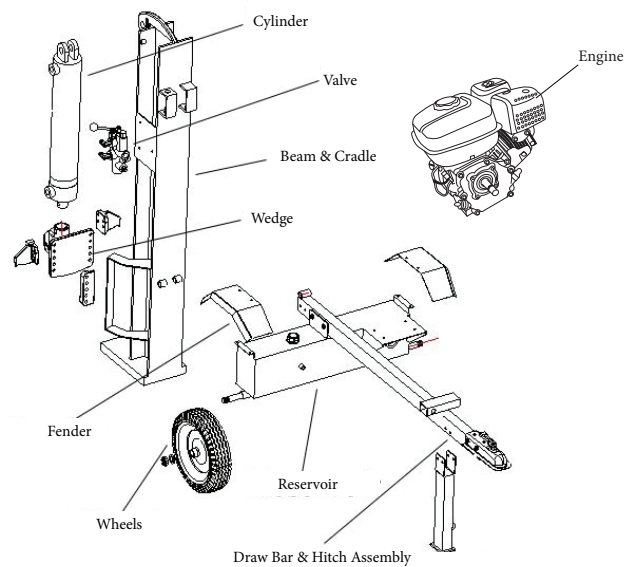

PARTS

	Loose Parts
1.	Reservoir Tank and Engine Pump Assembly
2.	Engine Pump
3.	Wedge, Beam and Cylinder Assembly
4.	Tongue Assembly
5.	Wheels
6.	Hitch Assembly
7.	Beam Support/Latch Bracket
8.	Log Cradle Brackets and Hardware
9.	Fenders
10.	Stand Assembly

HITCH ASSEMBLY

In some countries, the hitch assembly differs and may already be attached to the draw bar before shipping. If not, follow instructions below:

1. Remove the hardware from the hitch assembly and place the hitch on the end of the draw bar.
2. Insert hex bolt through flat washer, end of safety chain, spacer, and then rear hitch hole. Pivot the end of the safety chain so it faces the ball end of hitch.
3. Insert the other spacer, safety chain, and flat washer on the other end of the hex bolt and secure with the hex lock nut.
4. Insert hex bolt through the front hole of hitch and secure with flat washer and hex lock nut.
5. Tighten both hex nuts to 23 ft-lbs.

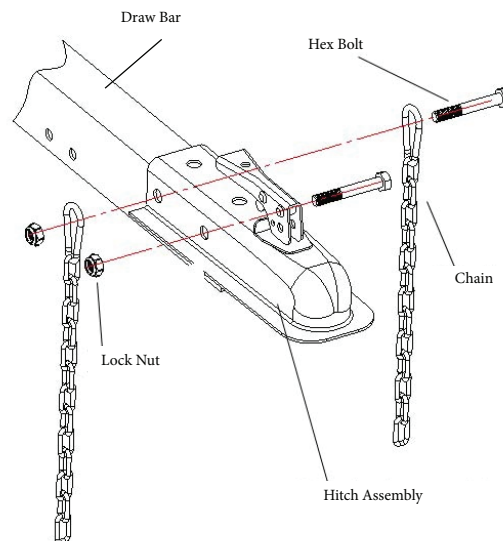



It is recommended that you polish the axles with emery cloth before you install the wheels

ATTACHING WHEELS

1. Block up / raise the reservoir tank assembly about eight to twelve inches.
2. Place a wheel on each axle with the valve stem facing outward.
3. Place a flat washer on each axle and secure with hex slotted nut.
4. Tighten slotted nut until snug and then back off approximately 1/3 turn or until one of the slots on the slotted nut lines up with the hole in the axle.
5. Insert cotter pins through slots in nuts and holes in axle and secure by bending the ends of the cotter pins in opposite directions.
6. The wheels should spin freely and there should be no side to side play.
7. Place hub caps in position on wheels and tap on to the axle with a soft hammer or mallet.



Maximum tire pressure under any circumstance is 30 psi. Equal tire pressure should be maintained at all times.

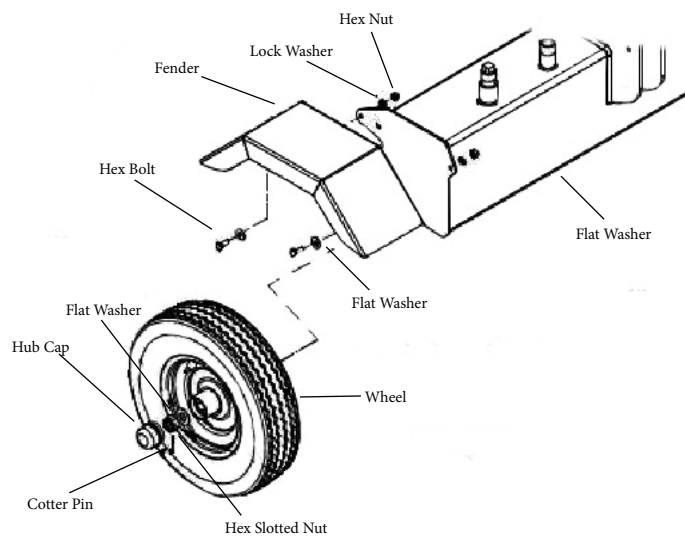

ATTACHING FENDERS

1. Remove the hex nuts, lock washers, flat washers, and hex bolts from the side of the tank.
2. Determine the proper assembly holes in the fenders over the tires against the tank.
3. Insert hex bolts through flat washers, holes in fenders, and tank. Secure fender with lock washers and hex nuts. Tighten securely.

ATTACHING THE BEAM

1. For shipping purposes, the pressure hose is often attached to the pump on the engine and to the control valve on the cylinder.
2. Disconnect the pressure hose from the adapter on the pump.
3. Stand the wedge, beam, and cylinder assembly upright with cylinder toward the top. An assistant is needed for this process.
4. Remove cotter pin and clevis pin from welded brackets on beam assembly and move the reservoir tank assembly in position against the beam.
5. Insert clevis pin just removed through brackets on beam and reservoir tank assembly. Secure with cotter pin by bending the ends of the pin in opposite directions.

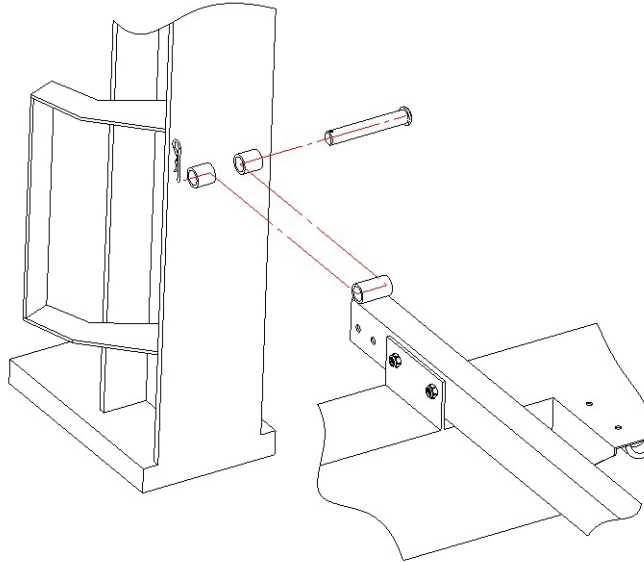

ATTACHING ENGINE-PUMP

1. Place the engine and pump assembly in position on the engine mounting bracket with the pump facing out.
2. Align holes in base of engine with appropriate holes in engine mounting bracket.
3. Secure the engine and pump assembly with four hex bolts, lock washers, and hex nuts packed with the manual.
4. Secure with lock washers and hex nuts. Tighten to 14 ft-lbs

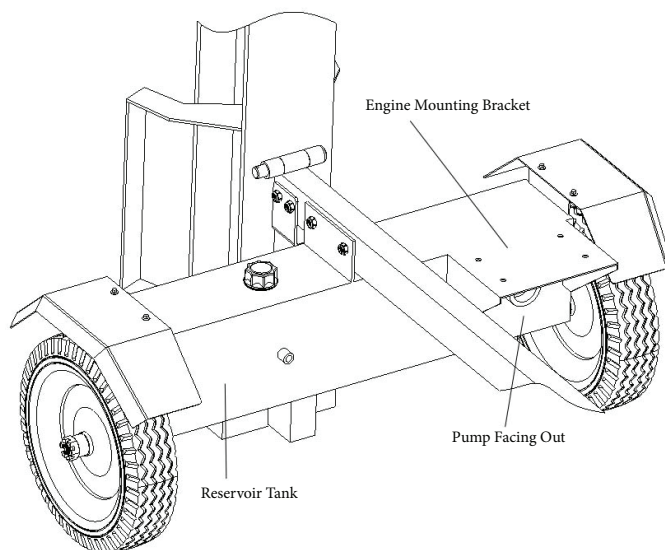

ATTACHING THE HOSES

Suction Hose

1. The suction is attached to the reservoir tank, beneath the engine mounting bracket. Loosen the hose clamp on the free end of the hose.
2. Remove any protective insert from the end of the hose.
3. Remove the protective cap from the fitting on the bottom of the pump (some oil may flow from pump).
4. Attach the end of the suction hose to the fitting on the bottom of the pump.
5. Place the hose clamp at the base of the fitting and tighten securely.

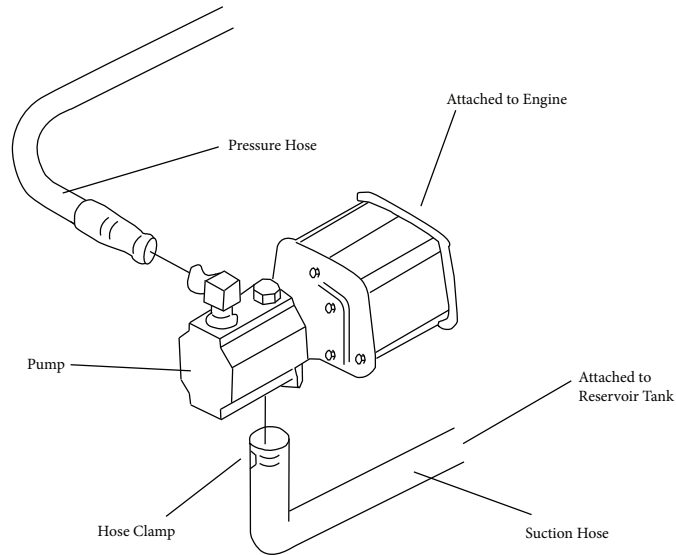

Pressure Hose

1. The pressure hose is attached to the right side of control valve.
2. Secure the pressure hose to the the top of the pump.
3. Secure long hose runs to the back of the ram and pushes the ram open, therefore the handle needs to be held on to open the ram/split the wood.
4. The shorter hose runs from the front of the ram - the shaft end, and is the return and /or by-pass hose. Here the valve handle can be pushed and locked in till the ram is fully retracted and the valve will automatically click back into neutral.

Return Hose

1. Remove any protective insert from the end of the hose.
2. The return hose is attached to the left side of the control valve.
3. Cut the securing strap.
4. Secure the return hose to the reservoir tank.

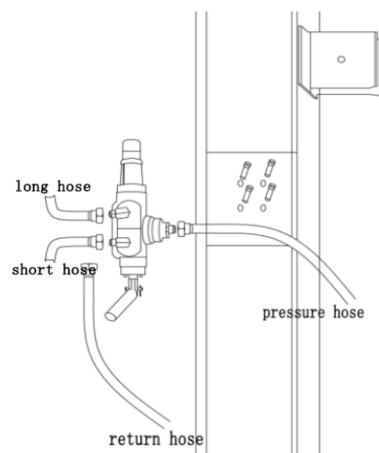

PREPARATION

1. Lubricate the beam area where the splitting wedge will slide with engine oil. Do not use grease.
2. Remove vented reservoir dipstick (hydraulic oil cap), which is located in front of the engine on top of the reservoir tank.
3. Fill the reservoir tank with ISO 46 or similar Hydraulic oil or as recommended by your local hydraulic oil supplier.
4. Check fluid level using the dipstick. The reservoir tank has a capacity of approximately 25 - 30 litres depending on model. Do not overfill.
5. Replace vented dipstick securely. Tighten the dipstick until the top of the threads are flush with the top of the pipe.
6. With the engine switch "off", disconnect the spark plug wire and prime the pump, by pulling the recoil starter to turn the engine over approximately 10 times. Always be prepared for the engine to unexpectedly start.
7. Connect the spark plug wire if not already connected (petrol engines only).
8. Start engine according to instructions.
9. Use control handle to engage the wedge to the farthest extended position and then retract it.
10. Refill tank to within the range specified on the dipstick.
11. Extend and retract the wedge 12 complete cycles to remove trapped air (system is "self-bleeding").
12. Much of the original fluid has been drawn into the cylinder and hoses. Make certain to refill the reservoir to prevent extreme damage to the hydraulic pump. Failure to refill the tank will void your warranty.



Some fluid may overflow from the vented reservoir dipstick as the system builds heat and the fluid expands and seeks a balanced level.



Do not operate the log splitter without the proper amount of oil in the reservoir.

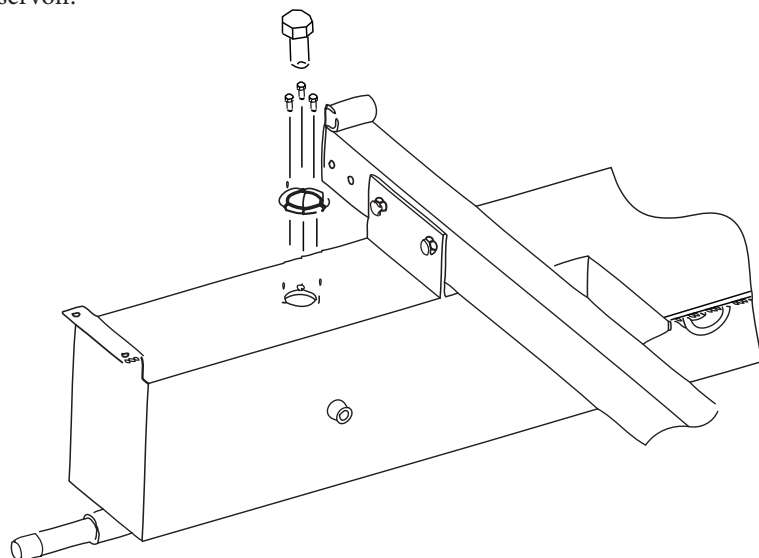

SAFETY FUNCTIONS

CONTROL HANDLE

The control handle has three positions.

Hold the control lever in the direction you wish the splitting wedge to travel. Return to the central position to stop wedge movement.

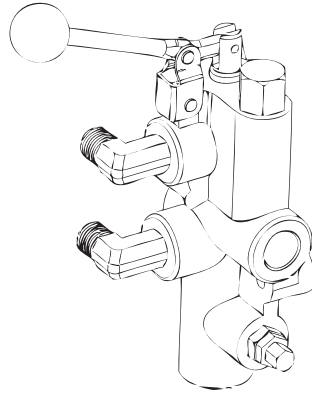

STOPPING THE ENGINE

1. Turn engine switch to **off** position.
2. Turn off the fuel valve.
3. On petrol engines, disconnect the spark plug wire and ground against the engine to prevent unintended starting.

HORIZONTAL & VERTICAL BEAM LOCKS

These two locks, as their name suggests, are used to secure the beam in the horizontal or the vertical position. The vertical beam lock is located next to the oil filter. The horizontal beam lock is located on the beam support latch bracket.

LOG SPLITTER OPERATION



Read, understand, and follow all instructions and warnings on the machine and in this manual before operating.



Wear leather work gloves, safety shoes, ear protection, and safety glasses when operating the log splitter. Ensure safe footing.

GAS & OIL FILL-UP

Fill your engine with 10w-30/ 10w-40/ 15w-30/ 15w-40 non-synthetic engine oil before use or serious damage will occur.



Use extreme care when handling fuel. Fuel is extremely flammable and the vapors are explosive. Never fuel machine indoors or while the engine is hot or running.



Fuel can be added to the engine when the log splitter is in either the horizontal or vertical position. However, there are less obstructions when the unit is in the vertical position.

BEFORE EACH USE

1. Remove the dipstick and check hydraulic fluid level. Refill if necessary.
2. Check engine oil level. Refill if necessary.
3. Fill up fuel if necessary.
4. Lubricate with engine oil the beam area where splitting wedge will slide. Do not use grease to lubricate. Make sure to lubricate both the front and the back of the beam face.
5. Attach spark plug wire to the spark plug.

STARTING THE ENGINE

1. When a petrol engine is used, attach the spark plug wire to the spark plug. Make certain the metal cap on the end of the spark plug wire is fastened securely over metal tip of the spark plug.
2. Turn the fuel valve to the **on** position.
3. Move choke lever to **choke** position (petrol engine only).
4. Slide the throttle control lever about one-third way towards the **fast** position.
5. Turn engine switch to **on** position.
6. Grasp starter handle and pull rope out slowly until engine reaches start of compression cycle (rope will pull slightly harder at this point).
7. Pull rope with a rapid, full arm stroke. Keep firm grip on starter handle. Let rope rewind slowly. Repeat until engine cranks.
8. After engine starts, move choke lever to **off** position (petrol engine only). Place throttle lever to the speed desired. For best performance, the engine is designed to be operated at the **fast** throttle position.
9. If weather is cold, run wedge up or down beam 6 to 8 times to circulate the hydraulic fluid.



When starting a warm engine, the muffler and surrounding areas are hot and can cause a burn. Do not touch.

USING THE LOG SPLITTER

1. Place the log splitter on level, dry ground.
2. Place the beam in either the horizontal or vertical position and lock in place with the appropriate locking rod.
3. Block/chock the front and back of both wheels.
4. Place the log against the end plate and only split wood in the direction of the grain.



To stabilise the log, place your hand only on sides of log. **Never place your hand** on the end between the log and the splitting wedge.



Only one adult should stabilise the log and operate the control handle, so the operator has full control over the log and the splitting wedge.

Control Handle

Hold the control lever in the direction you wish the splitting wedge to travel. Return to the central position to stop wedge movement.

Vertical Position

1. Pull the horizontal beam lock out to release the beam and pivot the beam to the vertical position.
2. To lock the beam in the vertical position, pull out on the vertical beam lock to secure the beam.
3. Stand in front of the unit to operate the control handle and to stabilise the log. See A.

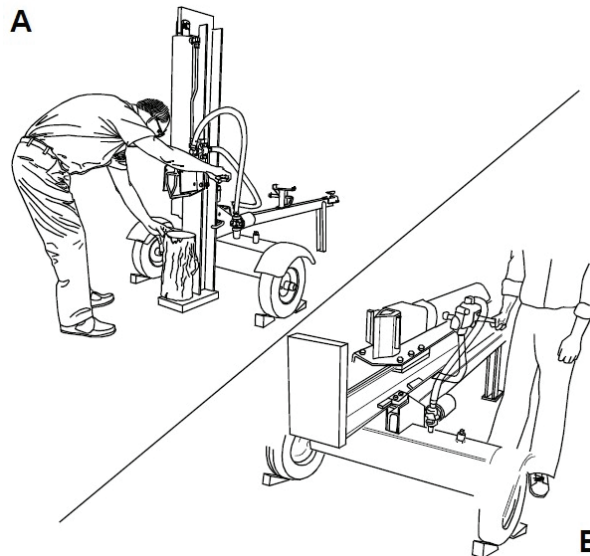

Horizontal Position

1. Pull the vertical beam lock out and rotate it down. Pivot beam to the horizontal position. The beam will lock automatically in the horizontal position.
2. Stand behind the reservoir tank to operate control handle and to stabilise the log. See B.

OPERATING TIPS

Always:

- Use clean fluid and check fluid level regularly.
- Use a filter (clean or replace regularly)
- Make sure pump is mounted and aligned properly.
- Keep hoses clear and unblocked.
- Bleed air out of hoses before operating.
- Flush and clean hydraulic system before restarting after servicing.
- Allow time for warm-up before splitting wood.
- Split wood along the grain (lengthwise) only.

Never:

- Use when fluid is below -7°C or above 50°C .
- Operate through relief valve for long.
- Attempt to adjust unloading or relief valve settings without pressure gauges.
- Operate with air in hydraulic system.
- Attempt to cut wood across the grain.

RAISING AND LOWERING BEAMS

- Use the control handle to run wedge up and down beam 6 to 8 times to circulate the hydraulic fluid, which will warm and thin the fluid.
- Place log splitter on a firm, level surface.

To raise the beam for vertical operation:

1. Pull out the horizontal beam lock on the draw bar.
2. Pivot the beam lock down to release the beam.
3. Move the beam to the vertical position. Secure it with the beam lock on the reservoir tank assembly.



Always use the log splitter in the vertical position when **splitting heavy logs**.

To lower the beam:

1. Pull out the vertical beam lock on the reservoir tank.
2. Pivot the beam lock down to release the beam.
3. Carefully pull back on beam and lower it to the horizontal position.
4. Pull out the beam lock on the tongue, pivot it upwards and release it to hold the beam. Make certain it is latched securely.

TRANSPORTING THE SPLITTER

Always turn the fuel valve to **off** position before transporting the log splitter.

1. Lower the beam to its horizontal position. Make certain the beam is locked securely with the horizontal beam lock.
2. Attach hitch coupler to a class I or higher hitch with a suitable ball on the towing vehicle, making sure to latch securely.
 - a. If the coupler hitch does not fit on the ball, turn the adjustment nut one turn counterclockwise.
 - b. If the coupler hitch is too loose on the ball, turn the adjustment nut one turn clockwise.
3. Connect the safety chains to the towing vehicle.



Do not tow faster than 45km/hr on a smooth surface. The splitter cannot be towed on a public road in Australia or New Zealand.



Use caution when reversing. It is recommended to use a spotter outside the vehicle.

WEDGE ASSEMBLY ADJUSTMENT

ADJUSTING YOUR LOG SPLITTER

Do not at any time make any adjustments without first stopping the engine, disconnecting spark plug wire, and grounding it against the engine.

In the case of a diesel engine, stop the engine and disconnect the high pressure diesel line.

As normal wear occurs and there is excessive “play” between the wedge and beam, adjust the bolts on the side of the wedge assembly to eliminate excess space between the wedge and the beam.

1. Loosen the jam nuts on the two adjustment bolts on the side of the wedge.
2. Turn the adjustment bolts in until snug and then back them off slowly until the wedge assembly will slide on the beam.
3. Tighten the jam nuts securely against the side of the wedge to hold the adjustment bolts in this position.

MAINTENANCE



Before cleaning, lubricating, repairing or inspecting, disengage the control lever and stop engine. For petrol engines, disconnect the spark plug wire and ground it against the engine to prevent unintended starting. In the case of a diesel engine, stop the engine and disconnect the high pressure diesel line.

CONDITIONS THAT WILL VOID THE WARRANTY

- Failure to maintain proper fluid level in the reservoir
- Changing the relief valve setting or pressure adjustment of control valve without proper knowledge and instruction from the factory.
Higher pressure could cause the hoses to burst, cylinder to rupture, and intense fluid to be released, which could result in serious personal injury.
- Disassembling the pump
- Use of incorrect hydraulic fluid
- Allowing the flexible pump coupler to deteriorate without proper and regular inspection
- Lack of lubrication or improper lubrication of the beam or unit
- Improper adjustment of splitting wedge
- Excessive heating of the hydraulic system
- Attempting to start unit in temperatures under -7°C without pre-heating fluid in the reservoir
- Unattended leaks in the hydraulic system

HYDRAULIC FLUID

- Check the hydraulic fluid level in the log splitter reservoir tank before each use.
- Maintain fluid level within the range specified on the dipstick at all times.
- Change the hydraulic fluid in the reservoir every 100 hours of operation.
- Disconnect the suction hose from the bottom of the reservoir tank and drain the fluid into a suitable container.

Please dispose of used hydraulic fluid and engine oil at approved recycling centres only.



- Since contaminants in fluid may damage the hydraulic components, you will have to drain the fluid and flush the reservoir tank and hoses with kerosene whenever any repair work is performed on the tank, hydraulic pump or valve. For this job, contact your nearest service dealer.

BEAM AND SPLITTING WEDGE

Lubricate both sides of the beam (where it comes into contact with the splitting wedge), before each use, with engine oil. The wedge plate on the log splitter is designed so the gibs on the side of the wedge plate can be removed and rotated and/or turned over for even wear.

Make certain to readjust the adjustment bolts so wedge moves freely, but no excess space exists between the wedge plate and the beam.

HOSE CLAMPS

Check, before each use, if hose clamps on the suction hose (attached to the side of the pump) are tight. Check the hose clamps on the return hose at least once a season.

TIRES

See sidewall of tire for recommended pressure. Maximum tire pressure under any circumstances is 30 p.s.i. Maintain equal pressure on all tires.



Excessive pressure (over 30 p.s.i.) when seating beads may cause tire/rim assembly to burst with force sufficient enough to cause serious injury.

STORING YOUR LOG SPLITTER

Prepare your log splitter for storage at the end of the season or if the log splitter remains unused for 30 days or more.



Never store machine with fuel in the fuel tank inside of building where fumes may reach an open flame or spark, or where ignition sources are present such as hot water and space heaters, furnaces, clothes dryers, stoves, electric motors, etc.



We do not recommend the use of pressure washers or garden hose to clean your unit. These may cause damage to electric components, spindles, pulleys, bearings or the engine. The use of water will shorten life and reduce serviceability.

- Clean the log splitter thoroughly.
- Wipe unit with an oiled rag to prevent rust, especially on the wedge and the beam.
- Drain fuel tank. Always drain fuel into approved container outdoors, away from open flame. Be sure that engine is cool before draining the fuel. Do not smoke while handling fuel.
- Start the engine and let it run until the fuel lines and carburetor are empty (petrol engines only).
- Remove spark plug, pour approximately 1/2 ounce (approximately one tablespoon) of engine oil into cylinder and crank slowly to distribute oil (petrol engines only).
- Replace spark plug (petrol engines only).
- Do not store fuel from one season to another.
- Replace your fuel can if it starts to rust. Rust and/or dirt in the fuel will cause problems.
- Store unit in a clean, dry area. Do not store next to corrosive materials, such as fertiliser.



If storing in an unventilated or metal storage shed, be certain to rustproof the equipment by coating with a light oil or silicone.

TROUBLE SHOOTING

Problem	Possible Cause	Solution
Engine does not start	Spark plug disconnected (petrol engines only)	Connect wire to spark plug
	Fuel tank is empty or fuel is stale	Fill the tank with clean, fresh fuel
	Fuel shut-off valve closed	Turn the valve to on position
	Throttle control lever is not in the correct starting position	Move the throttle lever to the FAST position
	Choke is not in the choke position (petrol engines only)	Move choke to choke position
	Engine is not primed properly	Prime engine
	Blocked fuel line	Clean the fuel line
	Faulty spark plug (petrol engines only)	Clean, adjust gap and replace
Engine runs erratically	Spark plug wire is loose (petrol engines only)	Connect and tighten spark plug wire
	Unit is running on choke (petrol engines only)	Move choke lever to the off position
	Blocked fuel line or stale fuel	Clean fuel line and fill the tank with clean, fresh fuel
	Water or dirt in the fuel system	Drain fuel tank. Refill with fresh fuel.
	Dirty air cleaner	Clean or replace air cleaner
	Carburetor out of adjustment (petrol engines only)	See authorised service dealer
Engine overheats	Engine oil level low	Fill crankcase with proper oil
	Dirty air cleaner	Clean or replace air cleaner
	Carburetor not adjusted properly (petrol engines only)	See authorised service dealer

Hydraulic Troubleshooting		
Cylinder rod will not move	Broken drive shaft	See authorised service dealer
	Shipping plugs left in hydraulic hoses	Disconnect hydraulic hoses, remove shipping plugs, reconnect hoses.
	Set screws in coupling not adjusted properly	Adjust coupling screws
	Loose shaft coupling	Correct engine/pump alignment as necessary
	Gear sections damaged	See authorised service dealer
	Damaged relief valve	See authorised service dealer
	Hydraulic lines blocked	Flush and clean hydraulic system
Extremely slow cylinder shaft speed while extending and retracting	Gear sections damaged	See authorised service dealer
	Excessive pump inlet vacuum	Make certain pump inlet hoses are clear and unblocked. Use short, large diameter inlet hoses
	Slow engine speed	See authorised service dealer
	Damaged relief valve	See authorised service dealer
	Incorrect oil level	Check oil level
	Contaminated oil	Drain oil, clean reservoir and refill
	Directional valve leaking internally	See authorised service dealer
	Internally damaged cylinder	See authorised service dealer
Leaking cylinder	Broken seals	See authorised service dealer
	Scored cylinder	See authorised service dealer
Engine runs but wood will not split or wood splits extremely slowly	Small gear section damaged	See authorised service dealer
	Pump check valve leaking	See authorised service dealer
	Excessive pump inlet vacuum	Make certain pump inlet hoses are clear and unblocked
	Incorrect oil level	Check oil level

	Contaminated oil	Drain oil, clean reservoir and refill
	Directional valve leaking internally	See authorised service dealer
	Overloaded cylinder	Do not attempt to split wood against the grain
	Internally damaged cylinder	See authorised service dealer
Engine stalls during splitting	Low horsepower/weak engine	See authorised service dealer
	Overloaded cylinder	Do not attempt to split wood against the grain
Engine will not turn or stalls under low load conditions	Engine/ pump misalignment	Correct alignment as necessary
	Frozen or seized pump	See authorised service dealer
	Low horsepower/ weak engine	See authorised service dealer
	Hydraulic lines blocked	Flush and clean hydraulic system
	Blocked directional valve	Flush and clean hydraulic system
Leaking pump shaft seal	Broken drive shaft	See authorised service dealer
	Engine/pump misalignment	Correct alignment as necessary
	Gear sections damaged	See authorised service dealer
	Poorly positioned shaft seal	See authorised service dealer
	Plugged oil breather	Make certain reservoir is properly vented

PARTS DIAGRAM

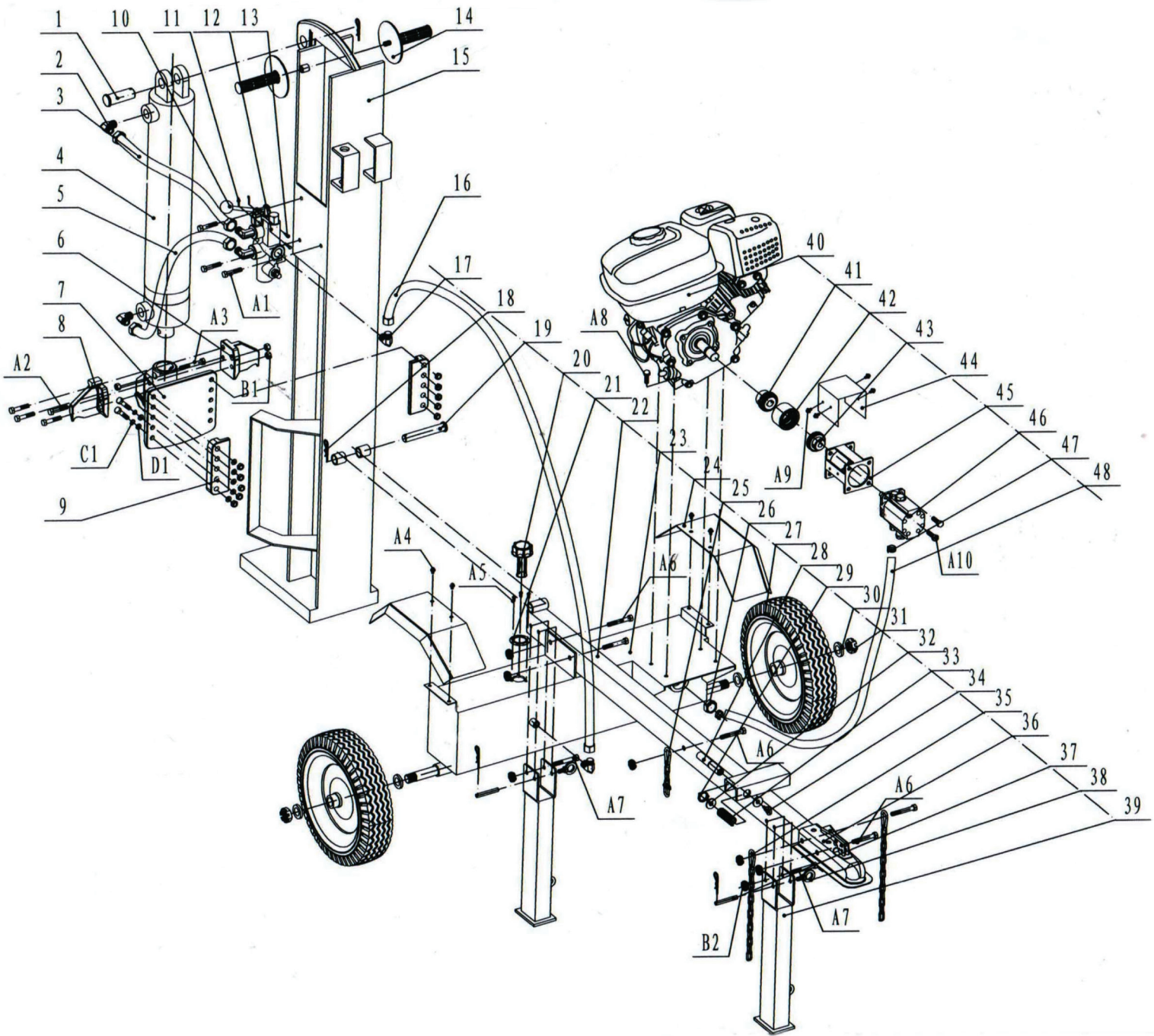

PARTS LIST

No.	Part	No.	Part
1	Clevis Pin	32	Flat Washer
2	90 Degree Solid Male Adapter	33	Compression Spring
3	Hydraulic Tube	34	Locking Rod
4	Hydraulic Cylinder	35	Chain
5	Hydraulic Tube	36	Hitch Coupler
6	Side Wedge	37	Hex Cap Screw
7	Wedge	38	Locking Rod
8	Side Wedge	39	Stand
9	Back Plate	40	Engine
10	Control Lever	41	Coupling
11	Cotter Pin	42	Coupling
12	Valve	43	Coupling
13	Cotter Pin	44	Shoulder Spacer
14	Hand Grip	45	Coupling Protector
15	Beam Assembly	46	Pump
16	Hydraulic Tube	47	Adapter
17	90 Degree Solid Male Adapter	48	Hydraulic Tube
18	Cotter Pin	A1	Hex Screw
19	Hinge Pin	A2	Hex Screw
20	Oil Tank Cap	A3	Hex Screw
21	Gasket	A4	Hex Cap Screw
22	Draw Bar	A5	Screw
23	Oil Tank	A6	Screw
24	Fender	A7	Hex Screw
25	Chain	A8	Hex Cap Screw
26	Oil Filter	A9	Screw
27	Wheel Assembly	A10	Screw
28	Pin Clamp	B1	Hex Nut
29	Lock Washer	B2	Lock Nut
30	Flat Washer	C1	Lock Washer
31	Slotted Nut	D1	Flat Washer