

USER'S MANUAL

Hydraulic Breaker



Contents

OPERATION MANUAL

01. Safety Precautions	1
02. Preparation for Installation and Operation	4
2.1 Checking before installation instructions	4
2.2 Installation and Removal	5
2.3 Hydraulic pipe lines for exclusive use	8
03. Precautions for safe operation	9
04. Maintenance	15
05. Inspection and Charging of N₂ Gas at Back head	20
06. Inspection and Charging of N₂ gas in Accumulator	22
07. Trouble Shooting	24
08. Hydraulic Oil	25
09. The Auto Lubrication Kit(Optional)	27
10. Underwater Operation of the Breaker(Optional)	28

PART LIST

Main Body

WHB 20,25,30,35,40	29
WHB 45,50	31

01. Safety Precautions

This manual contains safety, operation, and routine maintenance instructions. It doesn't contain service disassembly and service assembly instructions. If needed, complete service disassembly and service assembly instructions are contained in manual which can be ordered from your Soosan Hydraulic Breaker authorized and certified dealer.

Please read the following warning.



Serious injury or death could result from the improper repair or service of this breaker. Repairs or service to this breaker must only be done by an authorized and certified dealer.

Most of the accidents are caused by disregarding the basic rules of operation inspection or repair, or by neglecting the inspection before operation. Many accidents can often be avoided by recognizing potentially hazardous situations before an accident occurs. Before operating, inspecting or repairing this machine, be sure to read and fully understand the preventive methods and warnings described on the machine or in this manual. If not, never operate, inspect or repair this machine

Safety labels and messages are classified as follows so that the users can understand the warnings on the machine or in this manual.



Indicates an imminently hazardous situation which, if not avoided, will result in death or serious injury. This signal word is to be limited to the most extreme situations



Indicates a potentially hazardous situation which, if not avoided, could result in death or serious injury.



Indicates a potentially hazardous situation which, if not avoided, may result in minor or moderate injury, It may also be used to alert against unsafe practices.

NOTICE

Signs used to indicate a statement of company policy directly or indirectly related to the safety of personal or protection of property.

The safety messages including the preventive measures to avoid danger.

For safety, common items are described in "SAFETY PRECAUTIONS", and others are mentioned in the succeeding pages.

Soosan cannot anticipate every possible circumstance that might involve a potential hazard on operation, inspection or repair. Therefore the warnings in this manual are not all inclusive. If an operation, inspection or repair not described in this manual is used, you must take measures for safety by yourself.



Observe the cautions and take a preventive measure for safety

The best Hydraulic Breaker will provide safe and dependable service if operated in accordance with the instructions given in this manual. Read and understand this manual, any decals and tags attached to the breaker before operation. Failure to do so could result in personal injury or equipment damage

- Operate the breaker in accordance with all laws and regulations which affect you, your equipment, and the worksite.
- Do not operate the breaker until you have read this manual and thoroughly understood all safety, operation and maintenance instructions.
- Do not operate the breaker until you have read the carrier equipment manual and thoroughly understood backhoe or excavator or similar equipment used to operate the breaker. The word "carrier", as used in this manual, means a backhoe or excavator or similar equipment used to operate the breaker.
- Ensure that all maintenance procedures recommended in this manual are completed before using the equipment.
- The operator must not operate the breaker or carrier if any people are within the area where they may be injured by flying debris or movement of the equipment.
- Know the limits of your equipment.
- Before starting a work, Check the prohibitions, cautions and working processes in a working site with the field overseer, Observe all of them strictly.
- Wear such protective tools as a helmet, safety shoes, etc. to perform a work.
Make use of the protective glasses, earplugs, gloves and other protective tools if necessary.
- Establish a training program for all operators to ensure safe operation. Do not operate the breaker unless thoroughly trained or under the supervision of an instructor. Become familiar with the carrier controls before operating carrier and breaker. While learning operate the breaker and carrier, do so at a slow pace. If necessary, set the carrier to the slow position.
- Make sure all controls (levers and pedals) are in the neutral position before starting the carrier.
- Before leaving the carrier, always lower the boom and insure the carrier is stable. Never leave the machine with the engine running. Always engage the parking brake.
- Stop the engine before attempting to make any repairs, adjustments or servicing to either the carrier or the breaker.
- Do not operate the breaker at oil temperature above 175°F/80°C. Operation at higher temperature can damage the internal components of the breaker and carrier and will result in reduced breaker performance.
- Do not operate a damaged, leaking, improperly adjusted, or incompletely assembled breaker.



- Do not modify this breaker in any manner.
- Use only breaker parts manufactured by Soosan. Usage of breaker rod produced by another manufacturer may damage the breaker and will void the warranty.
- To avoid personal injury or equipment damage, all breaker repair, maintenance and service must only be performed by authorized and properly trained personnel.
- If you do not understand how to operate safely your breaker, contact an authorized Soosan Dealer for assistance.
- Keep this manual with the breaker.
- Do not operate this equipment if you are taking medication which may affect your mental judgement or physical performance.
- Do not operate this equipment if you are under the influence of drug or alcohol.
- Remove breaker from carrier during transportation.

02. Preparation for Installation and Operation.

2.1 Checking before installation instructions

 **CAUTION**

CHECK THE "SPECIFICATIONS" SECTION OF THIS MANUAL TO DETERMINE CORRECT EXCAVATOR SIZES AND HYDRAULIC PRESSURE, HYDRAULIC FLOW IF HYDRAULIC PRESSURE, HYDRAULIC FLOW ARE EXCEEDED, THE HYDRAULIC BREAKER WARRANTY IS VOID

 **CAUTION**

BE SURE THE FLUID IN THE HYDRAULIC SYSTEM IS CLEAN. CHECK THE HYDRAULIC FILTER, REPLACE THE FILTER IF DIRTY OR DETERIORATED. CHECK THE GAS PRESSURE ACCUMULATOR AND BACK HEAD. SEE INSPECTION AND CHARGING OF NITROGEN GAS AT BACK HEAD, ACCUMULATOR HOSE AND PIPING FLEXING.

 **CAUTION**

THE CONTAMINATED PART MUST BE CLEANED WITH NO DELAY. HYDRAULIC OIL OR LIGHT OIL IS HIGHLY RECOMMENDABLE.

 **CAUTION**

THE CIRCUIT RELIEF SETTING PRESSURE IS NOT FIXED. BUT, IT WILL BE ADJUSTED BY PUMP CAPACITY.

■ Recommended circuit relief setting pressure and back pressure

MODEL	WHB10	WHB20	WHB30	WHB35	WHB40	WHB43	WHB43B	WHB45	WHB50
Relief Setting Pressure [kg/cm ²]	150	150	160	160	170	180	190	190	200
Back Pressure [kg/cm ²]	16	16	16	16	16	16	16	16	16

2.2 Installation and Removal

■ Side Bracket Type

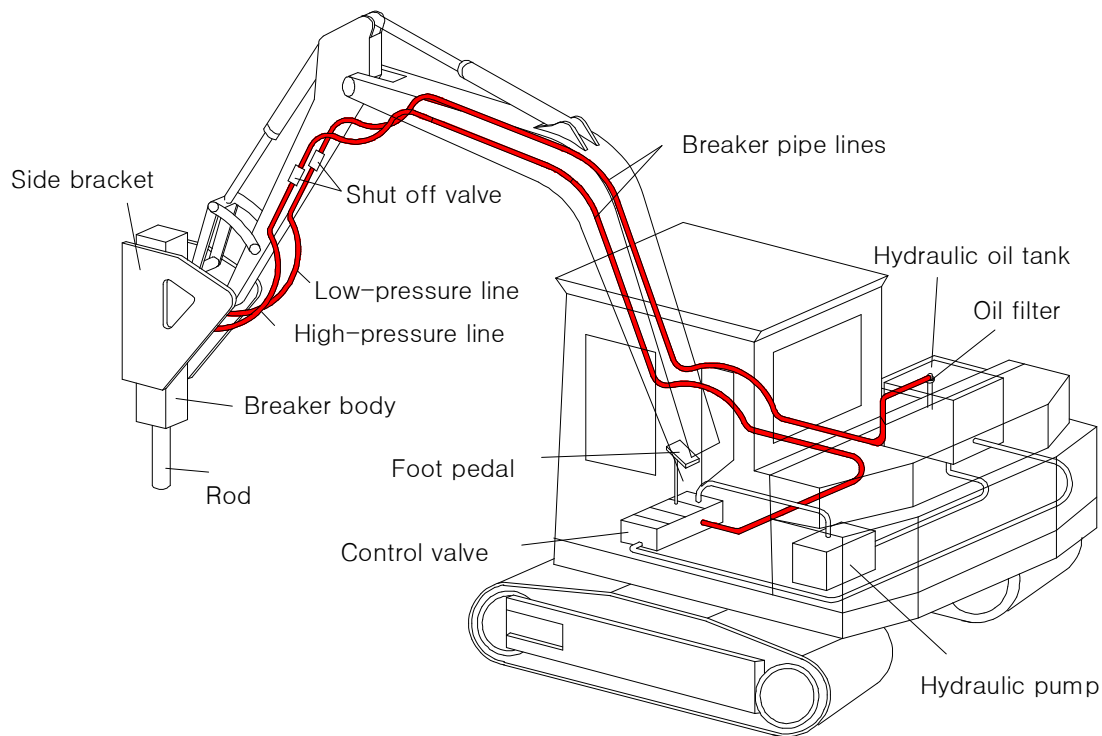

■ Top Bracket Type & Trench Type.

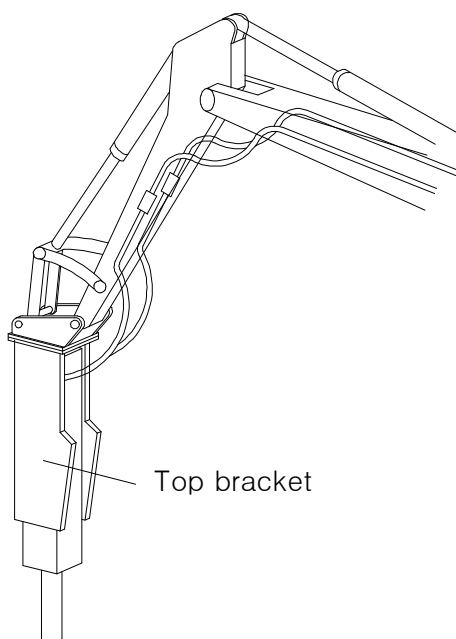

■ Removal of the Hydraulic Breaker

When the bucket and breaker operation alternately, the bucket and breaker can be easily exchanged by the hydraulic hoses and two mounting pins. However there is a risk of hydraulic contamination accordingly, do installation and removal as follows.

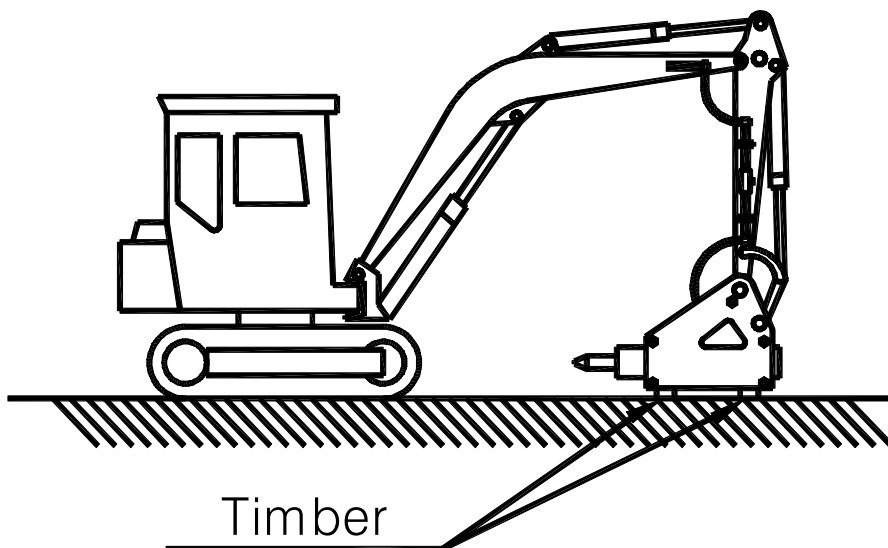

- (1) Move the carrier to stable ground free from mud, dust and dirt.
- (2) Place the hydraulic breaker on timber.
- (3) Stop the engine, turn off the main switch and deflate air from oil tank if it is
- (4) Turn 90° the shut off valve installed to the end of arm to prevent hydraulic from flowing out.

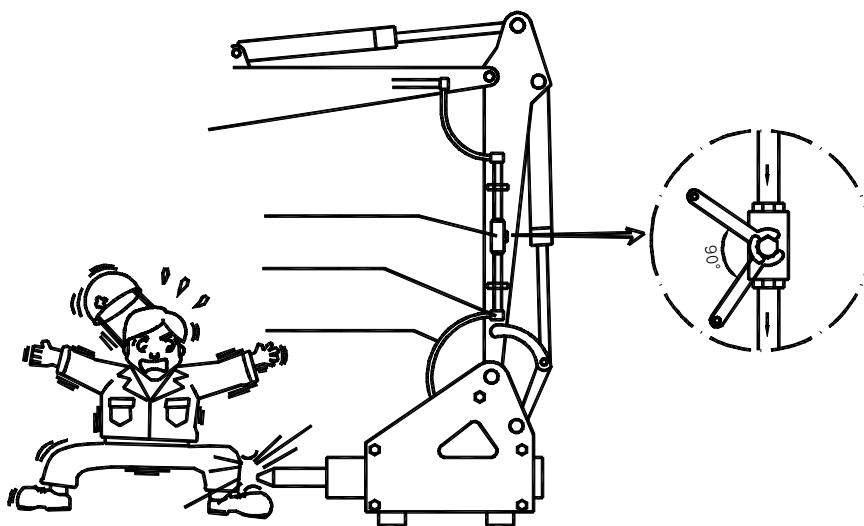

- (5) Loosen hose plug on the breaker arm. Collect small amount of oil flowing out at this time and put into a container.
- (6) Be careful to prevent mud or dust from entering oil hoses and pipe lines. Plug oil hoses with hose plug and pipe lines with union caps. Bind high-and low-pressure hoses with a wire to prevent them from getting mud.

■ Oil hose plug

The oil hose plug is used to plug the hose attached to the hydraulic breaker. It prevents mud or dust from entering the hose when the hydraulic breaker is removed from the carrier for bucket operation.

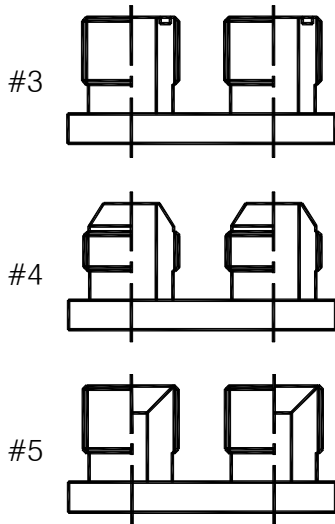

MODEL	TYPE	P/ N	TYPE	P/ N	TYPE	P/ N	O-RING (#3)
WHB20	-	-	# 5	C04100	# 4	C04332	-
WHB30	-	-	# 5	C04100	# 4	C04332	-
WHB35	-	-	# 5	C04100	# 4	C04332	-
WHB40	-	-	# 5	C04100	# 4	C04332	-
WHB43	-	-	# 5	C04100	# 4	C04332	-
WHB43B	# 3	C14100	# 5	C14410	# 4	C14372	2856003
WHB45	# 3	C14100	# 5	C14410	# 4	C14372	2856003
WHB50	# 3	C14100	# 5	C14410	# 4	C14372	2856003
WHB60	# 3	C34100	# 5	C14411	# 4	C34050	2856004
WHB70	# 3	C34100	# 5	C14411	# 4	C34050	2856004

■ Union cap

The union cap is used to cap the piping bracket attached to the carrier for prevention of the piping bracket from being smeared with mud during bucket operation.

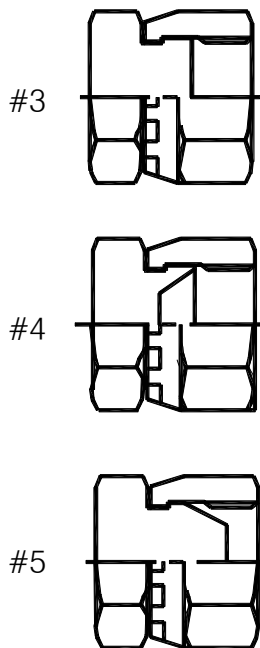

MODEL	TYPE	P/ N	TYPE	P/ N	O-RING(#3)
WHB20	# 5	2715002	# 4	C01152	-
WHB30	# 5	2715002	# 4	C01152	-
WHB35	# 5	2715002	# 4	C01152	-
WHB40	# 5	2715002	# 4	C01152	-
WHB43	# 5	2715002	# 4	C01152	-
WHB43B	# 3	2715062	# 4	C11149	2856003
WHB45	# 3	2715062	# 4	C11149	2856003
WHB50	# 3	2715062	# 4	C11149	2856003
WHB60	# 3	2715063	# 4	C21132	2856004
WHB70	# 3	2715063	# 4	C21132	2856004

2.3 Hydraulic pipe lines for exclusive use

Operation of the hydraulic breaker requires installation of hydraulic pipe lines for exclusive use of the hydraulic breaker. As hydraulic pipe lines vary depending on base machines, our service engineer must first check hydraulic pressure, oil capacity, pressure loss and other conditions of the base machine before installing hydraulic pipe lines. Use only genuine parts in case of replacement because hydraulic pipe lines(hoses, pipes and fittings) are made of materials carefully selected in consideration of durability.



WARNING

THE HYDRAULIC SYSTEM TO THE BASE MACHINE MUST BE CHECKED BY AN AUTHORIZED SOOSAN SERVICE ENGINEER BEFORE FIRST USE AND AFTER ANY MODIFICATIONS.



WARNING

MAKE SURE THAT THE HYDRAULIC BREAKER VALVE OF HYDRAULIC SYSTEM IS PROPERLY SET.

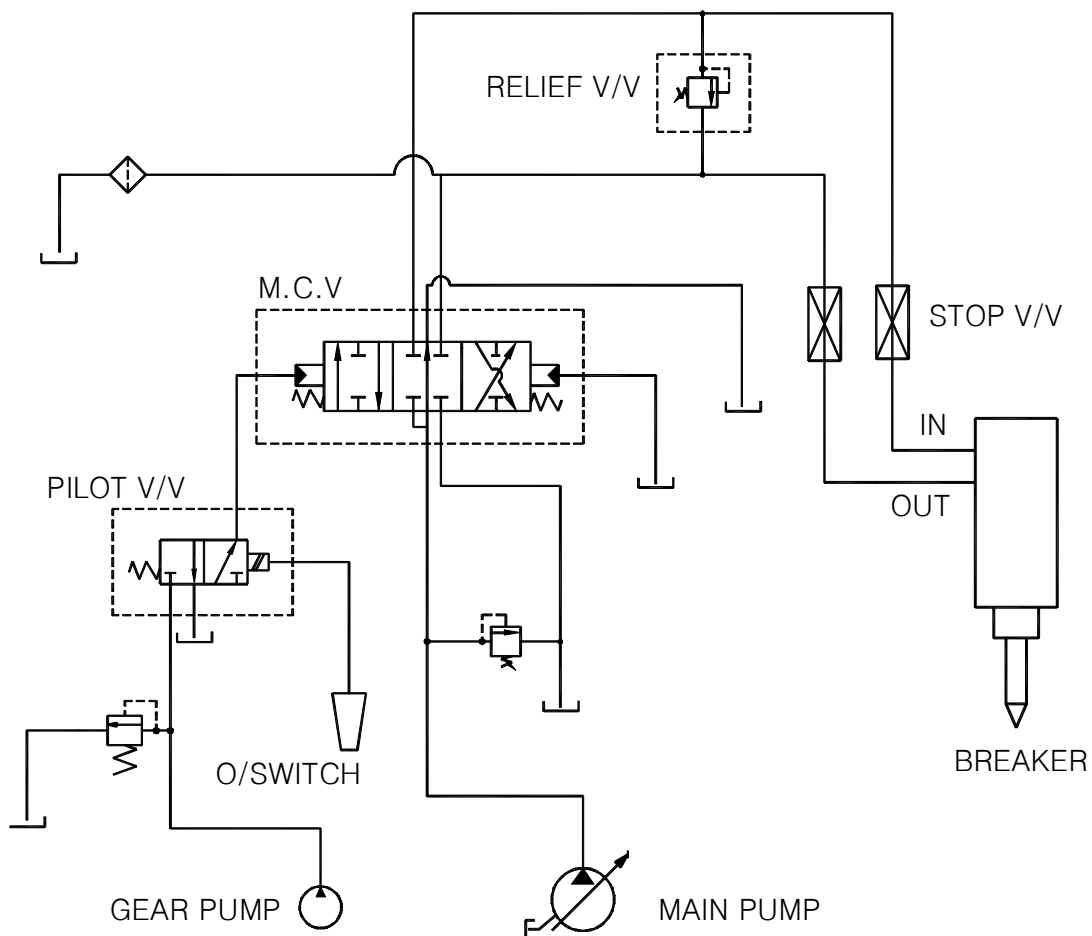

03. Precautions for safe operation.

[1] Proper position must be applied for an effective usage of breaking force.

When position is incorrect, hammering energy of the piston is too weak to break rocks, Instead, hammering force applies shocks to the breaker body, breaker arm and boom of the base machine, thereby resulting in damage to those parts.

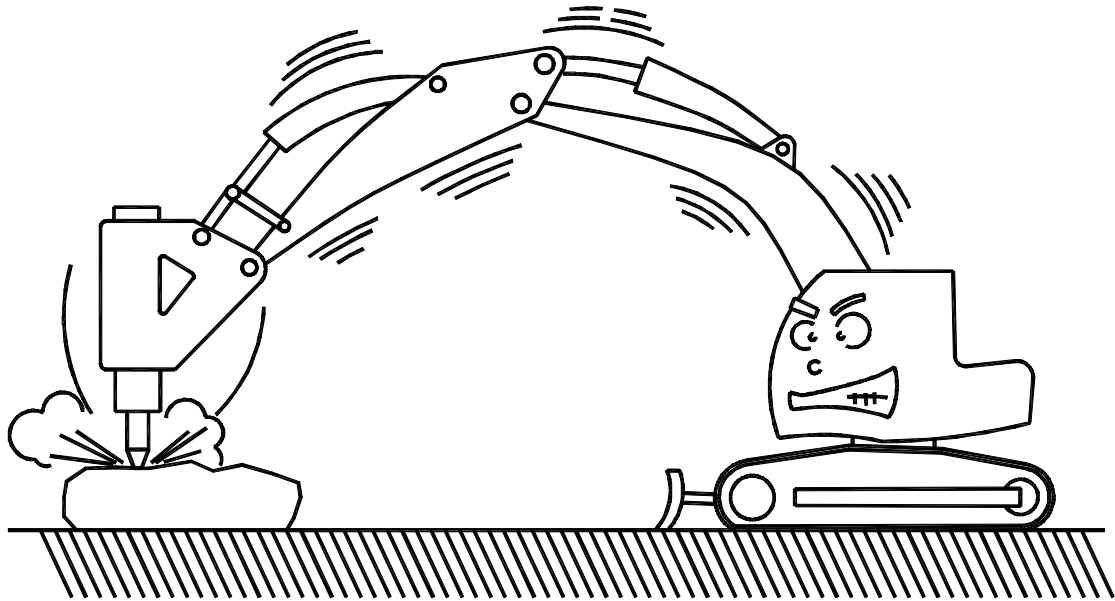

[2] On the contrary, when position is excessive enough to break rocks with front of the base machine raised, the machine may suddenly tilt forward the moment rocks are broken. Then, the breaker body or the end of bracket may violently hit against rocks and result in damage.

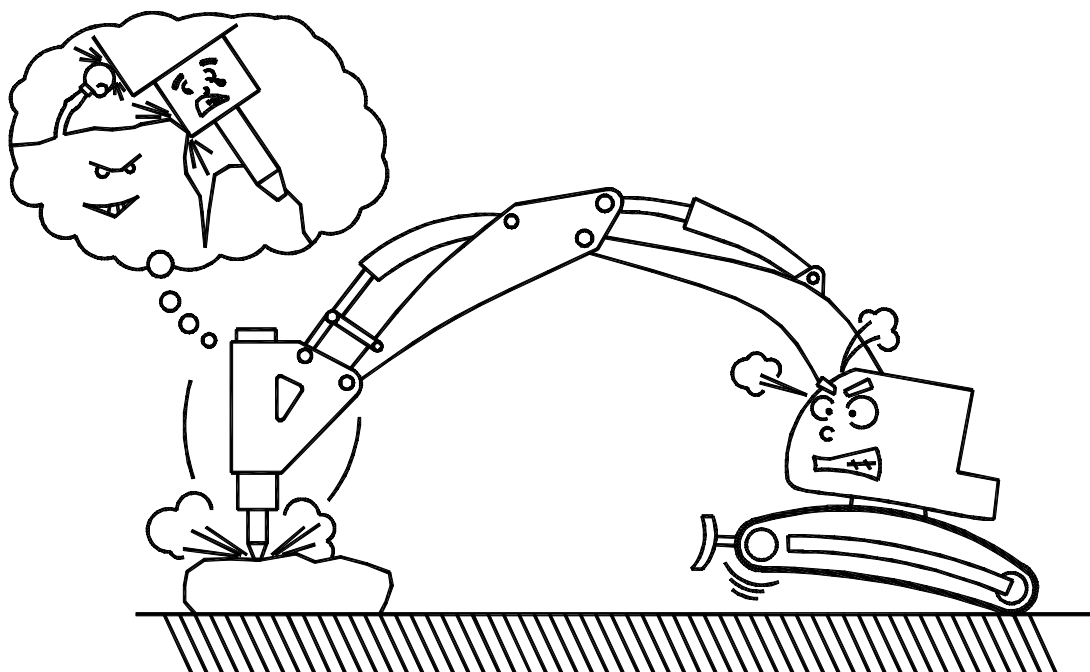

- [3] It is undesirable to carry out hammering under the below condition, because vibrations during hammering may be transmitted to tracks of the base machine. During hammering, however, proper position must be always applied to the breaker. Special care must be taken not to hammer under abnormal condition.

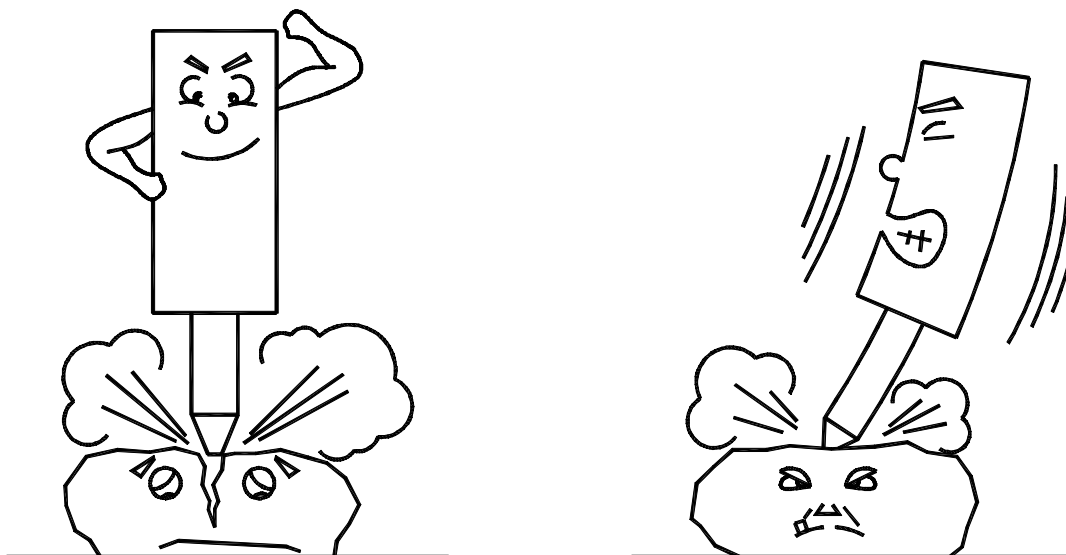

- [4] Apply same direction of boom force in line with the rod and place the rod in the rock with hammering surface as vertical as possible. If hammering surface is oblique, the rod may slip during hammering. This causes the rod to seize and to be broken and piston to be damaged. When breaking, fully stabilize the rod first and then select the point of a rock on which hammering can be performed in a stable condition.

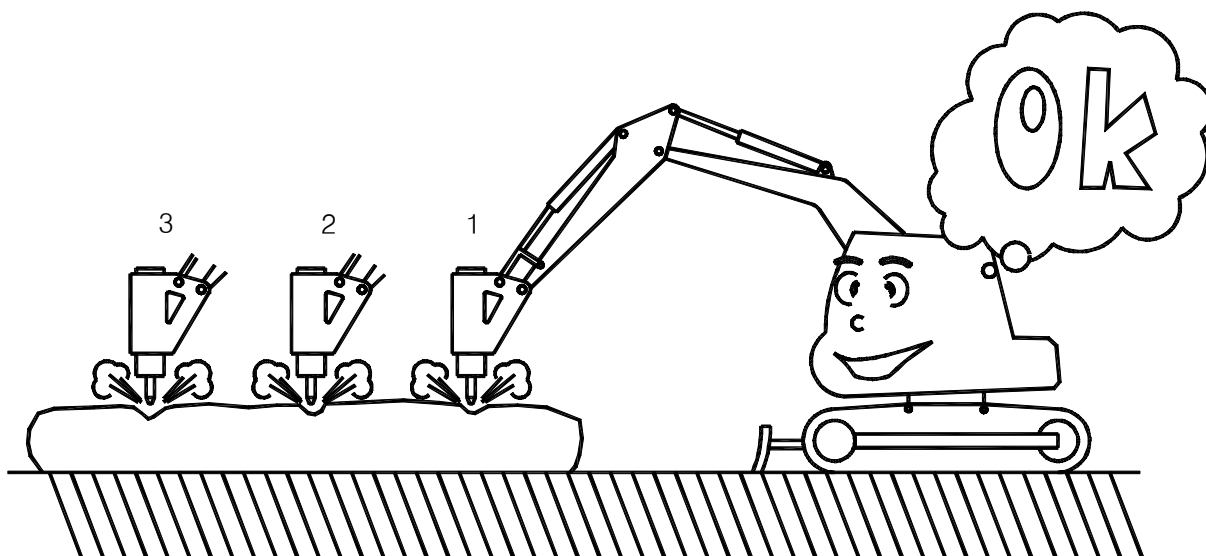

- [5] Rolling or falling a rock with the rod end or bracket side by using the boom or arm of the carrier as shown in the figure will result in breakage of the breaker mounting bolt or bracket, breakage and galling of rod, and damage to the arm and boom. Do not move rock. It is strictly prohibited to travel when the breaker is in the contact with rock.

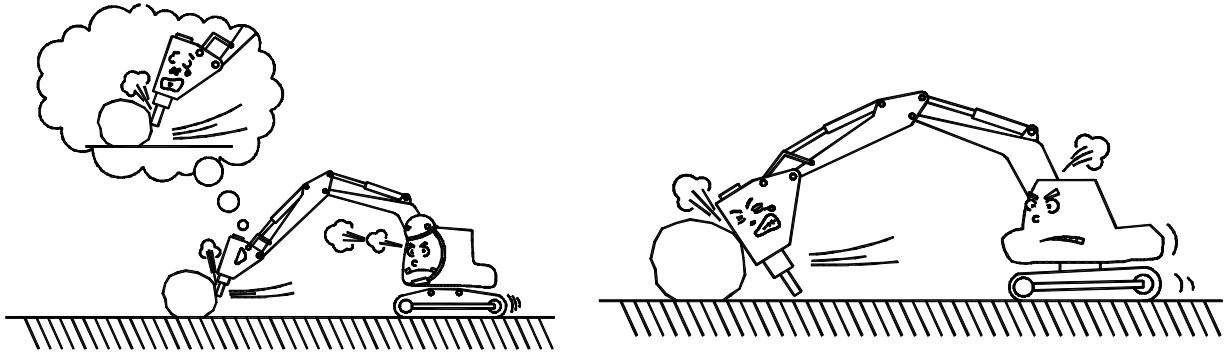

- [6] Do not use rod as a lever. Do not put the rod into a crack in rock and move the rod to and fro to breaker the rock, otherwise the rod will be broken or the bracket will be damaged.

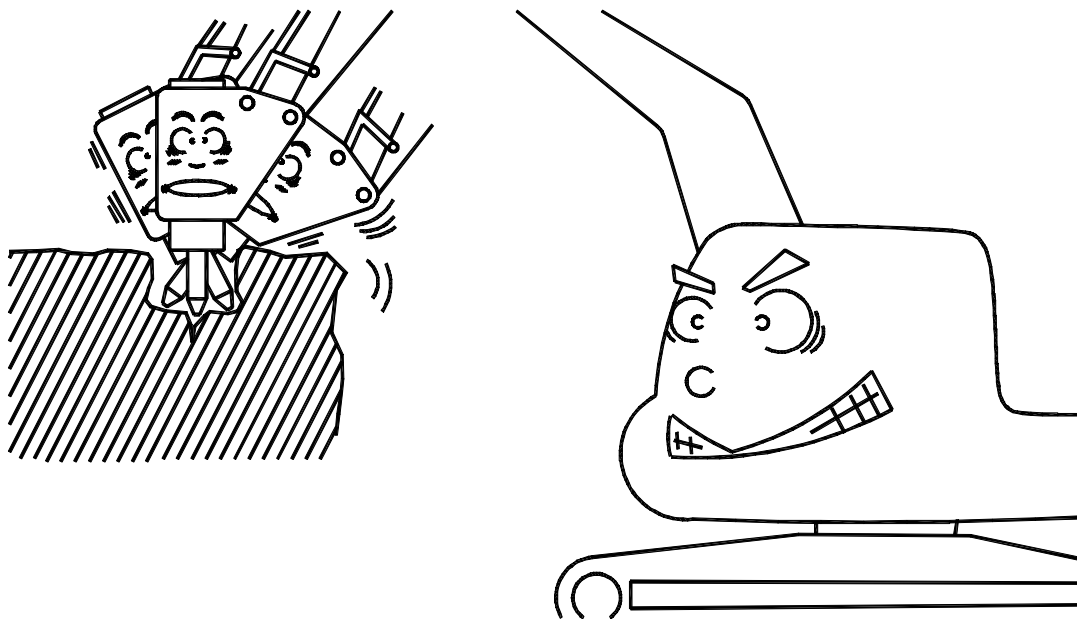

- [7] Do not operate breaker when all components except rod are immersed in water and mud.
Underwater usage of the breaker will cause internal damage to the breaker.
Consult Soosan for modifications if you have an underwater requirement.

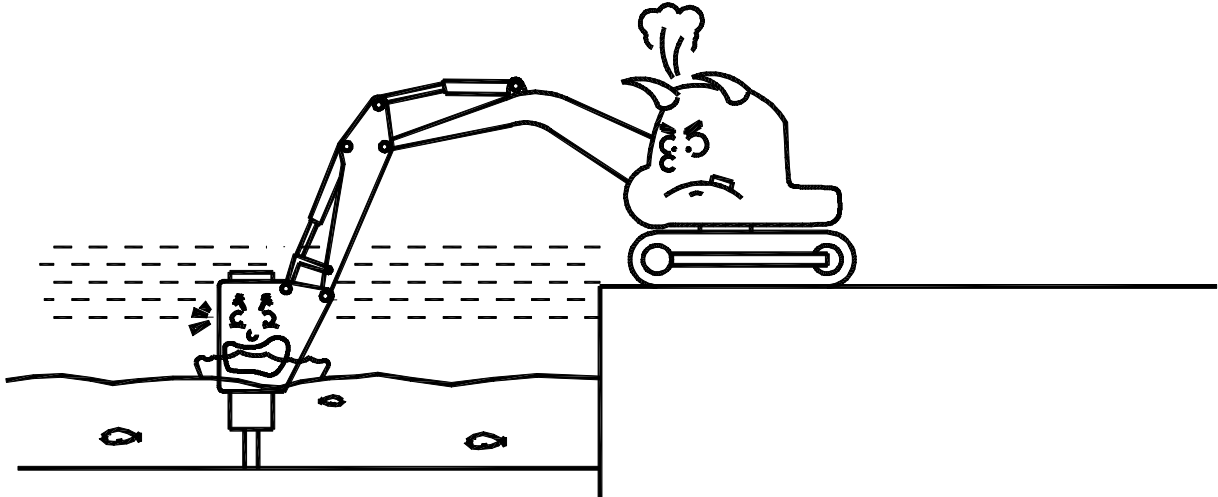

- [8] Do not allow the breaker to fall to a rock.
Falling down the breaker will apply excessive force to the breaker or the carrier, causing damage to the parts of the breaker and carrier.

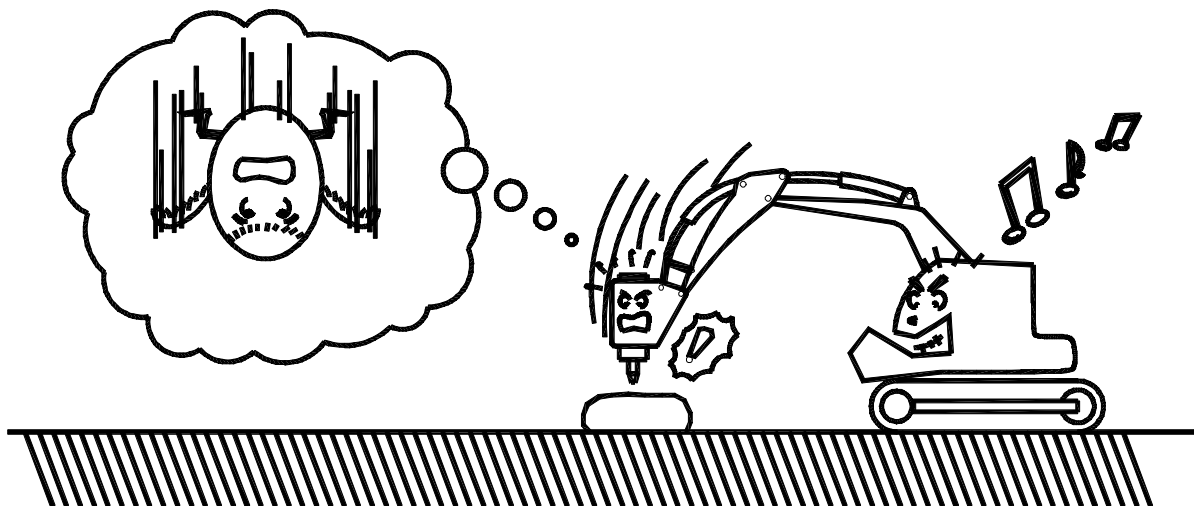

- [9] Breaking operation conducted at the stroke end (when the cylinder is extended or retracted to a maximum extent) of respective hydraulic cylinders of the carrier will lead to damage to the cylinders and other parts of the carrier.

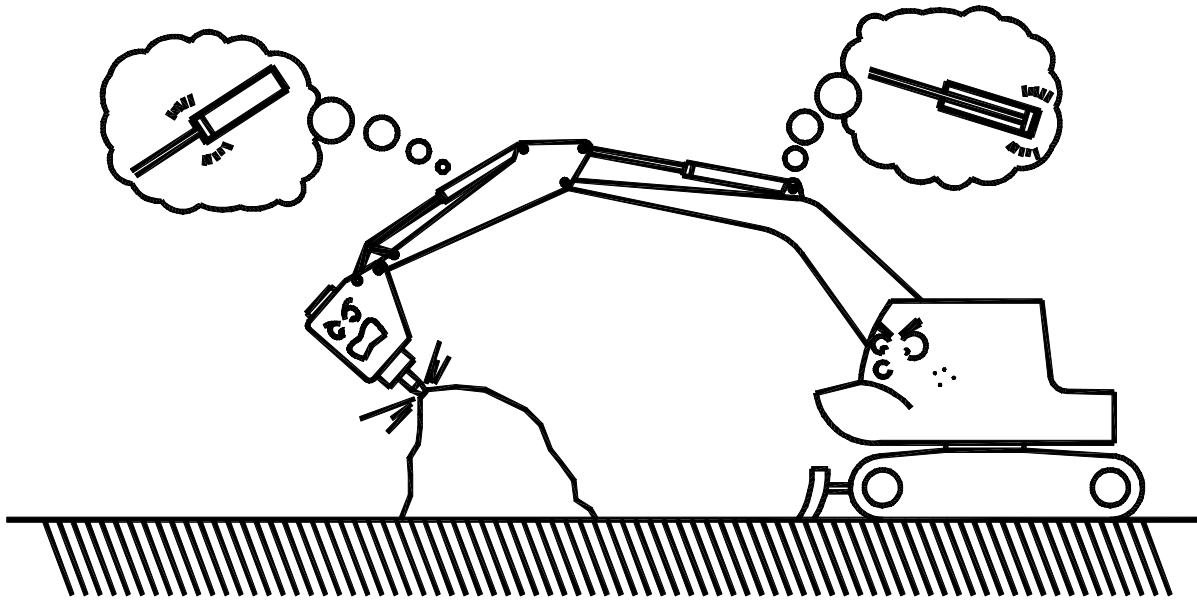

- [10] Lifting thing by hanging wire in the bracket or rod not only causes damage to the breaker but also is very dangerous.

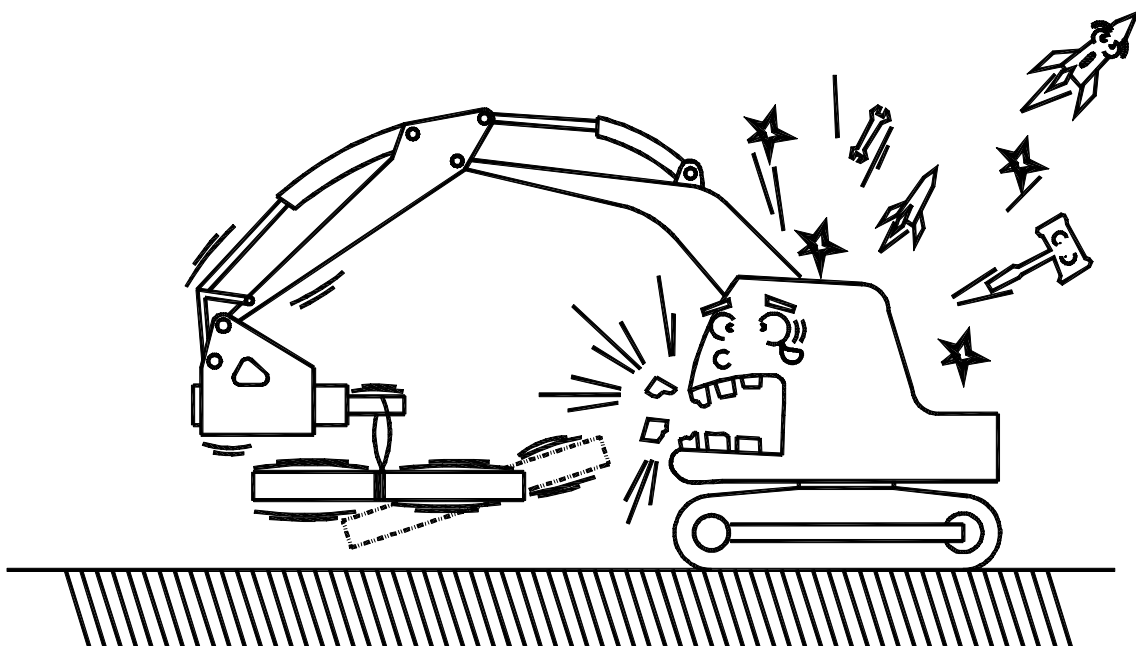

- [11] Warm-up of machine prior to operation
- Do not operate the machine right after starting the engine. Idle the machine for warm-up. Warm the hydraulic oil sufficiently especially in winter or in the cold place.
 - Especially in winter, the carrier's engine should be warmed up for 5 to 10 minutes 30~40°C (86~105°F) before breaker operation.
 - When operating the hydraulic breaker, idle the engine and operate the hydraulic breaker with a light load.
- [12] Stop operation when hoses are vibrating abnormally.
- Check the hoses on the high pressure and low pressure sides of the breaker for abnormal vibration. If they are vibrating abnormally, contact the nearest Soosan dealer.
- [13] Avoid blank hammering.
- Blank hammering accelerates wear and tear on breaker and carrier components and may result in failure of one or more components. Excessive blank hammering may be considered equipment abuse and may result in voiding warranties. In case of blank hammering, hammering sound changes.
- [14] Operate the breaker at proper engine speed.
- Break rocks at the specified engine speed. Raising engine speed more than necessary does not strengthen hammering force but increase oil temperature to the detriment of piston and valve.

04. Maintenance

■ Regular Hydraulic breaker Inspection and Maintenance



Regular inspection is essential for keeping hydraulic breaker operating in the best condition consult with the Soosan service station for regular inspection and maintenance. Customers are recommended to contact the service station for inspection within six months after delivery.

■ Maintenance of Hydraulic breaker

Check cycle	Check Item	Location
Ordinary check items before and after operating breaker	<ul style="list-style-type: none"> ● Confirm the state of setting breaker and carrier <ul style="list-style-type: none"> * Damage and assembled state of bracket pin * Fastened state of pin assembled bolts * State of quick-clamp setting and bolts/pins assembled * State of cap mounting bolt(TOP Type) 	
	<ul style="list-style-type: none"> ● Assembling state of breaker and bracket <ul style="list-style-type: none"> * State of side-bolt and all kinds of bolt * Whether all kinds fixing part and anti-shock parts (cushion & wear plate)are damaged * State of bracket-crack, breakage, welded area 	E
	<ul style="list-style-type: none"> ● Fastening state of breaker main-body parts <ul style="list-style-type: none"> - Fastening and breakage state of pins, blocks, bolts * Fastened through bolt state * Front head pin and Rubber plugs * Stop pin and Rubber plugs * Air check valve * Back head charging valve * Valve adjuster * Accumulator mounting bolt * Accumulator cover fastening bolt * Accumulator charging valve * Hose adapter * Hex Head Plug 	A G F H B C D I J
	<ul style="list-style-type: none"> ● Damage of safety/warning sticker 	
	<ul style="list-style-type: none"> ● Loss or fastening state of bracket assembled parts <ul style="list-style-type: none"> * Sound plug(Silenced type) * Window cover(Silenced type) * Hose cover(Silenced type) 	
	<ul style="list-style-type: none"> ● Leakage, interference and assembling state of carrier hoses and pipes <ul style="list-style-type: none"> * Interference and assembling state of hoses and pipes * Fixing state of control valve * Welding state of clamps * Leakage and fastening state of pipes/hoses connected * Whether hose are twisted/damaged/aged 	
	<ul style="list-style-type: none"> ● Oil tank and working fluid quality <ul style="list-style-type: none"> * Quantity of working fluid * Contamination of working fluid 	
	<ul style="list-style-type: none"> ● Breaker on/off switch and electric wire 	
	<ul style="list-style-type: none"> ● Examine worsen state of consumable parts <ul style="list-style-type: none"> * Inside diameter of front cover * Worsen state of rod 	

Check cycle	Check Item	Location
Any time check items during operating breaker	<ul style="list-style-type: none"> ● Temperature of working fluid(below 80°C/176°F) ● Loss and damage of parts 	
	<ul style="list-style-type: none"> ● Leakage of breaker hoses <ul style="list-style-type: none"> – A little leakage could be run on the rod (as much as it does not affect operating, performance and efficiency) ● Efficiency and abnormal working of breaker <ul style="list-style-type: none"> * Irregular blowing is occurred * Abnormal blowing sound is occurred * Pipes and hoses are shaken extremely 	
After 1Hr operating	<ul style="list-style-type: none"> ● Grease pumping(about 20cc after 1hr operating) <ul style="list-style-type: none"> – About 5~10 times pumping with grease gun * Rod friction area : Ring bush, Front cover, Rod pin 	
Every week (Every 50hr operating)	<ul style="list-style-type: none"> ● Quantity and contamination degree of working fluid(Refill or replace) <ul style="list-style-type: none"> * Contamination limit : 20~40cst ● Examining wear of consumable parts (Grind the area deformed if necessary) <ul style="list-style-type: none"> * Rod pin * Ring bush * Front cover ● Remove strange material inside of front head ● Check the gas pressure and refill <ul style="list-style-type: none"> * Back head * Accumulator 	
	<ul style="list-style-type: none"> ● Whether all kinds of bolts are fastened by regulated torque 	
	<ul style="list-style-type: none"> ● Operating pressure of breaker ● Relief setting pressure of hydraulic circuit ● Supply flow ● Replace oil filter of carrier 	
	<ul style="list-style-type: none"> ● Replace seal kit ● Replace diaphragm of accumulator ● Examine if piston is pressed or deformed ● Examine if hydraulic parts are scratched if necessary grind and repair them 	
Every month (Every 200 Hr operating)	<ul style="list-style-type: none"> ● Sufficient greasing <ul style="list-style-type: none"> * Rod, Rod pin, Front cover, Ring bush ● Lubricate piston surface ● Remove N₂ Gas <ul style="list-style-type: none"> * Back head * Accumulator ● Paint area fallen off 	
	<ul style="list-style-type: none"> ● Clean and grease after disassemble all parts of main body 	
Hold breaker over 1month	<ul style="list-style-type: none"> ● Sufficient greasing <ul style="list-style-type: none"> * Rod, Rod pin, Front cover, Ring bush ● Lubricate piston surface ● Remove N₂ Gas <ul style="list-style-type: none"> * Back head * Accumulator ● Paint area fallen off 	
After under water operating	<ul style="list-style-type: none"> ● Clean and grease after disassemble all parts of main body 	

* The maintenance related with carrier follows carrier manufacturer rule

■ Daily Inspection before operating

Be fore starting operation, be sure to inspect the breaker referring to the following table.

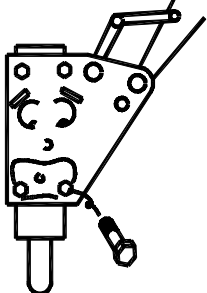
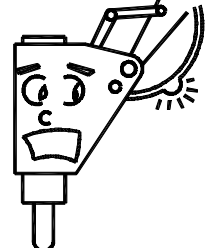
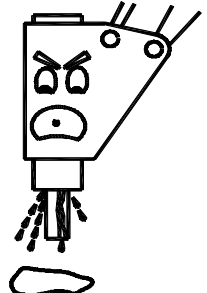
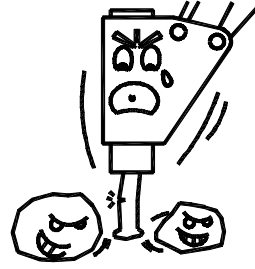
Inspection Item	Inspection Point	Remedy
<ul style="list-style-type: none"> - Looseness, missing and damage to bolts and nuts 	<ul style="list-style-type: none"> - Through bolt - Bracket mounting bolt 	<ul style="list-style-type: none"> - Check looseness. - Retighten to correct Tightening torque.
<ul style="list-style-type: none"> - Looseness of hose fittings, visible damage to hoses & oil leakage 	<ul style="list-style-type: none"> - Hydraulic piping for breaker - Oil hose 	<ul style="list-style-type: none"> - Retighten sufficiently. - Replace when damaged.
<ul style="list-style-type: none"> - Abnormal oil leakage 	<ul style="list-style-type: none"> - Connection of back head and cylinder - Gap between front head and rod * But small leakage is normal. 	<ul style="list-style-type: none"> - Consult with Soosan for further inspection.
<ul style="list-style-type: none"> - Abnormal wear and cracks rod. 	<ul style="list-style-type: none"> - rod 	<ul style="list-style-type: none"> - If the rod is deformed, burred and worn out, be repaired. - If the rod is excessively worn out, be replaced. - If the rod is cracked, be replaced.

■ Tightening Torque & Gas Pressure

MODE ITEM	Position	UNIT	WHB10	WHB20	WHB30	WHB35	WH40	WHB43	WHB43B	WHB45	WHB50	WHB60	WHB70
			WHB20	WHB30	WHB35	WH40	WHB43	WHB43B	WHB45	WHB50	WHB60	WHB70	
Through Bolt Nut	A	kg-m	25~30	25~30	30~35	38~42	60~70	60~70	96 ~105	140 ~150	190 ~200	270 ~280	
Accumulator Socket Bolt	B	kg-m	-	-	-	-	-	-	-	-	-	-	
Accumulator Cover Socket Bolt	C	kg-m	-	-	-	-	-	-	-	-	-	-	
Cap & Plug	D	kg-m	-	-	-	-	15						
Bracket Fixing Bolt	E	kg-m	60	80	80	100	100	100	145	145	200	250	
Back Head Gas Pressure	F	kg/cm ² (psi)	16 (235)	16 (235)	16 (235)	16 (235)	16 (235)	16 (235)	16 (235)	16 (235)	16 (235)	16 (235)	16 (235)
Accumulator Gas Pressure	D	kg/cm ² (psi)	-	-	-	-	-	10 (142)	-	-	-	-	-
Air check valve	G	kg-m	16~18	16~18	16~18	16~18	16~18	16~18	16~18	16~18	16~18	16~18	16~18
Valve Adjust Nut	H	kg-m	-	-	-	-	-	25~30	-	-	25~30	30~35	
Adapter	I	kg-m	16~18	16~18	16~18	16~18	16~18	16~18	24~26	24~26	32~35	32~35	
Charging Valve	F	kg-m	35~40	35~40	35~40	35~40	35~40	35~40	35~40	35~40	35~40	35~40	35~40
Hex Head Plug	J	kg-m	-	-	-	-	-	-	-	-	3~4	3~4	
Greasing every 1 Hr Using (Manual)	*	cc	7	7	7	10	10	10	10	15	15	20	

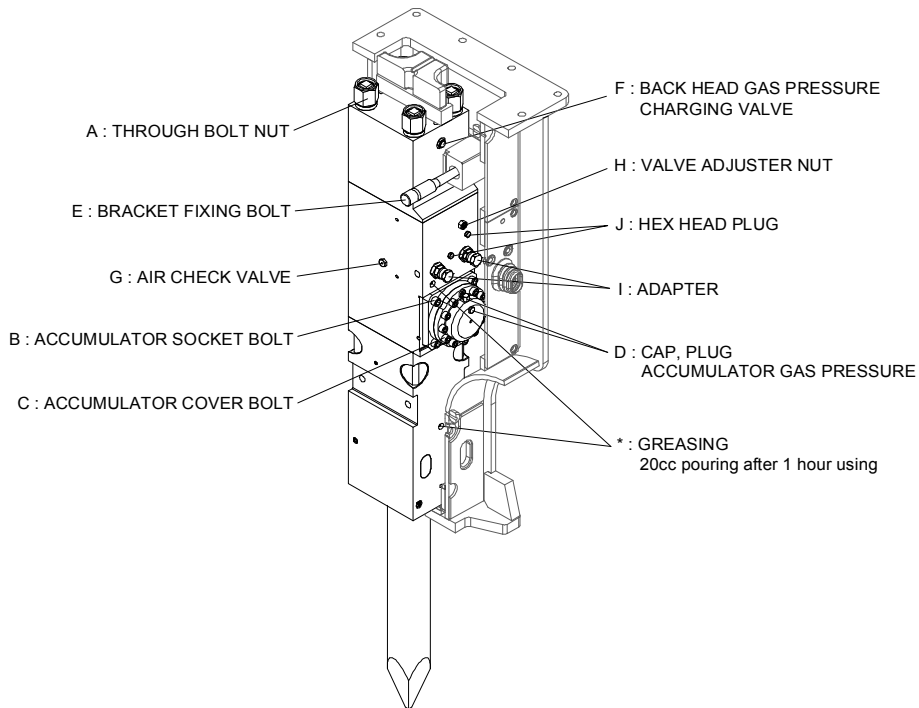

■ Replacement & Breakage of Rod

- Rod is deformed or burrs produced in a long term use.
- If the rod tip is worn out, rod is liable to slip. Grind the rod tip to sharpen the edge.
- If the rod tip is sharpened many times, the hardened surface layer will disappear and the rod will be worn out rapidly. In this case, replace with a new rod.
- If the gap between rod and front cover is large, the piston fail to fit in rod to cause damage to the piston or the rod.

● Replacement

- ① Put the breaker horizontally on the timber.
- ② Remove the spring pin(SB43 below) or rubber plug(SB45 above) using a pin bar.
- ③ Set round bar on the opposite side, and push the stop pin with a hammer.
- ④ Remove the rod pin. In removing the rod pin, be careful falling of rod and rod pin.
- ⑤ Wind rope or nylon sling around the rod and remove from the main body.
- ⑥ Before installing a new rod, check wear, breakage and score.
Remove burrs and swelling from the disassembled rod pin with a grinder. Excessively deformed rod pin will make replacement of rod difficult. Rod pin is required to be checked every 100 to 150 hours of operation
- ⑦ Grease sufficiently to inserting part of front head.

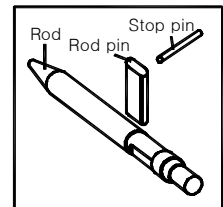
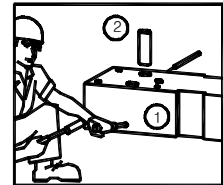

● Breakage of Rod

The service life of the rods depends on the manner of handling them. The rod can sufficiently withstand the vertically acting load, but is weak to the perpendicularly acting load. Especially, the rod is affected by the negative conditions such as force by craning operation, tilted blowing, wrenching and idle strokes etc. There are several ways of breakage of the rod. Each cause of the breakage can be inferred by observing the breakage section. Further, the breakage case which is not caused by low quality materials or insufficient heat-treatment but by wrong way of handling which the manufacturer is not responsible for the breakage. The breakage section has the origin on the outer surface, the narrow area of fatigue breakage and the wide area of rough grey area, and final breakage part has the share-lip form. Such as undulation on the breakage section and its inclination to the right and left witness that the breakage is caused by excessive force which exceeds the toughness of the rod. Such the breakage is supposed to occur owing to careless handling of the rod. To avoid such the breakage more carefulness and attention is required in handling the breaker.

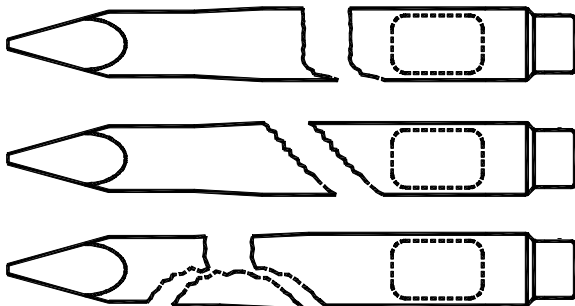

Typical fractures caused by excessive bending of the rod. Warranty claims rejected.

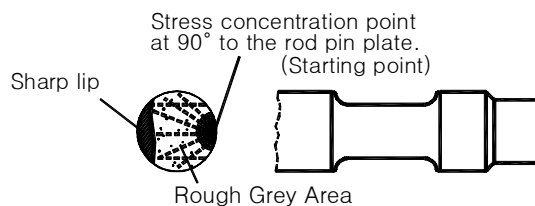

Typical fractures caused by levering tool while buried in the burden. Warranty claims rejected.



Flat type rod worn more than 45mm or moil type and wedge, universal type rods worn back more than 75mm of working end classed as reasonable life. Warranty claims rejected.

05. Inspection and Charging of N₂ Gas at Back head



WARNING

Charging gas pressure changes according to the rod condition.

Lay down the hammer and let the rod extend fully to charge gas.

Stay clear of the rod while charging the breaker with gas.

The rod may be impacted by the piston and forced out abruptly, when the through bolts are changed or the breaker body is disassembled. Discharge N₂ gas before work.

Take special care to handle and store the N₂ gas cylinder as it is high pressurized container.

Use nitrogen gas only.

Back head gas pressure 6kg/cm² (85.5psi) on the back head surface temperature at 20°C(68°F)

See "CONVERSION TABLE FOR CHARGING N₂ GAS PRESSURE TO BACK HEAD"

■ Inspection of N₂ Gas Back Head

- 1) Make sure if the cap and valve of the 3-way valve assembly(5) are fully tightened.
Screw the 3-way valve assembly(5) into the charging valve of the back head after removing the plug.
- 2) At this time the handle must stand up to prevent the gas from coming out.
- 3) Push the handle into the charging valve fully, so the gas pressure inside the back head is indicated on the pressure gauge.
- 4) When the gas pressure is normal, unscrew the 3-way valve assembly after discharging gas inside the 3-way valve assembly.
- 5) When the gas pressure is higher or lower, charge it as described below.

■ Charging of N₂ gas into Back Head

- 1) Connect the charging hose(4) to N₂ gas cylinder(1) after screwing the bombe adapter(3) onto adapter nut(2) and installing them to the N₂ gas cylinder.
- 2) Connect the 3-way valve assembly(5) to the charging hose(4) after unscrewing the cap on the 3-way valve.
- 3) Install the 3-way valve assembly(5) to the charging valve of the Back Head. At this time the handle of the 3-way valve assembly must be up position to prevent the gas from coming out.
- 4) Push the handle of the 3-way valve assembly fully and turn the handle of the N₂ gas cylinder counterclockwise gradually to charge gas.
- 5) When the gas pressure exceeds 10% higher than the specified pressure, close the N₂ gas cylinder by turning the handle clockwise.
- 6) Leave the handle of 3-way valve assembly up. Generated pressure makes it return back to original position naturally.
- 7) In order to discharge N₂ gas in the charging hose(4) and the 3-way valve assembly turn the relief valve counterclockwise.
- 8) Remove the charging hose(4) from the N₂ gas cylinder(1) and the 3-way valve assembly(5), and screw the cap into the 3-way valve assembly.
- 9) Push the handle of the 3-way valve assembly fully, and the gas pressure inside the Back Head is indicated on the pressure gauge. When the pressure is higher, discharge a small amount of gas from the Back Head by repeatedly opening and closing the valve and then gas pressure falls to the specified pressure.
- 10) When the gas pressure reaches to the specified pressure, close the valve and release the handle.
- 11) Open the valve completely and discharge gas inside the 3-way valve assembly.
Remove the 3-way valve assembly from the charging valve of Back Head and install the plug to the charging valve. At this time prevent contamination from entering the breaker.

■ Conversion Table for charging nitrogen gas pressure to Back Head

(Depends on the temperature of Back Head surface)

Back Head Surface Temperature (°C / °F)	0 / 32	10 / 50	20 / 68	30 / 86	40 / 104
Back Head Gas Pressure (kg/cm ² / psi)	15,5 / 220	16 / 228	16,5 / 235	17 / 242	17,5 / 249

■ Back Head Sticker (C02135)

(Appears on the Back Head charging valve)

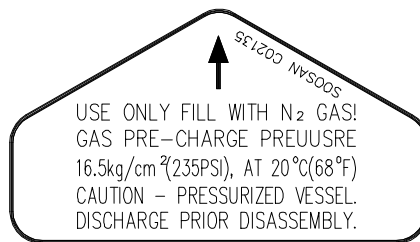

■ N₂ (Nitrogen) Gas charging tools to Back Head

ITEM	PART No.	Q'ty	PART NAME
	C61204	1 SET	N ₂ (Nitrogen) Gas Charging Set
1	2900003	1	N ₂ (Nitrogen) Gas Cylinder
2	C91121	1	Bombe Adapter Nut
3	C91122	1	Bombe Adapter
4	2651001	1	Synflex Hose
5	C01244	1	B-3way Valve Assembly

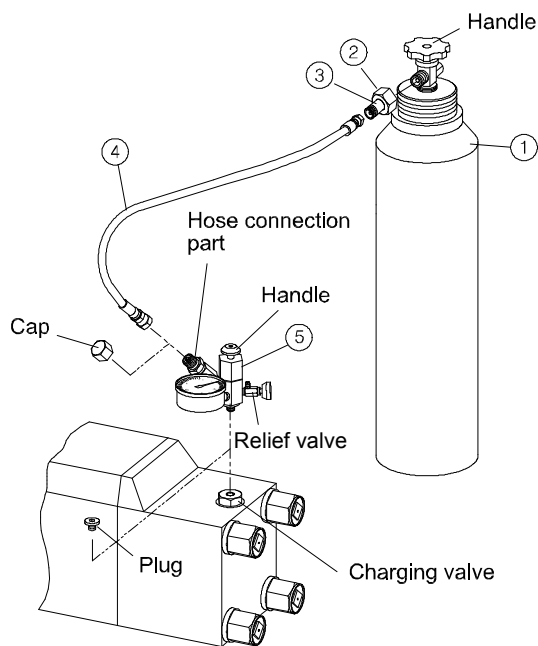

Conversion table for charging N₂ gas pressure to back head

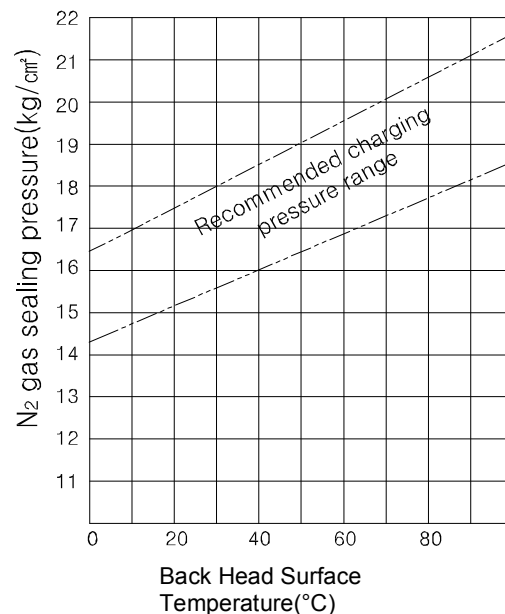

06. Inspection and Charging of N₂ gas in Accumulator



WARNING

Take special care to handle and store the N₂ gas cylinder as it is high pressurized
Use nitrogen gas only.

When disassemble the accumulator, must discharge N₂ gas before working.

Do not touch on the accumulator surface when working.

Be sure to use the 3 way valve assembly for charging the N₂ gas if charging gas leaks directly from the cylinder, diaphragm may be broken off.

If charging for handling N₂ gas to only the accumulator, make sure that the accumulator body and cover are tightened fully.

Standard accumulator gas pressure 55kg/cm² (783psi) on the accumulator surface temperature at 20°C(68°F)

See "CONVERSION TABLE FOR CHARGING N₂ GAS PRESSURE TO BACK HEAD"

■ Inspection of N₂ gas Accumulator.

- 1) Make sure if the cap and valve of the 3-way valve assembly(5) are fully tightened.
- 2) Remove the cap(11) from the accumulator and tighten the charging valve (12) fully.
- 3) Check if O-rings(6)(8) are installed to the bushing(7). Remove the plug(9) and screw the bushing.
- 4) Install the bushing(7) to the 3-way valve assembly(5).
- 5) Loosen the charging valve(12) gradually. The charging pressure is indicated on the pressure gauge.
- 6) Close the valve clockwise when the gas pressure is normal. If the gas pressure is higher, repeat loosening and tightening the relief valve of 3-way valve assembly. The pressure is lowered gradually.
- 7) Loosen the relief valve of the 3-way valve assembly to discharge the N₂ gas in the 3-way valve assembly(5).
- 8) Remove the 3-way valve assembly(5) and tighten the plug(9) and cap(11).

■ Charging of N₂ gas into Accumulator

- 1) Connect the charging hose(4) to N₂ gas cylinder(1) after screwing the bombe adapter(3) onto adapter, nut(2) and installing to the N₂ gas cylinder.
- 2) Connect the 3-way valve assembly(5) to the charging hose(4) after unscrewing the cap on the 3-way valve assembly.
- 3) Remove the cap(11) from the accumulator and tighten the charging valve(12) fully.
- 4) Check if O-rings (6)(8) are installed to the bushing(7). Remove the plug(9) and screw the bushing.
- 5) Loosen the accumulator charging valve(12) after checking if bushing(7) is installed to the 3-way valve assembly.
- 6) Turn the handle of the N₂ gas cylinder counter clockwise slowly to charge gas.
- 7) Charge gas in accordance with the conversion table for charging N₂ gas pressure to accumulator.
- 8) Turn the handle of the N₂ gas cylinder clockwise to close the cock.
- 9) Close the accumulator charging valve(12).
- 10) Loosen the relief valve of the 3-way valve assembly to discharge the N₂ gas remaining in the charging hose.
- 11) Remove the charging hose, 3-way valve assembly and bushing and tighten the plug(9) and cap(11).

■ Conversion Table for charging nitrogen gas pressure to Accumulator

Accumulator Surface Temperature (°C / °Fμ)	0 / 32	10 / 50	20 / 68	30 / 86	40 / 104
Accumulator Gas Pressure (kg/cm ² / psi)	51 / 730	53 / 755	55 / 780	57 / 815	59 / 830

■ N₂ (Nitrogen) gas Charging Tools to Accumulator

ITEM	PART No.	Q'ty	Part Name
1	2900003	1	N ₂ Gas Cylinder
2	C91122	1	Bombe Adapter
3	C91121	1	Bombe Adapter Nut
4	2651001	1	Synflex Hose
5	C01244	1	B-3 Way Valve Assembly
6	2850010	1	O-Ring
7	U81414	1	O-Ring Hex Bushing
8	2850014	1	O-Ring

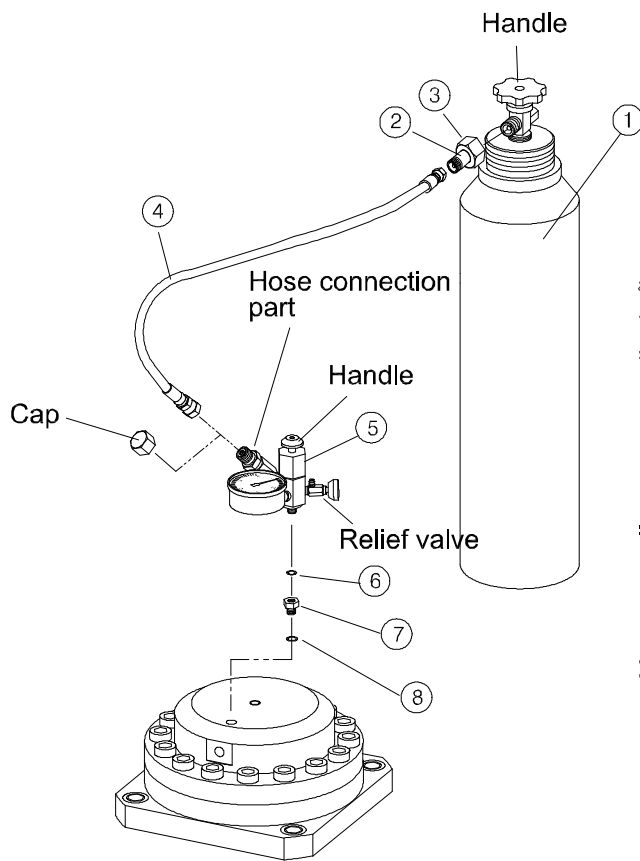

Conversion table for charging N₂ gas pressure to accumulator

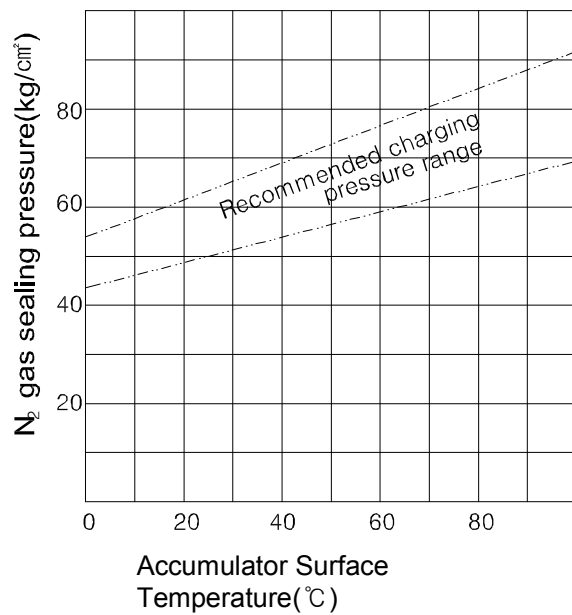

07. Trouble Shooting

The trouble-shooting chart is prepared to help operators find out causes and remedies instantly when troubles occur. When a trouble is found, have a good grip of the problem and contact our service station. When diagnosing faults in operation of the breaker, always check that hydraulic power source is supplying the correct hydraulic flow and pressure to the breaker as listed in the table. Check the flow with the hydraulic oil temperature at least 176°F/80°C. An approved test procedure is available from Soosan.

TROUBLE	CAUSE	REMEDY
<p>1. Breaker fails to hammer</p> <ul style="list-style-type: none"> * Sufficient high pressure oil does not flow to breaker inlet. * Sufficient high pressure oil flows to breaker inlet. 	<ul style="list-style-type: none"> * Defective hose or pipes * Clogged or damaged piping * Defective control valve and related parts * Insufficient hydraulic oil * Internal breaker defects 	<ul style="list-style-type: none"> * Check, clean and repair piping or replace with new one. * Check and repair valve and its related parts or replace with new one. * Refill oil tank. * Consult with our service station.
<p>2. Breaker hammers with hammering force reduced.</p> <ul style="list-style-type: none"> * Sufficient high pressure oil does not flow to breaker inlet. * Sufficient high pressure oil flows to breaker inlet. 	<ul style="list-style-type: none"> * Defective hose or pipes * Clogged piping, Oil leakage * Defective control valve and related parts * Deformed pedal * Deformed control valve * Stuck control valve * Insufficient control valve stroke due to loose screws * Clogged filter in return line of base machine tank * Insufficient hydraulic oil * Contaminated or deteriorated hydraulic oil * Defective pump * Internal breaker defects * low N₂-gas pressure of back head 	<ul style="list-style-type: none"> * Check, clean and repair piping or replace with new one. * Check control valve and related parts or replace with new one. * Clean or replace. * Refill. * After flushing tank, change oil entirely. * Ask service station for base machine service. * Consult with our service station. * Adjust the gas pressure referring to Chapter 10.
<p>3. Hammering force weakens suddenly and high pressure hose vibrates excessively during operation.</p>	<ul style="list-style-type: none"> * Defective Back Head Gas leakage 	<ul style="list-style-type: none"> * Ask our service station for repair.
<p>4. Excessive oil leakage from Front Head or Rod.</p>	<ul style="list-style-type: none"> * Worn cylinder seals 	<ul style="list-style-type: none"> * Ask our service station for repair.
<p>5. Piston works but does not hammer.</p>	<ul style="list-style-type: none"> * Stuck in rod 	<ul style="list-style-type: none"> * Remove front parts and pull out rod. * Repair with a grindstone.

※ Ask base machine service station to repair defective base machine.

08. Hydraulic Oil

Selection of hydraulic oil determines the efficiency of the hydraulic breaker performance. Please consult with our service station under following conditions.

- (1) When used in special regions where climate is severe (extremely cold or hot weather)
- (2) When recommended brands of hydraulic oil are not available
- (3) When hydraulic oil supplied for the base machine differ from the recommended one.

■ Hydraulic Oil and Grease

Recommended for Hydraulic Grab by Soosan

LUBE & SPEC Manufacturer	HYDRAULIC OIL			GREASE
	SUMMER	WINTER	ALL SEASON	(MOS2)
	ISO VG 46	ISO VG 32	ISO VG 46	NLGI No2
	MOBIL DTE 25	MOBIL DTE 24	MOBIL DTE 15M	MOBIL GREASE SPECIAL
MOBIL	MOBIL SHC 525 *			MOBILITH SHC 220 *
	MOBIL EAL SYNDRAULIC 46 **			
LG-CALTEX	RANDOHD 46	RANDO HD 32	NEW RANDO HDCZ	MOLYTEX EP2
BP	ENERGOL HP46	ENERGOL HP32	ENERGOL HP46	-
SHELL	TELLUS 46	TELLUS 32	TELLUS T 46	RETINAX HDX-2

★: Synthetic Lubricant

★★: Environmentally Friendly Synthetic Lubricant

■ Oil Contamination

Contaminated oil results in malfunctions of the breaker as well as the base machine and causes damage to parts. Pay special attention to oil contamination.

Contaminated oil should be changed without delay. When changing oil, thoroughly wash oil tank, cylinder and pipes. Cleaning or replacing oil filter also requires check for oil contamination.

※ Replacement of filter : after first 50 hours and every 100 hours thereafter

※ Replacement of hydraulic oil : every 500 hours



Hydraulic oil Temperature and viscosity

Do operate the hydraulic breaker at oil temperatures from 20°C/68°F to 80°C/176°F.

Operation at higher temperatures can damage the internal components of the breaker and carrier there will result in reduced breaker performance.



■ Criterion of Oil Contamination and Malfunction

(General Analysis)

Analysis Item	Criterion	Causes and Effects when exceed the criterion
Adhesiveness	Within±10% (40°C cst)	Adhesiveness rarely decreases because of hydraulic oil, Entry of different kind of oil may reduce the adhesiveness which contributes to rising oil temperature , wear and scratch of bearing and gear and malfunction of hydraulic oil.
Oxidizing Level	Less than 0,3 (mg KOH/g)	Use of lubricating oil in a long period or in a high temperature (above 60°C) will oxidize it, Oxidizing level rises as oxidization proceeds, Sludge will be produced during the process and it leads to malfunction, corrosion and ageing.
Moisture	Less than 0,1(%)	Moisture causes rust, wear and scratch, Moisture of 0,3% goes considerably rusty and moisture of 0,5% occurs the damage of machine.

■ Criterion of Oil Malfunction by Hydraulic Oil Color
(Simple discrimination by ASTM color)

Hydraulic oil turns black as the breaker fails to display best performance. The old oil is assumed to be contaminated when there is a visual difference between the old new oil color and functions begin to deteriorate when hydraulic oil turns darker than the new oil color (ASTM number) by more than two.

09. The Auto Lubrication Kit(Option)

- Install the auto lubrication kit before using it.
- Use only recommended lubricant, if not the lubricant useless.
- For the sake of the auto lubrication, the grease adapter is supplied as standard parts.
- Don't lubricate excessively, the lubricant will be leaked through the air check valve.
- Don't use fluid grease, but use only recommended lubricant.

■ Installing the Auto lubrication kit

- 1) Clean surface area of the grease nipple hole on the Cylinder(or Front head).
- 2) Remove the Grease nipple form the Cylinder(or Front head).
- 3) Apply the O-ring to the G adapter and install it on the Cylinder(or Front head).
- 4) Connect the 1/4" Hose to the G adapter.

■ Grease Filling Quantity (when Auto Lubrication kit installed)

Model	No.	Part No.	Part Name
ALL MODEL	1	2851018	O-Ring
	2	C01 157	G-Adapter
	3	2551042	Hose
	4	2700403	Grease Nipple

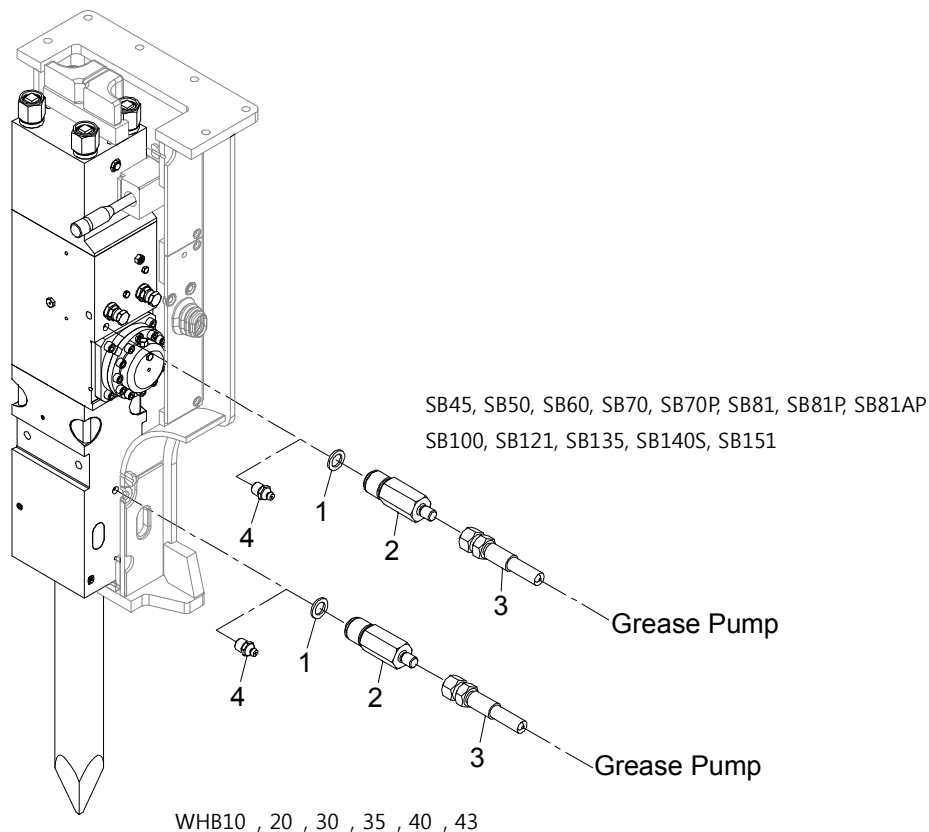

10. Underwater Operation of the Breaker(Option)

- Underwater operation of the breaker is possible to pour air into the striking area between the piston and the rod.
- For the sake of underwater operation the adapter is supplied as a standard part.
- For the sake of underwater operation the breaker is installed the air supply kit separately.
- Underwater usage of the breaker without the underwater kit and air compressor will cause serious damage to the hydraulic breaker.

■ Installing the Air supply kit

- 1) Clean the air check valve hole on the left-side of the cylinder.
(Except SB40, the air check valve hole is located on the right-side)
- 2) Remove the air check valve with the standard tool.
- 3) Apply the O-ring to the cylinder's air check valve hole and install it.
- 4) Connect the hose to the air check valve hole and install it.
- 5) Before underwater operation, the breaker get into water pouring air into air check valve.

■ Air flow rate for underwater operation

The air capacity levels are in the following chart. Supply appropriate air flow rate in accordance with the breaker model and operating depth.

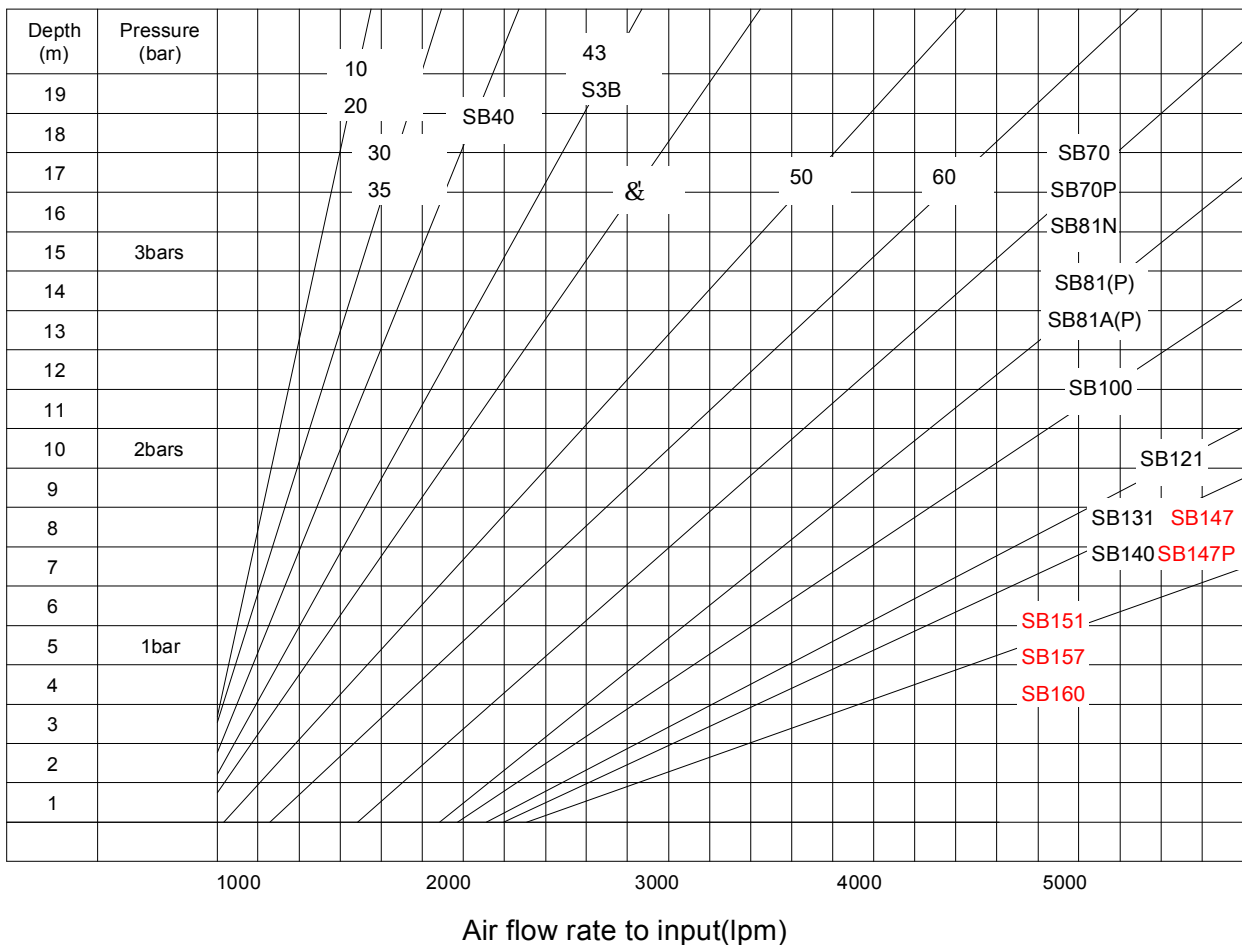

PARTS LIST

Hydraulic Breaker

Main Body

■ WHB10,20,30,35,40

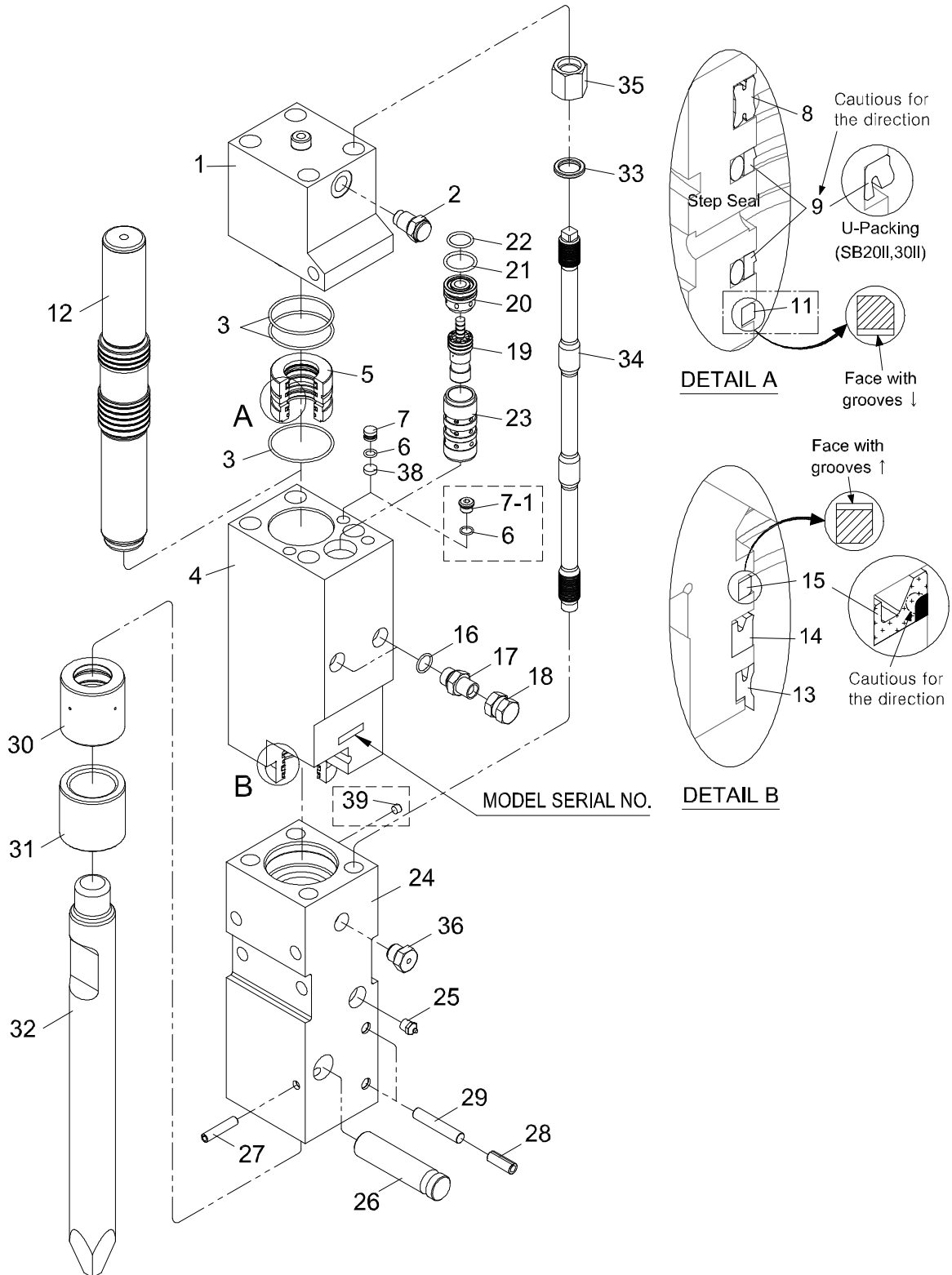

HYDRAULIC BREAKER PARTS LIST

■ MAIN BODY (WHB10,20,30,35,40)-----(#~) is applied Serial Number)

NO	WHB10 (#116~)		WHB20 (#532~)		WHB30 (#425~)		WHB35 (#95~)		WHB40 (#7116~)		WHB43 (#98~)		PARTS NAME	REMARK
	P/N	Q'ty	P/N	Q'ty	P/N	Q'ty	P/N	Q'ty	P/N	Q'ty	P/N	Q'ty		
	E81 002	1Set	F01 002	1Set	E71 002	1Set	F81 002	1Set	C01 005	1Set	F91 002	1Set	Main Body Ass'y	
1	E81 104	1	F01 108	1	E71 134	1	F81 104	1	C01 102	1	F91 104	1	Back Head	
2	C51 191	1	←	1	←	1	←	1	←	1	←	1	Charging Valve	
3	2851208	3	2851209	3	2851210	3	2851214	3	2856012	3	2851216	3	O-Ring	
4	E81 101	1	F01 101	1	E71 132	1	F81 101	1	C01 198	1	F91 101	1	Cylinder	
5	E81 109	1	F01 110	1	E71 138	1	F81 109	1	C91 125	1	F91 109	1	Seal Retainer	
6	2850010	3	←	3	←	3	2850014	3	2850016	3	←	3	O-Ring	
7	F01 129	3	←	3	←	3	F81 115	3	←	←	←	←	Plug	
7-1	←	←	←	←	←	←	←	←	C91 124	3	←	3	Socket Plug	
8	2835035	1	2835036	1	2835037	1	2835038	1	2835039	1	2835040	1	Gas Seal	
9	2811044	2	2811017	2	2811018	2	2811045	2	2811046	2	2811047	2	Step Seal	U-Packing
10	←	←	←	←	←	←	←	←	←	←	←	←	O-Ring	Not Use
11	2819063	1	2819061	1	2819059	1	←	←	←	←	←	←	Buffer Seal	
12	E81 105	1	F01 109	1	E71 102	1	F81 105	1	C01 114	1	F91 105	1	Piston	
13	2831057	1	2831058	1	2831013	1	2831063	1	2831022	1	2831017	1	Dust Seal	
14	2811055	1	2811056	1	2811010	1	2811060	1	2811031	1	2811009	1	U-Packing	
15	2819062	1	2819060	1	2819058	1	2833011	1	2819056	1	2833012	1	Buffer Seal	
16	2851018	2	←	2	←	2	←	2	←	2	←	2	O-Ring	
17	C91 120	2	←	2	←	2	←	2	←	2	←	2	Adapter	
18	2715002	2	←	2	←	2	←	2	←	2	←	2	Union Cap	
19	F01 104	1	←	1	E71 105	1	←	1	C01 127	1	F91 106	1	Valve	
20	F01 106	1	←	1	E71 140	1	←	1	C01 188	1	F91 108	1	Valve Plug	
21	2851030	1	←	1	2851033	1	←	1	2851204	1	←	1	O-Ring	
22	2851201	1	←	1	←	1	←	1	←	1	←	1	O-Ring	
23	F01 105	1	←	1	E71 139	1	←	1	C01 193	1	F91 107	1	Valve Sleeve	
24	E81 136	1	F01 152	1	E71 156	1	F81 132	1	C01 216	1	F91 142	1	Front Head	
25	2700411	1	←	1	←	1	←	1	←	1	←	1	Grease Nipple	
26	E81 139	1	F01 155	1	E71 158	1	F81 134	1	C01 219	1	F91 143	1	Rod Pin	
27	4300132	1	←	1	←	1	4300150	1	C91 151	1	←	1	Spring Pin	
28	4300141	2	4300143	2	←	2	←	2	C91 110	2	←	2	Spring Pin	
29	E81 140	2	F81 135	2	←	2	←	2	C01 131	2	F91 121	2	Stop Pin	
30	E81 138	1	F01 153	1	E71 157	1	F81 133	1	C01 217	1	F91 110	1	Ring Bush	
31	E81 137	1	F01 154	1	E71 159	1	F81 111	1	C01 218	1	F91 111	1	Thrust Bush	
32	E81 141	1	F01 156	1	E71 160	1	F81 136	1	C01 220	1	F91 144	1	Rod(Moil Point)	
33	E81 120	4	F01 115	4	E71 116	4	←	4	C01 144	4	F91 114	4	Washer	
34	E81 118	4	F01 114	4	E71 114	4	F81 112	4	C01 145	4	F91 112	4	Through Bolt	
35	E81 119	4	F01 116	4	E71 115	4	←	4	C01 143	4	F91 113	4	Hex Nut	
36	C01 162	1	←	1	←	1	←	1	←	1	←	1	Air Check Valve	
37	←	←	←	←	←	←	←	←	←	←	←	←	O-Ring	Not Use
38	F01 128	3	←	3	←	3	F81 114	3	←	←	←	←	Cover Plate	
39	←	←	←	←	←	←	←	←	2702221	1	←	1	Hollow Hex Plug	
40	←	←	←	←	←	←	←	←	←	←	←	←	←	Not Use
41	←	←	←	←	←	←	←	←	←	←	←	←	Heli Sert Coil	Not Use
42	←	←	←	←	←	←	←	←	←	←	←	←	Hex Head Plug	Not Use

HYDRAULIC BREAKER PARTS LIST

■ WHB45,50

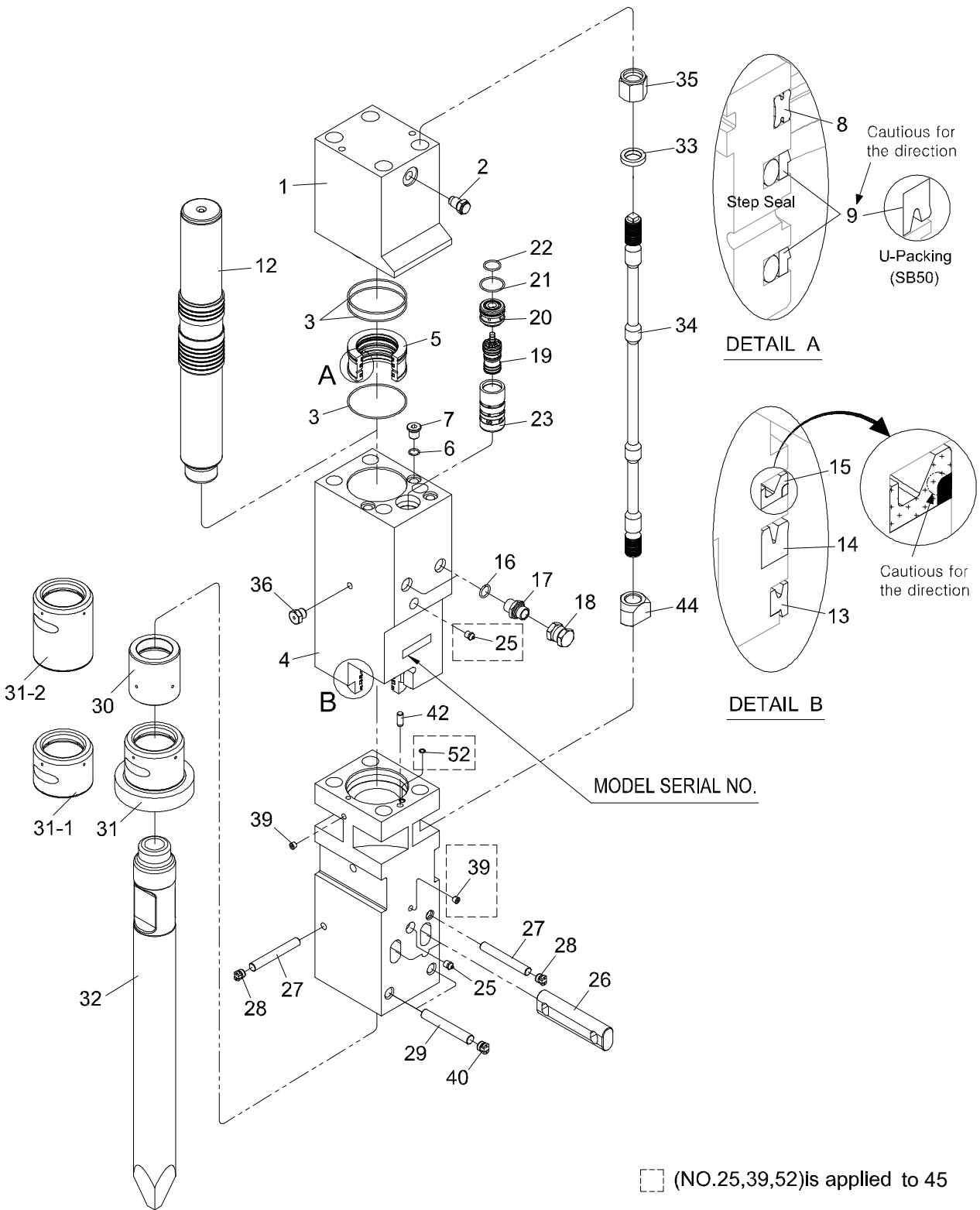

HYDRAULIC BREAKER PARTS LIST

■ MAIN BODY (WHB45,50) - (#~) is applied Serial Number)

NO	WHB45		WHB50		PARTS NAME	REMARK
	P/N	Q'ty	P/N	Q'ty		
1	D41 001	1Set	C11 003	1Set	Main Body Ass'y	
2	D41 110	1	C11 112	1	Back Head	
3	C51 191	1	←	1	Charging Valve	
4	2851219	3	2851223	3	O-Ring	
5	D41 106	1	C11 192	1	Cylinder	
6	D41 108	1	C11 119	1	Seal Retainer	
7	2850017	5	2850020	3	O-Ring	
8	D41 109	3	C11 120	3	Socket Plug	
9	2835041	1	2835042	1	Gas Seal	
10	2811048	2	2811067	2	Step Seal	U-Packing
11	-	-	2850017	2	O-Ring	Charging Valve
12	-	-	-	-	Buffer Seal	Not Use
13	D41 107	1	C11 194	1	Piston	
14	2831068	1	2831023	1	Dust Seal	
15	2811064	1	2811032	1	U-Packing	
16	2833001	1	2833015	1	Buffer Seal	
17	2851022	2	←	2	O-Ring	
18	2710311	2	←	2	Adapter	
19	2715003	2	←	2	Union Cap	
20	D41 113	1	C11 123	1	Valve	
21	D41 111	1	C11 184	1	Valve Plug	
22	2851205	1	2851051	1	O-Ring	
23	2851202	1	2851203	1	O-Ring	
24	D41 112	1	C11 183	1	Valve Sleeve	
25	D41 148	1	C11 193	1	Front Head	
26	2700411	2	2700403	1	Grease Nipple	
27	D41 147	2	C11 186	2	Rod Pin	
28	D41 119	2	C11 131	2	Stop Pin	
29	D81 151	2	←	2	Rubber Plug	
30	D41 118	2	C11 128	2	Front Head Pin	
31	D41 141	1	C11 182	1	Ring Bush	
31-1	D41 102	1	C11 127	1	Front Cover	
31-2	D41 142	1	C11 181	1	Front Cover	Side Silence
32	-	-	C11 266	1	Front Cover	TR-F
33	D41 101	1	C11 195	1	Rod(Moil Point)	
34	D41 115	4	C11 141	4	Washer	
35	D41 160	4	C11 220	4	Through Bolt	
36	D41 161	4	C11 221	4	Hex Nut	
37	C01 162	1	←	1	Air Check Valve	
38	-	-	-	-	O-Ring	Not Use
39	-	-	-	-	O-Ring	Not Use
40	2702221	2	←	1	Hollow Hex Plug	
41	C31 246	2	D81 150	2	Rubber Plug	
42	-	-	-	-	Snap Ring	Not Use
43	U81 278	1	←	1	Knock Pin	
44	-	-	-	-	Hex Head Plug	Not Use
45	D41 162	4	C11 222	4	Round Nut	
46	-	-	-	-	O-Ring	Not Use
47	-	-	-	-	Back-Up Ring	Not Use
48	-	-	-	-	Valve Adjuster	Not Use
49	-	-	-	-	Nut	Not Use
50	-	-	-	-	Socket Plug	Not Use
51	-	-	-	-	Square Ring	Not Use
52	-	-	-	-	Socket Plug	Not Use

