



ELECTRIC MINI DUMPER

User Manual

SAFETY AND OPERATION INSTRUCTIONS



IMPORTANT: Read safety rules and instructions carefully before operating equipment.

Table of Contents

PART I: General Safety Rules.....	2
PART II: Familiar with the Mini Dumper.....	6
PART III: Operating the Mini Dumper	7
PART IV: Maintaining the Mini Dumper	8
PART V: Parts List.....	9

Conventions used in this manual

WARNING

This indicates a hazardous situation, which, if not avoided, could result in death or serious injury.

CAUTION

This indicates a hazardous situation, which, if not avoided, could result in minor or moderate injury.

NOTICE

This information is important in proper using of your machine. Failure to follow this instruction could result in damage to your machine or property.

Additional Information and Potential Changes

We reserve the right to discontinue, change, and improve its products at any time without notice or obligation to the purchaser. The descriptions and specifications contained in this manual were in effect at printing. Equipment described within this manual may be optional. Some illustrations may not be applicable to your machine.

PART I: General Safety Rules

Improper installation and operation could cause personal injury, and/or equipment and property damage. Read and understand labels and the USER Manual before installing, operating, or making adjustments.

Safety Labels Found on Your Unit

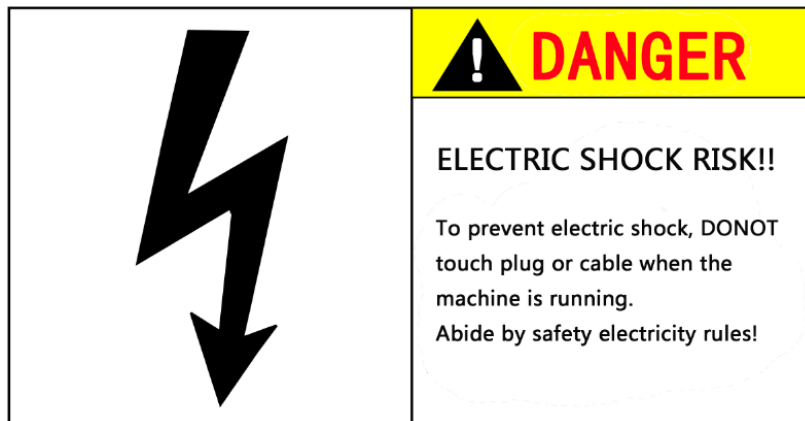

WARNING

Read this Safety & Operating Instructions manual before you use the Mini Dumper. Become familiar with the operation and service recommendations to ensure the best performance of your machine.

Propose

CAUTION

This machine is designed solely to transport goods and must not be used for any other purpose.

It should only be used by trained operators who are familiar with the content of this manual. It is potentially hazardous to fit or use any parts other than your dealer parts. The company disclaims all liability for the consequences of such use, which in addition voids the machine warranty.

Before using the Mini Dumper

NOTICE

- A. Operators must be fully trained before using this machine.
- B. User Manual is read and understood.
- C. Machine is positioned on level ground, all guards are fitted and in good condition.
- D. Shovel is in good condition and secure.
- E. All fasteners are checked for tightness.
- F. DO NOT use other types of battery charger or batteries.
- G. DO NOT Carry “passengers” on your Dumper.
- H. Exercise common sense at all times.

When using the Mini Dumper

NOTICE

- A. It is better to have a second trained operator within easy reach of the machine.
- B. Maintain strict discipline at all times and service machine at specified periods.
- C. DO NOT operate the machine whilst under the influence of alcohol or drugs.
- D. Check all nuts, bolts, and wheel studs weekly.
- E. Keep the dumper free of any accumulation of dirt, grease, oil or other flammable material.

Protecting Yourself and Those Around You

WARNING

This is a high-powered machine, with moving parts operating with high energy. You must operate the machine safely. Unsafe operation can create a number of hazards for you, as well as anyone else in the nearby area. Always take the following precautions when using this machine:

- A. Keep in mind that the operator or user is responsible for accidents or hazards occurring to other people, their property, and themselves.
- B. Avoid wearing loose clothing or jewelry, which can catch on moving parts.
- C. We recommend wearing gloves while using the Mini Dumper. Be sure your gloves fit properly and do not have loose cuffs or drawstrings.
- D. Wear shoes with non-slip treads when using your machine. If you have safety shoes, we recommend wearing them.

Safety for Children and Pets

WARNING

Tragic accidents can occur if the operator is not alert to the presence of children and pets. Children are often attracted to the machine and the activity. Never

assume that children will remain where you last saw them. Always follow these precautions:

- A. Keep children and pets at least 50 feet from the working area and ensure they are under the watchful care of a responsible adult.
- B. Be alert and turn the machine off if children or pets enter the work area.
- C. Never allow children to operate the machine.

General Safety

WARNING

Operating this machine safely is necessary to prevent or minimize the risk of injury. Unsafe operation can create a number of hazards for you. Always take the following precautions when operating:

- A. Your machine is a powerful tool, not a plaything. Exercise extreme caution at all times. The machine is designed to plow snow. Do not use it for any other purpose.
- B. Know how to stop the machine quickly.
- C. See manufacturer's instructions for proper operation and installation of accessories.
- D. Never, under any conditions, remove, bend, cut, fit, weld, or otherwise alter standard parts on the machine. This includes all shields and guards. Modifications to your machine could cause personal injuries and property damage and will invalidate your warranty.
- E. If the machine start to make an unusual noise or vibrate, shut down the motor, then inspect for damage. Vibration is generally a warning of trouble. Check damaged parts and clean, repair and/or replace as necessary.
- F. Never tamper with safety devices. Check their proper operation regularly.
- G. Never allow people who are unfamiliar with these instructions to use the machine. Allow only responsible individuals who are familiar with these rules of safe operation to use your machine.
- H. While using, don't hurry or take things for granted. When in doubt about the equipment or your surroundings stop the machine and take time to look things over.
- I. Never operate the machine when under the influence of alcohol, drugs, or medication.
- J. Use the machine only in daylight.
- K. Stay alert for hidden hazards or traffic.
- L. Keep all nuts and bolts tight and keep the equipment in good operating condition.
- M. Be safety conscious and dress appropriately when operating. Always wear substantial footwear and a hard hat in relevant areas.
- N. Exercise extreme caution with the controls when working on steep or

slippery surfaces. Especially, when people are near to the working area.

A Note to All Users

List of warnings and cautions cannot be all-inclusive. If situations occur that are not covered by this manual, the operator must apply common sense and operate this machine in a safe manner. Contact the dealers for assistance in your area.

PART II: Familiar with the Mini Dumper

It may be helpful to familiarize yourself with the controls and features of the Mini Dumper. If you have any question, please contact the dealers in your area.

TECHNICAL SPECIFICATIONS

Power	48V/20AH/1000W Electric
Load capacity	500kgs
Total Working time	3 Hours
Charging time	5-6hours
Power Capacity showing	Yes
Speed	0-5KM/H
Reverse Gear	YES
Front wheel	16*4.8-8
Rear wheel	11*4-4
Overall Height	849mm
Overall Length	1547mm
Width	839mm
Weight	200/228kgs

PART III: Operating the Mini Dumper

It may be helpful to better familiarize yourself with the features of your machine before beginning the steps outlined in this chapter.

WARNING

- A. Read and understand all instructions, safety precautions, and/or warnings listed in “PART I: General Safety Rules” before operating the machine. If any doubt or question arises about the correct or safe method of performing anything found in this manual, please contact the dealers in your area.
- B. Knowing the correct and incorrect methods of using the machine. Never using an incorrect or unsafe method.

Before Using:

1. Using the battery charger supplied to charge the batteries until the green light on the charger comes on.
2. Check the control cables, condition of wiring, tire pressure and all nuts/bolts.

Moving Forward:

1. Turn the key switch $\frac{1}{4}$ turn clockwise to “ON” position on the front panel.
2. Select “Forward” position on the toggle switch on the left handle.
3. Turn the key of the right handle on and can see the battery light on.
5. The speed of the dumper is controlled by the amount of throttle, which is on the right handlebar, is rotated anti-clockwise. The maximum speed that the dumper can reach is about 5KM/Hour.

Moving Backward:

1. Release the right handle to stop the Dumper.
2. Move the switch of the left handle to “Backward”.
3. Rotate the right handlebar to move the Dumper backward.

STOP:

Release the rotation of the right handlebar. The Dumper will slow down and stop. The key switch must be turned off and back on again to activate the dumper.

Dumping:

1. Stop the machine and disengage right handle rotation.
3. Turn the “dumping switch” clockwise and hold until dumping finished. Turn switch anti-clockwise to restore the dumper.

PART IV: Maintaining the Mini Dumper

Regular maintenance is the way to ensure the best performance and long life of your machine. Please refer to this manual for maintenance procedures.

WARNING

1. Before performing any maintenance procedure or inspection, stop the motor.
2. To prevent accidental movement of the machine, always turn the ON/OFF switch to OFF and disconnect the battery plug whenever the Mini Dumper is not in use. The control indicator light will turn off.
3. Disconnect the battery before removing or replacing any electrical components.

Lubrication

NOTICE

All Bearings of your machine are sealed units and should have sufficient lubricant to last the life of your machine with normal use.

Maintenance

Most problems are easy to fix. If you experience problems, contact the dealers in your area.

WARNING

Before performing any maintenance procedure or inspection, stop the motor.

PART V: Parts List

Ref.No.	Description	Ref.No.	Description
1	Bucket	32	Main frame
2	Handle cover	33	Ø4 cotter pin
3	Switch	41	Bucket rotate axle
4	Right handrail	44	M16 lock nut
8	Electric box	49	Rear axle mud guard
9	Push bar switch	56	16*6.5-8 wheel
10	Thermal overload	57	Rear axle assembly
11	Main switch	58	Rear axle mud guard
12	Brake handle	59	Rear axle controller
15	Left handrail	60	Ø19*Ø11*58 spacer
16	Battery	61	Rear axle fitting plate
17	Battery box bottom	66	6204 bearing
18	Battery box cover plate	67	Rear wheels brace
19	Battery cover	68	95*Ø21*Ø25 spacer
20	Charge point	69	Rear wheel frame
22	Bucket fitting plate	70	M16*95 screw
23	Log rod	71	Rear wheel
24	Right short rod	72	Right frame cover
25	23*Ø12*Ø20 Spacer	73	Left frame cover
26	Pusher rod	74	Battery box baffle
27	Left short rod	93	Bolt M6*110
28	17*Ø11*Ø15 Spacer	94	Nut M6
29	Shocking reduction	95	Lock nut M6
31	Rear wheel frame		

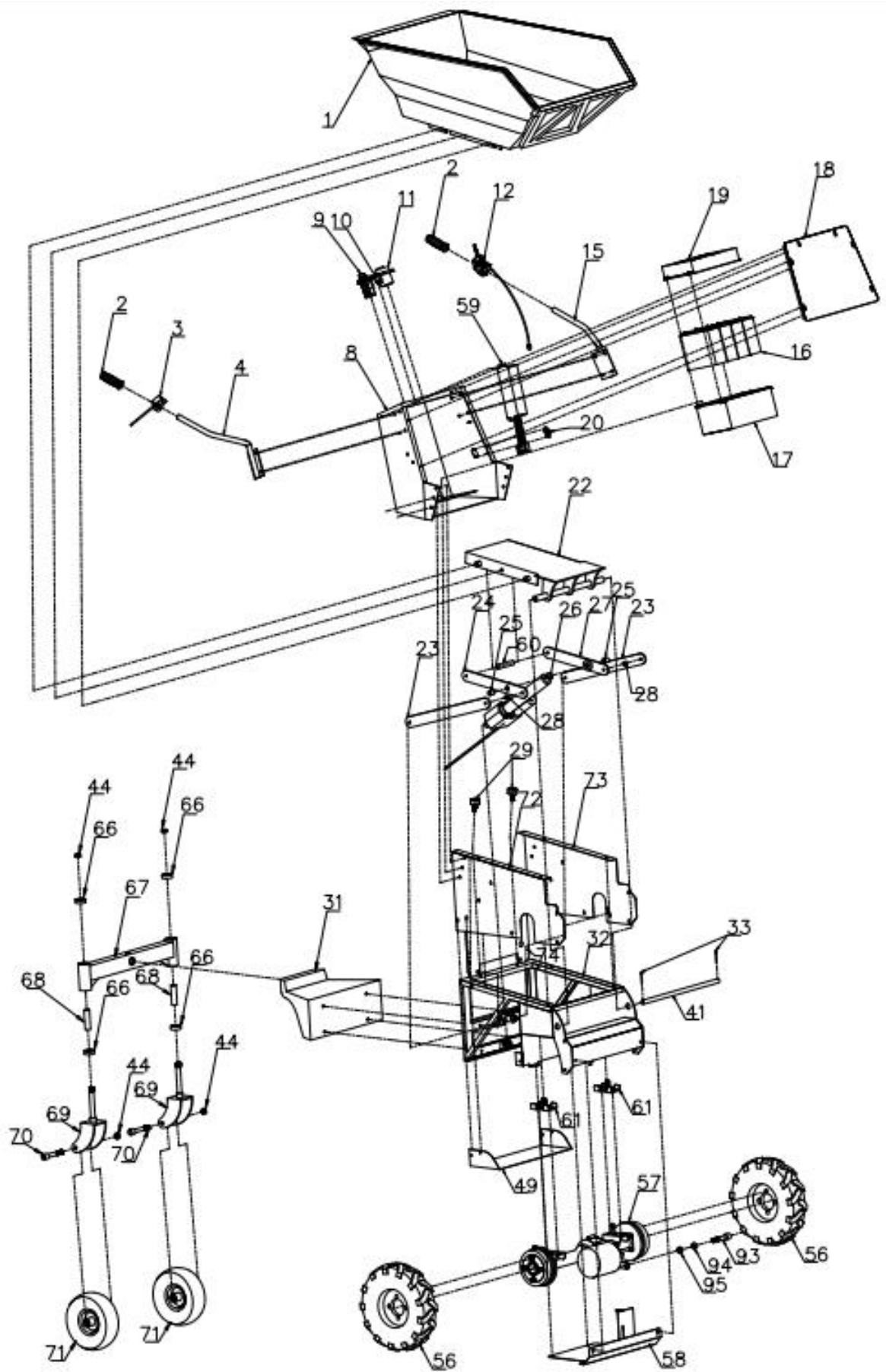

Wiring Diagram

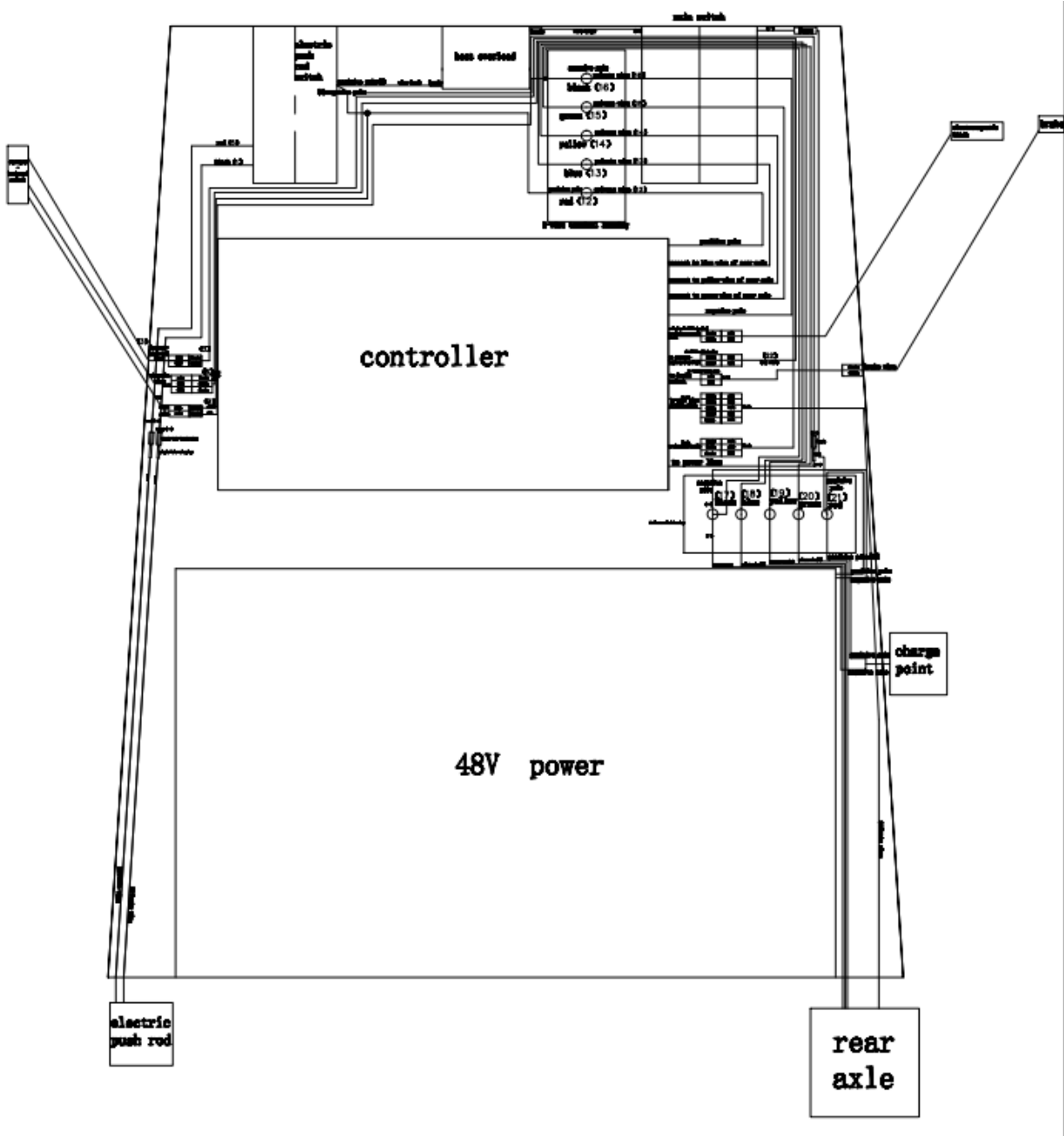

All right reserved, specifications are subject to change without prior notice.